

SM 3300



FROZEN ICE



Modular ice maker up to 1560 kg - Scale system

• Position n°



• Application fields

Hotel	●●●●●●●●●●	Fish market	●●●●●●●●●●
Restaurant	●●●●●●●●●●	Supermarket	●●●●●●●●●●
Fast food	●●●●●●●●●●	SPA	●●●●●●●●●●
Bar	●●●●●●●●●●	Medical	●●●●●●●●●●
Disco	●●●●●●●●●●	Industry	●●●●●●●●●●

• Features & Plus

- Subcooled flakes (from -5°C to -10°C)
- Low consumption (1 liter water / 1 kg ice) - aircooled vers.
- Electromechanical functioning
- External structure AISI 304 Scotch Brite
- Stainless steel frame
- Evaporator anticorodal alloy made, with rotating knife
- Air Cooling and Water Cooling systems
- Standard and special voltages
- 1 m³ = 430 kg of ice
- ABS plastic components, FDA approved
- Easy cleaning thanks to rounded surfaces
- Cleanable antiscaling filter
- Removable and cleanable air filter
- Conformity to RoHS directive
- Automatic water charge
- Model in Tropical Class + 43 °C

• Usable Bins

- BIN 1200DD
- DRB 1100
- DRB 2500

• Prod. 24h

Air temp.	Water temp.	Prod. 24h kg
10° C	10° C	1560
21° C	15° C	1500
32° C	21° C	1200

2 Years Warranty

subject to limitations

• Certifications available for this model



N.T.F. S.r.l. Nuove Tecnologie del Freddo

Via dell'Industria 10/B tel. +39 0331 436217
20020 Villa Cortese (MI), Italy fax +39 0331 436218

www.ntfice.it
info@ntfice.it



ntfice.it



SM 3300



FROZEN ICE



Modular ice maker up to 1560 kg - Scale system

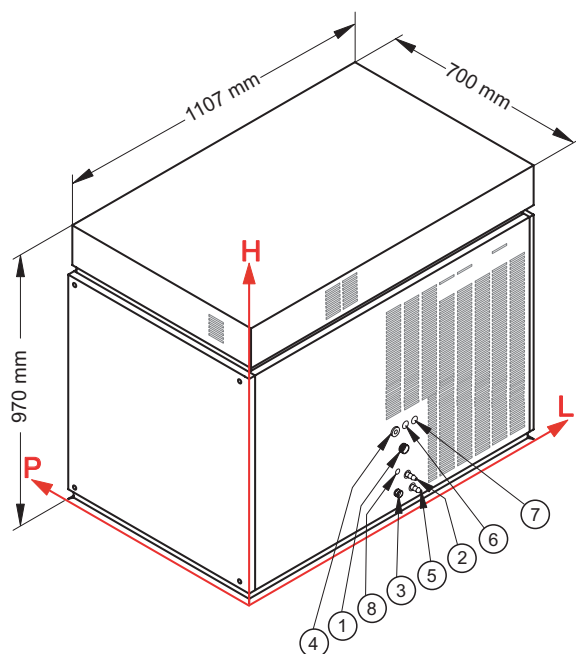

● Working conditions

- Location: Indoor

	Min	Max
Ambient temperature	+10° C	+43° C
Water temperature	+3° C	+32° C
Voltage	-10%	+10%
Water inlet pressure	1bar (14 psi)	6bar (84 psi)

● Technical information

Production in 24h	1500 kg
Cooling system	A - W
Refrigerant	R404A
Standard voltage	400-415 V ~ 3N 50 Hz
Electrical consumption	6000 W
Fuse	32 A
Water consumption	A: 1 l/kg W: 7 l/kg
Sizes (L-P-H mm)	1107 - 700 - 970
Sizes with pack (L-P-H mm)	1210 - 800 - 1185
Net weight	306 kg
Gross weight	342 kg
Finish	AISI 304 stainless steel, scotch brite

● Connections

All measures are referred to the rear bottom-left corner (L-H-Ø)

- ① Water inlet:
563 mm - 192 mm - 3/4"
- ② Condenser water inlet:
563 mm - 125 mm - 12 mm
- ③ Water outlet:
528 mm - 65 mm - 24 mm
- ④ Electrical connection:
532 mm - 262 mm
- ⑤ Condenser water outlet:
573 mm - 65 mm - 12mm
- ⑥ Remote connection:
574 mm - 262 mm
- ⑦ Connection to DRB 1100:
608 mm - 262 mm
- ⑧ Connection to saline solution dosing pump:
515 mm - 159 mm

② ⑤ Only for water cooling systems

All the technical information must be considered at the following conditions:



Ambient temperature
+21° C



Water temperature
+15° C



Electrical consumption
at +21° C
(standard voltage)

Models and specifications are subject to change without notice
Rev. 00 - Issued January 2017



N.T.F. S.r.l. Nuove Tecnologie del Freddo

Via dell'Industria 10/B tel. +39 0331 436217
20020 Villa Cortese (MI), Italy fax +39 0331 436218

www.ntfice.it
info@ntfice.it



ntfice.it

