

VISUAL LEVEL INDICATORS



LV...

The level indicators series is available for both static and mobile applications; the construction materials used make it possible to guarantee service with wide temperature variations and compatibility with all hydraulic fluids. Series LV... level indicators are available with fixing centre distance from 76 to 1000 mm.

LVK

This level indicator series is available with electric alarm and visual and electrical temperature switches, level indicators are available with fixing centre distance from 76 to 254 mm.

LC...

LC... series sight plugs allow visibility of the fluid contained in the reservoirs, showing the level and also any changes in transparency and emulsion.

These indicators are available in three configurations, with transparent plastic body and with black body, and an aluminium body version. Fixing to reservoirs with unthreaded holes or reduced thickness can be achieved using series LCC/T equipped with expansion kit.

Temperature

- LVA: from -25°C to $+100^{\circ}\text{C}$
- LVU: from -25°C to $+70^{\circ}\text{C}$
- LVU: from -25°C to $+100^{\circ}\text{C}$ (only with pyrex lens)
- LVK/LC...: from -20°C to $+80^{\circ}\text{C}$

Compatibility

LVA/LVK/LVU

- NBR seals and Cork Gasket, compatible with:
Mineral oils to ISO 2943 - aqueous emulsions
Synthetic fluids, glycol water.
- FPM seals, compatible with:
Synthetic fluids type HS-HFDR-HFDS-HFDU.

LC...

- Mineral oils to ISO 2943 - aqueous emulsions
Synthetic fluids, glycol water.

Series LVA

Dimensions

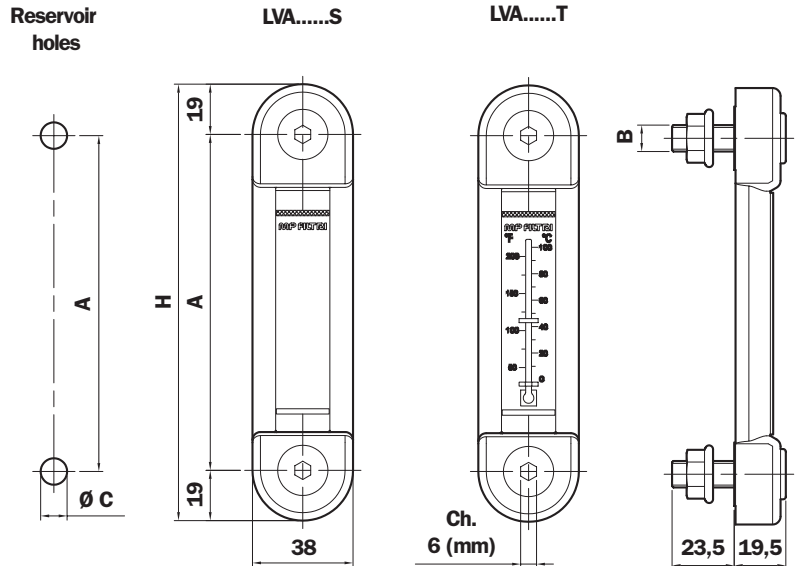
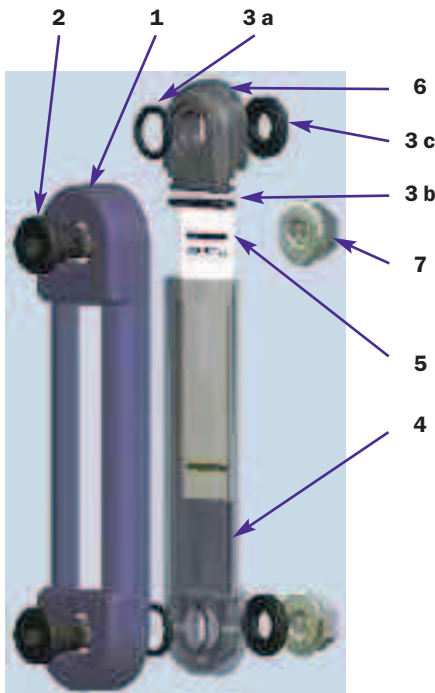

LVA (Materials)

- 1 - Cover: Polyamide
- 2 - Screws: Galvanised Steel
- 3 - Seals: NBR
FPM
- 4 - Lens: Polyamide
- 5 - Nameplate: Painted Aluminium
- 6 - Terminal cap: Nylon
- 7 - Nuts: Galvanised Steel

Weight

- LVA10: 0,13 Kg
- LVA20: 0,18 Kg
- LVA30: 0,23 Kg

Quantity per pack Number of Parts

LVA	10
------------	----

Size	A	H
LVA10	76	114
LVA20	127	165
LVA30	254	292

Screw tightening torque: 15Nm

Type	B	C
LVA.....M10	M10	10,5
LVA.....M12	M12	12,5
LVA.....U38	3/8" UNC	10
LVA.....U12	1/2" UNC	13,5

Ordering information

LVA20T.....S01

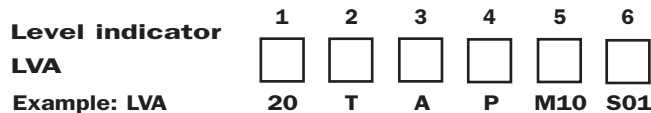

1 - Size

- 10
- 20
- 30

2 - Accessories

- S Without thermometer
- T With thermometer

3 - Seal

- A NBR
- V FPM

4 - Cover

- P Cover Polyamide

5 - Connection

- M10 Screws M10
- M12 Screws M12
- U38 Screws 3/8" UNC
- U12 Screws 1/2" UNC

6 - Options

- S01 With nuts - Tag MP Filtri
- S02 Without nuts - Tag MP Filtri

Series LVK

Description

Visual/electric level indicator with temperature controls for both static and mobile applications.

Completely transparent, it provides a view of the fluid over the entire length, both from the front and on both sides.

The quality and thickness, 4 millimetres, of the construction material provides the utmost dependability and mechanical strength without any need for additional protection.

LVK (Materials)

1 - Body: Polyamide

2 - Screws: Nickel Plated Brass (Standard)
AISI 316 (Option)

3 - Seals: NBR (Standard)
FPM (Option)

4 - Float: Polyamide

5 - Sensor thermometer: Screw + thermometer

Temperatures: from -20 °C to +80 °C

Screw tightening torque: 10Nm

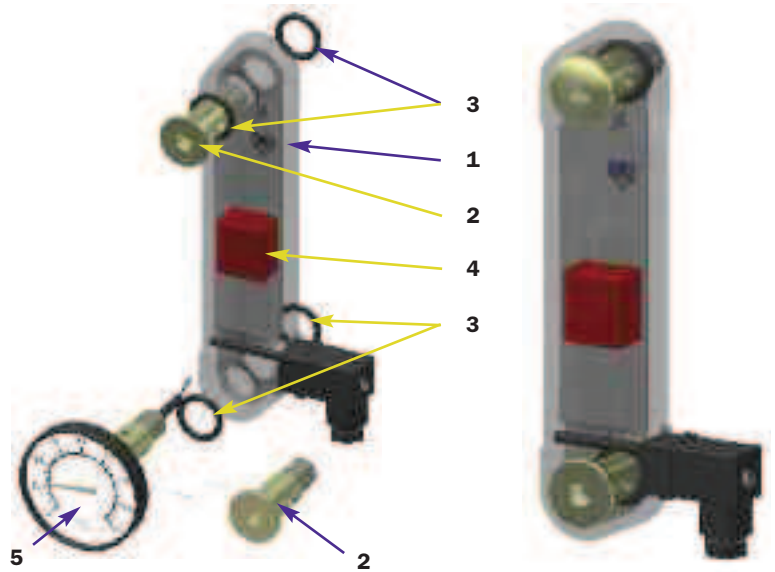

Compatibility

- NBR seals, compatible with:
Mineral oils to ISO 2943 - aqueous emulsions
Synthetic fluids, glycol water.
- FPM seals, compatible with:
Synthetic fluids type HS-HFDR-HFDS-HFDU.

Dimensions

Reservoir holes

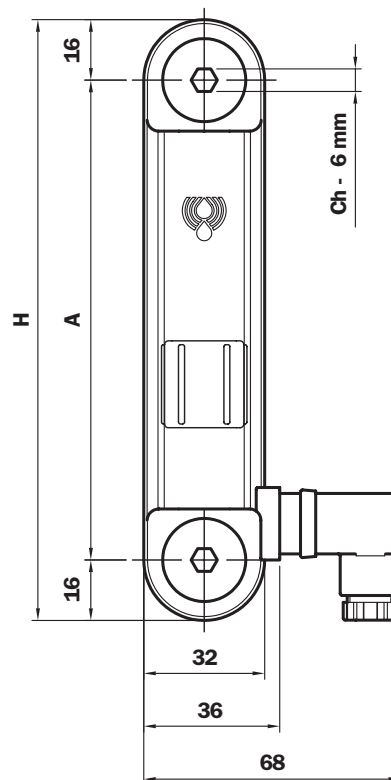
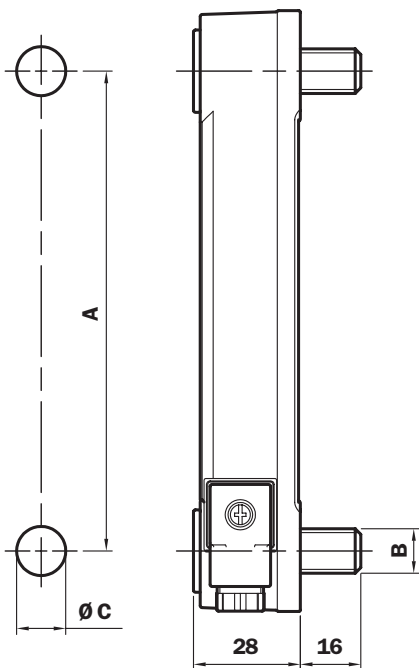

Sensor thermometer

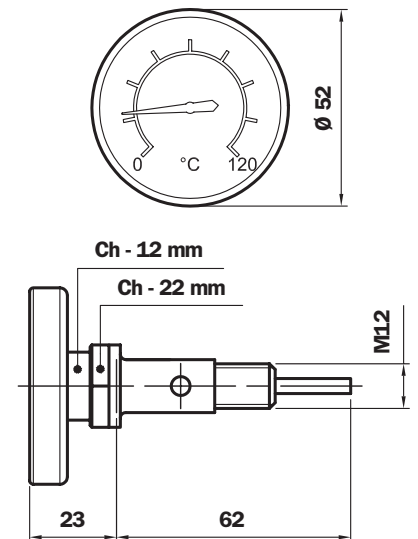

Weight

LVK10: 0,14 Kg

LVK20: 0,17 Kg

LVK30: 0,25 Kg

Size	A	H	Type	B	C
LVK10	76	108	LVK.....M10	M10	10,5
LVK20	127	159	LVK.....M12	M12	12,5
LVK30	254	286			

Weight (Kg)

TV12	Weight (Kg)	Kit Sensor thermometer + Screw M12
TV12	0,100	Kit Sensor thermometer + Screw M12

Combination of available electrical contacts

Electrical contact with no liquid

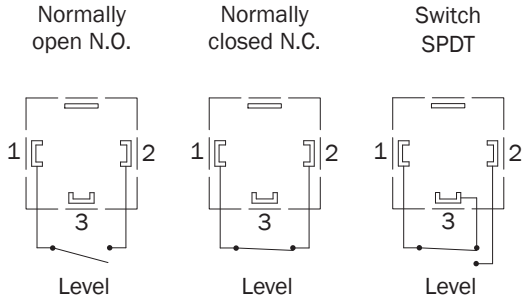

Electrical contact with no liquid + thermostat

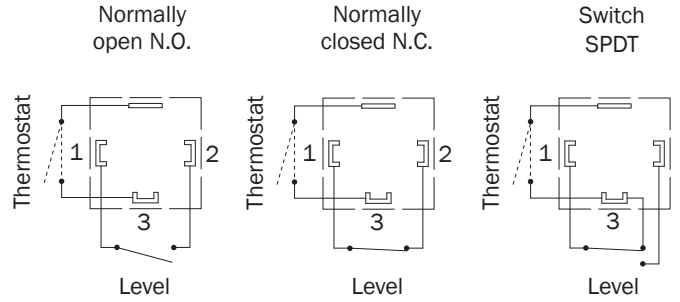

Available thermostated contact N.C. - N.O. in both setups

Electrical contact with no liquid + PT 100

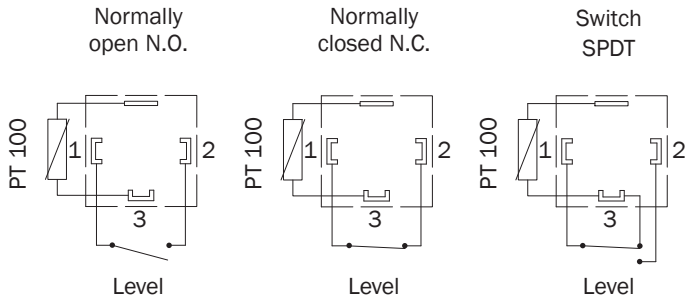

Dimension screw + electrical contact + thermostated or PT 100

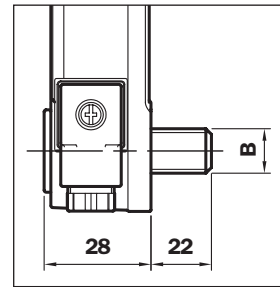

Thermostat electrical specifications

Voltage: 250 V Switchable
 Frequency: 50 Hz
 Load values: 4.0 A. $\cos \varphi$ 0.6 (IMOT)
 6,3 A. $\cos \varphi$ 1 (IN)
 Max load: 10 A. $\cos \varphi$ 1
 Switching temperature: 50°C - 60°C - 70°C
 Tolerances: $\pm 5^\circ\text{C}$

Electrical specifications

Contact with no liquid

	N.O. N.C.	Switch
D.C. Switchable Power	40 W	20 W
D.C. current intensity - A.C.	40 V.A.	-
Switchable voltage.	2 A	1 A
Voltage switchable	230 V	150 V

Protection degree: IP65

Ordering information

Level indicator

LVK

Example: LVK

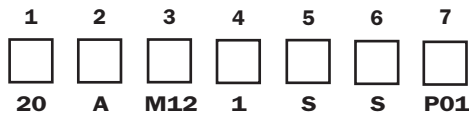

1 - Size



2 - Seal



3 - Connection

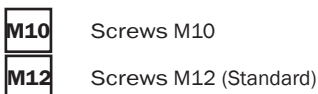

4 - Electrical contacts with no liquid

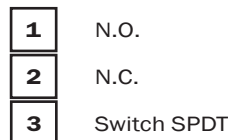

5 - Style

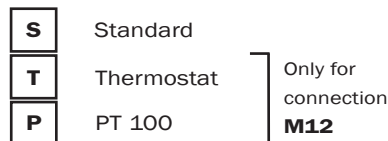

6 - Thermostat

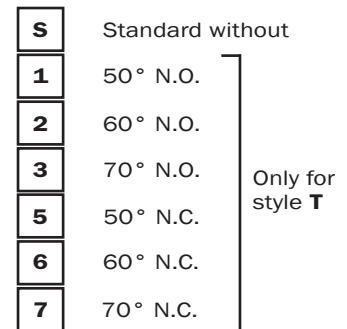

8 - Options



Accessories/Options*

TV12	Kit w/ Sensor thermometer Screw M12	M12 X	Kit w/ Screws M12 stainless steel AISI 316
M10 X	Kit w/ Screws M10 stainless steel AISI 316	02050432	Kit w/ FPM seals

* All the accessories are supplied separately from code LVK

Series LVU

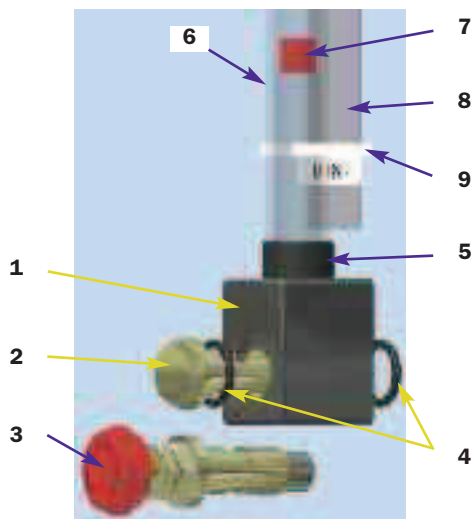

LVU (Materials)

- 1 - Head: Nylon
- 2 - Connection G 3/8": Nickel Plated Brass
- 3 - G 3/8" valve: Steel
- 4 - Seal: NBR
- 5 - Pipe Seal: NBR
- 6 - Pipe: Acrylic
Pyrex
- 7 - Float: Nylon
- 8 - Protection: Aluminium
- 9 - Clamps MIN - MAX: Nylon

Weight	Vesion U	Vesion S
LVU 0500	0,780 kg	0,580 kg
LVU 1000	1,150 kg	0,790 kg
LVU 1500	1,550 kg	1,100 kg
LVU 2000	1,950 kg	1,400 kg

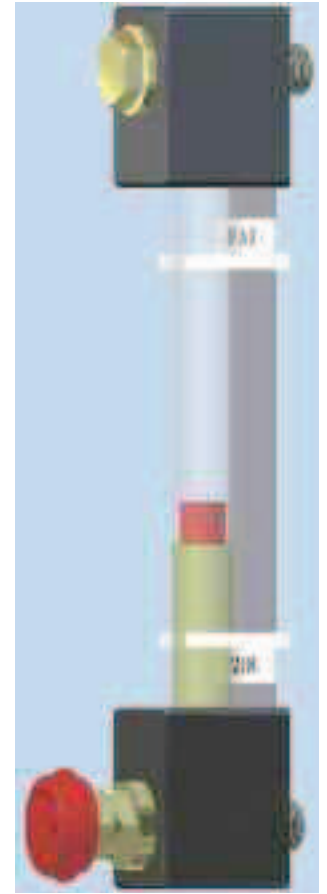

Open the valve completely.

Allows the oil to flow from the reservoir to the level tube.

ATTENTION - The intermediate valve opening or closing position allows the oil to flow from the reservoir to the exterior.



Close the valve fully.

Stops the oil flow from the reservoir to the level tube.

Allows the oil to be discharged from the level tube to an external container.

Dimensions

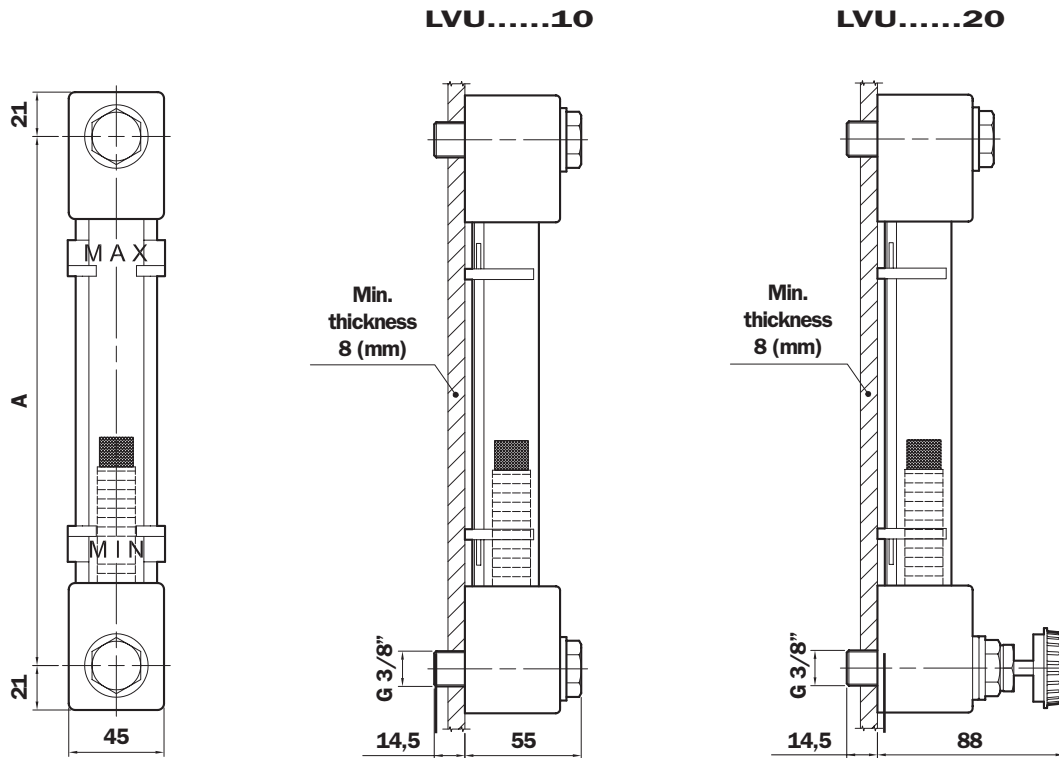

Spare parts LVU

Item.	Description	Q.ty	LVU
1	Seals kit	1	02050130
4	O-Ring	4	OR 4181 Ø 20,22 x 3,53
2	Fixing element kit series 10	1	02049014
2	G 3/8" connection	2	
3	Fixing element kit series 20	1	02049015
2	G 3/8" connection	1	
3	G 3/8" bibcock	1	

Size	A (mm)
0500	500
1000	1000
1500	1500
2000	2000

Ordering information

Level indicator
LVU
Example: LVU 1 2 3 4 5

0500 **U** **A** **10** **P01**

1 - Size

0500	Dimension "A" in mm
1000	Dimension "A" in mm
1500	Dimension "A" in mm
2000	Max. dimension "A" in mm
xxxx	Dimension "A" in mm (on request)

2 - Variants

S	Standard
U	"U" protection
P	"U" protection + Pyrex lens (max size 1500)

3 - Seal

A	NBR
----------	-----

4 - Connection

10	2 G 3/8" connections
20	1 G 3/8" connection + 1 valve

5 - Options

P01	MP Filtri standard
------------	--------------------

Series LCP***N

Dimensions



Standard view

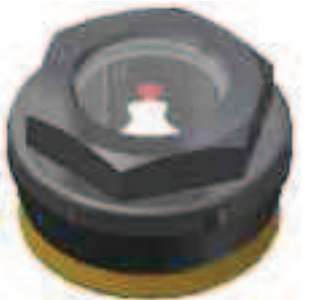

With view contrast and Expansion kit

LCP***N***S

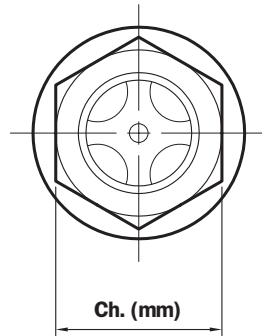

LCP***N***K

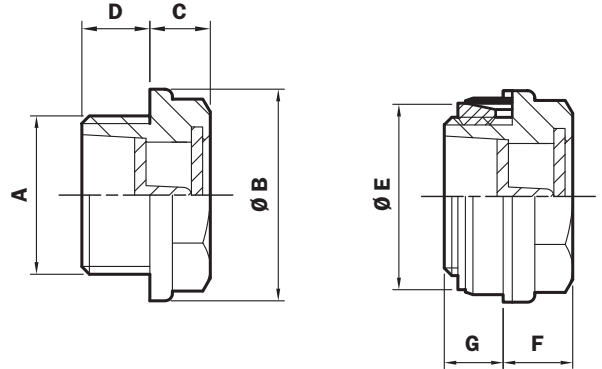

Size	A	Ø B	C	Ch. (mm)	D	Ø E	F	G
G13	G 1/4"	20	7	17	9	-	-	-
G16	G 3/8"	22	8	18	9	19,5	9,2	7,8
G20	G 1/2"	28	8	22	9	25,5	9,2	7,8
G26	G 3/4"	35	9	27	10	29,5	10,5	8,5
G33	G 1"	42	11,5	34	12,5	39	13	11
G42	G 1 1/4"	52	12	42	13	49	13,5	11,5
G48	G 1 1/2"	58	14	47	13	54	15,5	11,5
G60	G 2"	74	14	64	20	-	-	-

LCP***N***** (Materials)

- 1 - Body: Nylon
- 2 - Lens: Thermoplastic
- 3 - Contrast screen: Nylon
- 4 - Seals: NBR
Inorganic fibre
- 5 - Expansion kit: Brass - NBR

Quantity per pack Number of Parts

LCP/N 25

N.B. Recommended tightening torque 10 Nm.

Ø hole for Expansion kit

Size	Diameter
G16	Ø 20
G20	Ø 26
G26	Ø 30
G33	Ø 40
G42	Ø 50
G48	Ø 55

Spare parts

Size	Expansion Kit
-	-
G16	2026020
G20	2026021
G26	2026019
G33	2026023
G42	2026025
G48	2026026
-	-

Ordering information

Level indicator

LCP***N

Example: LCP

1	2	3	4	5	6
□	□	□	□	□	□
G20	N	C	A	K	P01

1 - Size

G13	G 1/4"
G16	G 3/8"
G20	G 1/2"
G26	G 3/4"
G33	G 1"
G42	G 1 1/4"
G48	G 1 1/2"
G60	G 2"

2 - Material

N Black nylon

3 - Accessories

S Standard view

C Baffle (for except G13)

4 - Seal

A NBR (only K)

B Inorganic fibre

5 - Expansion kit

S Without

K Expansion kit (for except G13)

6 - Options

P01 MP Filtri standard

Series LCP***T

Dimensions

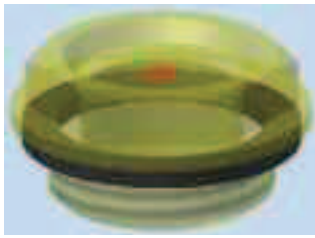

LCP***T**

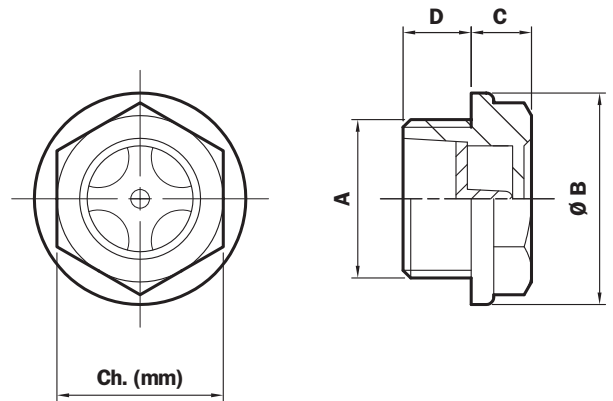

LCP***T** (Materials)

- 1 - Body: Polyamide
- 2 - Contrast screen: Nylon
- 3 - Seal: NBR

Quantity per pack Number of Parts

LCP/T 25

Size	A	Ø B	C	Ch. (mm)	D
G13	G 1/4"	19	4,5	15	7
G16	G 3/8"	21,7	5	17	7,5
G20	G 1/2"	27	5,5	21	8
G26	G 3/4"	32,8	6	26	9
G33	G 1"	39,8	6,5	32	10
G42	G 1 1/4"	52	12	42	13

N.B. Seals thickness 2 mm.
Recommended tightening torque 10 Nm.

Ordering information

Level indicator

LCP***T

Example: LCP

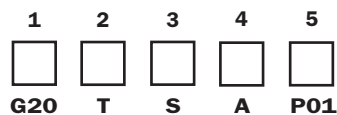

1 - Size

G13	G 1/4"
G16	G 3/8"
G20	G 1/2"
G26	G 3/4"
G33	G 1"
G42	G 1 1/4"

3 - Accessories

S	Without baffie
C	Baffie (G26-G33-G42 only)

4 - Seal

A	Fibre inorganique
---	-------------------

5 - Options

P01	MP Filtri standard
-----	--------------------

2 - Material

T	Polyamide
---	-----------

Series LCC***N

Dimensions

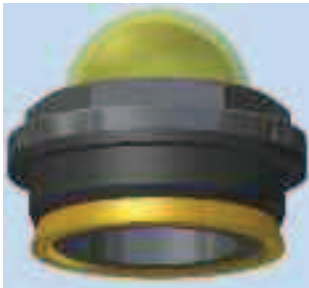
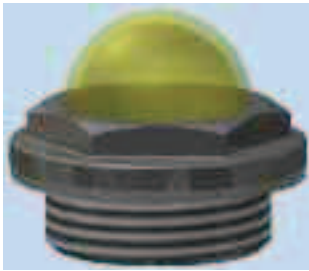

LCC***N***S

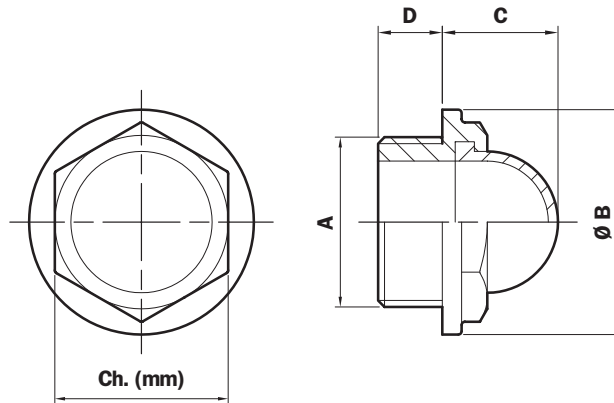

LCC***N***K

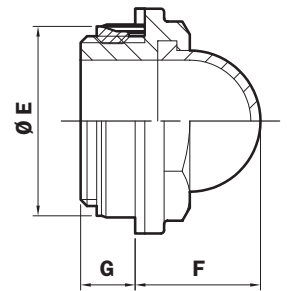

LCC***N***** (Materials)

- 1 - Body: Nylon
- 2 - Lens: Polyamide
- 3 - Contrast screen: Nylon
- 4 - Seals: NBR
Inorganic fibre
- 5 - Expansion kit: Brass - NBR

Quantity per pack Number of Parts

LCC/N 25

Size	A	Ø B	C	Ch. (mm)	D	Ø E	F	G
G20	G 1/2"	28	15,5	22	9,5	25,5	16,5	8,3
G26	G 3/4"	35	18	27	10	29,5	19,5	8,5
G33	G 1"	42	22	34	12	39	23,5	10,5
G42	G 1 1/4"	52	28	44	13	49	29,5	11,5
G48	G 1 1/2"	58	31	50	13,5	54	32,5	12
G60	G 2"	74	37	64	20	-	-	-

N.B. Seals thickness 2 mm.
Recommended tightening torque 10 Nm.

Ø hole for Expansion kit

Size	Diamètre
G20	Ø 26
G26	Ø 30
G33	Ø 40
G42	Ø 50
G48	Ø 55

Spare parts

Size	Expansion Kit
G20	G20
G26	G26
G33	G33
G42	G42
G48	G48
-	-

Ordering information

Level indicator

LCC***N

Example: LCC

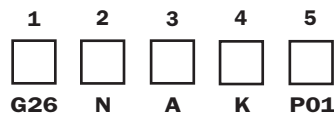

1 - Size

G20	G 1/2"
G26	G 3/4"
G33	G 1"
G42	G 1 1/4"
G48	G 1 1/2"
G60	G 2"

2 - Material

N Black nylon

3 - Seal

A NBR (K only)

B Inorganic fibre

4 - Expansion kit

S Without

K Expansion kit

5 - Options

P01 MP Filtri standard

Series LCC***T

Dimensions



LCC***T**

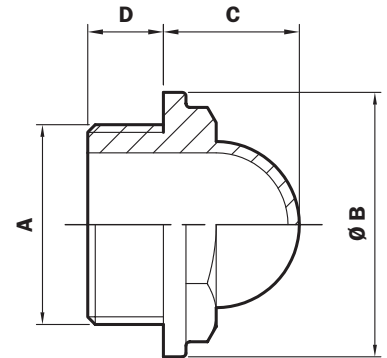
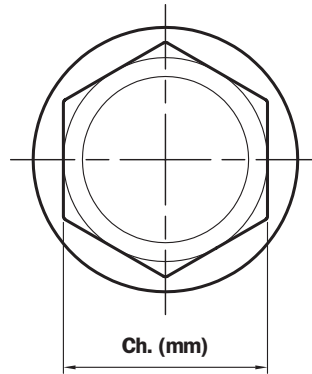

LCC*T** (Materials)**

1 - Body: Polyamide

2 - Seal: NBR

Quantity per pack

Number of Parts

LCC/T 25

Size	A	Ø B	C	Ch. (mm)	D
G13	G 1/4"	19	10,5	15	7
G16	G 3/8"	21,7	12	17	7,5
G20	G 1/2"	27	14,5	21	8
G26	G 3/4"	32,8	17	26	9
G33	G 1"	39,8	20,5	32	10

N.B. Seals thickness 2 mm.
Recommended tightening torque 10 Nm.

Ordering information

Level indicator

LCC***T

Example: LCC

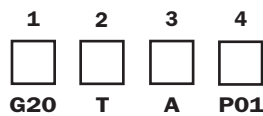

1 - Size

- G13 G 1/4"
- G16 G 3/8"
- G20 G 1/2"
- G26 G 3/4"
- G33 G 1"

3 - Seal

- A NBR

4 - Options

- P01 MP Filtri standard

2 - Material

- T Polyamide

