

OMIT

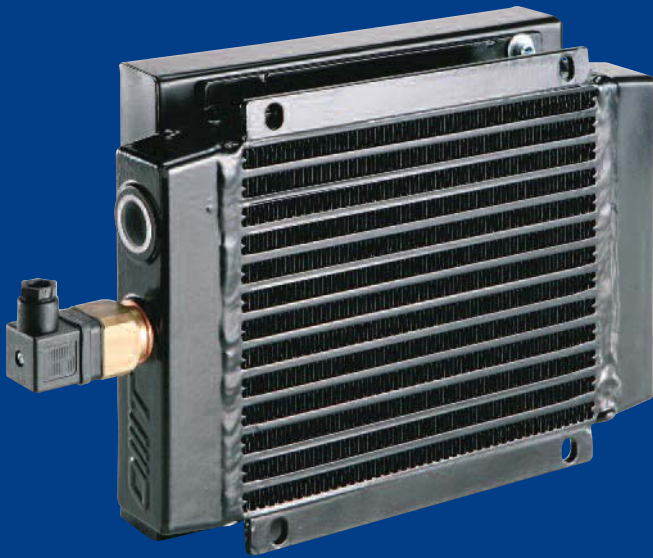

SERIE **ST** SERIES
Scambiatori di calore
Heat exchangers

Con il fine di migliorare costantemente la qualità dei nostri prodotti, ci riserviamo il diritto di modificarne in qualsiasi momento le caratteristiche senza preavviso.
È responsabilità della spettabile clientela la costante verifica dei dati contenuti nei cataloghi.
Questo catalogo annulla e sostituisce i precedenti.

In order to constantly improve our products quality, we take the right to make changes to the catalogues at any time without notice.
Customers have the responsibility to continuously check all the information in the catalogues.
This catalogue cancels and replaces the previous ones.

SCAMBIATORI DI CALORE SERIE "ST" HEAT EXCHANGERS SERIES "ST"



Gli scambiatori ARIA-OLIO della OMT, nascono per essere installati sulle linee di ritorno dei circuiti oleodinamici.

La speciale conformazione del pacco radiante, realizzato in lega di alluminio che ne esalta le qualità di conducibilità ed il processo di saldobrasatura dei turbinatori e dei condotti, hanno permesso di ottenere un elevato coefficiente di scambio termico e una buona resistenza alla pressione, qualità ottenuta tramite l'utilizzo di materiali altamente qualificati.

OMT air/oil heat exchangers have been designed to be used on the return line of the hydraulic systems.

The special structure of the cooler element in aluminium increases the conductivity quality, and the brase welding process of the conduits allows a high thermic exchange and a good resistance to pressure, obtained by using qualified materials.

CARATTERISTICHE TECNICHE

Specifiche pacco radiante

Materiale	Alluminio
Pressione di esercizio	25 bar
Pressione di collaudo	35 bar
Temperatura max d'esercizio	120°C

Compatibilità con i fluidi

Oli minerali, hl, hlp, emulsioni acqua-olio.

Installazione

È consigliabile installare in parallelo allo scambiatore una valvola di By-pass, per proteggerlo durante la fase di avviamento.

Inoltre assicurarsi di non interporre ostacoli alla portata dell'aria.

Manutenzione

Pulizia lato olio

Lo sporco potrà essere eliminato con il flussaggio di un prodotto detergente o sgrassante compatibile con l'alluminio. Alla fine di tale operazione bisognerà ricorrere all'aria compressa per eliminare i residui che restano all'interno.

Pulizia lato aria

La pulizia dovrà essere effettuata mediante aria compressa o acqua.

Durante tale operazione bisognerà prestare particolare attenzione alla direzione del getto per non rovinare le alette.

Se lo sporco è causato da olio o da grasso, la pulizia potrà essere effettuata con un getto di vapore o di acqua calda.

Durante tali operazioni il motore elettrico dovrà essere scollegato e adeguatamente protetto.

TECHNICAL FEATURES

Radiating mass data

Material	Aluminium
Nominal pressure	25 bar
Test pressure	35 bar
Max temperature	120°C

Fluid compatibility

Mineral oils, hl, hlp, water-oil emulsion.

Installation

We recommend to install a by-pass valve in parallel to the heat exchanger, for its protection during the starting up.

Make sure there is no obstacle to the air flow.

Maintenance

Oil side cleaning

Flushing with a detergent or a degreasing product compatible with aluminium, eliminates the dirt.

To remove the residuals, use compressed air.

Air side cleaning

It can be done by using compressed air or water and paying attention to the jet direction for not spoiling the vanes.

If oil or grease has to be removed, clean with a jet of steam or hot water.

Make sure that the electric motor is disconnected and properly protected.

MATERIALI UTILIZZATI

Ventola	Plastica rinforzata
Convogliatore	Lamiera
Griglia di protezione	Plastica rinforzata

MATERIALS

Fan	Hard plastic
Fan case	Iron sheet
Fan protection	Hard plastic

Scambiatori di calore serie "ST" aria-olio

Air-oil heat exchangers series "ST"



Di seguito sono riportati tre differenti tipi di scambiatori:

- serie "ST" standard
- serie "ST2" con doppio passaggio per portate ridotte, ma con maggiore potenzialità di scambio termico
- serie "SDT" per portate elevate.

Sull'asse delle ascisse viene indicata la portata d'olio che attraversa lo scambiatore, espressa in (lt/min), mentre sulle ordinate è indicato il rendimento di dissipazione per ogni grado centigrado, espresso in (kcal/h °C).

Il calore specifico di dissipazione (h) è dato dal rapporto tra la potenzialità termica (Q) dello scambiatore e la differenza di temperatura tra l'olio in entrata e la temperatura ambiente (T°olio-T°aria), con la seguente formula:

$$\eta = \frac{Q \text{ (kcal/h)}}{T^{\circ}\text{olio} - T^{\circ}\text{aria} \text{ (}^{\circ}\text{C)}}$$

Supponendo che lo scambiatore possa dissipare 3000 (kcal/h) e si abbia una differenza di temperatura (T°olio-T°aria) = 30 (°C):

$$\eta = \frac{3000 \text{ (kcal/h)}}{30 \text{ (}^{\circ}\text{C)}} = 100 \text{ (kcal/h }^{\circ}\text{C)}$$

Nel caso in cui non sia nota la potenzialità termica (Q) dello scambiatore è possibile calcolarla empiricamente con la seguente formula:

$$Q = 0,40 \cdot V \cdot \Delta t_o$$

Dove:

V = portata olio in (lt/h)

Δto = differenza temp. tra olio in entrata e in uscita

0,40 è un valore approssimato o utilizzabile per olio idraulico (nel caso non se ne conoscano il peso specifico e il calore specifico).

$$0,40 \text{ (kcal/lt }^{\circ}\text{C)} = c \cdot \gamma$$

dove: C = calore specifico (kcal/kg °C) Y = peso specifico (kg/dm ³)
--

Supponendo di avere una portata di 6000 (lt/h) e una differenza di temperatura tra olio in ingresso e olio in uscita (Δto) di 8 (°C) la potenzialità termica dello scambiatore è:

$$Q = 0,40 \cdot 6000 \cdot 8 = 19200 \text{ kcal/h}$$

Here you can find three different series of exchangers:

- series "ST" standard
- series "ST2" with double passage for reduced flows, but with bigger power of heat exchange
- series "SDT" for high flows.

On the abscissas you can find the oil flow going through the exchanger, expressed in (lt/min), while on the ordinates you can find the dissipation performance for each centigrade degree, expressed in (kcal/h °C).

The specific dissipation heat (h) is the result of the ratio between thermic power (Q) of the exchanger and the difference of the temperature between oil input and the ambient temperature (oil T°- air T°), using the following formula:

$$\eta = \frac{Q \text{ (kcal/h)}}{\text{oil T}^{\circ} - \text{air T}^{\circ} \text{ (}^{\circ}\text{C)}}$$

Supposing the exchanger can dissipate 3000 (kcal/h) and you have a temperature difference (oil T°- air T°) = 30 (°C):

$$\eta = \frac{3000 \text{ (kcal/h)}}{30 \text{ (}^{\circ}\text{C)}} = 100 \text{ (kcal/h }^{\circ}\text{C)}$$

When the thermic power (Q) of the exchanger is unknown, it is possible to calculate it empirically using the following formula:

$$Q = 0,40 \cdot V \cdot \Delta t_o$$

Where:

V = oil flow in (lt/h)

Δto = temperature difference between oil in and out

0,40 is an approximate value or it can be used for hydraulic oil (when specific weight and specific heat are unknown).

$$0,40 \text{ (kcal/lt }^{\circ}\text{C)} = c \cdot \gamma$$

where: C = specific heat (kcal/kg °C) Y = specific weight (kg/dm ³)

Supposing the flow is 6000 (lt/h) and the difference between oil in and out (Δto) is 8 (°C) the thermic power of the exchanger is:

$$Q = 0,40 \cdot 6000 \cdot 8 = 19200 \text{ kcal/h}$$

Scambiatori di calore serie "ST50" aria-olio Air-oil heat exchangers series "ST50"



CARATTERISTICHE TECNICHE DEL GRUPPO DI VENTILAZIONE TECHNICAL FEATURES

Tipologia Type	Frequenza Frequency Hz	Tensione Voltage V	Giri/min RPM N.°	Potenza Power kW	Ø ventola Ø FAN (mm)	dB (A)	Q air (m³/h)	Cap. (lt)	Peso Weight (kg)	IP
12	DC	12	3100	0.1	190	68	1300	0.48	6.5	67
24	DC	24	3000	0.1	190	68	1300	0.48	6.5	67

Portata olio consigliata da 10 a 80 (lt/min)
Suggested oil flow from 10 to 80 (lt/min)

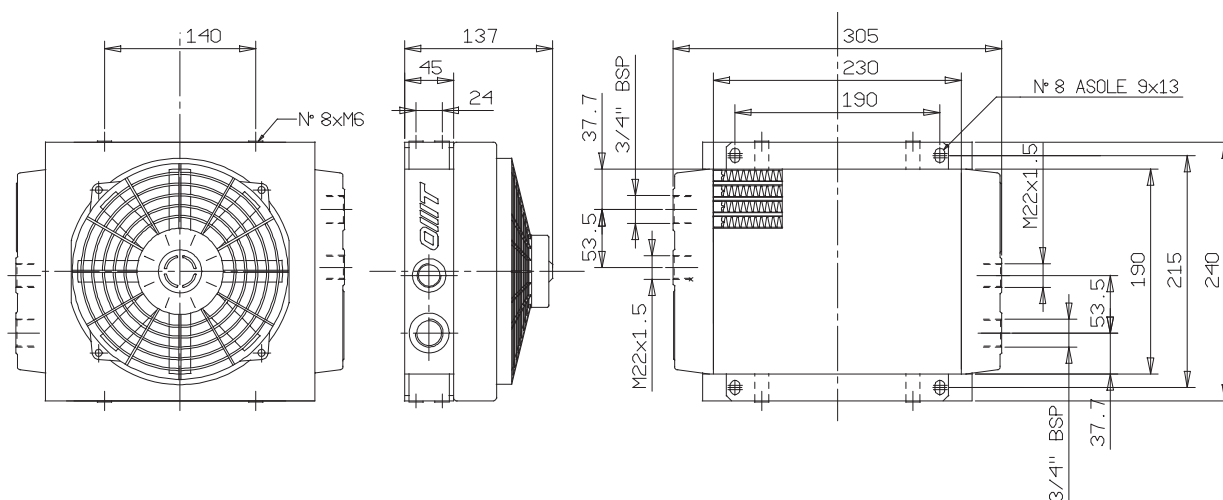

COEFFICIENTE DI CORREZIONE CORRECTION FACTOR

CST	10	15	20	32	40	50	60	80	100	200
F	0.51	0.66	0.76	1	1.22	1.4	1.6	1.9	2.1	3.4

DIAGRAMMA DI RENDIMENTO PERFORMANCE DIAGRAM



DIAGRAMMA PERDITE DI CARICO (32 cst) PRESSURE DROP DIAGRAM (32 cst)



Le dimensioni di ingombro e le caratteristiche tecniche non sono impegnative
Over-all dimensions and technical characteristic are not binding

Scambiatori di calore serie "ST60" aria-olio Air-oil heat exchangers series "ST60"

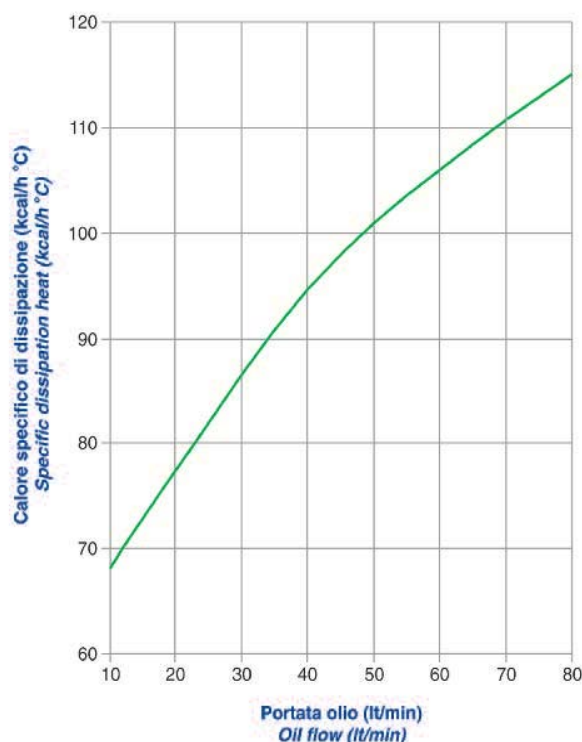
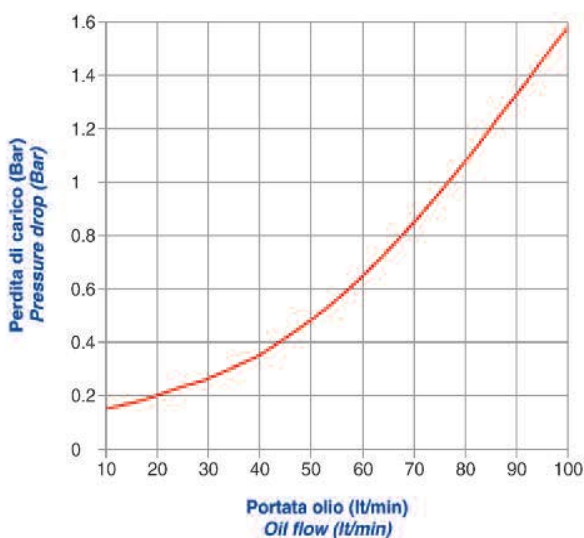

CARATTERISTICHE TECNICHE DEL GRUPPO DI VENTILAZIONE TECHNICAL FEATURES

Tipologia Type	Frequenza Frequency Hz	Tensione Voltage V	Giri/min RPM N.°	Potenza Power kW	Ø ventola Ø FAN (mm)	dB (A)	Q air (m³/h)	Cap. (lt)	Peso Weight (kg)	IP
12	DC	12	3000	0.175	305	79	2100	1.5	7.5	67
24	DC	24	3000	0.175	305	82	2200	1.5	7.5	67

Portata olio consigliata da 20 a 130 (lt/min)
Suggested oil flow from 20 to 130 (lt/min)

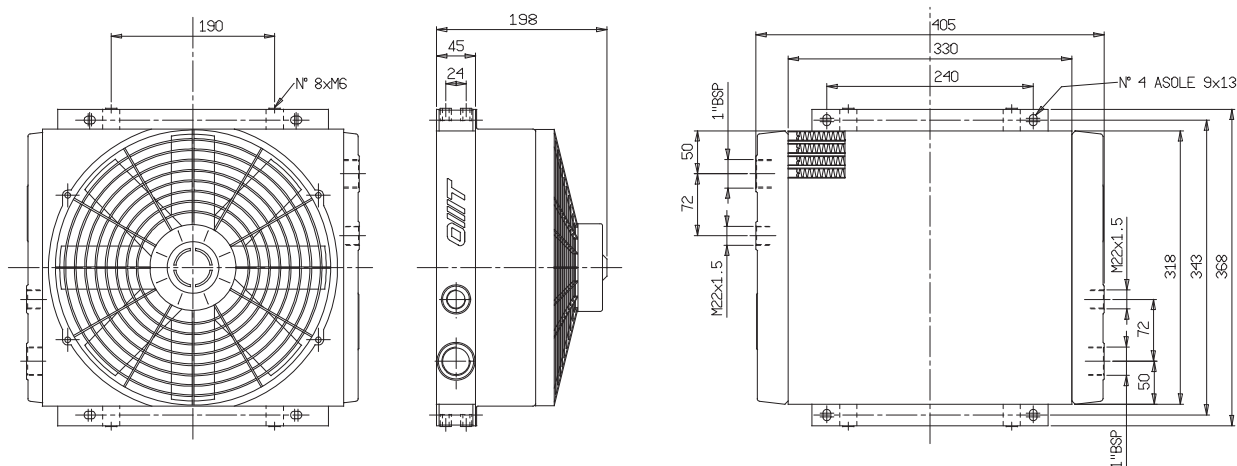

COEFFICIENTE DI CORREZIONE CORRECTION FACTOR

CST	10	15	20	32	40	50	60	80	100	200
F	0.51	0.66	0.76	1	1.22	1.4	1.6	1.9	2.1	3.4

DIAGRAMMA DI RENDIMENTO PERFORMANCE DIAGRAM



DIAGRAMMA PERDITE DI CARICO (32 cst) PRESSURE DROP DIAGRAM (32 cst)



Le dimensioni di ingombro e le caratteristiche tecniche non sono impegnative
Over-all dimensions and technical characteristic are not binding

Scambiatori di calore serie "ST100" aria-olio Air-oil heat exchangers series "ST100"

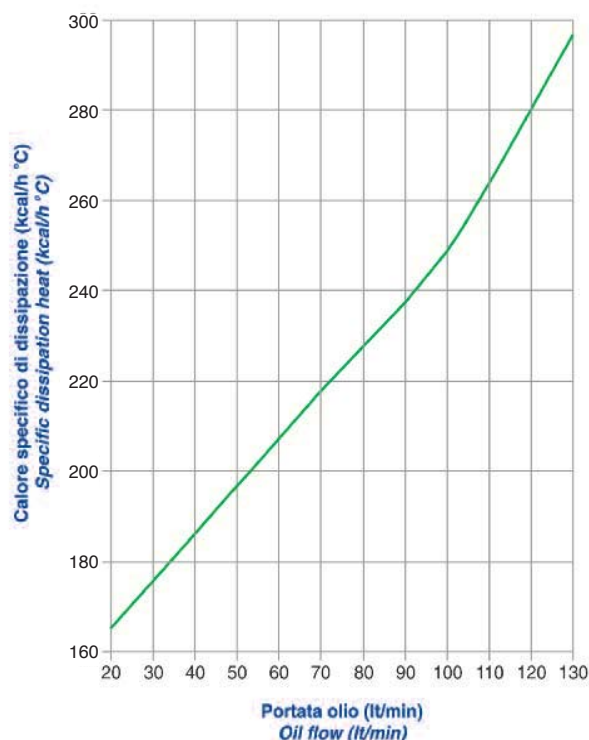
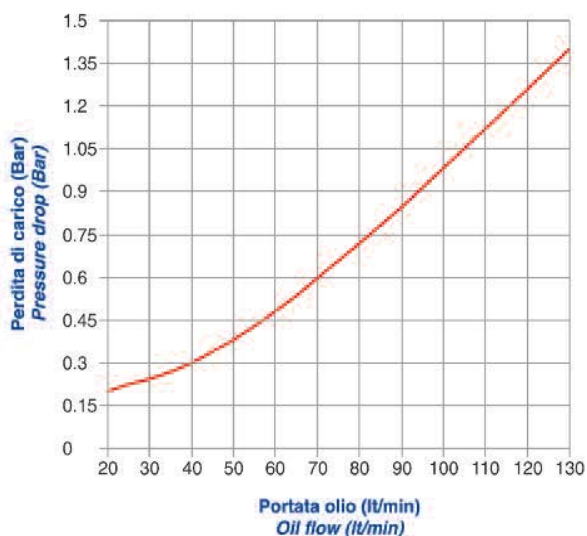

CARATTERISTICHE TECNICHE DEL GRUPPO DI VENTILAZIONE TECHNICAL FEATURES

Tipologia Type	Frequenza Frequency Hz	Tensione Voltage V	Giri/min RPM N.°	Potenza Power kW	Ø ventola Ø FAN (mm)	dB (A)	Q air (m³/h)	Cap. (lt)	Peso Weight (kg)	IP
12	DC	12	3000	0.175	305	79	2100	1.5	8.5	67
24	DC	24	3000	0.175	305	82	2200	1.5	8.5	67

Portata olio consigliata da 30 a 140 (lt/min)
Suggested oil flow from 30 to 140 (lt/min)

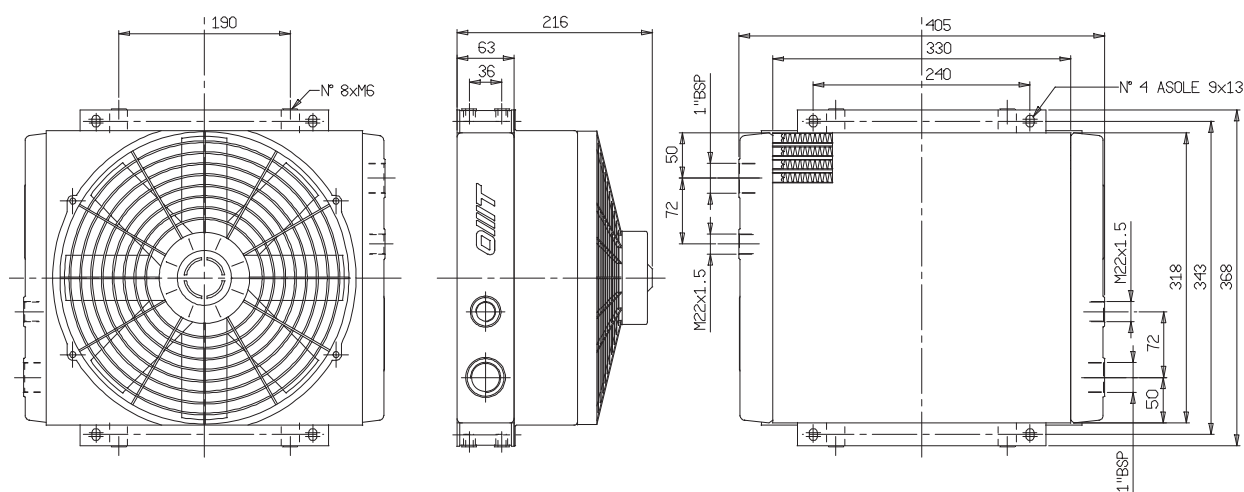

COEFFICIENTE DI CORREZIONE CORRECTION FACTOR

CST	10	15	20	32	40	50	60	80	100	200
F	0.51	0.66	0.76	1	1.22	1.4	1.6	1.9	2.1	3.4

DIAGRAMMA DI RENDIMENTO PERFORMANCE DIAGRAM



DIAGRAMMA PERDITE DI CARICO (32 cst) PRESSURE DROP DIAGRAM (32 cst)



Le dimensioni di ingombro e le caratteristiche tecniche non sono impegnative
Over-all dimensions and technical characteristic are not binding

Scambiatori di calore serie "ST150" aria-olio Air-oil heat exchangers series "ST150"

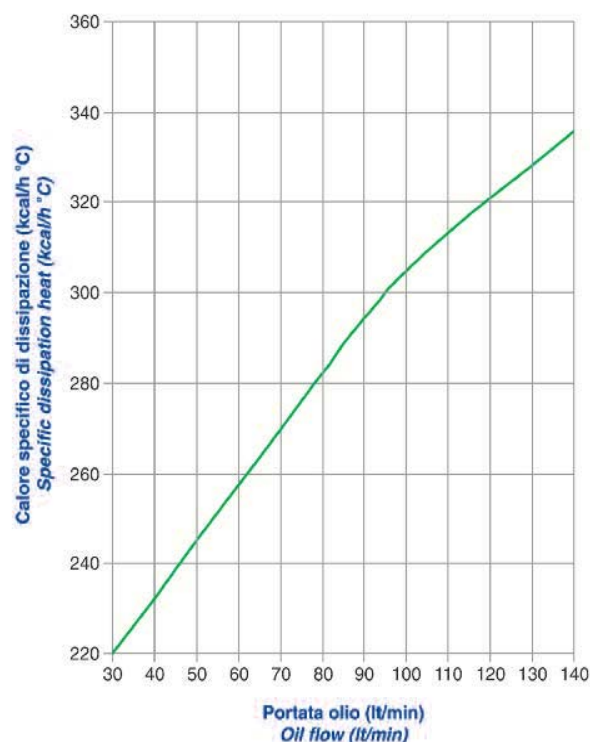
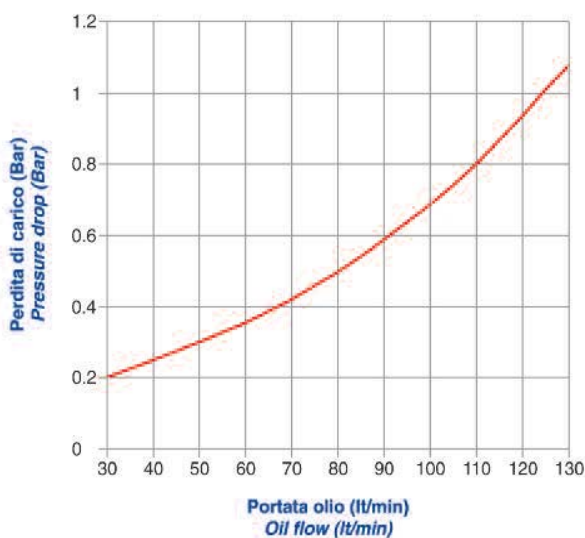

CARATTERISTICHE TECNICHE DEL GRUPPO DI VENTILAZIONE TECHNICAL FEATURES

Tipologia Type	Frequenza Frequency Hz	Tensione Voltage V	Giri/min RPM N.°	Potenza Power kW	Ø ventola Ø FAN (mm)	dB (A)	Q air (m³/h)	Cap. (lt)	Peso Weight (kg)	IP
12	DC	12	3000	0.175	305	79	2100	1.5	14	67
24	DC	24	3000	0.175	305	82	2200	1.5	14	67

Portata olio consigliata da 35 a 140 (lt/min)
Suggested oil flow from 35 to 140 (lt/min)

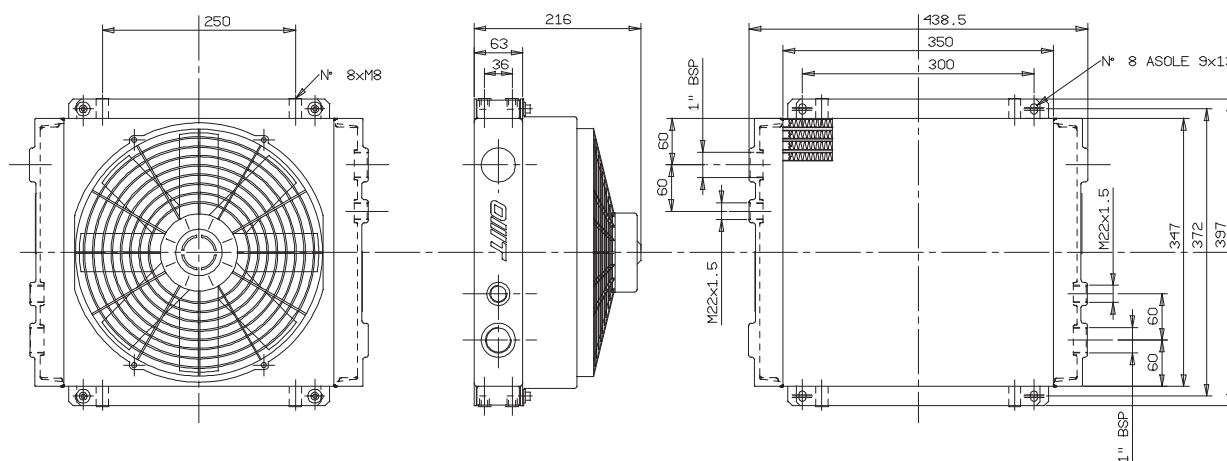

COEFFICIENTE DI CORREZIONE CORRECTION FACTOR

CST	10	15	20	32	40	50	60	80	100	200
F	0.51	0.66	0.76	1	1.22	1.4	1.6	1.9	2.1	3.4

DIAGRAMMA DI RENDIMENTO PERFORMANCE DIAGRAM



DIAGRAMMA PERDITE DI CARICO (32 cst) PRESSURE DROP DIAGRAM (32 cst)



Le dimensioni di ingombro e le caratteristiche tecniche non sono impegnative
Over-all dimensions and technical characteristic are not binding

Scambiatori di calore serie "ST180" aria-olio Air-oil heat exchangers series "ST180"

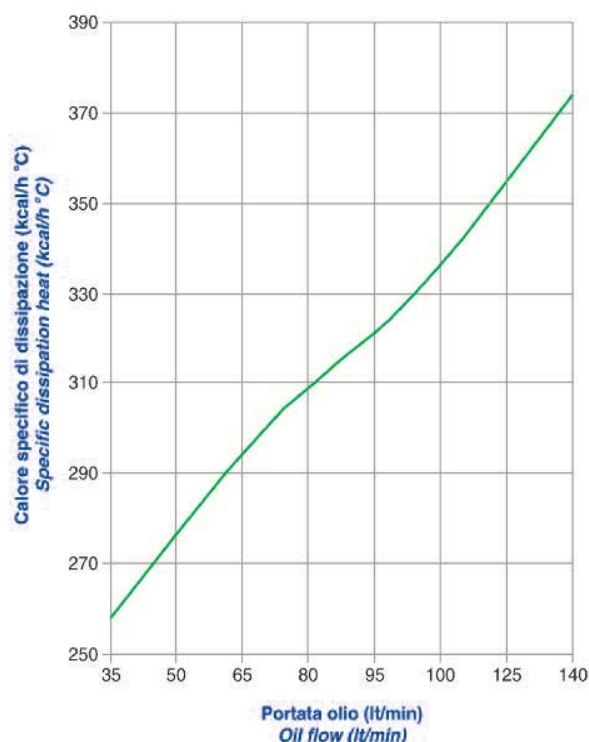
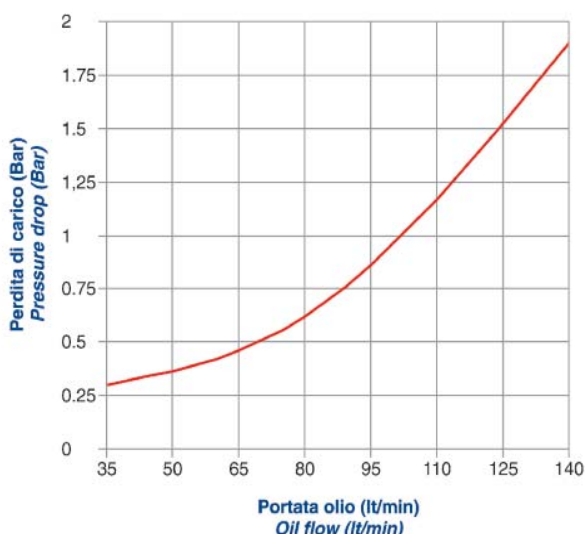

CARATTERISTICHE TECNICHE DEL GRUPPO DI VENTILAZIONE TECHNICAL FEATURES

Tipologia Type	Frequenza Frequency Hz	Tensione Voltage V	Giri/min RPM N.°	Potenza Power kW	Ø ventola Ø FAN (mm)	dB (A)	Q air (m³/h)	Cap. (lt)	Peso Weight (kg)	IP
12	DC	12	2500	0.2	385	75	3200	2.6	20	65
24	DC	24	2500	0.2	385	78	3500	2.6	20	65

Portata olio consigliata da 80 a 180 (lt/min)
Suggested oil flow from 80 to 180 (lt/min)

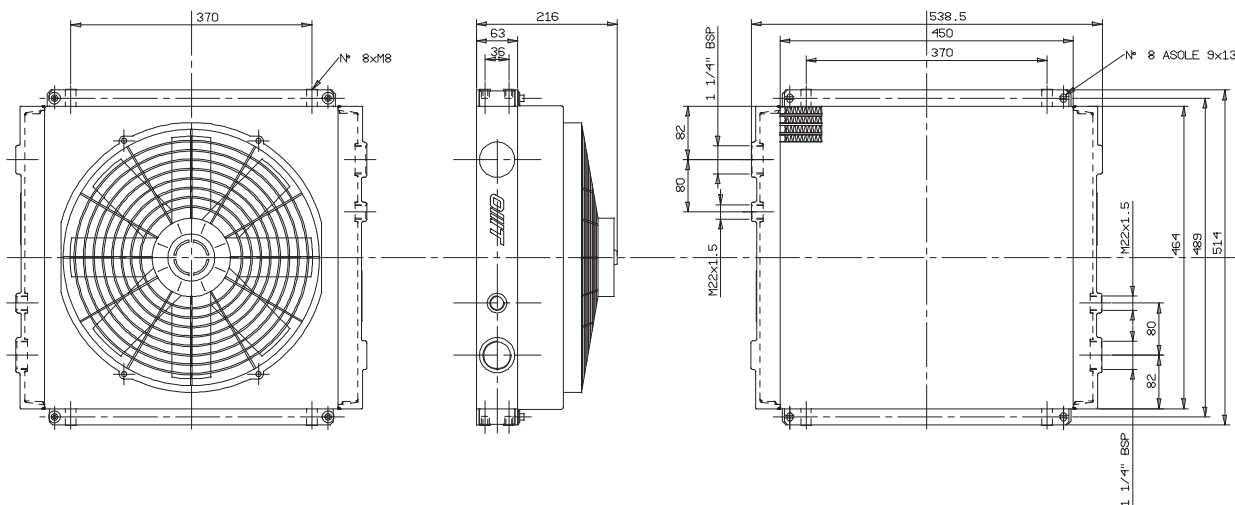

COEFFICIENTE DI CORREZIONE CORRECTION FACTOR

CST	10	15	20	32	40	50	60	80	100	200
F	0.51	0.66	0.76	1	1.22	1.4	1.6	1.9	2.1	3.4

DIAGRAMMA DI RENDIMENTO PERFORMANCE DIAGRAM



DIAGRAMMA PERDITE DI CARICO (32 cst) PRESSURE DROP DIAGRAM (32 cst)



Le dimensioni di ingombro e le caratteristiche tecniche non sono impegnative
Over-all dimensions and technical characteristic are not binding

Scambiatori di calore serie "ST210" aria-olio Air-oil heat exchangers series "ST210"

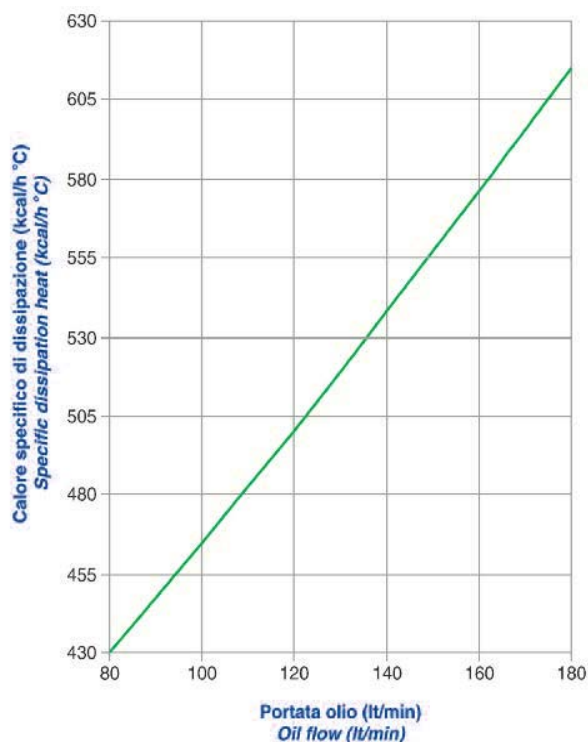
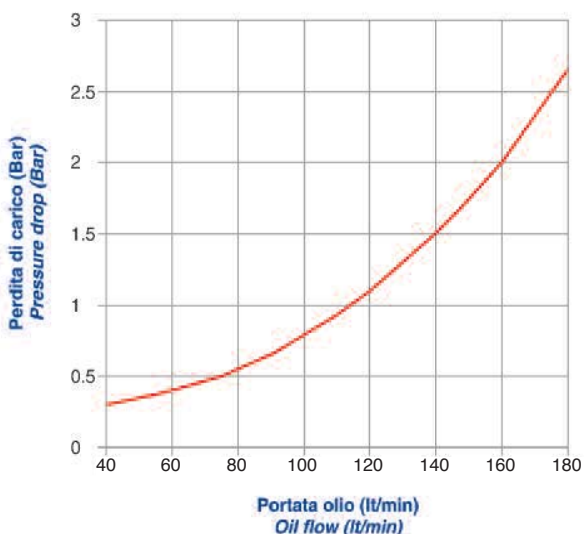

CARATTERISTICHE TECNICHE DEL GRUPPO DI VENTILAZIONE TECHNICAL FEATURES

Tipologia Type	Frequenza Frequency Hz	Tensione Voltage V	Giri/min RPM N.°	Potenza Power kW	Ø ventola Ø FAN (mm)	dB (A)	Q air (m³/h)	Cap. (lt)	Peso Weight (kg)	IP
12	DC	12	2500	0.2	385	75	3200	2.6	26	65
24	DC	24	2500	0.2	385	78	3500	2.6	26	65

Portata olio consigliata da 80 a 260 (lt/min)
Suggested oil flow from 80 to 260 (lt/min)

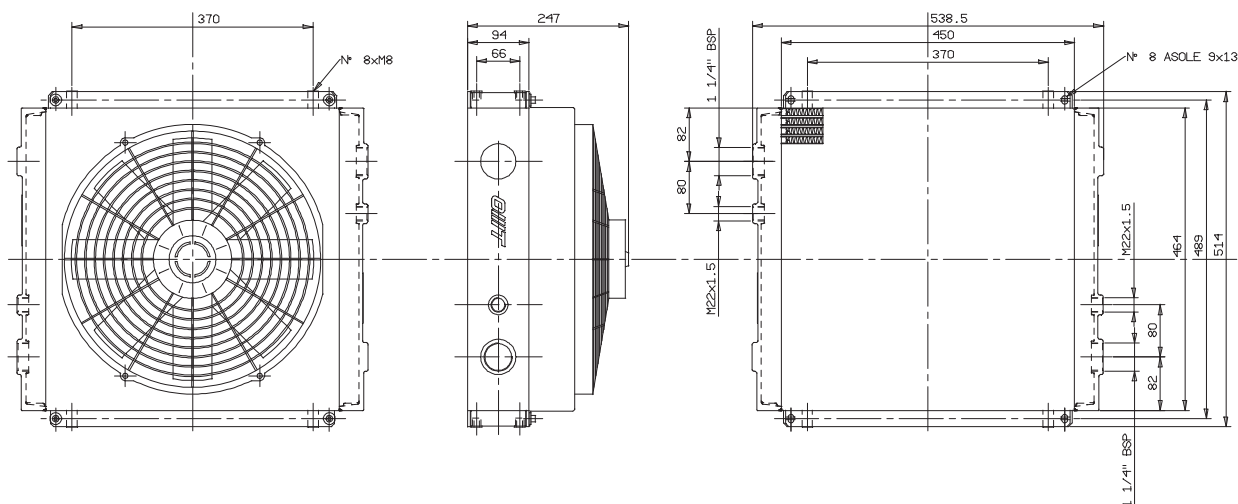

COEFFICIENTE DI CORREZIONE CORRECTION FACTOR

CST	10	15	20	32	40	50	60	80	100	200
F	0.51	0.66	0.76	1	1.22	1.4	1.6	1.9	2.1	3.4

DIAGRAMMA DI RENDIMENTO PERFORMANCE DIAGRAM



DIAGRAMMA PERDITE DI CARICO (32 cst) PRESSURE DROP DIAGRAM (32 cst)



Le dimensioni di ingombro e le caratteristiche tecniche non sono impegnative
Over-all dimensions and technical characteristics are not binding

Scambiatori di calore serie "ST250" aria-olio Air-oil heat exchangers series "ST250"

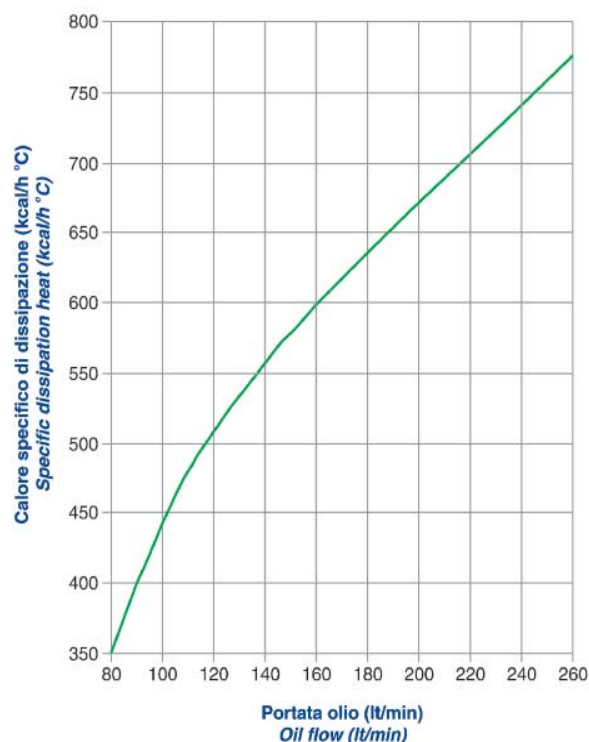
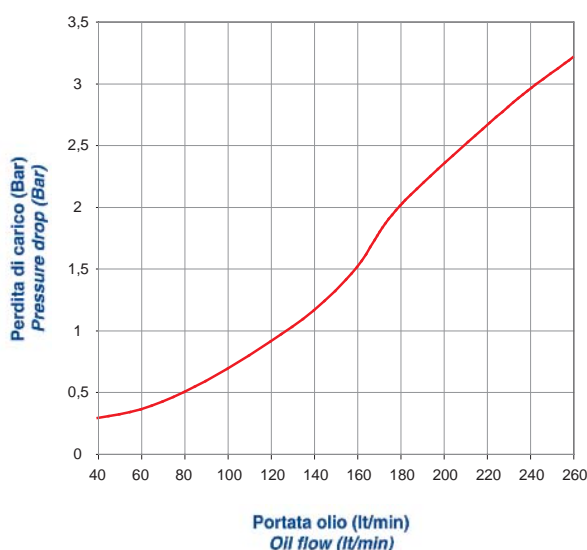

CARATTERISTICHE TECNICHE DEL GRUPPO DI VENTILAZIONE TECHNICAL FEATURES

Tipologia Type	Frequenza Frequency Hz	Tensione Voltage V	Giri/min RPM N.°	Potenza Power kW	Ø ventola Ø FAN (mm)	dB (A)	Q air (m³/h)	Cap. (lt)	Peso Weight (kg)	IP
12	DC	12	3100	0.1	190	68	1300	0.48	6.5	67
24	DC	24	3000	0.1	190	68	1300	0.48	6.5	67

Portata olio consigliata da 5 a 40 (lt/min)
Suggested oil flow from 5 to 40 (lt/min)

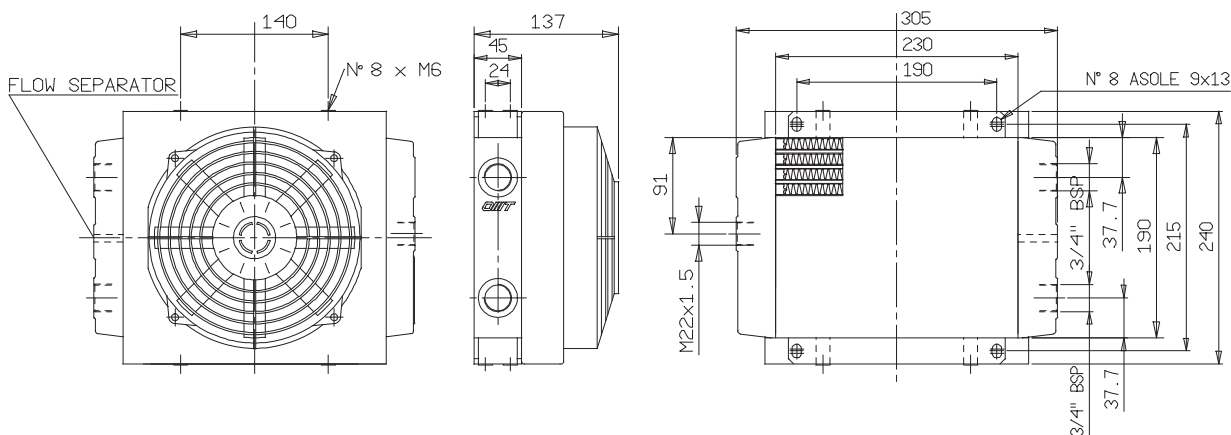

COEFFICIENTE DI CORREZIONE CORRECTION FACTOR

CST	10	15	20	32	40	50	60	80	100	200
F	0.51	0.66	0.76	1	1.22	1.4	1.6	1.9	2.1	3.4

DIAGRAMMA DI RENDIMENTO PERFORMANCE DIAGRAM



DIAGRAMMA PERDITE DI CARICO (32 cst) PRESSURE DROP DIAGRAM (32 cst)



Le dimensioni di ingombro e le caratteristiche tecniche non sono impegnative
Over-all dimensions and technical characteristic are not binding

Scambiatori di calore serie "ST260" aria-olio

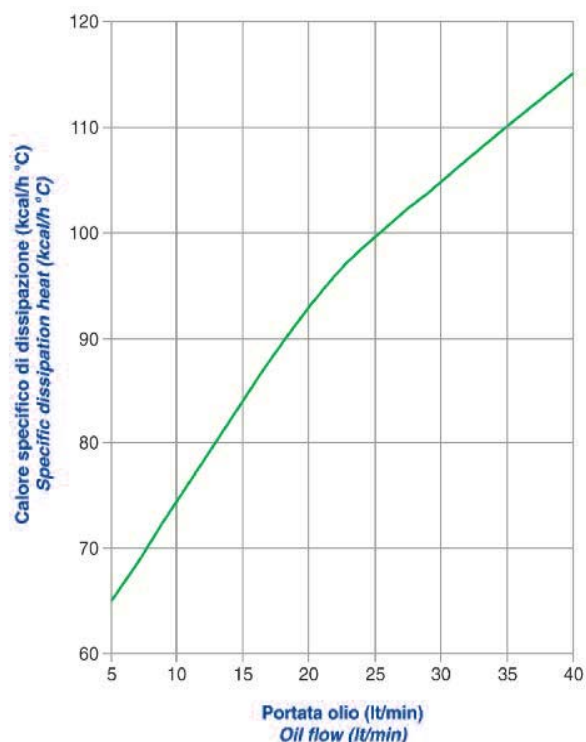
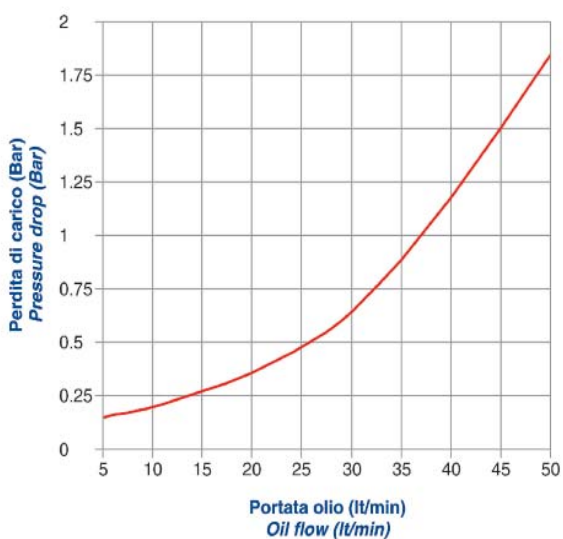
Air-oil heat exchangers series "ST260"



CARATTERISTICHE TECNICHE DEL GRUPPO DI VENTILAZIONE

TECHNICAL FEATURES

Tipologia Type	Frequenza Frequency Hz	Tensione Voltage V	Giri/min RPM N.°	Potenza Power kW	Ø ventola Ø FAN (mm)	dB (A)	Q air (m ³ /h)	Cap. (lt)	Peso Weight (kg)	IP
12	DC	12	3000	0.175	305	79	2100	1.5	7.5	67
24	DC	24	3000	0.175	305	82	2200	1.5	7.5	67

Portata olio consigliata da 10 a 65 (lt/min)
Suggested oil flow from 10 to 65 (lt/min)

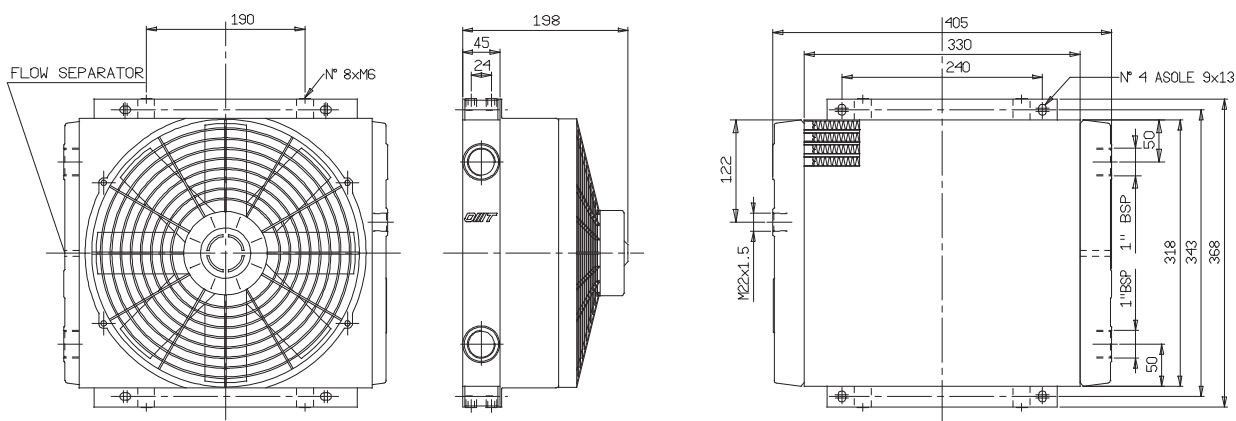

COEFFICIENTE DI CORREZIONE

CORRECTION FACTOR

CST	10	15	20	32	40	50	60	80	100	200
F	0.51	0.66	0.76	1	1.22	1.4	1.6	1.9	2.1	3.4

DIAGRAMMA DI RENDIMENTO

PERFORMANCE DIAGRAM



DIAGRAMMA PERDITE DI CARICO (32 cst)

PRESSURE DROP DIAGRAM (32 cst)

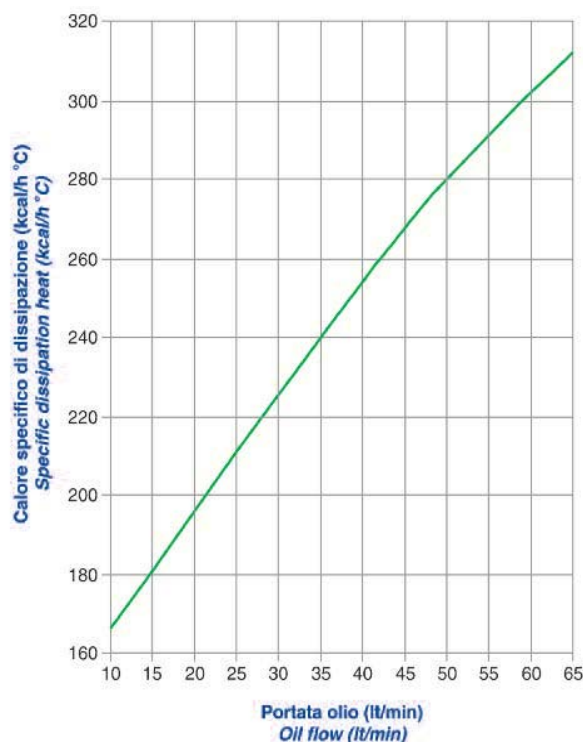
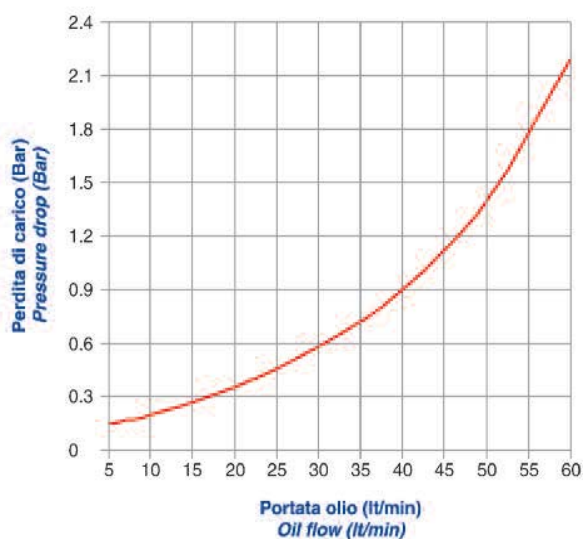

Le dimensioni di ingombro e le caratteristiche tecniche non sono impegnative
Over-all dimensions and technical characteristics are not binding

Scambiatori di calore serie "ST2100" aria-olio Air-oil heat exchangers series "ST2100"



CARATTERISTICHE TECNICHE DEL GRUPPO DI VENTILAZIONE TECHNICAL FEATURES

Tipologia Type	Frequenza Frequency Hz	Tensione Voltage V	Giri/min RPM N.°	Potenza Power kW	Ø ventola Ø FAN (mm)	dB (A)	Q air (m³/h)	Cap. (lt)	Peso Weight (kg)	IP
12	DC	12	3000	0.175	305	79	2100	1.5	8.5	67
24	DC	24	3000	0.175	305	82	2200	1.5	8.5	67

Portata olio consigliata da 15 a 70 (lt/min)
Suggested oil flow from 15 to 70 (lt/min)

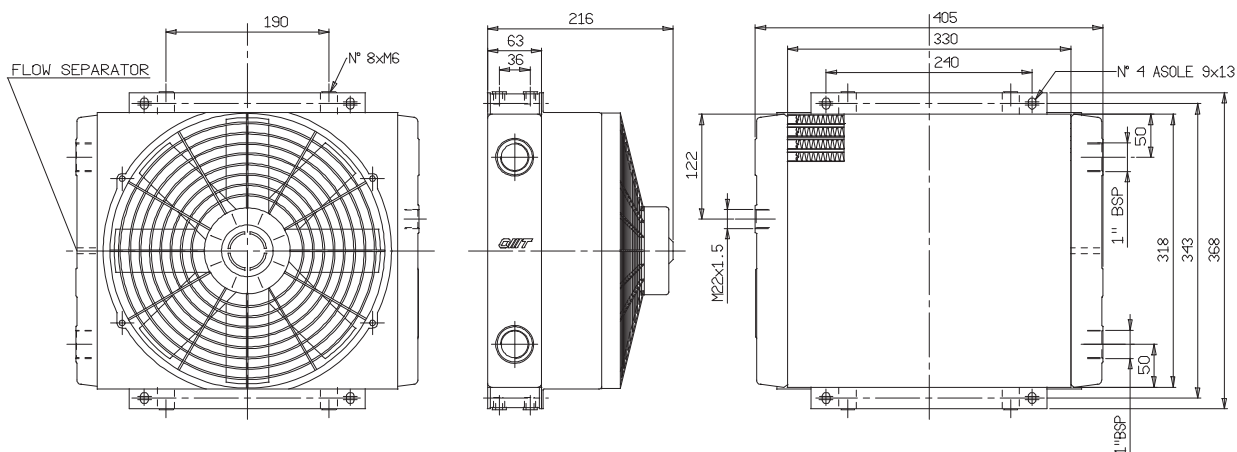

COEFFICIENTE DI CORREZIONE CORRECTION FACTOR

CST	10	15	20	32	40	50	60	80	100	200
F	0.51	0.66	0.76	1	1.22	1.4	1.6	1.9	2.1	3.4

DIAGRAMMA DI RENDIMENTO PERFORMANCE DIAGRAM



DIAGRAMMA PERDITE DI CARICO (32 cst) PRESSURE DROP DIAGRAM (32 cst)



Le dimensioni di ingombro e le caratteristiche tecniche non sono impegnative
Over-all dimensions and technical characteristic are not binding

Scambiatori di calore serie "ST2150" aria-olio Air-oil heat exchangers series "ST2150"

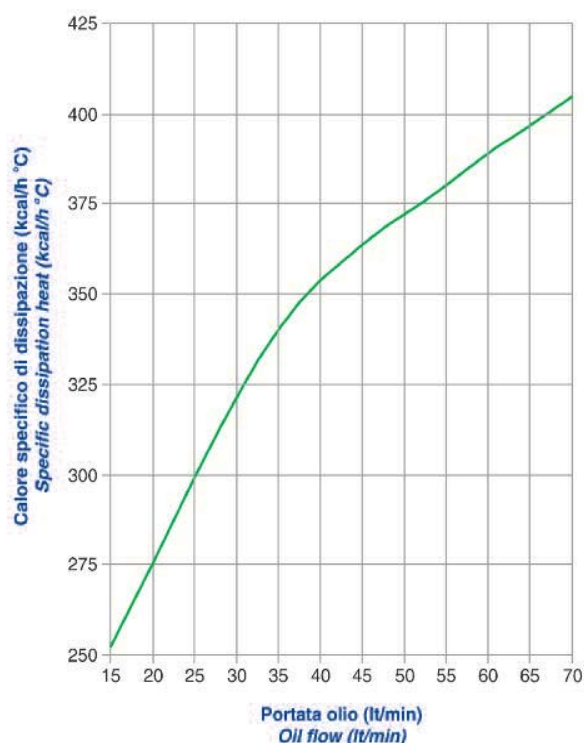
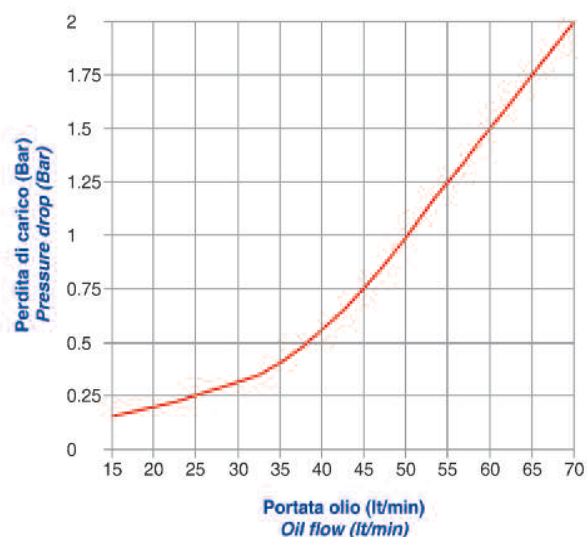

CARATTERISTICHE TECNICHE DEL GRUPPO DI VENTILAZIONE TECHNICAL FEATURES

Tipologia Type	Frequenza Frequency Hz	Tensione Voltage V	Giri/min RPM N.°	Potenza Power kW	Ø ventola Ø FAN (mm)	dB (A)	Q air (m³/h)	Cap. (lt)	Peso Weight (kg)	IP
12	DC	12	3000	0.175	305	79	2100	1.5	14	67
24	DC	24	3000	0.175	305	82	2200	1.5	14	67

Portata olio consigliata da 20 a 70 (lt/min)
Suggested oil flow from 20 to 70 (lt/min)

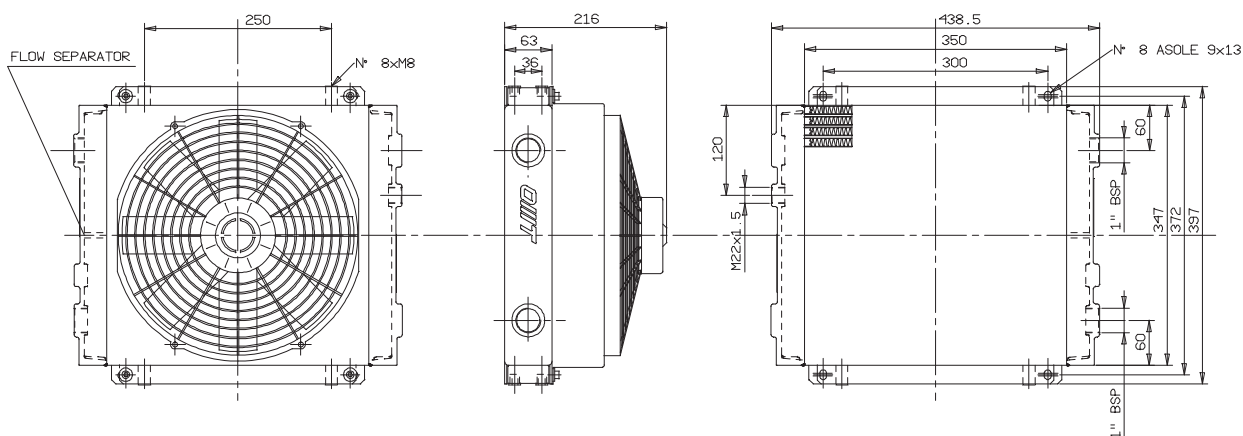

COEFFICIENTE DI CORREZIONE CORRECTION FACTOR

CST	10	15	20	32	40	50	60	80	100	200
F	0.51	0.66	0.76	1	1.22	1.4	1.6	1.9	2.1	3.4

DIAGRAMMA DI RENDIMENTO PERFORMANCE DIAGRAM



DIAGRAMMA PERDITE DI CARICO (32 cst) PRESSURE DROP DIAGRAM (32 cst)



Le dimensioni di ingombro e le caratteristiche tecniche non sono impegnative
Over-all dimensions and technical characteristic are not binding

Scambiatori di calore serie "ST2180" aria-olio Air-oil heat exchangers series "ST2180"

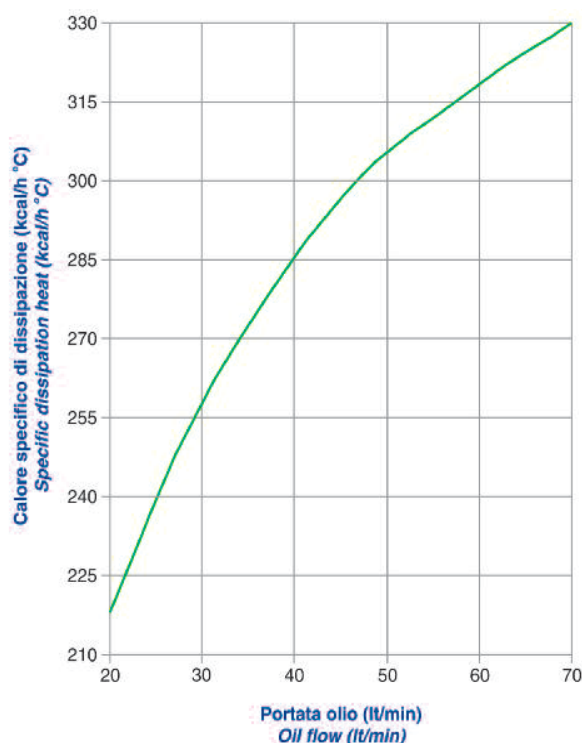
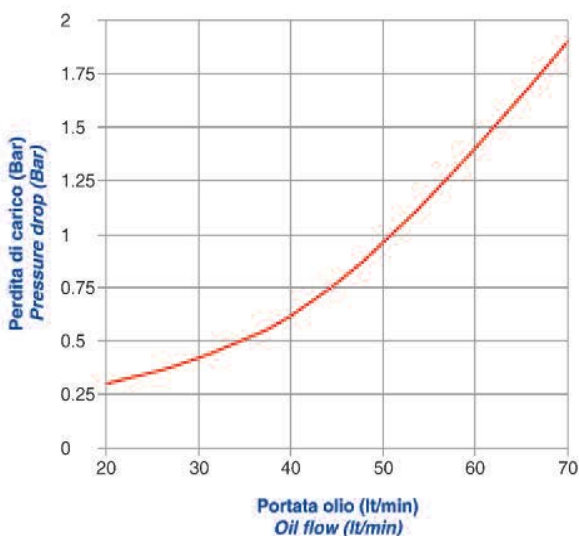

CARATTERISTICHE TECNICHE DEL GRUPPO DI VENTILAZIONE TECHNICAL FEATURES

Tipologia Type	Frequenza Frequency Hz	Tensione Voltage V	Giri/min RPM N.°	Potenza Power kW	Ø ventola Ø FAN (mm)	dB (A)	Q air (m³/h)	Cap. (lt)	Peso Weight (kg)	IP
12	DC	12	2500	0.2	385	75	3200	2.6	20	65
24	DC	24	2500	0.2	385	78	3500	2.6	20	65

Portata olio consigliata da 40 a 100 (lt/min)
Suggested oil flow from 40 to 100 (lt/min)

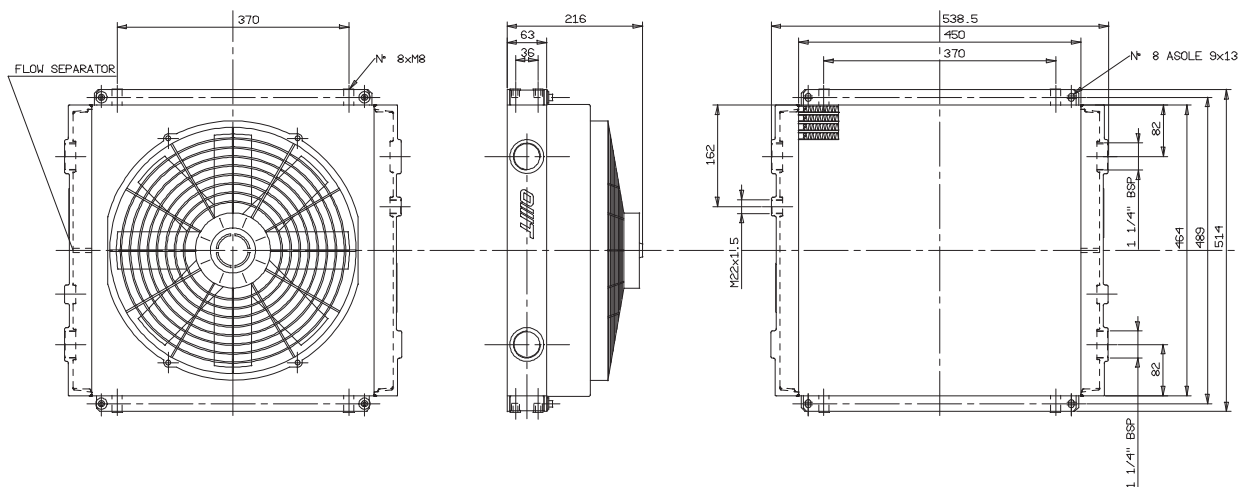

COEFFICIENTE DI CORREZIONE CORRECTION FACTOR

CST	10	15	20	32	40	50	60	80	100	200
F	0.51	0.66	0.76	1	1.22	1.4	1.6	1.9	2.1	3.4

DIAGRAMMA DI RENDIMENTO PERFORMANCE DIAGRAM



DIAGRAMMA PERDITE DI CARICO (32 cst) PRESSURE DROP DIAGRAM (32 cst)



Le dimensioni di ingombro e le caratteristiche tecniche non sono impegnative
Over-all dimensions and technical characteristic are not binding

Scambiatori di calore serie "ST2210" aria-olio Air-oil heat exchangers series "ST2210"

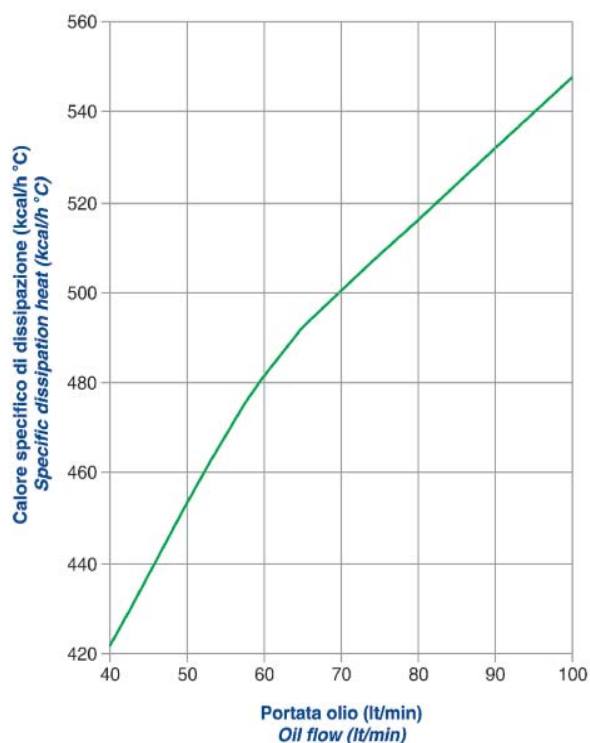
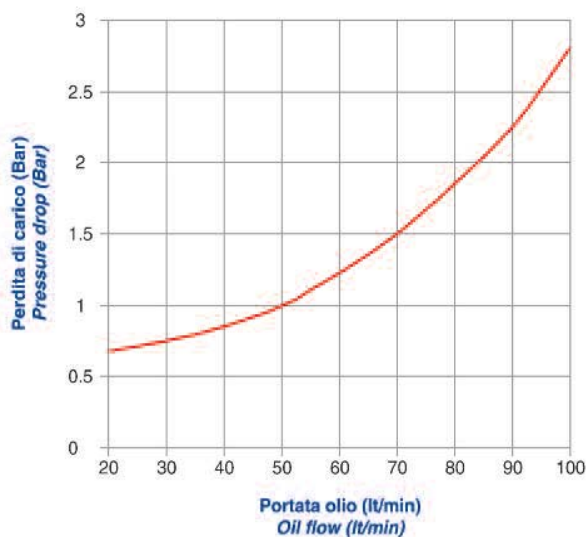

CARATTERISTICHE TECNICHE DEL GRUPPO DI VENTILAZIONE TECHNICAL FEATURES

Tipologia Type	Frequenza Frequency Hz	Tensione Voltage V	Giri/min RPM N.°	Potenza Power kW	Ø ventola Ø FAN (mm)	dB (A)	Q air (m³/h)	Cap. (lt)	Peso Weight (kg)	IP
12	DC	12	2500	0.2	385	75	3200	2.6	26	65
24	DC	24	2500	0.2	385	78	3500	2.6	26	65

Portata olio consigliata da 40 a 140 (lt/min)
Suggested oil flow from 40 to 140 (lt/min)

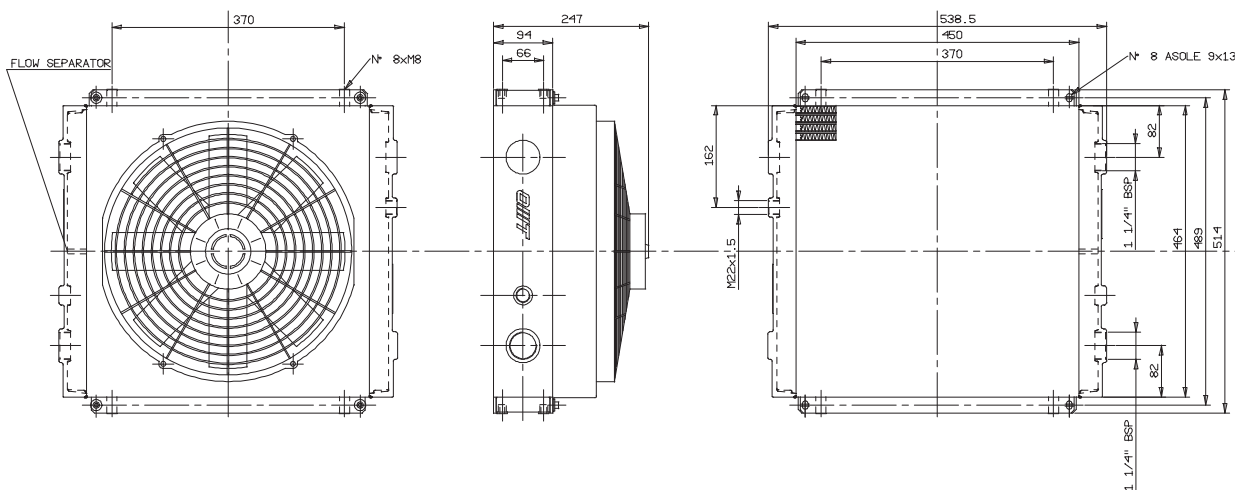

COEFFICIENTE DI CORREZIONE CORRECTION FACTOR

CST	10	15	20	32	40	50	60	80	100	200
F	0.51	0.66	0.76	1	1.22	1.4	1.6	1.9	2.1	3.4

DIAGRAMMA DI RENDIMENTO PERFORMANCE DIAGRAM



DIAGRAMMA PERDITE DI CARICO (32 cst) PRESSURE DROP DIAGRAM (32 cst)



Le dimensioni di ingombro e le caratteristiche tecniche non sono impegnative
Over-all dimensions and technical characteristic are not binding

Scambiatori di calore serie "SDT50" aria-olio Air-oil heat exchangers series "SDT50"

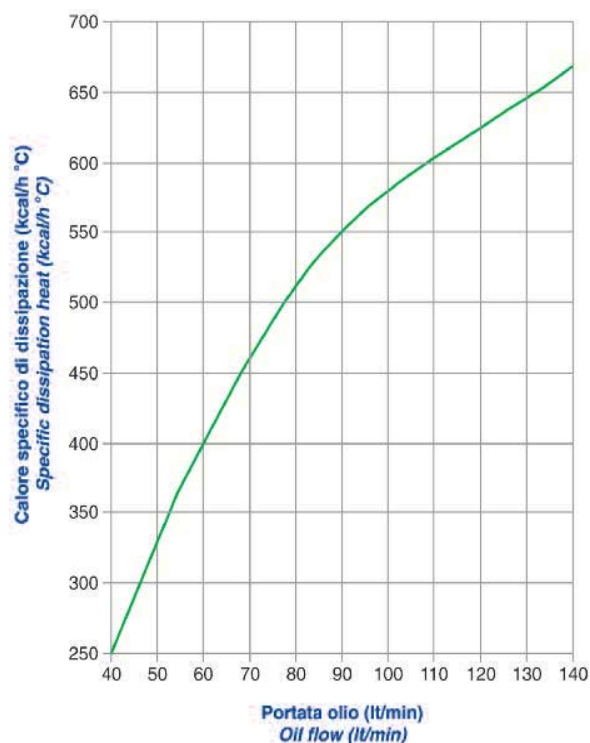
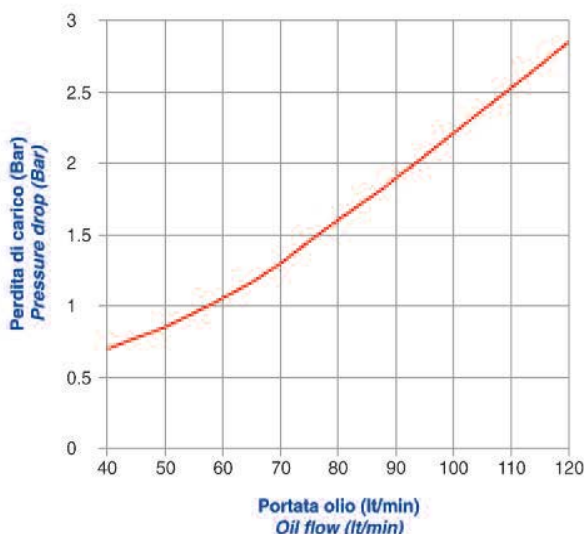

CARATTERISTICHE TECNICHE DEL GRUPPO DI VENTILAZIONE TECHNICAL FEATURES

Tipologia Type	Frequenza Frequency Hz	Tensione Voltage V	Giri/min RPM N.°	Potenza Power kW	Ø ventola Ø FAN (mm)	dB (A)	Q air (m³/h)	Cap. (lt)	Peso Weight (kg)	IP
12	DC	12	3100	0.1	190	68	1300	0.9	10	67
24	DC	24	3000	0.1	190	68	1300	0.9	10	67

Portata olio consigliata da 10 a 80 (lt/min)
Suggested oil flow from 10 to 80 (lt/min)

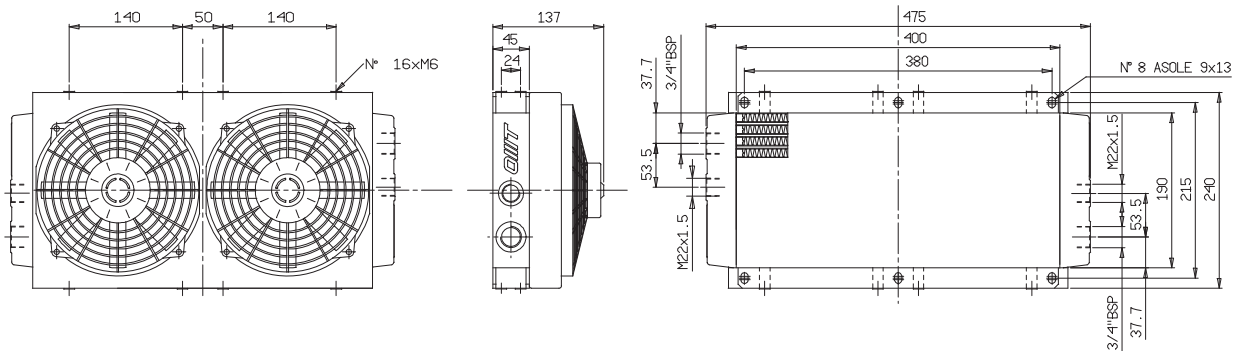

COEFFICIENTE DI CORREZIONE CORRECTION FACTOR

CST	10	15	20	32	40	50	60	80	100	200
F	0.51	0.66	0.76	1	1.22	1.4	1.6	1.9	2.1	3.4

DIAGRAMMA DI RENDIMENTO PERFORMANCE DIAGRAM



DIAGRAMMA PERDITE DI CARICO (32 cst) PRESSURE DROP DIAGRAM (32 cst)



Le dimensioni di ingombro e le caratteristiche tecniche non sono impegnative
Over-all dimensions and technical characteristic are not binding

TERMOSTATO BIMETALLICO FISSO - BIMETALLIC FIXED TEMPERATURE SWITCH

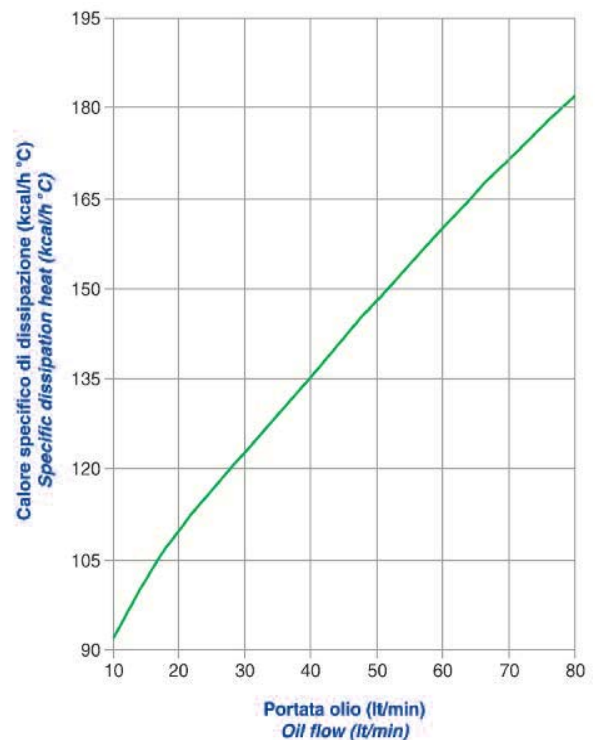
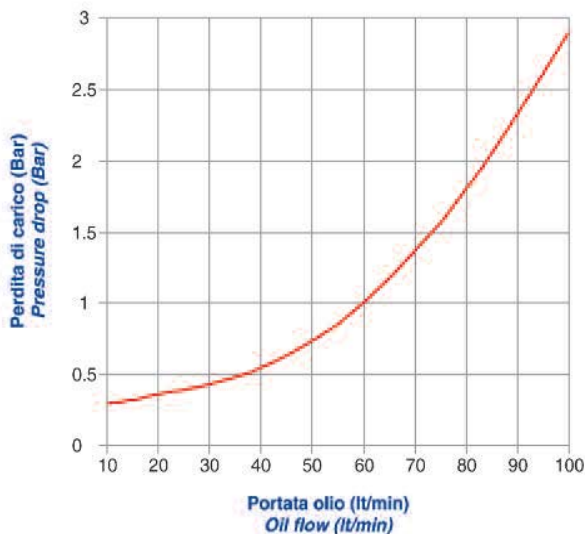
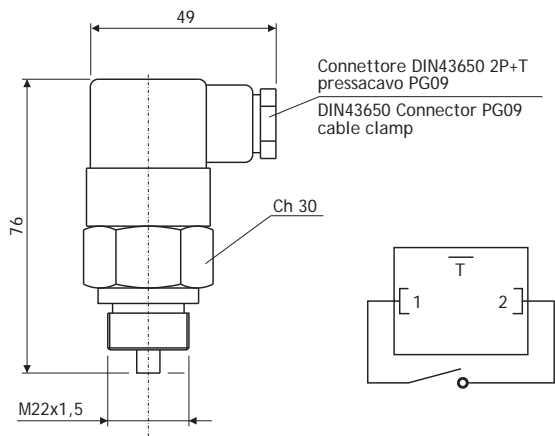

Codice termostato Switch part number	Temperatura d'intervento Working temperature	Contatto Contact
T01 - M22x1,5	36-26°C	NA/NO
T02 - M22x1,5	42-33°C	NA/NO
T03 - M22x1,5	52-42°C	NA/NO
T04 - M22x1,5	65-55°C	NA/NO
T05 - M22x1,5	75-65°C	NA/NO
T06 - M22x1,5	85-75°C	NA/NO
T07 - M22x1,5	95-85°C	NA/NO

NA=normalmente aperto / NO=normally open

Dati elettrici / Electrical data

Tensione max. / Max. voltage	250Vca
Corrente max. / Max. current	10A
Tolleranza intervento / Tolerance	±5°C
Differenziale fisso max. / Fixed hysteresis max.	15°C
Connessione elettrica / Electrical connection	DIN43650
Protezione elettrica / Protection degree	IP65
Temperatura max. / Max temperature	130°C

Materiali / Materials

Corpo / Body	Ottone / Brass
Contatti / Contacts	Argentati / Silver plated

TERMOSTATO BIMETALLICO FISSO - BIMETALLIC FIXED TEMPERATURE SWITCH

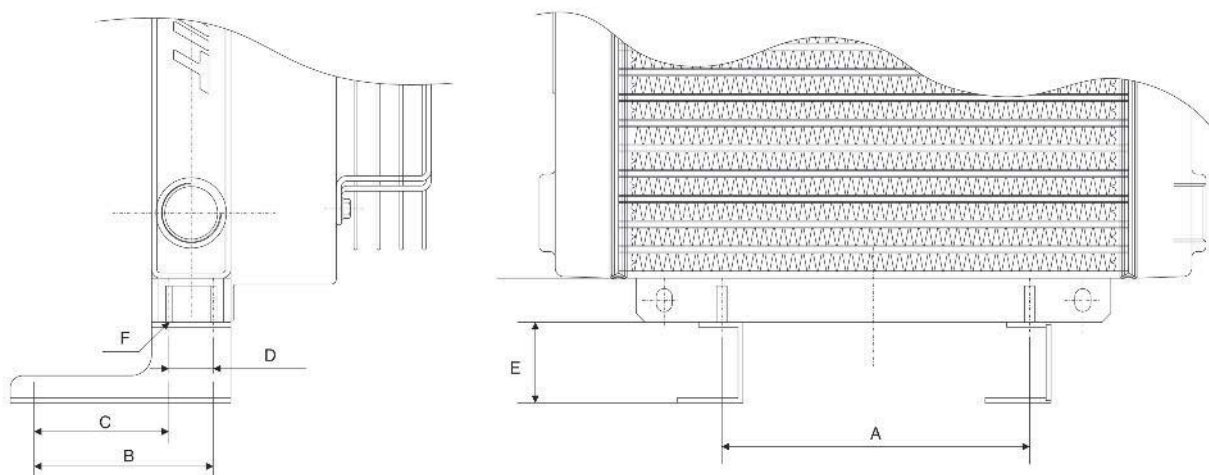

Tipo Type	Staffe di fissaggio Foot flanges	A	B	C	D	E	F
ST50	P-SSA50 - VN	140	125	101	24	45	M6
ST60	P-SSA50 - VN	190	125	101	24	45	M6
ST100	P-SSA100 - VN	190	127	91	36	50	M6
ST150	P-SSA100 - VN	250	127	91	36	50	M8
ST180	P-SSA100 - VN	370	127	91	36	50	M8
ST210	P-SSA210 - VN	370	144	78	66	50	M8
STD50	P-SSA50 - VN	pag. 15	125	101	24	45	M6

CODICE PER L'ORDINAZIONE
HOW TO ORDER
ST



ST50

12

02

A - P

Tipologia di scambiatore
Type

ST50
ST60
ST100
ST150
ST180
ST210
ST250
ST260
ST2100
ST2150
ST2180
ST2210
STD50

Termostati bimetallici fissi
Bimetallic fixed temperature switches

00	Senza termostato / No switch
01	Termostato fisso / Fixed switch 36-26 °C
02	Termostato fisso / Fixed switch 43-33 °C
03	Termostato fisso / Fixed switch 52-42 °C
04	Termostato fisso / Fixed switch 65-55 °C
05	Termostato fisso / Fixed switch 75-65 °C
06	Termostato fisso / Fixed switch 85-75 °C
07	Termostato fisso / Fixed switch 95-85 °C

Optionals

P	Con staffe di fissaggio With foot flanges
---	--

Tipi di ventilazione
Fans

A	Aspirante / Drawing
S	Soffiante / Blower

Tipi di ventilazione
Fan Motor

12	12V CC
24	24V CC

APPLICAZIONI SPECIALI

Per tutte le applicazioni che non rientrano nei casi normali specificati in questo catalogo contattare l'ufficio commerciale della OMT per un eventuale studio di fattibilità.

SPECIAL APPLICATIONS

For special solutions or particular applications, please contact OMT commercial department for informations.

SCAMBIATORI
HEAT EXCHANGERS

FILTRI
FILTERS

ACCESSORI
ACCESSORIES

COMPONENTI
COMPONENTS

FLANGE / FLANGES
RACCORDI / COUPLINGS
BLOCCHI / MANIFOLDS



OMIT