

AXIAL FANS

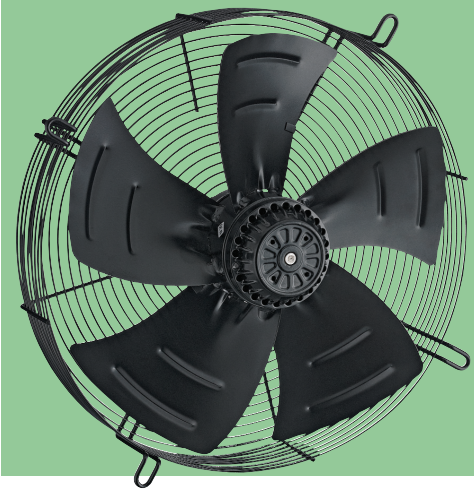

4M-4T

AC COOLING FANS Single Phase & Three Phase

With suction and blowing types, 4M-4T cooling fans work trouble-free at high performance.

Technical Drawings

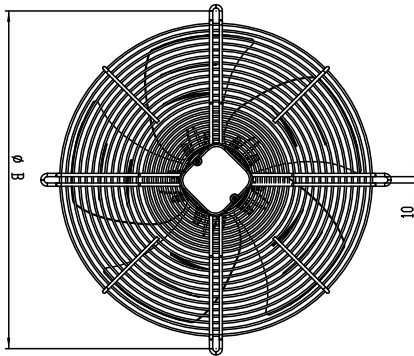
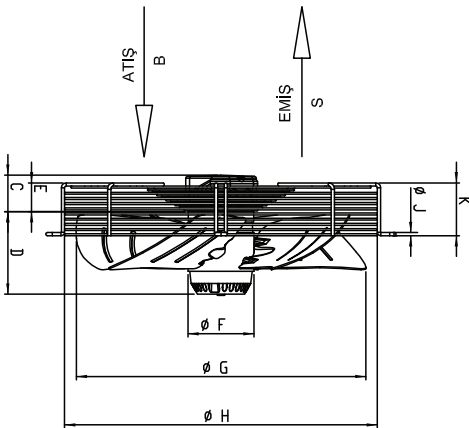

MATERIAL

: Casing is made of electrostatic (black) powder coated sheet steel; impeller is made of sheet steel with an aerodynamic structure and connected to the motor.

ROTATION

: CW (Clockwise)

INSULATION CLASS

: Class B & Class F

DIRECTIVE

: EN 60335-1, EN 60335-2-80

APPLICATION AREAS

: Cooling units, laboratories, cooling towers, cold stores etc.

TYPE	VOLTAGE	FREQUENCY	POWER	CURRENT	CAPACITOR	SPEED	AIR FLOW	SOUND PRESSURE LEVEL	WEIGHT
	V	Hz	W	(A)	(μ F)	d/d	m ³ /h	dB(A)	kg
4M 250B/S	230	50	50	0,22	1,5	1380	1000	50	2.5
4M 300B/S	230	50	90	0,38	3	1370	1700	55	4
4M 350B/S	230	50	138	0,68	4	1370	2900	62	4.7
4M 400B/S	230	50	190	0,7	6	1350	3830	67	6.1
4M 450B/S	230	50	220	1,2	8	1380	4800	71	6.9
4M 500B/S	230	50	420	1,85	12	1320	6900	72	9.5
4T 300B/S	380	50	95	0,26	-	1400	1750	55	4
4T 350B/S	380	50	145	0,38	-	1390	2900	62	4.7
4T 400B/S	380	50	190	0,48	-	1380	3980	67	6.1
4T 450B/S	380	50	250	0,58	-	1400	4800	71	6.9
4T 500B/S	380	50	450	0,9	-	1320	6900	72	9.5

TYPE	A	B	C	D	E	F	G	H	J	K
4M 250	7	310	55	75	30	92	250	275	3	80
4M 300	7	360	55	82	30	92	300	322	4	80
4M 350	9	422	55	108	30	102	350	375	5	80
4M 400	9	470	55	121	30	102	391	422	5	90
4M 450	9	522	55	133	30	102	446	475	5	90
4M 500	10	567	65	127	30	138	449	525	6	90
4T 300	7	360	55	82	30	92	300	322	4	80
4T 350	9	422	55	108	30	102	350	375	5	80
4T 400	9	470	55	121	30	102	391	422	5	90
4T 450	9	522	55	133	30	102	446	475	5	90
4T 500	10	567	65	127	30	138	449	525	6	90

Dimensions are in (mm)

