

Solar Charger Controller Installation & Operation Manual



Contents

Important safety instructions	6
1. Product description	8
1.1 General description.....	8
1.2 Features.....	8
1.3 Maximum setpoint voltage limit.....	9
1.4 Temperature and output power.....	9
1.5 Maximum power point tracking (MPPT)	9
1.6 How MPPT works	9
1.7 Over voltage / reverse polarity protection	10
1.8 Electrostatic handling precautions	10
1.9 Solar charger controller setup	10
1.9.1 Factory default settings	10
1.10 Three stage charge control.....	10
1.10.1 Bulk charge	10
1.10.2 Absorption charge	11
1.10.3 Float charge.....	11
1.11 Battery temperature sensor (BTS)	11
1.12 Equalization charge	11
1.12.1 Photovoltaic charge and load controller.....	11
1.12.2 Automatic PV array night disconnect	12
1.12.3 Solar charger controller load control	12
1.12.4 Low voltage disconnect	12
1.12.5 Low voltage reconnect.....	12
1.13 Optional accessories	13
2. Installation	14
2.1 Pre-Installation.....	14
2.2 Removing the topcover.....	14
2.3 Mounting the Solar charger controller.....	14
2.3 Mounting the Solar charger controller.....	15
2.3.1 Mount the Solar charge controller	15
2.4 Configuring the Solar charge controller	16
2.4.1 Battery type selector can apply different charger method.....	16
2.5 Temperature compensation.....	18
2.5.2 Automatic battery temperature compensation.....	19
2.6 Grounding.....	19
2.7 DC terminal connector locations	20
2.8 Wire Size and Over-current Protection Requirements.....	20
2.8.1 Current Rating	21
2.8.2 Surge Protection.....	22
2.8.3 Over-current Protection	22
2.9 PV Charge And Load Control Mode Wiring.....	22
2.10 Easily install in parallel connection	24
2.11 Battery type selector	25
2.12 Installing Optional Accessories	26
2.13 Reinstalling the Faceplate.....	26
3. Operation	28
3.1 Basic Operation	28
3.2 LED Status Indicator	28
3.2.1 Charge control indications	28
4. Troubleshooting	30
5. Specifications	31
5.1 Specifications.....	31
5.2 Environmental.....	31
5.2.1 Temperature	31
5.3 Safety and EMC.....	32
5.3.2 European market: CE.....	32
5.4 Humidity	32
5.4.1 Operating Humidity	32

5.4.2 Non-Operating Humidity	32
5.5 Mechanical features	32
5.6 Detailed dimension drawing	33
6. Batteries	34
6.1 Battery Types.....	34
6.2 Automotive Batteries	34
6.3 Maintenance-Free Batteries	34
6.4 Deep-Cycle Batteries	34
6.5 Sealed Batteries	34
6.6 Battery Sizing	34
6.7 Equalization Charging	34
6.8 Equalization Setpoints (Non-Sealed Batteries Only).....	35

Tables

Table 1 – 1: Factory shipping settings	10
Table 1 – 2: Battery type selector switch settings.....	16
Table 1 – 3: Temperature compensation calculation.....	19
Table 1 – 4: Battery compensation coefficient.....	19
Table 1 – 5: Minimum wire size	22
Table 1 – 6: The LED indicators.....	29
Table 1 – 7: Troubleshooting list	30
Table 1 – 8: Electrical specification.....	31
Table 1 – 9: Mechanical specification	32
Table 1 – 10: Battery equalization	35

Figures

Figure 1 – 1: Bulk charge curve.....	10
Figure 1 – 2: PV charge and load controller	12
Figure 1 – 3: Load controller	12
Figure 1 – 4: Removing the topcover	14
Figure 1 – 5: Mounting the Solar charge controller.....	15
Figure 1 – 6: Battery type selector (B.SEL)	16
Figure 1 – 7: Safety (Earth) ground.....	20
Figure 1 – 8: DC terminal connector locations.....	20
Figure 1 – 9: PV charge control mode wiring.....	23
Figure 1 – 10: Parallel connection	24
Figure 1 – 11: battery type selector.....	25
Figure 1 – 12: Install BTS	26
Figure 1 – 13: Reinstalling the faceplate	27
Figure 1 – 14: LED status indicator.....	28
Figure 1 – 15: Solar charger controller dimension drawing	33

About This Manual

Purpose

The purpose of this manual is to provide explanations and procedures for installing, operating, maintaining, and troubleshooting the Solar charge controller.

Scope

This manual provides safety guidelines, detailed planning and setup information, procedures for installing the Solar charger controller, as well as information about operating and troubleshooting the unit. It does not provide details about particular brands of batteries. You need to consult individual battery manufacturers for this information.

Audience

This manual is intended for anyone who needs to install and operate the Solar charger controller. Installers should be certified technicians or electricians.

Organization

This Manual is organized into six chapters.

Chapter 1. Product description

Chapter 2. Installation

Chapter 3. Operation

Chapter 4. Troubleshooting

Chapter 5. Specification

Chapter 6. Battery

Important safety instructions

Save these instructions

This manual contains important instructions for Solar charger controller that shall be followed during installation and maintenance.

General

1. Refer installation and servicing to qualified service personnel. Incorrect installation or use may result in risk of fire. No user serviceable parts in this unit.

2. Remove all sources of power, photovoltaic and battery before servicing or installing.

3. Warning – risk of explosive gases

- ◆ When Solar charger controller is working, Please DO NOT touch it because the temperature is too high.
- ◆ Working in the vicinity of lead-acid batteries is dangerous. Batteries produce explosive gasses during normal battery operation.
- ◆ To reduce risk of battery explosion, follow these instructions and those published by battery manufacturer and manufacturer of any equipment you intend to use in vicinity of battery.

4. Personal precautions

- ◆ Someone should be within range of your voice or close enough to come to your aid when you work near a lead-acid battery.
- ◆ Have plenty of fresh water and soap nearby in case battery acid contacts skin, clothing or eyes.
- ◆ Wear complete eye protection and clothing protection. Avoid touching eyes while working near battery.
- ◆ If battery acid contacts skin or clothing, wash immediately with soap and water. If acid enters eye, immediately flood eye with running cold water for at least 10 minutes and get medical attention immediately.
- ◆ NEVER smoke or allow a spark or flame in vicinity of battery.
- ◆ Be extra cautious to reduce risk of dropping metal tool onto battery. It might spark or short circuit battery or other electrical part that may cause explosion.
- ◆ Remove personal metal items such as rings, bracelets, necklaces, and watches when working with a lead-acid battery. A lead-acid battery can produce a short circuit current high enough to weld a ring or the like to metal, causing a severe burn.

5. Preparing to charge

- ◆ Never charge a frozen battery.
- ◆ Be sure battery is mounted in a well-ventilated compartment.
- ◆ Add distilled water in each cell until battery acid reaches level specified by battery manufacturer. This helps purge excessive gas from the cells. Do not overfill. For a battery without cell caps, carefully follow manufacturers charging instructions.

6. Charger location & installation

- ◆ Controller employs components that tend to produce arcs or sparks. NEVER install in battery compartment or in the presence of explosive gases.
- ◆ Protect all wiring from physical damage, vibration and excessive heat.
- ◆ Insure that the controller is properly setup for the battery being charged.
- ◆ Do not expose controller to rain or snow.
- ◆ Insure all terminating connections are clean and tight to prevent arcing and overheating.
- ◆ Charging system must be properly installed as described in these instructions prior to operation.
- ◆ Do not connect to a PV array capable of producing greater than 40 amps of short circuit current @ 25°C.
- ◆ Do not connect input to DC source directly with load, Solar charger controller need to .be powered by solar panel.
- ◆ Do not short-circuit DC output port, it will damage Solar charger controller.

Symbol



--Warning



--Dangerous Voltage



--Alternative Current



--Direct Current



--Protective Earth



--ESD

Abbreviations and Acronyms

BTS	Battery Temperature Sensor
DC	Direct Current
LED	Light Emitting Diode
LVD	Low Voltage Disconnect
LVR	Low Voltage Reconnect
B.SELECT	Battery type selector
CHG.MODE	Charge mode
PV	Photovoltaic
MPPT	Maximum Power Point Tracking
PWM	Pulse Width Modulation
RE	Renewable Energy

1. Product description

1.1 General description

Solar charger controller is a 40 amp 12/24/48 voltage Maximum Power Point Tracking (MPPT) photovoltaic (PV) battery charge controller. Through the use of MPPT technology, Solar charger controller can increase charge current up to 30% or more compared to conventional controllers. Solar charger controller's sophisticated three stage charge control system can be configured to optimize charge parameters to precise battery requirements. The unit is fully protected against voltage transients, over temperature, over current, reverse battery and reverse PV connections. An automatic current limit feature allows use of the full 40 amp capability without worrying about overload from excessive current, voltage or amp-hour based load control.

Series pass Pulse Width Modulation (PWM) charge voltage control combined with a multistage charge control algorithm leads to superior charging and enhanced battery performance. The filtered PWM power control system uses highly efficient and reliable power MOSFET transistors. The MOSFET's are turned on and off at high frequency to precisely control charge voltage and MPPT.

Fully automatic temperature compensation of charge voltage is available to further improve charge control and battery performance. The optional battery temperature sensor is built for long term reliability. The sensor element is environmentally sealed and encapsulated into a plastic lug which adheres to directly to the battery terminal and by RJ11 port connect with the unit, And the Solar charger controller also includes an isolated RS232 port for connection to a PC computer for data logging and system monitoring.

The Solar charger controller can easily install in parallel connection of output, so it also suitable for large system current application condition.

1.2 Features

- ◆ A DC Load output port
- ◆ An optional battery temperature sensor ensures precise battery charging
- ◆ LED displays to indicate the status of charge
- ◆ Lightning protection
- ◆ Reverse current at night
- ◆ Three-stage battery charging (bulk, absorption, and float) with optional temperature compensation
- ◆ Automatic overload protection
- ◆ Microprocessor controlled
- ◆ Silent, pulse width modulated (PWM), high efficiency operation

1.3 Maximum setpoint voltage limit

Very cold batteries combined with high charge voltage setpoints can produce voltages high enough to disrupt or damage other equipment connected to the battery. To minimize possible damage a maximum voltage setpoint limit feature is provided. The factory defaults can be adjustable using software. Regardless of what setpoint values result from temperature compensation, the Solar charger controller will never attempt to apply a charge voltage greater than the maximum voltage setpoint limit value.

1.4 Temperature and output power

Over temperature protection is provided to protect the unit from damage due to high output power at high ambient temperatures. When mounted vertically as described in the installation section, the unit can deliver full output in a temperature of up to 40°C, and the unit will de-rate output in 40 - 60°C. While operating in charge mode, the controller will decrease the charge current to reduce the transistor temperature and the green led will be blinking green, reducing average power delivery to within safe limits. During thermal shutdown the charge status indicator will display an “off” condition. Over temperature shutdown occurs when the ambient temperature reaches 60°C.

1.5 Maximum power point tracking (MPPT)

MPPT and associated current boost operation is fully automatic and will function whenever sufficient PV voltage and current are available. The percent increase in output charge current relative to PV current is variable, and will change with operating conditions. When conditions are such that insufficient PV power is available to produce an increase in output current, the unit will stop its internal DC-DC power conversion and operate as a series pass PWM controller with very low forward voltage drop.

The principal operating conditions which affect current boost performance are PV array temperature and battery voltage. At constant solar intensity available PV power changes with PV temperature. A PV array's power vs. temperature characteristic is such that a cool PV array can produce a higher voltage and more power, than a hot PV array. When PV voltage is sufficiently high for MPPT to operate, a constant power output is delivered to the battery. Since output power is constant while MPPT is operating, a decrease in battery voltage produces corresponding increase in charge current. This means that the greatest current increase occurs with a combination of cool ambient temperature and low battery voltage. The unit delivers the greatest charge current increase when you need it most, in cold weather with a discharged battery. Additionally, anything that can be done to lower PV array temperature will also lead to increased charge current by increasing PV power production. In cool/comfortable temperatures and typical battery states of charge, most systems see about 10 – 20% increase. Charge current increase can go to zero in hot temperatures, whereas charge current increase can easily exceed 30% with a discharged battery and freezing temperatures.

1.6 How MPPT works

A PV module is a constant current type device. As shown on a typical PV module voltage vs. current curve, current remains relatively constant over a wide range of voltage. A typical 75 watt module is specified to deliver 4.45 amps @ 17 volts @ 25 C cell temperature. Conventional PV controllers essentially connect the PV array directly to the battery when battery is discharged. When a 75 watt module is connected directly to a battery charging at 12 volts, the module still provides approximately the same current. But, because output voltage is now at 12 volts rather than 17 volts, module power production is artificially limited and the 75W module only delivers 53 watts. This wastes 22 watts of available power.

Solar charger controller's MPPT technology operates in a very different fashion. Under these conditions Solar charger controller calculates the maximum power voltage (V) at which the PV module delivers maximum power, in this case 17 volts. It then MPPT operates the module 17 volts which extracts maximum available power from the module. Solar charger controller continually recalculates the maximum power voltage as operating conditions change. Input power from the maximum power tracking controller, in this case 75 watts, feeds a switching type power converter which reduces the 17 volt input to battery voltage at the output. The full 75 watts which is now being delivered at 12 volts would produce a current of 6.25 amps. A charge current increase of 1.8 amps or 40% is achieved by converting the 22 watts that would have been wasted into useable charge current. Note that this example assumes 100% efficiency to illustrate the principal of operation. In actual operation, boost will be somewhat less.

1.7 Over voltage / reverse polarity protection

Solar charger controller is fully protected against reverse polarity and high voltage transients for both the PV and the battery connections. If the battery is connected reverse polarity, Solar charger controller will be protected by inner fuse and fuse will be open. If the PV array is connected reverse polarity the charge control system will not turn on.

1.8 Electrostatic handling precautions

All electronic circuits may be damaged by static electricity. To minimize the likelihood of electrostatic damage, discharge yourself by touching a water faucet or other electrical ground prior to handling the unit and avoid touching components on the circuit boards. The risk of electrostatic damage is highest when relative humidity is below 40%.

1.9 Solar charger controller setup

1.9.1 Factory default settings

Table 1 – 1: Factory shipping settings

Basic settings	
Charge mode	3 stage
Absorption voltage	14.4/28.8/57.6V
Bulk voltage	14.6/29.2/58.4V
Float voltage	13.4/26.8/53.6V
Equalize	14.0/28.0/56.0V

1.10 Three stage charge control

Solar charger controller is typically configured for a three stage charging process, Bulk, Absorption and Float. The three stage charge process provides a somewhat higher charge voltage to charge the battery quickly and safely. Once the battery is fully charged a somewhat lower voltage is applied maintain the battery in a fully charged state without excessive water loss. The three stage charge process charges the battery as quickly as possible while minimizing battery water loss and maintenance.

Figure 1 – 1: Bulk charge curve

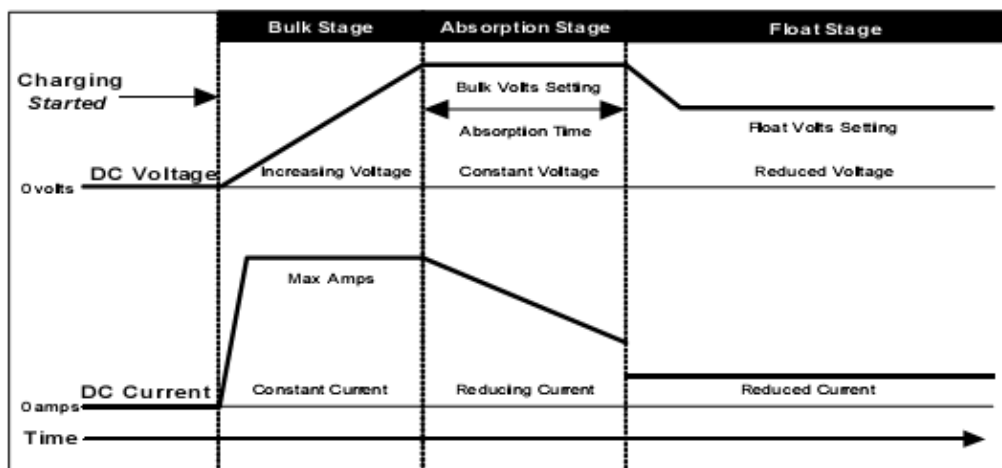

1.10.1 Bulk charge

When charge starts the Solar charger controller attempts to apply the bulk charge voltage to the battery. The system will switch to Bulk charge if the battery is sufficiently discharged and/or insufficient charge current is available to drive the battery up to the bulk voltage setpoint. During the Bulk charge stage the unit delivers as much charge current as possible to rapidly recharge the battery. Once the charge control system enters Absorption or Float, the unit will again switch to Bulk charge if battery voltage drops below the present charge voltage

setpoint.

1.10.2 Absorption charge

During this stage, the unit changes to a constant voltage mode where the absorption voltage is applied to the battery. When charge current decreases to the float transition current setting, the battery is fully charged and the unit switches to the float stage.

1.10.3 Float charge

During this stage, the float voltage is applied to the battery to maintain it in a fully charged state. When battery voltage drops below the float setting for a cumulative period, a new bulk cycle will be triggered.

1.11 Battery temperature sensor (BTS)

The charge voltage required by batteries changes with battery temperature. Temperature compensation of charge voltage enhances battery performance and life, and decreases battery maintenance. Automatic temperature compensation can be provided through use of the optional battery temperature sensor. The following table describes approximately how much the voltage may vary depending on the temperature of the batteries.

1.12 Equalization charge

Equalize charging is a special mode of battery charging. During use, the battery's cells can become unequal in the voltage and current they can deliver. This is due to a buildup of sulfate on the plates as well as stratified electrolyte. Sulfate prevents the cells from receiving or delivering full power. If the sulfate is left on the plates, it will harden, and permanently reduce the battery's capacity. Stratification separates the heavier acid from the water, and the concentrated acid remains at the lower portion of the plates, eventually corroding them. Equalizing the batteries every month or two (depending on usage) prolongs the life of the batteries and provides better battery performance.

To set the Equalize Charge:

- ◆ Remove all DC loads connected to the batteries.
- ◆ Remove all battery vent caps.
- ◆ Check the battery water level, it should be just over the top of the plates (do not over fill). Use only distilled water for filling batteries.
- ◆ Set the BATTERY TYPE SELECTOR switch to position "0" or "1"(position "1" is reserved).
- ◆ Reset the BATTERY TYPE SELECTOR potentiometer to the appropriate setting for the system batteries when the Equalize charge has completed.

1.12.1 Photovoltaic charge and load controller

The Solar charger controller can operate as a PV charge controller. the solar charger controller can regulate up to 40amps of continuous photovoltaic (PV) array current at 12/24/48 volts DC for charging batteries. at the same time the Solar charger controller can provide the maximum 15Amp current to DC load ,but the rating 40Amp current is shared battery with DC load.

When the PV voltage is lower, the battery will provide the power to the DC load , In the load control condition, the Solar charger controller controls when to remove load from the system when an over-discharge or over-load situation occurs. The Solar charger controller uses the software setpoints to determine when to disconnect or reconnect loads depending on battery voltage. Solar charger controller prevents damage to the battery from over-discharge during periods of poor weather or excessive loads. The solar charger controller can charge the batteries when in this function.

Figure 1 – 2: PV charge and load controller



1.12.2 Automatic PV array night disconnect

When using PV Charge Control mode, the PV array is automatically disconnected from the battery at night to prevent reverse leakage of power and protect PV.

1.12.3 Solar charger controller load control

The Solar charger controller can operate as a low voltage disconnect (LVD) for DC loads to prevent over-discharge to batteries during periods of poor charging or excessive loads. The Solar charger controller uses the software setpoints to determine when to disconnect or reconnect loads depending on battery voltage.

1.12.4 Low voltage disconnect

When configured as a load controller, the Solar charger controller will disconnect the load from the batteries when it reaches the LVD setting. There will be a 1-minute delay after the voltage drops below the Low Voltage Disconnect (LVD) setting before the controller actually disconnects the load.

1.12.5 Low voltage reconnect

It can also provide automatic reconnection of the loads at the low voltage reconnect (LVR) setting. Reconnection of the load is allowed once the battery voltage has exceeded the low voltage reconnect (LVR) setting. Loads are either automatically when battery voltage exceeds the low voltage reconnect (LVR) setting for 1 minutes.

Figure 1 – 3: Load controller



Important: When using the Solar charger controller load control:

- ◆ Do not temperature-compensate these settings.
- ◆ Do not install the optional battery temperature compensation sensor.

1.13 Optional accessories

The follow accessories can be purchased for use with the Solar charger controller:

Battery Temperature Sensor (BTS): The BTS is installed on the side of the battery and attaches to RS232 port inside the Solar charger controller. It provides accurate sensing of the battery temperature and uses this reading to control charging. Using this accessory can extend battery life and improve overall charging.

2. Installation

2.1 Pre-Installation

The instructions that follow are applicable to the typical installation. For special applications, consult a qualified electrician or your Certified Dealer. Installation procedures will vary according to your specific application.

- ✧ Important: Installations should meet all local codes and standards. Installations of this equipment should only be performed by skilled personnel such as qualified electricians and Certified Renewable Energy (RE) System Installers.

2.2 Removing the topcover

1. Access the inside of the solar charger controller by removing the four screws M3*6 on the cover of the unit.
2. Remove the top cover of Solar charger controller.

Figure 1 – 4: Removing the topcover



Remove these screws M3*6 (*4) from the topcover to access the heatsink of controller



Remove the Topcover

2.3 Mounting the Solar charger controller

The Solar charger controller is designed for indoor mounting. Care should be taken in selecting a location and when mounting the enclosure. Avoid mounting it in direct sunlight to prevent heating of the enclosure. The enclosure should be mounted vertically on a wall. In outdoor installations, the Solar charge controller must be installed in a rainproof enclosure to eliminate exposure to rain, mist or water-spray.

✧ **Caution:** Damage to Solar charge Controller, Install the Solar charge controller in a dry, protected location away from sources of high temperature, moisture, and vibration. Exposure to saltwater is particularly destructive. Corrosion is not covered by the warranty.

2.3.1 Mount the Solar charge controller

1. Place the controller on the desired mounting surface and mark the location of the keyhole slots on the wall.
2. Move the controller out of the way, and secure two mounting screws in the locations marked. Leave the screw heads backed out approximately 1/4inch (6 mm) or less.
3. Place the controller onto the screws and pull it down into the keyhole slots.
4. Then insert the two screws provided to secure the enclosure onto the wall.

✧ **Warning:** Explosion/Corrosion Hazard and don't mount solar charger controller on the flammable wall (for example: wooden wall and so on).

Do not locate the Solar charge controller in a sealed compartment with the batteries. Batteries can vent hydrogen-sulfide gas, which is corrosive to electronic equipment. Batteries also generate hydrogen and oxygen gas that can explode when exposed to a spark.

Figure 1 – 5: Mounting the Solar charge controller

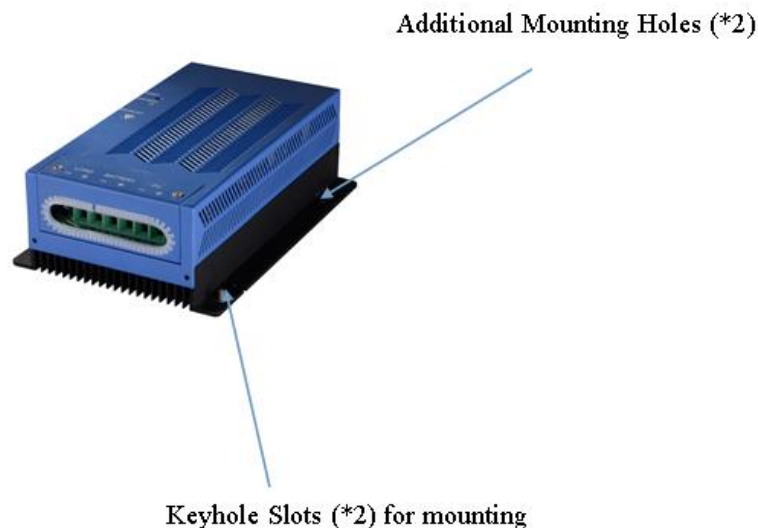

2.4 Configuring the Solar charge controller

Before making any wiring connections to the Solar charge controller, it must be configured for the desired mode of operation. The following sections describe the how to configure the unit for the desired application and function.

2.4.1 Battery type selector can apply different charger method

The battery type selector is a 10 position rotary switch used to set the Solar charger controller for the proper float and bulk voltage levels. These levels are selected depending on the type of batteries used. Refer to the table below for the charge voltages in the various switch positions. Consult the battery manufacturer for optimum battery voltage charging settings.

Figure 1 – 6: Battery type selector (B.SEL)

BAT.SELECT



Table 1 – 2: Battery type selector switch settings

Switch Position	Description	12-volt		24-volt		24-volt		Charge Function	
		Float voltage (V)	Bulk/Equalize voltage (V)	Float voltage (V)	Bulk/Equalize voltage (V)	Float voltage (V)	Bulk/Equalize voltage (V)	Equalize charge rate	Equalize time
0	Equalize 1 - equalizes at a rate equal to the battery bank capacity (in amp hours) divided by 40.	13.2	*15	26.4	*30	52.8	*60	Max 40Amp	Depend on battery capacity
1	Equalize 2 -charges at a rate set by the BATTERY CHARGER RATE control.	13.2	*15.5	26.4	*31	52.8	*62	Battery Charger Rate Setting (manual)	Depend on battery capacity

2	Deep Cell Lead Acid 2	13.3	15	26.6	30	53.2	60	Provides an additional Float and Bulk settings for deep cycle, lead acid batteries. Refer to the battery manufacturer recommendation for Float and Bulk settings.
3	Not Specified	13.6	14.3	27.2	28.6	54.4	57.2	Provides an additional setting of Bulk and Float voltages.
4	Gel Cel 2	13.7	14.4	27.4	28.8	54.8	57.6	Recommended for gel cell batteries that specify high float voltages. Check with the battery manufacturer.
5	Gel Cell 1	13.5	14.1	27	28.2	54	56.4	Typical gel cell setting.
6	PcCa-lead Calcium	13.2	14.3	26.4	28.6	52.8	57.2	Use this setting for sealed type car batteries.
7	Deep Cycle Lead Acid 1 (Default Setting)	13.4	14.6	26.8	29.2	53.6	58.4	Factory setting for typical deep cycle lead acid batteries.
8	NiCad 1	14	16	28	32	56	64	Use for NiCad battery systems.
9	NiCad 2	14.5	16	29	32	58	64	Recommended for use with nickel iron batteries.

✧ Important:

1. Switch positions “0” and “1” are for monthly battery maintenance only. Return the switch to the appropriate position for the system’s batteries when Equalize charging has completed. NEVER EQUALIZE GEL BATTERIES! Use together with BATTERY CHARGER RATE potentiometer (position1) or BATTERY CAPACITY potentiometer (position 0).
2. Equalize voltages are displayed in the table with an asterisk (*) – Switch positions “0” and “1” only.
3. Switch position “7” is the default values as shipped from the factory.
4. Always refer to the battery manufacturer’s specifications for equalization.

2.5 Temperature compensation

For optimal battery charging, the Bulk and Float charge rates should be adjusted according to the temperature of the battery. When battery charging voltages are compensated based on temperature, the charge voltage will vary depending on the temperature around the batteries.

2.5.1 Temperature compensation based on battery type

The charge voltage required by batteries changes with battery temperature. Temperature compensation of charge voltage enhances battery performance and life, and decreases battery maintenance. Automatic temperature compensation can be provided through use of the optional battery temperature sensor. The following table describes approximately how much the voltage may vary depending on the temperature of the batteries. Temperature compensation is based on battery type-5mv /cell for lead acid type batteries and 2mv/cell for alkaline type batteries (NiCad or NiFe). The temperature compensation calculations are derived from the following table.

Table 1 – 3: Temperature compensation calculation

Battery Type	12 Vdc	24 Vdc	48 Vdc
Lead Acid	0.03 volts (30mv) /°C	0.06 volts (60mv) /°C	0.12 volts (120mv) /°C
NiCad	0.02 volts (20mv) /°C	0.04 volts (40mv) /°C	0.08 volts (80mv) /°C

2.5.2 Automatic battery temperature compensation

Temperature compensation can be accomplished automatically by using a Battery Temperature Sensor (BTS). The sensor attaches directly to the side of one of the batteries in the bank and provides precise battery temperature. See “Installing the Battery Temperature Sensor” for detailed instructions on how and where to install the BTS. If a BTS is installed, the charge controlling process will be automatically adjusted for the battery temperature. When using a BTS, set the Bulk and Float voltage for a battery at normal room temperature for 25 °C.

Table 1 – 4: Battery compensation coefficient

Temperature (around the BTS)		12 Vdc		24 Vdc		48 Vdc	
Celsius	Fahrenheit	Lead Acid (6 cells)	NiCad (10 cells)	Lead Acid (12 cells)	NiCad (20 cells)	Lead Acid (24 cells)	NiCad (40 cells)
60	140	-1.05	-0.7	-2.1	-1.4	-4.2	-2.8
55	131	-0.9	-0.6	-1.8	-1.2	-3.6	-2.4
50	122	-0.75	-0.5	-1.5	-1	-3.0	-2
45	113	-0.6	-0.4	-1.2	-0.8	-2.4	-1.6
40	104	-0.45	-0.3	-0.9	-0.6	-1.8	-1.2
35	95	-0.3	-0.2	-0.6	-0.4	-1.2	-0.8
30	86	-0.15	-0.1	-0.3	-0.2	-0.6	-0.4
25	77	0	0	0	0	0	0
20	68	0.15	0.1	0.3	0.2	0.6	0.4
15	59	0.3	0.2	0.6	0.4	1.2	0.8
10	50	0.45	0.3	0.9	0.6	1.8	1.2
5	41	0.6	0.4	1.2	0.8	2.4	1.6
0	32	0.75	0.5	1.5	1	3.0	2
-5	23	0.9	0.6	1.8	1.2	3.6	2.4
-10	14	1.05	0.7	2.1	1.4	4.2	2.8
-15	5	1.2	0.8	2.4	1.6	4.8	3.2
-20	-4	1.35	0.9	2.7	1.8	5.4	3.6
-25	-13	1.5	1	3	2	6	4
-30	-22	1.65	1.1	3.3	2.2	6.6	4.4
-35	-31	1.8	1.2	3.6	2.4	7.2	4.8
-40	-40	1.95	1.3	3.9	2.6	7.8	5.2

If using a BTS, when the battery temperature drops below 25 °C, the regulation voltage setting automatically increases. When the temperature rises above 25 °C the regulation battery voltage setting automatically decreases.

2.6 Grounding

The Solar charge controller is designed to work with grounded electrical systems. In solar charger controller

ground is not connected to input terminal and output terminal so customer can connect Ground to battery + or batter -. But don't connect battery terminal and PV output terminal with Ground at same time

Figure 1 – 7: Safety (Earth) ground

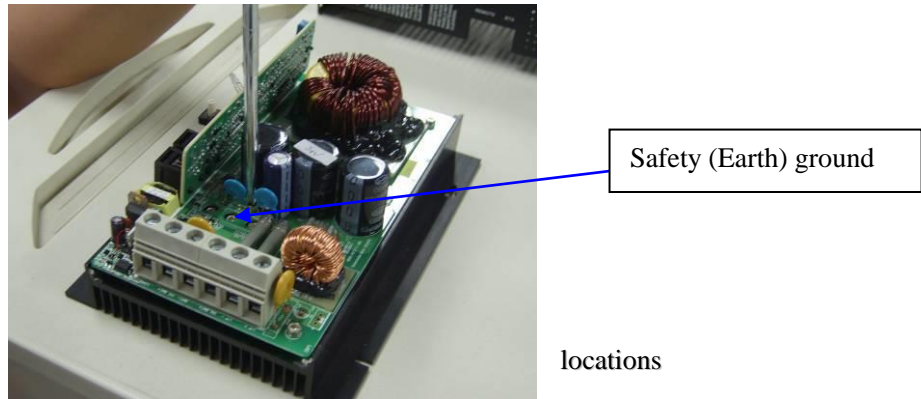

2.7 DC terminal connector

locations

Terminal connectors for DC wiring are located on the lower edge of the circuit board. Terminal Torque Requirements. Once the wires have been installed, torque the terminals as follows. Be careful not to over tighten.

Figure 1 – 8: DC terminal connector locations

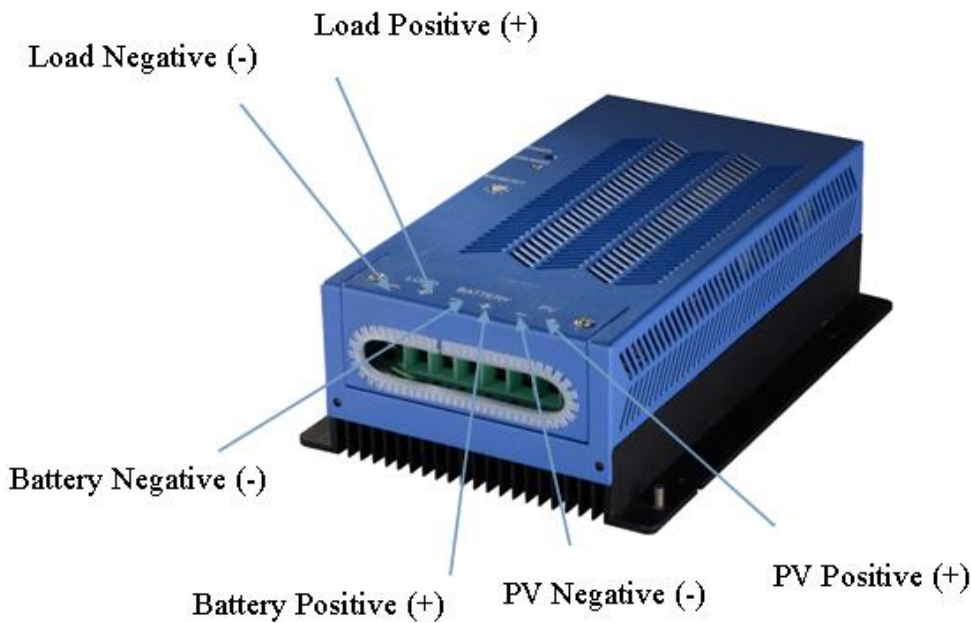

2.8 Wire Size and Over-current Protection Requirements

The wiring, over-current protection devices (fuses), and installation methods used must conform to all national

and local electrical code requirements. Wiring should be protected from physical damage with conduit or a strain relief clamp.

2.8.1 Current Rating

Solar charge controller is rated for a rating continuous current of 40 amps. Since PV outputs can vary due to the array size or sunlight striking it, the safe minimum wire size should be based on the maximum current ratings.

2.8.2 Surge Protection

Since PV arrays are often mounted on an elevated structure and thus are more susceptible to lightning strikes, protection from lightning-induced power surges and other transient power disturbances between the PV array and the Solar charge controller are strongly recommended. Because the Solar charger controller have wider input voltage range 15-55VDC.

2.8.3 Over-current Protection

If the controller detects an overload, it will automatically resets the over current protection system every 6 minutes. If the default is still present, the controller will shut off and wait another 6 minutes. This will occur continuously until the problem is corrected.

Table 1 – 5: Minimum wire size

Controller	Minimum Wire Size
12/24/48 VDC	#8AWG

2.9 PV Charge And Load Control Mode Wiring

The procedure below is illustrated in Figure 1 – 9.

❖ **WARNING: Shock Hazard**

PV arrays generate voltage whenever light strikes the surface of the array. Before connecting the Solar charge controller, cover or disconnect the array to prevent any current from being generated.

1. Connect the PV array's positive (+) output to the terminal marked PV positive (+) on the Solar charge controller and tighten the screw.
2. Connect the PV array's negative (-) output to the terminal marked PV negative (-) on the Solar charge controller and tighten the screw.
3. Connect the terminal marked battery negative (-) on the Solar charge controller to the negative (-) battery terminal and tighten the screw.
4. Connect the terminal marked battery positive (+) on the Solar charge controller to the positive (+) battery terminal and tighten the screw.
5. Connect the terminal marked load negative (-) on the Solar charge controller to the negative (-) load terminal and tighten the screw.
6. Connect the terminal marked load positive (+) on the Solar charger controller to the positive (+) battery terminal and tighten the screw.
7. Connect a cable from the controller's other terminal marked load negative (-) to the negative terminal of your DC load and tighten the screw.
8. Connect a cable from the controller's other terminal marked load positive (+) to the positive terminal of your DC load and tighten the screw.

Figure 1 – 9: PV charge control mode wiring

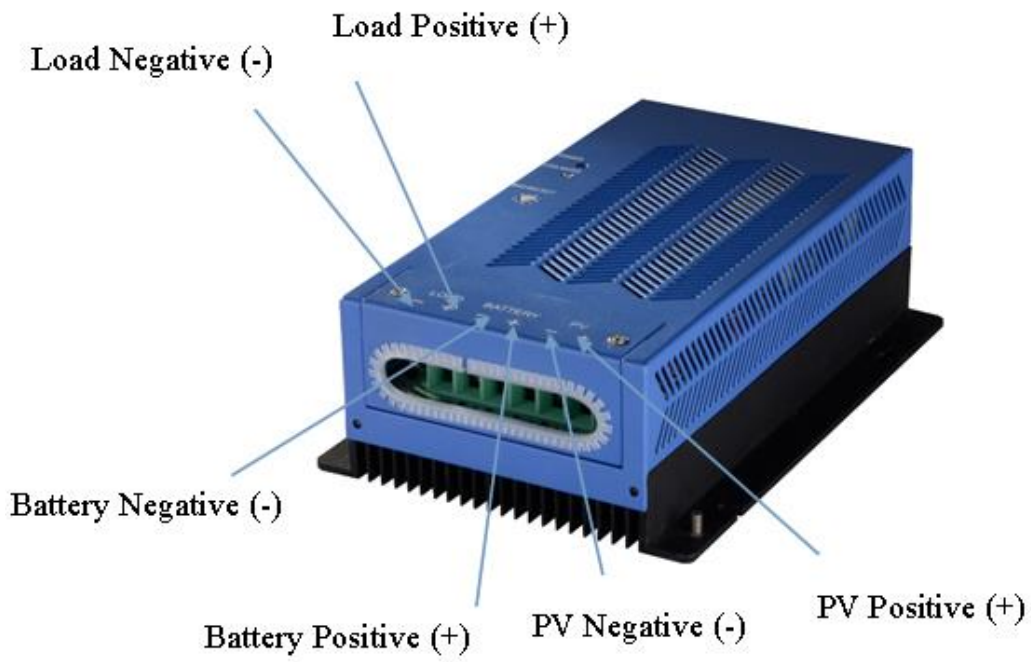

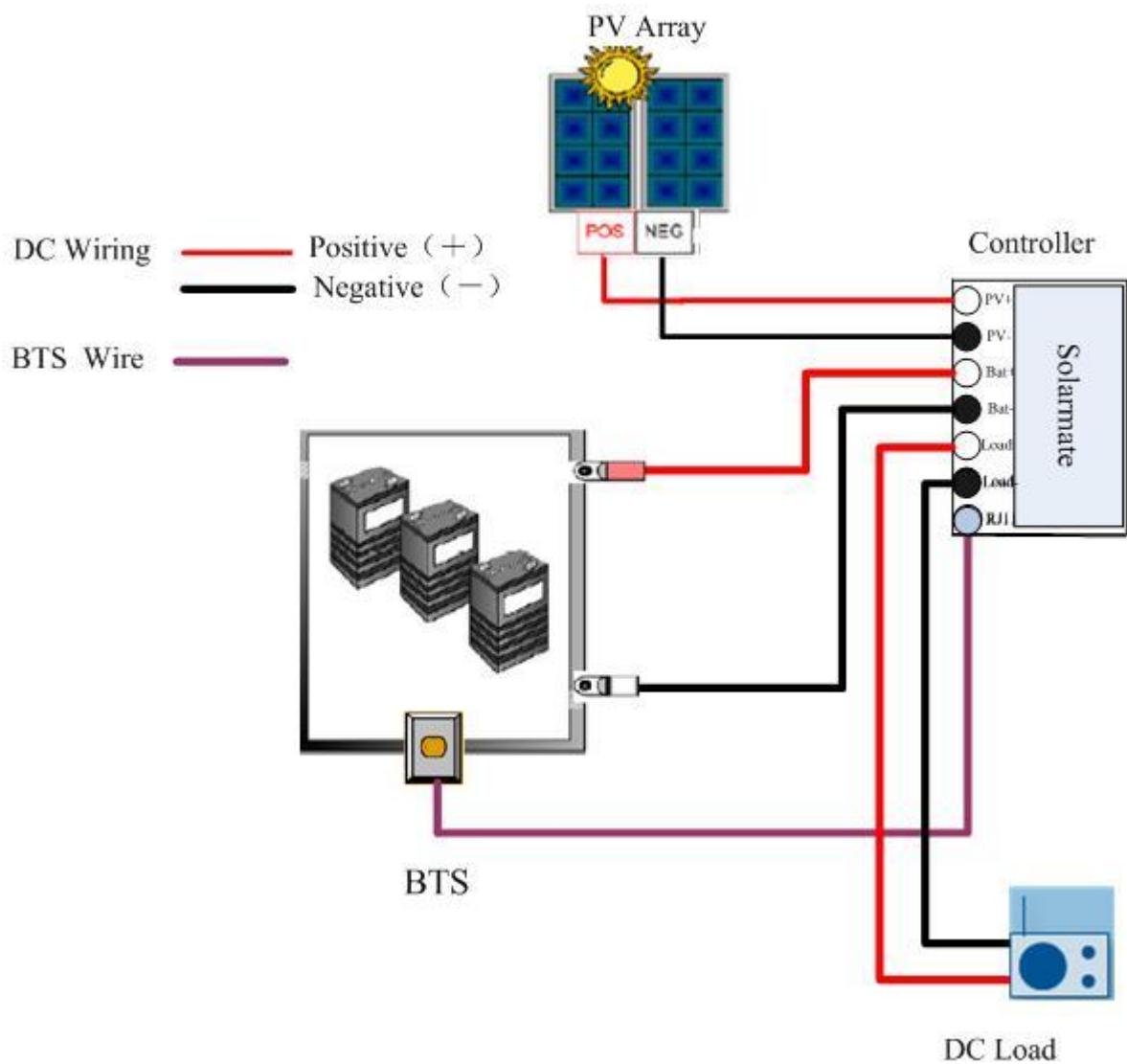

2.10 Easily install in parallel connection

In order to get more than 40A charge current, Output of solar charger controller can be connected in parallel. For example, connecting 2 Solar charger controller in parallel can get 80A charger current, and connecting 3 Solar charger controller in parallel can get 120A charger current.

Figure 1 – 10: Parallel connection

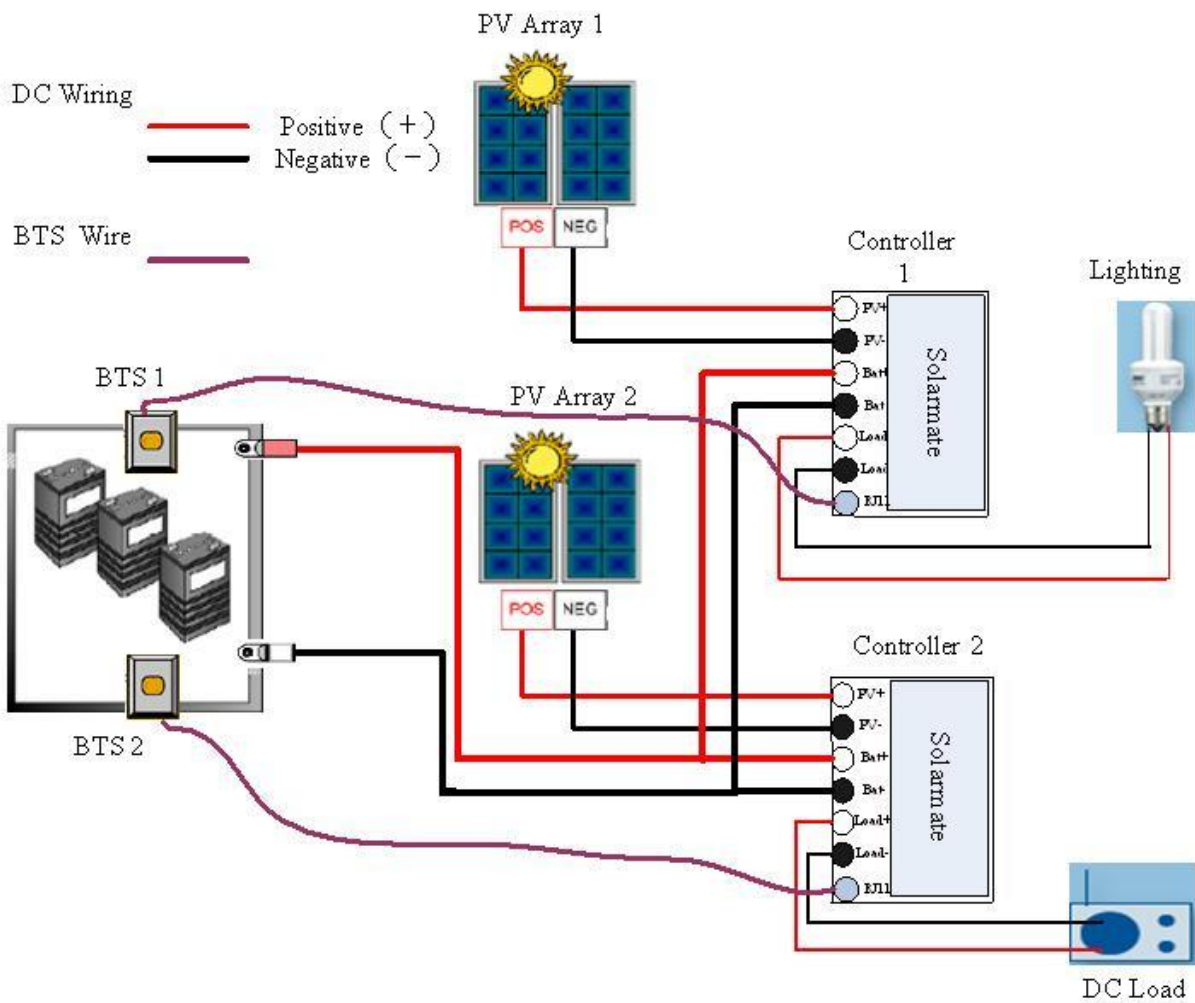

2.11 Battery type selector

Please see 2.5.1 section, which you find the different one of 10 positions stand for the different battery type specified. You can select the Solar charger controller for the proper float and bulk voltage levels. These levels are selected depending on the type of batteries used. Refer to the table below for the charge voltages in the various switch positions. Consult the battery manufacturer for optimum battery voltage charging settings.

Figure 1 – 11: battery type selector

Please use truss screwdriver to select proper position



2.12 Installing Optional Accessories

The following sections describe how to install the optional accessories available for the Solar charge controller.

To install the Battery temperature sensor (BTS)

1. Install the BTS on the side of the battery below the electrolyte level. It is best to place the sensor between batteries and place the batteries in an insulated box to reduce the influence of the ambient temperature outside the battery enclosure.
2. Insert the RJ-11 plug on the other end of the BTS into the BTS Port on the Solar charge controller.

Figure 1 – 12: Install BTS



RJ-11 Port

Accept BTS to the side of the battery

2.13 Reinstalling the Faceplate

To reinstall the faceplate on the Solar charge controller:

1. Align topcover so that two screw holes in the corners line up.
2. Insert the screws into the screw holes and tighten.

Figure 1 – 13: Reinstalling the faceplate



Align these screw holes, replace the screw to secure the top cover

3. Operation

Chapter 3 contains information about the operation of Solar charge controller.

3.1 Basic Operation

The Solar charge controller has one blue and multicolor LED status indicator, one battery type selector.

Figure 1 – 14: LED status indicator



3.2 LED Status Indicator

The Solar charger controller has one multicolor LED and one green LED to indicate the operating status of the controller. The green LED indicates whether the charging source is functioning properly when it display solid green or the type of the fault when it flash. And the multi color LED indicates the particular operating mode and the batteries capacity level.

3.2.1 Charge control indications

	LED1			LED2			Description	Operation mode
	State	On	Off	State	On	Off		
1	Solid green	all	0	Solid red	all	0	Charge ON(PV>BV), BAT<LVD	Normal
2	Solid green	all	0	Solid orange	all	0	Charge ON(PV>BV), LVD<BAT<LVR	
3	Solid green	all	0	Solid green	all	0	Charge ON(PV>BV), BAT>LVR	
4	Solid green	all	0	Blink red	1s	1s	Charge ON(PV>BV), BAT<LVD	Derated
5	Solid green	all	0	Blink orange	1s	1s	Charge ON(PV>BV), LVD<BAT<LVR	
6	Solid green	all	0	Blink green	1s	1s	Charge ON(PV>BV),	

							BAT>LVR	
7	Off	0	all	Blink orange	1s	6s	BAT under voltage	Fault
8	Blink green	3s	6s	Off	0	all	DC load over current or dc load voltage out of the range	
9	Blink green	2s	6s	Off	0	all	Over Temperature	
10	Blink green	1s	1s	Blink red	1s	1s	PV over voltage	
11	Blink green	1s	1s	Blink orange	1s	1s	PV under voltage	
12	Blink green	1s	6s	Blink red	0	all	BAT over voltage	
13	Blink green	all	0	Blink red	0	all	when Solar charger controller starts, wait for 3s; if the start time is over 3s, then mean that the BAT voltage is out of the range	

Table 1 – 6: The LED indicators

NOTE:

When the solar charger controller is charging, the green LED will be solid green.

1) Low voltage disconnect

When connected with DC load, if voltage remains below the Low Voltage Disconnect setting, the controller will disconnect after a 1-minute delay period. And the controller waits until the voltage rises above the Low Voltage Recovery setting.

2) Over voltage of load

If the controller detects an over voltage of load, it will disconnect the load.

3) Over temperature

The temperature of the controller's transistors is continuously monitored. This protects the charge controller from damage in high temperature environments if excessive temperatures are detected.

while operating in charge mode, the controller will decrease the charge current to reduce the transistor temperature and the green led will be solid green. If the Solar charger controller connected with DC load, the load is disconnected before the transistors reach an excessive temperature and the green LED flashes. Once the temperature has dropped, the loads are reconnected.

4) Over current of the load

If the controller detects an overload or short circuit of the load, it will automatically resets the over current protection system every 6 minutes. If the default is still present, the controller will shut off and wait another 6 minutes. This will occur continuously until the problem is corrected.

4. Troubleshooting

Table 1 – 7: Troubleshooting list

Symptom	Probable cause	Items to examine or correct
Completely dead, no display	No battery power	Battery disconnected, overly discharged, or connected reverse dead, no display polarity. Battery powers the system, not PV.
Unit will not turn on (charge status LED off), Display if attached is OK	PV disconnected PV reverse polarity PV- connected to BAT- external to controller	PV disconnected PV must supply at least 0.25Amp at 3V more than battery voltage to begin charge. PV reverse polarity, Reverse polarity PV will cause heat sink to heat. PV- & BAT- must be separate for proper operation. PV- must receive earth ground via shunts inside the Solar charger controller which internally connect PV- to BAT-. External connection prevents proper operation of internal shunts and current measurement system. Battery voltage is determined automatically when the unit first receives power. Voltage must be less than 30Vdc for 12Vdc battery, or greater than 30Vdc for 24Vdc battery. Apply battery quickly and crisply.
Charge status LED on, but no output charge current	Battery voltage greater than charge voltage setpoint Battery voltage too low	This is normal operation. Output is off due to high battery voltage which may be caused by other charging systems. Battery voltage must be at least 9Vdc for the unit to operate.
Charge current is lower than expected, PV current may be low as well	Battery is highly charged Worn out PV modules Low insolation PV- connected to BAT- Nominal PV voltage has changed from 24Vdc to 12Vdc	Normal operation, current is reduced if battery voltage is at setpoint Replace, or use as is. Atmospheric haze, PV's dirty, sun low on horizon, etc. PV- & BAT- must be separate for proper operation. PV- must receive earth ground via shunts inside the Solar charger controller which internally connect PV- to BAT-. External connection prevents proper operation of internal shunts and current measurement system. If PV voltage is changed from 24Vdc to 12Vdc, battery and PV power must be removed momentarily to reboot unit and load initial 12Vdc PV control values. Unit considers PV's to 24Vdc if PV voltage ever goes above 30Vdc.
Charge OFF at high temperature	System temporarily shuts down due	Improve ventilation or reduce PV

	to high heat sink temperature	power. Sufficient ventilation to prevent over temperature shut down
--	-------------------------------	---

5. Specifications

Specifications provide the specifications for the Solar charge controller.

5.1 Specifications

Table 1 – 8: Electrical specification

Rated Voltage	MPPT 12/24/48Vdc		
Rated charge current (Include load current)	40/60Amp		
Load current	15Amp		
Input voltage range	15-100Vdc		
Max. PV open circuit array voltage	100Vdc		
Overload protection (DC load)	2.0 * Inom > 5s 1.5 * Inom > 20s 1.25 * Inom temperature controlled		
Typical idle consumption	At idle < 10mA		
Bulk charge (Default)	14.6Vdc	29.2Vdc	29.2Vdc
Floating charge (Default)	13.4Vdc	26.8Vdc	53.6Vdc
Equalization charge (Default)	14.0Vdc	28.0Vdc	56.0Vdc
Over charge disconnection	14.8Vdc	29.6Vdc	59.2Vdc
Over charge recovery	13.6Vdc	27.2Vdc	54.4Vdc
Over discharge disconnection	10.8Vdc (default)	21.6Vdc (default)	43.2Vdc (default)
Over discharge reconnection	12.3Vdc	24.6Vdc	49.2Vdc
Temperature compensation	-13.2mV/°C	-26.4mV/°C	-52.8mV/°C
Lead acid battery settings	Adjustable		
NiCad battery settings	Adjustable		
Load control mode	1. Low Voltage Reconnect (LVR): Adjustable 2. Low Voltage Disconnect (LVD): Automatic disconnection 3. Reconnection: Includes warning flash before disconnect & reconnection		
Low voltage reconnect	12.0-14.0Vdc	24.0-28.0Vdc	48.0-56.0Vdc
Low voltage disconnect	10.5-12.5Vdc	21.0-25.0Vdc	42.0-50.0Vdc
Ambient temperature	0-40°C (Full load) 40-60°C (De-Rating)		
Altitude	Operating 5000 m, Non-Operating 16000 m		
Protection class	IP21		
Battery temperature sensor	BTS - Optional Remote battery temperature sensor for increased charging precision		
Terminal size (fine/single wire)	#8 AWG		

5.2 Environmental

5.2.1 Temperature

5.2.1.1 Operating Temperature

0°C to 40°C (40°C to 60°C (de-rating))

5.2.1.2 Transit Temperature

25°C to +70°C

5.2.1.3 Storage Temperature

-25°C to +70°C

5.3 Safety and EMC

5.3.2 European market: CE

5.3.2.1 Compliant with EN 60335-1

5.3.2.2 Compliant with EN61000-6-1:2001

5.3.2.3 Compliant with EN61000-6-3:2001

5.4 Humidity

5.4.1 Operating Humidity

20 to 80% relative humidity (non-condensing)

5.4.2 Non-Operating Humidity

5 to 95% relative humidity, 38.7°C maximum wet bulb temperature with no cosmetic damage.

5.5 Mechanical features

Table 1 – 9: Mechanical specification

Items	Specification
Dimension (H x W x D)	Depth: ≤ 202 mm Height: ≤ 66 mm Width: ≤ 140 mm
Unit Weight	1.4Kg
Warranty	2 years
Mounting	Vertical wall mount - indoor only
Cooling	Natural cooling

5.6 Detailed dimension drawing

Figure 1 – 15: Solar charger controller dimension drawing

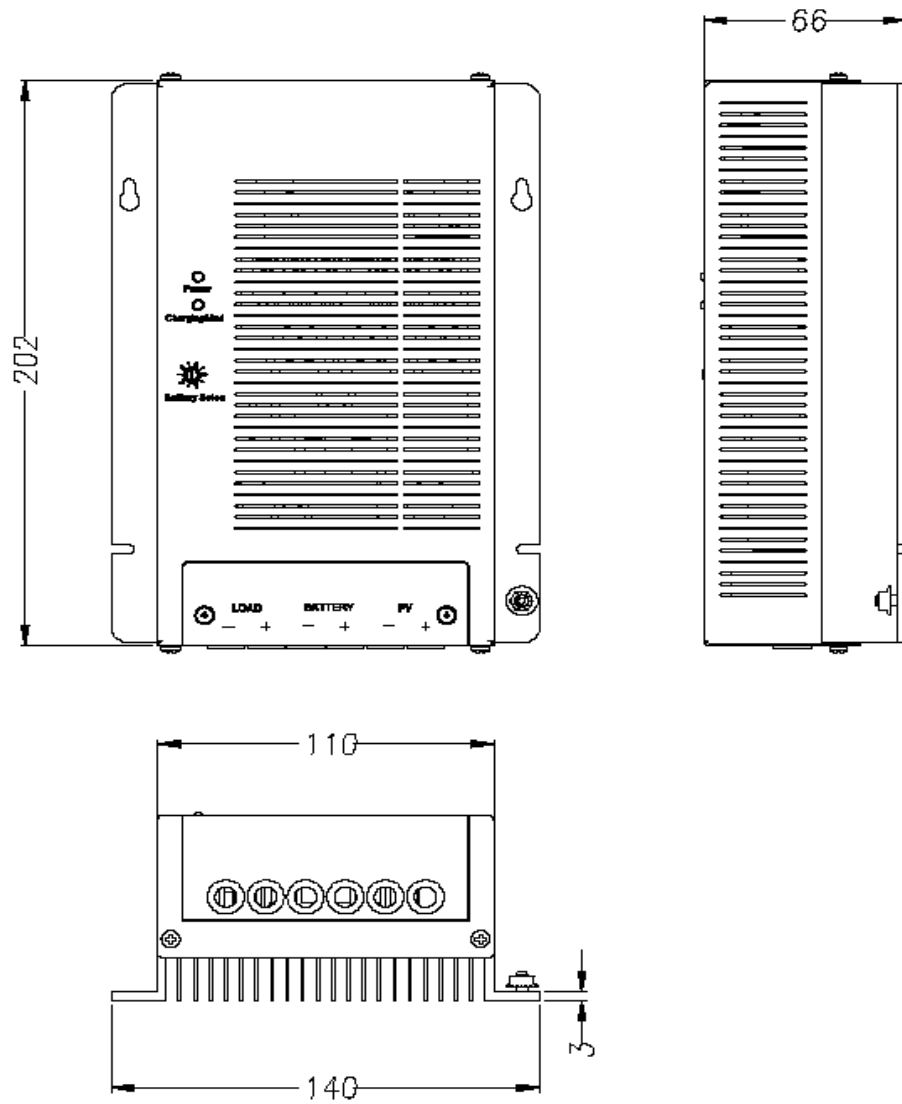

6. Batteries

6.1 Battery Types

Batteries come in different sizes, types, amp-hour capacity, voltages and chemistries. Here are a few guidelines that will help in battery selection, and ensure that the batteries are properly maintained. The best source of the most appropriate settings for the Solar charger controller will be from the manufacturer or supplier of the batteries.

6.2 Automotive Batteries

Automotive and truck batteries are designed for high cranking power – not deep-cycling. Do not use them unless no other battery type is available. They simply will not last long in a cycling application.

6.3 Maintenance-Free Batteries

This type of battery is often sold as a RV or marine battery, but is rarely appropriate for use with a PV system. They typically have an additional reserve of electrolyte, but are vented. This is not the same as a sealed battery.

6.4 Deep-Cycle Batteries

Best suited for use with PV systems, this type of battery is designed to be more deeply discharged before being recharged. Deep-cycle batteries are available in many sizes and types. The most common is the vented liquid electrolyte battery. Vented batteries usually have battery caps. The caps may appear to be sealed, but are not. The caps should be removed periodically to check the level of electrolyte. When a cell is low, distilled water should be added after the battery is fully charged. If the level is extremely low, add only enough distilled water to cover the plates before recharging. The electrolyte volume increases during the charging process and the battery will overflow if it is filled all of the way up before recharging. Use only distilled water because impurities will reduce battery performance. A popular and inexpensive deep-cycle battery is the “golf cart” battery. It is a 6-volt design, typically rated at 220amp-hours. RV and marine deep-cycle batteries are also popular for small systems. They are usually referred to as Group 24 or Group 27 batteries and are rated at 80 to 100 amp-hours at 12volts. Many larger systems use L16 batteries, which are usually rated at 350amp-hours at 6-volts each. They are 17 inches high and weigh about 130pounds. 8D batteries are available with either cranking or deep-cycle construction. Purchase only the deep-cycle version. The 8D is typically rated at 220 amp hours at 12 volts.

6.5 Sealed Batteries

Another type of battery construction is the sealed gel cell. They do not use battery caps. The electrolyte is in the form of a gel rather than a liquid, which allows the batteries to be mounted in any position. The advantages are no maintenance, long life (800 cycles claimed) and low self-discharge. Absorbed glass mat (AGM) electrolyte batteries are also acceptable. Their electrolyte is contained in mats between the battery plates. Sealed batteries reduce the maintenance requirements for the system and are good for remote applications. They are much more sensitive to the charging process and can be ruined in as little as a day of overcharging.

6.6 Battery Sizing

Batteries are the fuel tank of the system. The larger the batteries, the longer the system can operate before recharging is necessary. An undersized battery bank results in short battery life and disappointing system performance. To determine the proper battery bank size, compute the number of amp-hours that will be used between charging cycles. Once the required amp hours are known, size the batteries at approximately twice this amount. Doubling the expected amp-hour usage ensures that the batteries will not be overly discharged and will extend battery life.

6.7 Equalization Charging

Approximately every month, some batteries may need to be “equalized.” Since the individual cells of the battery are not identical, some cells may not be fully charged when the charging process is completed. If the batteries have been left in a discharged condition for long periods of time, the plates will have sulfates on them from the electrolyte. If the sulfate remains on the plates for an extended period of time, it will harden and seal off a percentage of the plate area, reducing the capacity of the battery. By equalizing the batteries before the sulfate

hardens, the sulfate is removed from the plates. Batteries with liquid electrolyte may become stratified. Stratification concentrates the sulfuric acid into the bottom of the cell while the top becomes diluted. This corrodes the lower portion of the plates, reducing battery life. Mixing of the electrolyte by the formation of gas bubbles during the equalization process reduces stratification. Two methods can be used to determine if a battery needs to be equalized. If possible, measure the voltage of each individual cell while the battery is at rest (not being charged or discharged). A variation of 0.05 volts between cells indicates an imbalance exists. If the battery construction prevents measurement of the individual cell voltages, use a hydrometer. A variation of 0.020 in the specific gravity between cells is considered significant. Both conditions can be corrected by an equalization charge. A proper equalization charge will not damage a vented, liquid electrolyte type battery. It may, however, cause significant electrolyte usage and require that the battery be refilled with distilled water to the correct level. This may be a problem with unattended systems in remote areas which do not receive regular maintenance. Consult the battery manufacturer for their recommendations.

6.8 Equalization Setpoints (Non-Sealed Batteries Only)

Battery Type	Bulk Volts	Float Volts	Equalizing Charge
Default Settings	14.0 Vdc	13.5 Vdc	Disabled
Sealed Gel Lead Acid Battery	14.1 Vdc	13.6 Vdc	Non recommended. Consult Battery manufacturer.
AGM Lead Acid Battery	14.4 Vdc	13.4 Vdc	Charge to 15.5Vdc or per manufacturer.
Maintenance-Free RV/Marine	14.4 Vdc	13.4 Vdc	Limited appropriateness if water level can be checked.
Deep-Cycle, Liquid Electrolyte Lead Antimony Battery	14.6 Vdc	13.4 Vdc	Charge to 15.5Vdc or per Antimony Battery battery manufacturer.
NiCad or NiFe Alkaline A Battery	16.0 Vdc	14.5 Vdc	Not recommended Consult battery manufacturer

Table 1 – 10: Battery equalization