



Axial-flow full cone nozzles

Series 490 / 491

NEW Patent pending



Non-clogging nozzle design. Stable spray angle. Particularly even liquid distribution.

Applications:

Cleaning and washing processes, surface spraying, container cleaning, foam precipitation, degassing of liquids.



Series 490



Series 491

Series 490/491 represents a new generation within the axial-flow full cone nozzles product group. These nozzles were developed using state-of-the-art design and simulation methods (CFD).

Nozzles of series 490/491 replace series 460/461 which are still available on request.

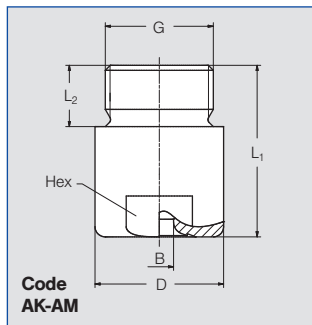
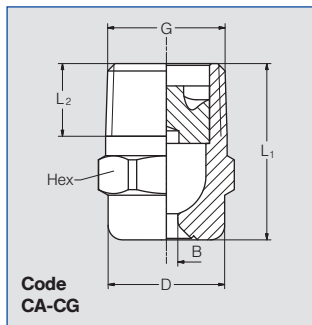

Code	G	Dimensions [mm]			Hex	Weight Brass
		L ₁	L ₂	D		
CA	1/8 BSPT	18.0	6.5	10.0	11	13 g
CC	1/4 BSPT	22.0	10.0	13.0	14	16 g
CE	3/8 BSPT	24.5	10.0	16.0	17	30 g
CE	3/8 BSPT	30.0	10.0	16.0	17	50 g
CG	1/2 BSPT	32.5	13.0	21.0	22	60 g
CG	1/2 BSPT	43.5	13.0	21.0	22	85 g
AK	3/4 BSPP	42.0	15.0	32.0	27	190 g
AK	3/4 BSPP	50.0	15.0	32.0	27	200 g
AM	1 BSPP	56.0	17.0	40.0	36	350 g

Subject to technical modification.

In a critical installation situation, please ask for the exact dimensions.

Spray angle	Ordering no.								B Ø [mm]	E Ø [mm]	V̇ [l/min]							Spray diameter D at p=2 bar		
	Type	Mat. no.		Code							p [bar]							Diagram		
		1Y	30	1/8 BSPT	1/4 BSPT	3/8 BSPT	1/2 BSPT	3/4 BSPP			1 BSPP	0.5	1.0	2.0	3.0	5.0	7.0	10.0	H = 200 mm	H = 500 mm
45°	490.403	○	○	CA	-	-	-	-	-	1.25	1.25	0.57	0.76	1.00	1.18	1.44	1.65	1.90	160	400
	490.523	○	○	CA	-	-	-	-	-	1.70	1.70	1.15	1.52	2.00	2.35	2.89	3.30	3.81	160	400
	490.603	○	○	-	CC	CE*	-	-	-	2.00	2.00	1.81	2.39	3.15	3.70	4.54	5.20	6.00	160	400
	490.643	-	○	-	-	CE	-	-	-	2.45	2.45	2.30	3.03	4.00	4.70	5.77	6.60	7.61	160	400
	490.683	-	○	-	-	CE	-	-	-	2.55	2.55	2.87	3.79	5.00	5.88	7.21	8.25	9.52	160	400
	490.703	-	○	-	-	CE	-	-	-	2.65	2.65	3.22	4.24	5.60	6.59	8.08	9.24	10.66	160	400
	490.723	○	○	-	-	CE	-	-	-	2.85	2.85	3.62	4.77	6.30	7.41	9.09	10.40	11.99	160	400
	490.783	-	○	-	-	-	CG	-	-	3.45	3.45	5.17	6.82	9.00	10.58	12.98	14.85	17.12	160	400
	490.843	-	○	-	-	-	CG	-	-	3.80	3.80	7.18	9.47	12.50	14.70	18.03	20.63	23.80	160	400
60°	490.404	○	○	CA	-	-	-	-	-	1.15	1.15	0.57	0.76	1.00	1.18	1.44	1.65	1.90	220	560
	490.444	○	-	CA	-	-	-	-	-	1.25	1.25	0.72	0.95	1.25	1.47	1.80	2.06	2.38	220	560
	490.484	○	○	CA	-	-	-	-	-	1.45	1.45	0.92	1.21	1.60	1.88	2.31	2.64	3.05	220	560
	490.524	○	○	CA	-	-	-	-	-	1.60	1.60	1.15	1.52	2.00	2.35	2.89	3.30	3.81	220	560
	490.564	○	○	CA	-	-	-	-	-	1.80	1.80	1.44	1.89	2.50	2.94	3.61	4.13	4.76	220	560
	490.604	○	○	CA	CC	CE	-	-	-	2.05	2.05	1.81	2.39	3.15	3.70	4.54	5.20	6.00	220	560
	490.644	○	○	-	CC	CE	-	-	-	2.30	2.30	2.30	3.03	4.00	4.70	5.77	6.60	7.61	220	560
	490.684	○	○	-	CC	CE	-	-	-	2.60	2.60	2.87	3.79	5.00	5.88	7.21	8.25	9.52	220	560
	490.724	○	○	-	CC	CE	-	-	-	2.95	2.80	3.62	4.77	6.30	7.41	9.09	10.40	11.99	220	560
	490.764	○	○	-	-	CE	-	-	-	3.25	3.25	4.59	6.06	8.00	9.41	11.54	13.20	15.22	220	560
	490.804	○	○	-	-	CE	-	-	-	3.70	3.70	5.74	7.58	10.00	11.76	14.43	16.51	19.04	220	560
	490.844	○	○	-	-	-	CG	-	-	4.05	4.05	7.18	9.47	12.50	14.70	18.03	20.63	23.80	220	560
	490.884	○	○	-	-	-	CG	-	-	4.65	4.65	9.19	12.13	16.00	18.82	23.08	26.41	30.46	220	560
	490.924	○	○	-	-	-	-	AK	-	5.20	5.20	11.49	15.16	20.00	23.52	28.85	33.01	38.07	220	560
	490.964	○	○	-	-	-	-	AK	-	5.80	5.80	14.36	18.95	25.00	29.40	36.07	41.26	47.59	220	560
	491.044	○	○	-	-	-	-	-	AM	7.25	7.25	22.97	30.31	40.00	47.04	57.71	66.02	76.15	220	560
	491.084	○	○	-	-	-	-	-	AM	8.15	8.15	28.72	37.89	50.00	58.80	72.14	82.53	95.18	220	560

*Only available in Material 30 · B = bore diameter · E = narrowest free cross section

Continued on next page.



Conversion formula for the above series: (≤ 10 bar)

$$\dot{V}_2 = \dot{V}_1 * \left(\frac{p_2}{p_1} \right)^{0.4}$$



Axial-flow full cone nozzles

Series 490 / 491

NEW Patent pending



Spray angle	Ordering no.									B Ø [mm]	E Ø [mm]	V̇ [l/min]								Spray diameter D at p=2bar	
	Type	Mat. no.		Code								p [bar]								 H = 200 mm H = 500 mm	
		1Y	30	1/8 BSPT	1/4 BSPT	3/8 BSPT	1/2 BSPT	3/4 BSPT	1 BSPP			0.5	1.0	2.0	3.0	5.0	7.0	10.0			
		316 L	Brass																		
90°	490.406	○	○	CA	-	-	-	-	-	1.20	1.20	0.57	0.76	1.00	1.18	1.44	1.65	1.90	380	860	
	490.446	-	○	CA	-	-	-	-	-	1.30	1.30	0.72	0.95	1.25	1.47	1.80	2.06	2.38	380	860	
	490.486	○	○	CA	-	-	-	-	-	1.45	1.45	0.92	1.21	1.60	1.88	2.31	2.64	3.05	380	860	
	490.526	○	○	CA	-	-	-	-	-	1.70	1.55	1.15	1.52	2.00	2.35	2.89	3.30	3.81	380	860	
	490.566	○	○	CA	-	-	-	-	-	1.90	1.90	1.44	1.89	2.50	2.94	3.61	4.13	4.76	380	860	
	490.606	○	○	CA	-	CE	-	-	-	2.10	2.05	1.81	2.39	3.15	3.70	4.54	5.20	6.00	380	860	
	490.646	○	○	-	CC	CE	-	-	-	2.40	2.40	2.30	3.03	4.00	4.70	5.77	6.60	7.61	390	960	
	490.686	○	○	-	CC	CE	-	-	-	2.70	2.70	2.87	3.79	5.00	5.88	7.21	8.25	9.52	390	960	
	490.726	○	○	-	CC	CE	-	-	-	3.20	2.80	3.62	4.77	6.30	7.41	9.09	10.40	11.99	390	960	
	490.746	○	○	-	-	CE	-	-	-	3.15	3.15	4.08	5.38	7.10	8.35	10.24	11.72	13.52	390	960	
	490.766	○	○	-	-	CE	-	-	-	3.40	3.40	4.59	6.06	8.00	9.41	11.54	13.20	15.22	390	960	
	490.806	○	○	-	-	CE	-	-	-	3.90	3.90	5.74	7.58	10.00	11.76	14.43	16.51	19.04	390	960	
	490.846	○	○	-	-	CE	-	-	-	4.65	4.00	7.18	9.47	12.50	14.70	18.03	20.63	23.80	390	960	
	490.886	○	○	-	-	-	-	CG	-	5.45	4.50	9.19	12.13	16.00	18.82	23.08	26.41	30.46	390	960	
	490.926	○	○	-	-	-	-	CG	-	5.90	4.50	11.49	15.16	20.00	23.52	28.85	33.01	38.07	390	960	
	490.966	○	○	-	-	-	-	CG	AK	6.55	4.85	14.36	18.95	25.00	29.40	36.07	41.26	47.59	390	960	
	491.006	○	○	-	-	-	-	CG	AK	7.55	5.50	18.09	23.87	31.50	37.05	45.45	51.99	59.97	390	960	
	491.046	○	○	-	-	-	-	-	AK	8.60	6.60	22.97	30.31	40.00	47.04	57.71	66.02	76.15	390	960	
	491.086	○	○	-	-	-	-	-	AK	9.45	7.25	28.72	37.89	50.00	58.80	72.14	82.53	95.18	390	960	
	491.126	○	○	-	-	-	-	-	AM	10.40	8.00	36.18	47.75	63.00	74.09	90.89	103.98	119.93	390	960	
491.146	○	-	-	-	-	-	-	AM	11.00	7.50	40.78	53.81	71.00	83.50	102.43	117.19	135.16	390	960		
120°	490.368	○	○	CA	-	-	-	-	0.85	0.65	0.36	0.48	0.63	0.74	0.91	1.04	1.20	680	1220		
	490.408	○	○	CA	-	-	-	-	1.20	1.20	0.57	0.76	1.00	1.18	1.44	1.65	1.90	680	1220		
	490.448	○	○	CA	-	-	-	-	1.30	1.30	0.72	0.95	1.25	1.47	1.80	2.06	2.38	680	1220		
	490.488	○	○	CA	-	-	-	-	1.45	1.45	0.92	1.21	1.60	1.88	2.31	2.64	3.05	680	1220		
	490.528	○	○	CA	-	-	-	-	1.70	1.70	1.15	1.52	2.00	2.35	2.89	3.30	3.81	680	1220		
	490.568	○	○	CA	-	-	-	-	1.90	1.90	1.44	1.89	2.50	2.94	3.61	4.13	4.76	680	1220		
	490.608	○	○	CA	-	-	-	-	2.10	2.05	1.81	2.39	3.15	3.70	4.54	5.20	6.00	680	1220		
	490.648	○	○	-	CC	CE	-	-	-	2.40	2.40	2.30	3.03	4.00	4.70	5.77	6.60	7.61	680	1330	
	490.688	○	○	-	CC	CE	-	-	-	2.75	2.75	2.87	3.79	5.00	5.88	7.21	8.25	9.52	680	1330	
	490.728	○	○	-	CC	CE	-	-	-	3.20	2.80	3.62	4.77	6.30	7.41	9.09	10.40	11.99	680	1330	
	490.748	○	○	-	-	CE	-	-	-	3.20	3.20	4.08	5.38	7.10	8.35	10.24	11.72	13.52	680	1330	
	490.768	○	○	-	-	CE	-	-	-	3.45	3.45	4.59	6.44	8.00	9.41	11.54	13.20	15.22	680	1330	
	490.808	○	○	-	-	CE	-	-	-	3.90	3.90	5.74	7.58	10.00	11.76	14.43	16.51	19.04	680	1330	
	490.848	○	○	-	-	CE	-	-	-	4.70	4.00	7.18	9.47	12.50	14.70	18.03	20.63	23.80	680	1330	
	490.888	○	○	-	-	-	-	CG	-	5.10	4.50	9.19	12.13	16.00	18.82	23.08	26.41	30.46	680	1330	
	490.928	○	○	-	-	-	-	CG	-	5.80	4.75	11.49	15.16	20.00	23.52	28.85	33.01	38.07	680	1330	
	490.968	○	○	-	-	-	-	CG	AK	6.65	4.85	14.36	18.95	25.00	29.40	36.07	41.26	47.59	680	1330	
	491.048	○	○	-	-	-	-	-	AK	9.20	5.85	22.97	30.31	40.00	47.04	57.71	66.02	76.15	680	1330	
	491.128	○	○	-	-	-	-	-	AM	10.80	7.75	36.18	47.75	63.00	74.09	90.89	103.98	119.93	680	1330	
	491.148	○	-	-	-	-	-	-	AM	11.40	7.65	40.78	53.81	71.00	83.50	102.43	117.19	135.16	680	1330	

B = bore diameter · E = narrowest free cross section

Other nozzle materials (special alloys, plastics) are available on request.

Example	Type	+	Material no.	+	Code	=	Ordering no.
for ordering:	490.406	+	1Y	+	CA	=	490.406.1Y.CA

Conversion formula for the above series: $\dot{V}_2 = \dot{V}_1 * \left(\frac{p_2}{p_1}\right)^{0.4}$ (≤ 10 bar)

