



Official Website



Company Wechat

Global Service Hotline : +86 4009-281-333

GoodWe (China)

No.189 Kunlunshan Rd.,SND,
Suzhou, 215163, China
T: +86 512 6239 6771
service@goodwe.com.cn
www.goodwe.com.cn

GoodWe (Europe)

Mürwikerstr. 59
24943 Flensburg Germany
T: +49 461 5897 0235
europe@goodwe.com.cn
www.goodwe.de

GoodWe (Australia)

19 Fairleigh Street, Glenroy,
VIC, 3046, Australia
T: +61 3 9324 0559
australia@goodwe.com.cn
www.goodwe.de

GoodWe (Netherlands)

Zevenwouden 194 ,
3524 CX Utrecht, the Netherlands
T: +31 6 1988 6498 +31 6 1784 0429
service@goodwe.com.cn
www.goodwe.com.cn

GoodWe (UK)

93 Caversham Place
Sutton Coldfield B73 6HW
T: +44 12 1238 0053
uk@goodwe.com.cn
www.goodwe.com.cn

Note: The contact information above is subject to change without notice. please refer to the company's website at www.goodwe.com.cn.

350-00014-06



DT/Smart DT SERIES USER MANUAL



SOLAR INVERTER

1 Symbols	01
------------------------	----

2 Safety and Warning	01
-----------------------------------	----

3 Installation	
3.1 Mounting Instruction	02
3.2 Overview and Packaging	02
3.3 Inverter Installation	03
3.4 Electrical Connection	05

4 System Operation	
4.1 LED Lights	12
4.2 User Interface and Controls	12
4.3 Error Code	17
4.4 WiFi Reset & WiFi Reload	17











5 Troubleshooting	18
--------------------------------	----

6 Technical Parameters and Block Diagram	
6.1 Technical Parameters	19
6.2 Block Diagram	24

7 Maintenance	
7.1 Cleaning the Fans	25
7.2 Checking the DC Switch	26

8 Certificates	26
-----------------------------	----

1 Symbols

	Caution! - Failure to observe a warning indicated in this manual may result in minor or moderate injury.		Components of the product can be recycled.
	Danger of high voltage and electric shock!		This side up - The package must always be transported, handled and stored in such a way that the arrows always point upwards.
	Danger of hot surface!		No more than six (6) identical packages be stacked on each other.
	Product should not be disposed as normal household waste.		The package/product should be handled carefully and never be tipped over or slung.
	CE Mark		Keep Dry – The package/product must be protected from excessive humidity and must accordingly be stored under cover.
	Signals danger due to electrical shock and indicates the time (5 minutes) to allow after the inverter has been turned off and disconnected to ensure safety in any installation operation.		

2 Safety and Warning

DT/ Smart DT (hereinafter referred to as SDT) series inverter of Jiangsu GoodWe Power Supply Technology Co.,Ltd. (hereinafter referred to as GoodWe) strictly conforms to related safety rules in design and test. As electric and electronic equipment, Safety Regulation shall be followed during installation and maintenance. Improper operation may bring severe damage to the operator, the third party and other properties. (DT: Dual-MPPT, Three-Phase, covering 09kW/10kW/12kW/15kW/17kW/20kW/25kW; SDT: Smart Dual-MPPT, Three-Phase, covering 4kW/5kW/6kW.)

- Installation, maintenance and connection of inverters must be performed by qualified personnel, in compliance with local electrical standards, regulations and the requirements of local power authorities and/or companies.
- To avoid electric shock, DC input and AC output of the inverter must be terminated at least 5 minutes before performing any installation or maintenance.
- The temperature of some parts of the inverter may exceed 60°C during operation. To avoid being burnt, do not touch the inverter during operation. Let it cool before touching it.
- Keep children away from the inverter.
- Without permission, open the front cover of the inverter is not allowed. Users should not touch/replace any of the components except for the DC/AC connectors. GOODWE will not bear any consequences caused by unauthorized actions which will lead to potential injury to people and damage to inverters.
- Static electricity may damage electronic components. Appropriate method must be adopted to prevent such damage to the inverter; otherwise the inverter may be damaged and the warranty will be annulled.
- Ensure the output voltage of the proposed PV array is lower than the maximum rated input voltage of the inverter; otherwise the inverter may be damaged and the warranty will be annulled.

- When exposed to sunlight, the PV array will generate very high voltage which will cause potential danger to people. Please strictly follow the instruction we provided.
- PV modules should have an IEC61730 class A rating.
- If the equipment is used in a manner not specified by the manufacturer, the protection provided by the equipment may be impaired.
- Completely isolate the equipment should : switch off the DC switch, disconnect the DC terminal, and disconnect the AC terminal or AC breaker.
- Prohibit inserting or pulling the AC and DC terminals when the inverter is working.
- Only DC connectors provided by GoodWe are permitted to use, otherwise the inverter may be damaged and the warranty will be annulled.
- Person could access to inverter status through mobile phone and computer display please refers to chapter 3.4.4 and 3.4.5. and error code could be shown not only on inverter LCD display but also mobile phone APP interface.

3 Installation

3.1 Mounting Instruction

- In order to achieve optimal performance, the ambient temperature should be kept lower than 45 °C.
- For the convenience of checking the LCD display and possible maintenance activities, please install the inverter at eye level.
- Inverters should NOT be installed near inflammable or explosive items. Any strong electro-magnetic equipment should be kept away from installation site.
- Product label and warning symbol shall be clear to read after installation.
- Please do not install inverter under direct sunlight, rain and snow.

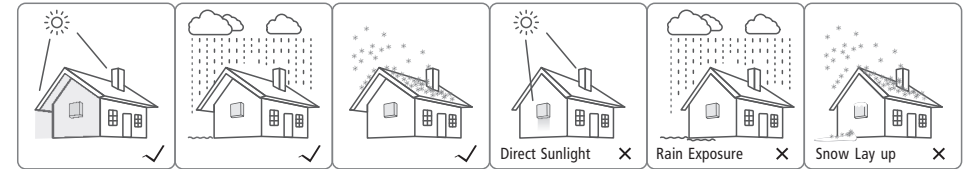

3.2 Overview and Packaging

After opening the package, confirm if it is consistent with specification of inverter you purchased.

3.2.1 Inverter Overview

DT Series inverter illustration.

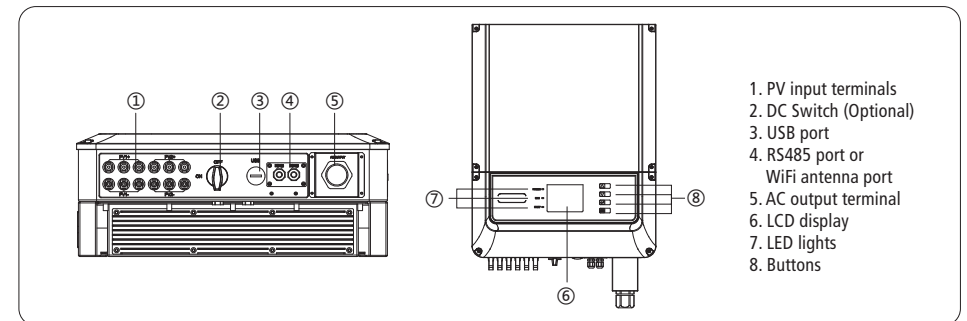

SDT Series inverter illustration.

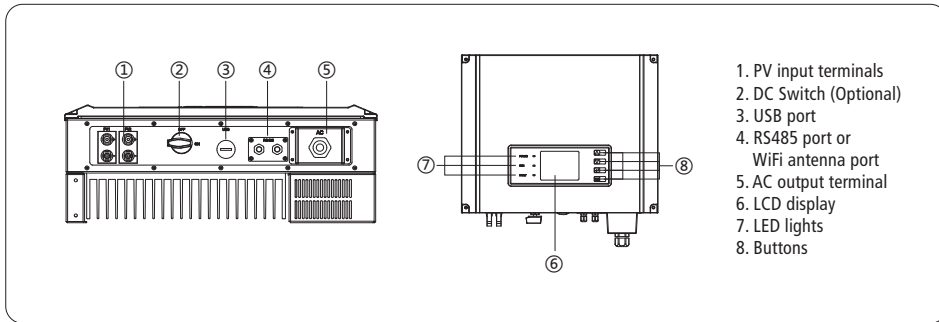

3.2.2 Package

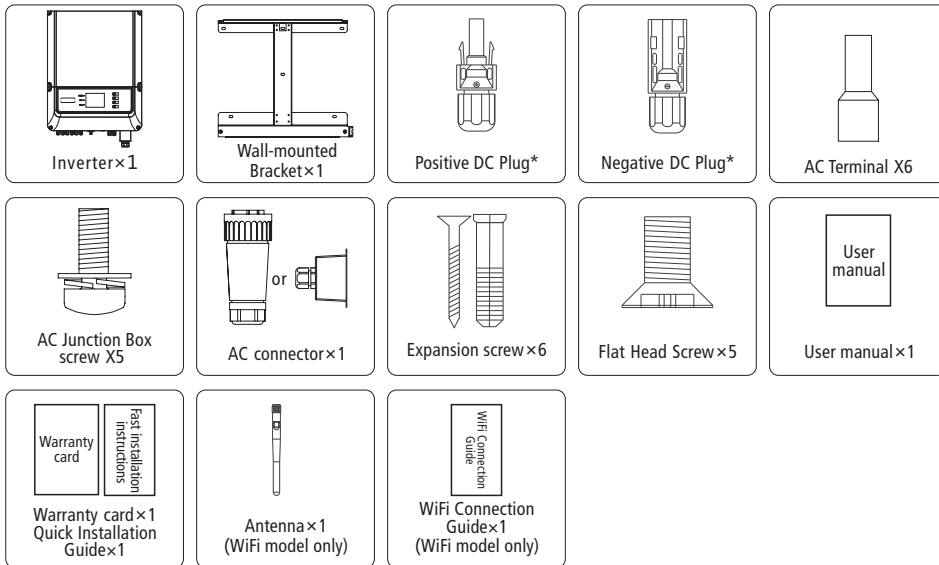

*Positive DC Plug: 09~12kW 3 pairs; 15~20kW 4 pairs; 25kW 6 pairs; 4~6kW 2 pairs.
 *Negative DC Plug: 09~12kW 3 pairs; 15~20kW 4 pairs; 25kW 6 pairs; 4~6kW 2 pairs.

3.3 Inverter Installation

3.3.1 Selecting the Installation Position

Installation position should be selected based on the following aspects:

- The installation method and mounting location must be suitable for the inverter's weight and dimensions.
- Mount on a solid surface.
- Select a well ventilated place sheltered from direct sun radiation.

- Install vertically or tilted backward by max 15°. The device can not be installed with a sideways tilt. The connection area must point downwards. Refer to Figure 3.3.1-1.

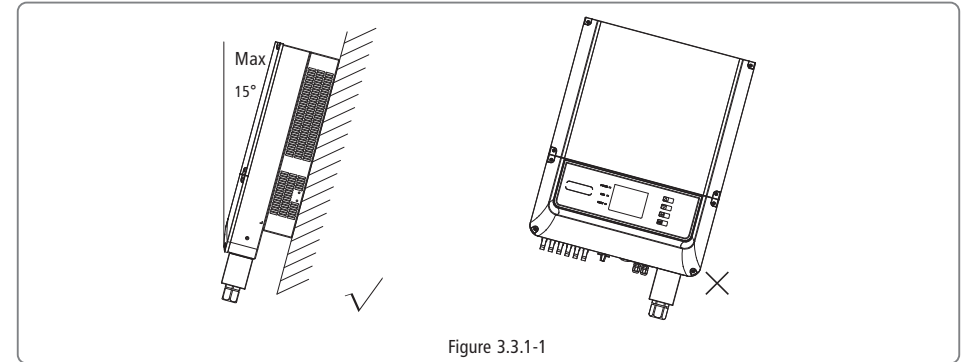

- In consideration of heat dissipation and convenient dismantlement, the minimum clearances around the inverter should be no less than the following value:

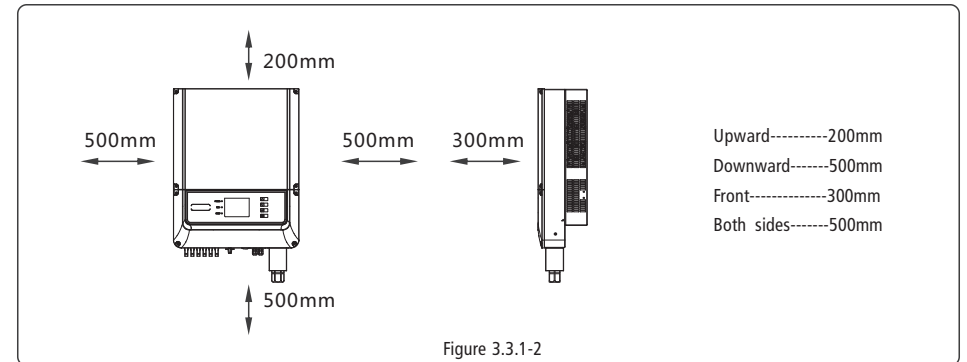

3.3.2 Mounting Procedure

- (1) Use the wall-mounted bracket as a template and drill 6 holes on the wall, 10 mm in diameter and 80 mm deep. The inverter sizes of DT series please refer to Figure 3.3.2-1, and the size of SDT series refer to Figure 3.3.2-2.
- (2) Fix the wall mounting bracket on the wall with six expansion bolts in accessory bag.
- (3) Hold the inverter by the groove on it, (DT models please refer to Figure 3.3.2-3, and SDT models refer to Figure 3.3.2-4.)
- (4) Place the inverter on the wall-mounted bracket as illustrated in Figure 3.3.2-5, 3.3.2-6, 3.3.2-7.

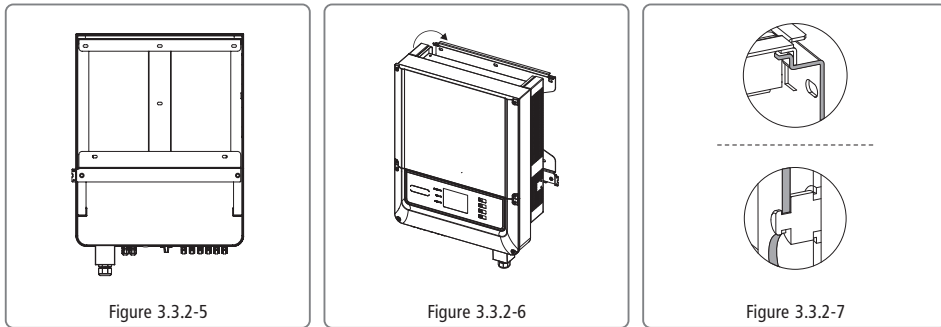
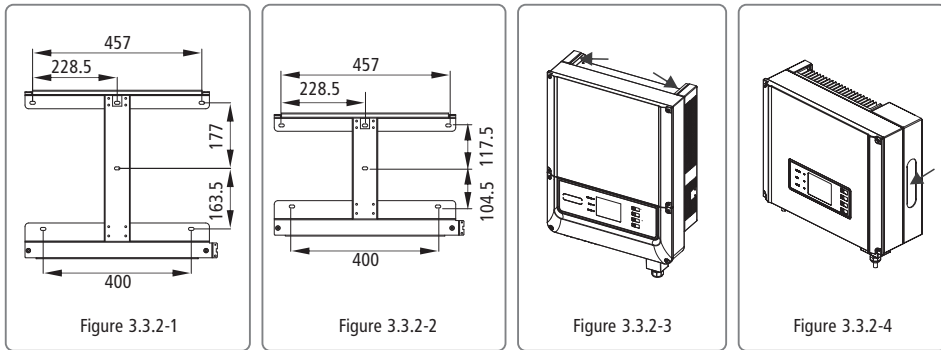

3.4 Electrical Connection

3.4.1 Connection to Grid (AC Side Connection)

- (1) Check the grid voltage and frequency, select a suitable safety standard from inverter that comply with this requirements.
- (2) Add breaker or fuse to AC side, the specification should be more than 1.25 times of rated AC output current.
- (3) The PE line of inverter should be connected to the earth, make sure the impedance of neutral wire and earth wire less than 10 ohm.
- (4) Disconnect the breaker or fuse between the inverter and the utility.
- (5) Connect the inverter to the grid as follows:

There are two AC connector brands for inverter,---VACONN Series and Waterproof Coupling Series, please refer to Figure 3.4.1-1.

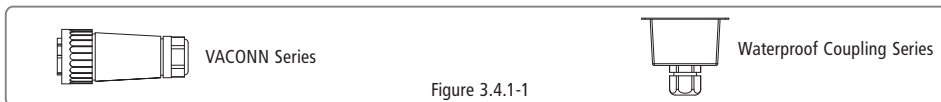

Installation instruction of VACONN series connector please refer to Figure3.4.1-2.

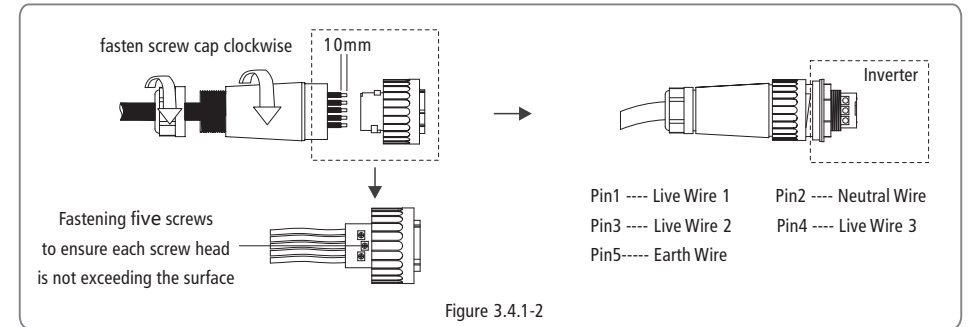

Installation instruction of waterproof coupling series connector please refer to Figure 3.4.1-3.

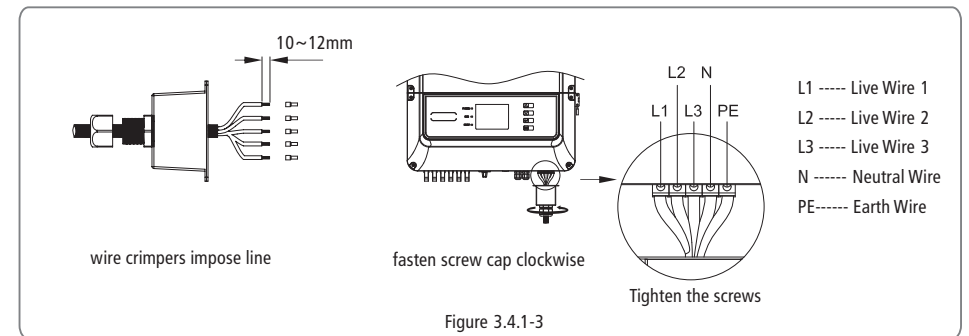

AC cable illustration please refer to Figure 3.4.1-4.

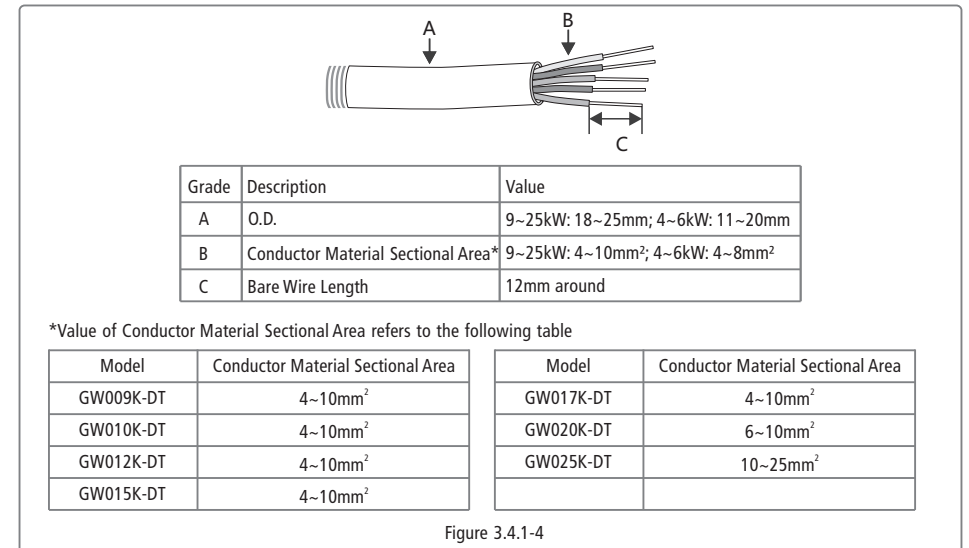

Grid compatibility

DT series GW09K-DT~GW25K-DT and SDT series support four different types of grid. please refer to Figure 3.4.1-5.

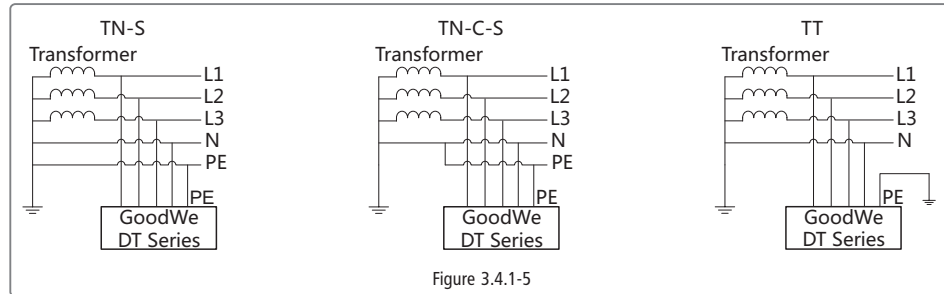

Figure 3.4.1-5

Note : For TT grid structure, RMS voltage between neutral wire and earth wire must be less than 20V.

3.4.2 DC Side Connection

- (1) Before connecting PV string, make sure DC switch is turned off .
- (2) Make sure PV string polarity confirms with DC connector, otherwise, it will cause damage to inverter.
- (3) Make sure the maximum open circuit voltage (Voc) of each PV string does not exceed the inverter input voltage V_{max} under any condition.
- (4) Do not connect positive or negative pole of PV string to earth wire. Otherwise, it will cause damage to inverter.

Installation instruction of MC4 connectors please refer to Figure 3.4.2-1 or Figure 3.4.2-2.

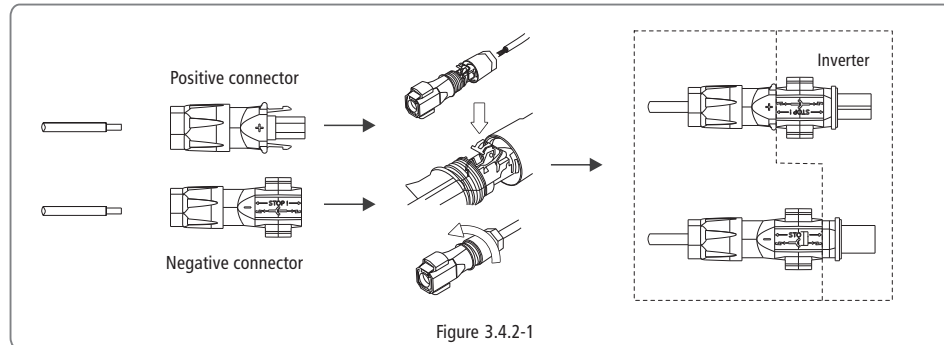

Figure 3.4.2-1

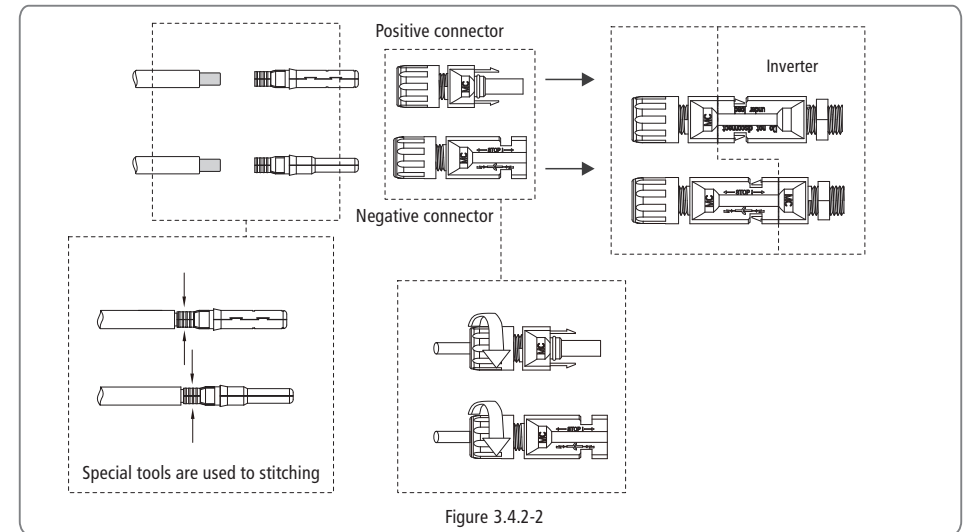

Figure 3.4.2-2

DC Cable specification please refer to Figure 3.4.2-3.

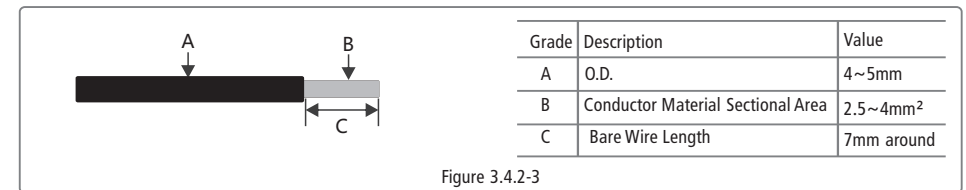

Figure 3.4.2-3

For better inverter IP65 protection from water and dust, all pairs of DC connectors provided in accessory bags should be used. However, if there is still extra pairs unused after installation, please make sure the unused pairs still be connected to the inverter with exposed wires compressed, the exposed wires should be at least kept 15mm out of DC connectors, please refer to Figure 3.4.2-4. Otherwise, DC connector protecting cover in the accessory bag could be used to cover the exposed DC connector.

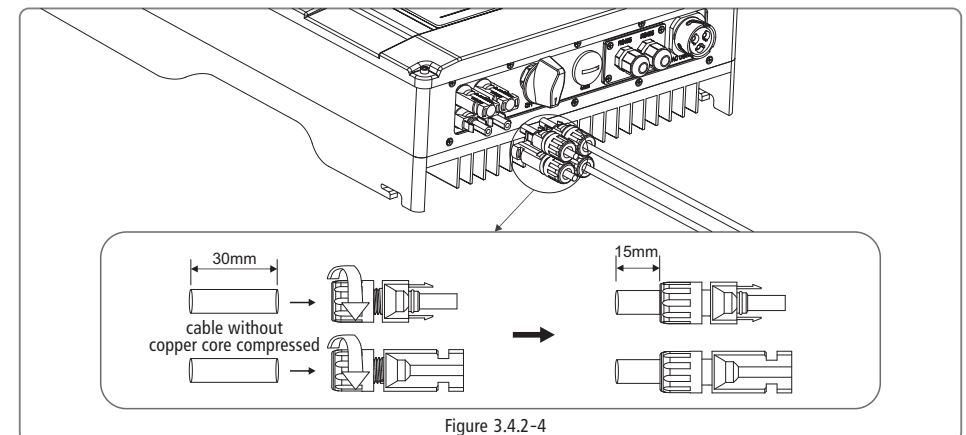
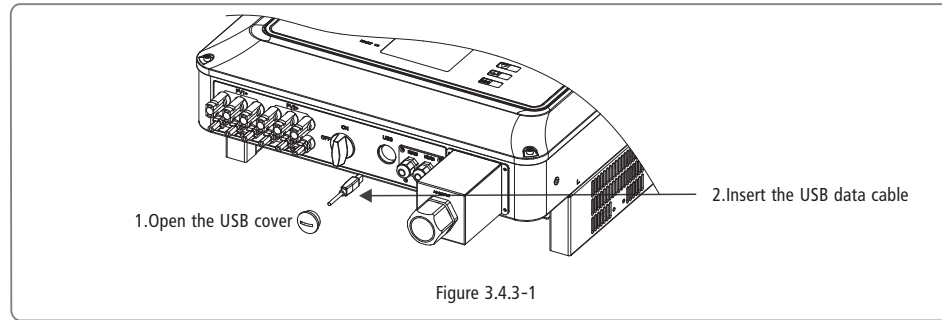

Figure 3.4.2-4

3.4.3 USB Communication

USB cable should be connected as Figure 3.4.3-1.



If you need USB communication, please download EzExplorer software at www.goodwe.com.cn.

3.4.4 RS485 Communication

This function only applies to inverter with RS485 ports.

The RS485 interface is used to connect EzLogger only, please make sure the connecting cables not exceed 800m.

RS485 connection please refer to Figure 3.4.4-1.

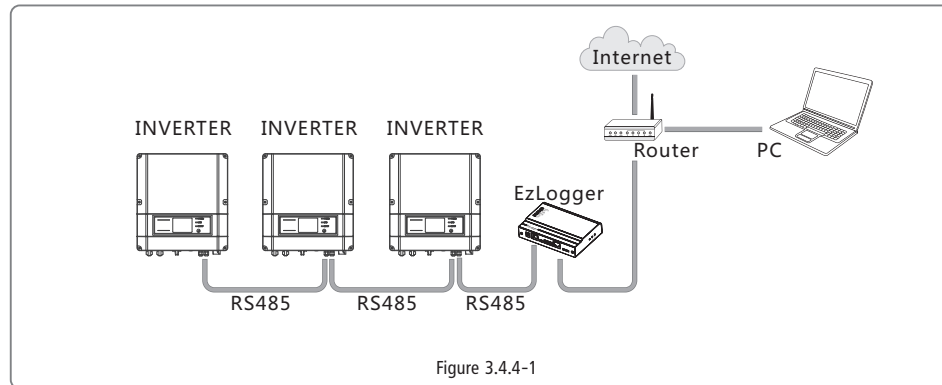

(1) Connection procedure:

- Remove the waterproof kit of RS485 cover with screwdriver.
- Remove the screw cap of the cable gland.
- Remove the one-hole sealing ring.
- Insert the RS485 cable through the components as the followings: screw cap, one-hole sealing ring, insulation body and sheet metal parts.
- Compress 8 cores of cable into the corresponding interface of crystal head. Please refer to Figure 3.4.4-2.
- Connect the compressed crystal head to the port of RS485.
- Fasten the RS485 waterproof kit to inverter.
- Fasten the screw cap of the cable gland.

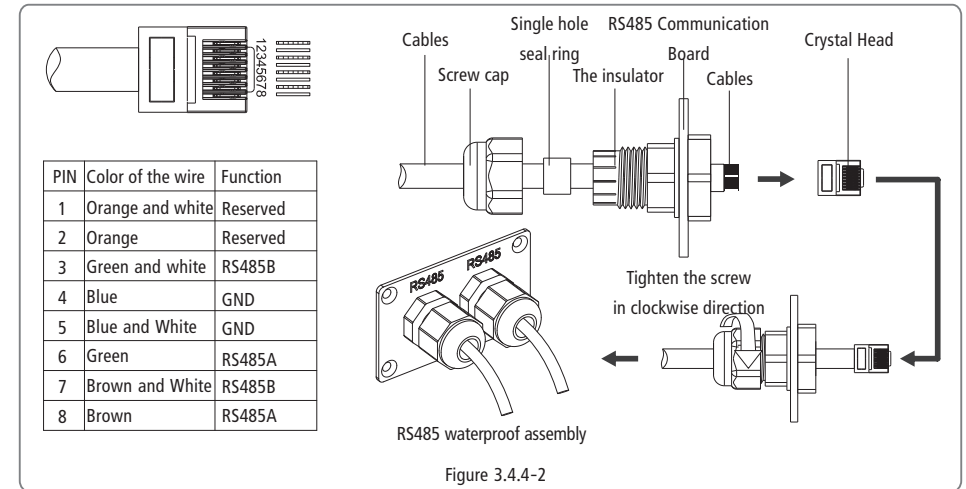

(2) Connect the inverter to EzLogger with RS485 cable, and EzLogger to switch or router with CAT5E STP cable.

Notice

The requirement of RS485 communication cable: STP or Ethernet cable of STP type

(3) The choice of 120ohm termination resistor dip switch.

- If there is only one GoodWe DT inverter, RS485 connection cable with waterproof RJ45 plug can realize connection.
- For single inverter communication, choose one among the two RJ45 ports. Please use a waterproof cover to cover the port which is not used.
- For single inverter communication, put on the 120ohm termination resistor dip switch near RJ45 port. (The default is OFF). Then shielding layer of communication cable is single point grounding.

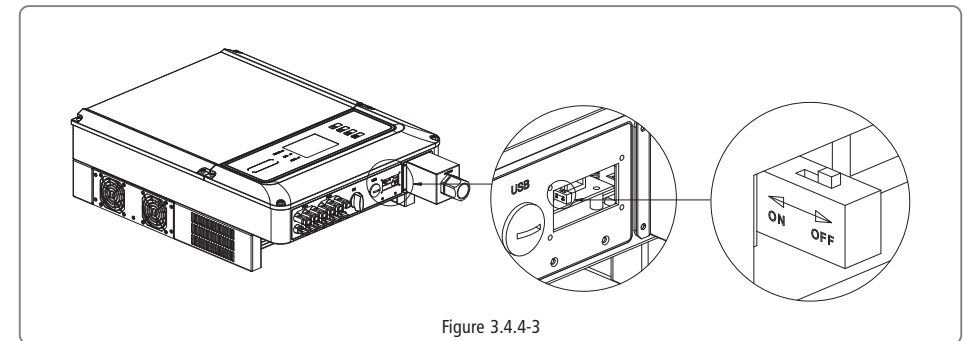

●If there are several GoodWe PV inverters, their connection can be realized by RS485 communication cables which are in daisy chain connection.

●For the end inverter in daisy chain, put on the 120ohm termination resistor dip switch near RJ45 port. (The default is OFF).Then shielding layer of communication cable is single point grounding.

(4) RS485 communication connection method

●GoodWe DT inverter can be connected with Ezlogger separately for data acquisition and monitoring. It can be also connected with PC terminal via Ezlogger to realize communication.

●The connection method of single GoodWe DT inverter, Ezlogger and PC terminal is show in Picture3.4.4-4. The connection method of several GoodWe DT inverters, Ezlogger and PC terminal is show in Picture3.4.4-5.

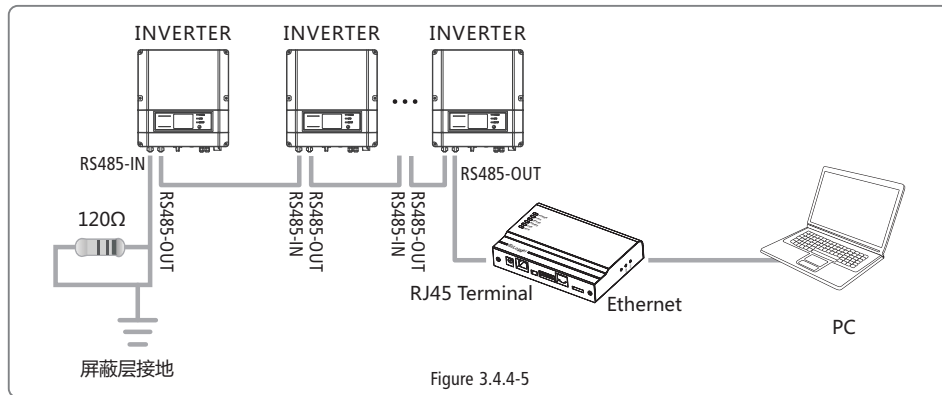
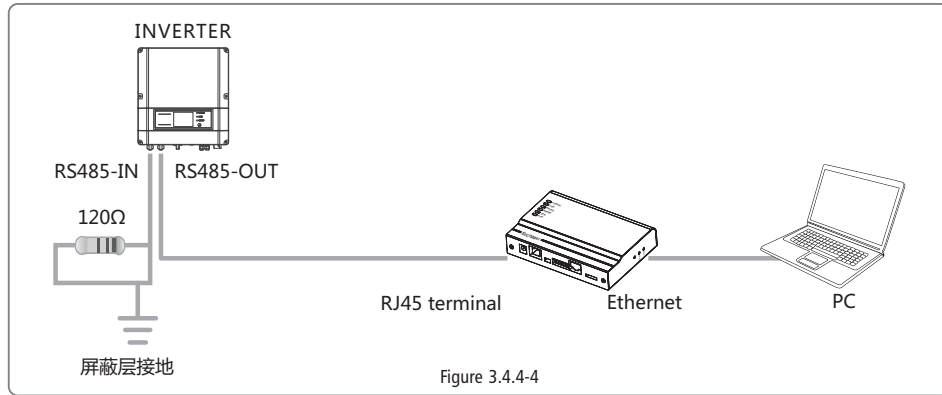

If several GoodWe DT inverters linked together with Ezlogger, the inverter number in daisy chain could be 16 at most.

3.4.5 WiFi Communication

The WiFi communication function is only applied to WiFi models, the detailed configuration instruction can be referred to WiFi configuration in the accessory box or the "WiFi Monitoring Vedio" on the official website, <http://www.goodwe.com.cn/en/Download.aspx>.

After configuration, please browse <http://www.goodwe-power.com> to create PV station.

4 System Operation

4.1 LED Lights



LED lights in Yellow/Green/Red correspondently refer to POWER/RUN/FAULT.

Yellow: Light on indicates the inverter is electrified.

To WiFi model inverters, If the Power light flashes every 0.5sec, it indicates the connection between inverter and your WiFi router is abnormal; If the Power light flashes every 2.5sec, it indicates the inverter has successfully connected to your WiFi router however connection with Web Server is abnormal; If the Power light keeps on continuously, it indicates WiFi monitoring is all normal.

Green: If the RUN light keeps on, it indicates inverter operating normally. If the RUN light is flashing, it indicates the inverter is undertaking self-checking.

Red: If the Fault light keeps on, it indicates inverter abnormal conditions and require service.

4.2 User Interface and Controls

Set Safety Country :

If display shows 'Configure Safety', then long press (2S) the key to enter the second level menu. Short press to browse the safety country list available. Choose suitable safety country according to the location of installation. The inverter will store the chosen safety country after 20 seconds if no operation.

(1) The Figure of LCD display screen is shown as follow:

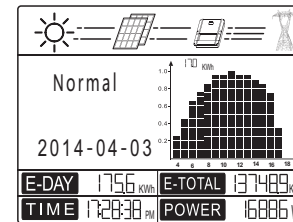

Display area is divided as follows:

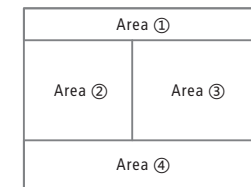

(2) Display area

Area①——Flow of Power Generated:

Area① indicates the flow of energy. Full line (—)between inverter and the grid means the grid is available but inverter is not yet feeding power at the time. Flashing dashed lines (---) mean inverter is feeding power to grid. No line means grid is not available. Flashing dashed lines between the sun, modules and inverter means there is energy from the sun to modules and then from modules to inverter.

Area②——Status Information:

Area② displays inverter power generation status. Different inverter status like languages & time settings, error logs, historical power information etc could all be switched and displayed here through button operations.

Area 2 has 3 levels of menu. Please refer to the diagram below.

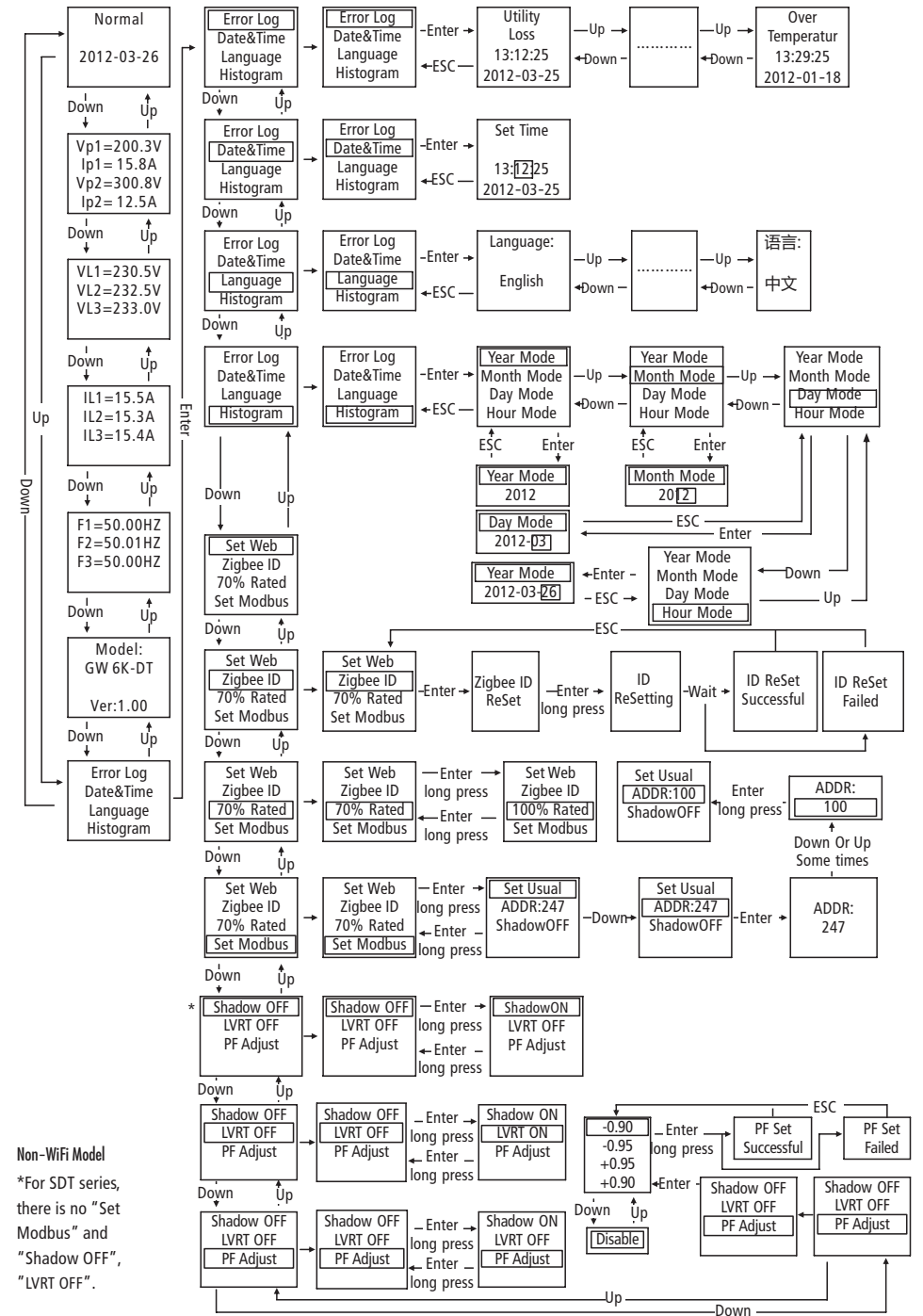
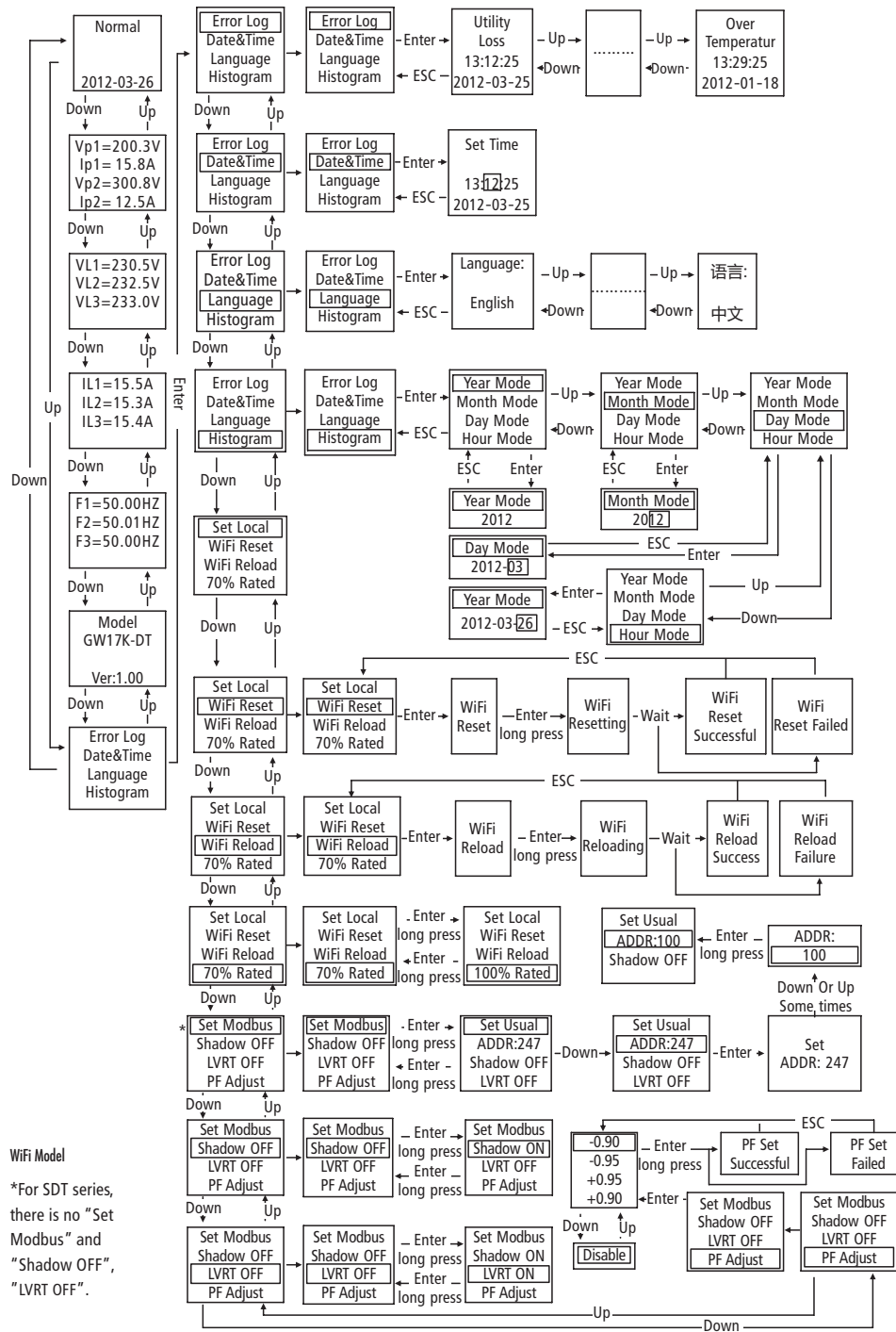

Area③——Histogram Display:

Area③ uses histogram to demonstrate the average power generation at each hour from 4:00am to 8:00pm on one day. Each columnar points 20 scale, the left top area shows the maximum rated power generation each hour for inverter.

This area can display information in different modes, There are 5 display modes in total: real-time mode, hour mode, day mode, month mode, year mode.

Real-time mode: display hourly power generation from 4:00am to 8:00pm;

Hour mode: display the hourly power generation in a specific day from recent 14 days;

Day mode: display the daily power generation in a specific month from recent 6 months;

Month mode: display the monthly power generation for 12 months in specific year;

Year mode: display annual power generation for recent 10 years.

Take day mode for example:

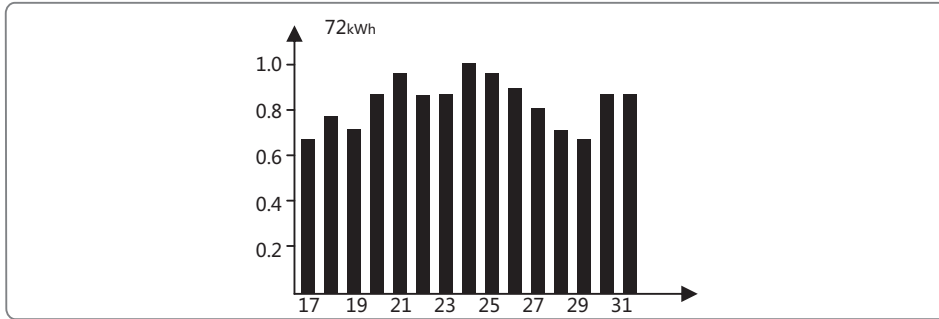

72kWh means the maximum power generation of recent 16 days. The unit on the left corner sometimes turns to "MWh" from "kWh", it depends on Maximum power generation. 0.2~1.0 on the left is scare factor, which is fixed display content; 17~31 are based on current mode which shows the bar chart label.

Area④ Displays total power generation, daily power generation, real-time power generation and time information, described as follow:

Area	Description
E-DAY	Daily power generation
E-TOTAL	Gross power generation after first time use of inverter. The initial unit is "kWh"; When power generation exceeds 999.9kWh, the unit changes to "MWh".
TIME	Current system time
POWER	Real-time power generation of the system

(3)Use of the display and LCD display :

The buttons near the LCD screen are mainly used for inverter information display, setting of time, language selection and histogram information display.

The menu in LCD display area has three levels; In the level 1 menu, first 6 interfaces showing inverter status, model, PV voltage and current, grid voltage and current, line frequency. Pressing button "Enter" to lock current menu interfaces in order to observe specific parameter. In the meanwhile, backlight will turn on for 1 min; Press "Enter" to unlock the interface for information display, the backlight will be kept on for 30S and then switch back to default initial interface.

The last interface (including error Log, time and data, language setting and historical electricity generation) can be entered by pressing 'Enter' to according Level 2 menu.

In level 2 menu, move the cursor to the setting area through 'DOWN' and 'UP' key operation. For the level 2 menu which has three level menus, press 'ENTER' to get in and change the figures at cursor location through 'DOWN' and 'UP' key operation, in addition, the cursor location can be changed by pressing 'ENTER'.

In all levels of menu, it will automatically enter the first item of the level 1 menu if no action is taken within 30S, meanwhile, the modified data will be stored into internal memory.

(4) Menu introduction:

Long press 'ENTER' in the Configure Safety interface, there will be set safety interface .press 'Down' or 'Up' to choose the safety you need and then long press 'ENTER', the safety you need can be set.

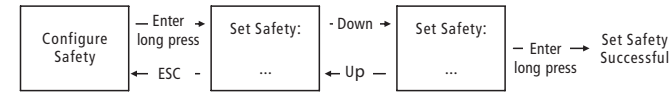

- When PV panel is feeding power to the inverter, the screen shows the first interface of level 1 menu. The interface displays current state of the system. It shows 'Waiting' in the initial state; it shows 'Normal' during power generation mode; if there is something wrong with the system, error message is shown. Error code can be referred to 4.3.
- Press any key once to turn on the LCD backlight when it is off; if the backlight is on, press 'DOWN' key to enter the next menu displaying data of Vpv and Ipv; press 'ENTER' to lock the current interface.
- In the level 1 menu, the displayed information can be switched through 'DOWN' and 'UP' key operation, there are 7 interfaces in total, which are circulatory. The level 2 menu can only be selected through 'ENTER' from the seventh interface.
- In the level 2 menu, short press 'Error Log' to enter the historical error message interface, press 'up' and 'down' to inquire the first 5 historical error message, press 'Esc' to return.
- In the level 2 menu, short press 'Date&Time' to enter the time setting interface, press 'up' and 'down' to change the data, short press 'Enter' to move cursor, long press 'Enter' to save the settings.
- In the level 2 menu, choose 'Language' and press 'Enter' to enter language setting interface, the LCD will flash, press 'up' or 'down' to change language, long press 'Enter' to save the settings, when it stops flashing, press 'Esc' to return.
- In the level 2 menu, choose 'Histogram', short press 'Enter' to enter the level 3 menu to inquire the historical power generation, in the level 3 menu, press 'up' or 'down' to inquire power generation data in Year Mode, Month Mode, Day Mode and Hour Mode, short press 'Enter' to show the historical power generation, press 'Esc' back to main menu.
- In the level 2, the Menu after 'Histogram' is communication selecting interface, if it is WiFi model, It shows as 'Set Zigbee' (It shows as 'Set Local' for the SDT series). Long press 'Enter', It becomes 'set Web', the communication type turn into non WiFi model, long press 'Enter' to back to 'Set Zigbee', the communication mode turns back to WiFi model.
- In the level 2 menu, if it is WiFi model, please choose 'WiFi Reset' or 'WiFi Reload' and short press 'Enter' to enter the interface. Then long press 'Enter' will reset or reload the inverter WiFi mode. Wait for 25 seconds, operation result will show on display. Press 'Esc' to return.
- In the level 2 menu, if it is non-WiFi model, please choose 'Zigbee ID' and short press 'Enter'. The display shows 'Zigbee ID Reset', long press 'Enter' to reset the inverter Zigbee ID mode. Wait for 25 seconds, operation result will show on display. Press 'Esc' to return. (Notice: The operation only suits the Zigbee mode inverter.)
- In the level 2 menu, long press 'Set Modbus' to get 'Set Usual' and an added menu 'ADDR: 247'. Press "Down" to choose 'ADDR: 247' and short press 'Enter' to enter Modbus address interface. Press 'Up' or "Down" to set the address.

⚠ This function is used for special requirements.

- Long press 'ENTER' in the model type interface, there will be set safety interface. Press 'Down' or 'Up' to choose the safety you need and then long press 'ENTER', the chosen safety will be set. If there is no EXACTLY proper country code, please choose '50Hz Grid Default' or '60Hz Grid Default' accordingly.

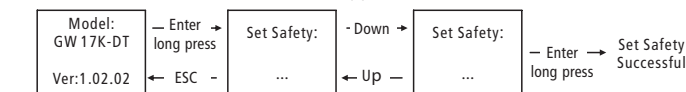

⚠ This function is used for special requirements.

- In the level 2 menu, choose 'Shadow OFF' (if shadow mode has not been turned on), long press 'Enter', it shows 'Shadow ON' indicating shadow mode has been successfully turned on. (Only available for DT series.)

 This function is used for special requirements.

- In the level 2 menu, choose '70% Rated', at this time, the inverter is 100% output power, long press 'Enter', it becomes '100% Rated', then the output power will be limited to 70%. The function is only for using with VDE AR-N 4105 standard or in France areas, and only for service person. Misuse will cause the inverter derating. This menu is not shown for other standards.

 This function is used for special requirements.

(5) Operation of Display when commissioning.

When the input voltage reaches inverter turn-on voltage, LCD displays 'waiting'. If the grid is accessible, 'Checking xxx Sec'(The time is decided by the grid connection standards from different country) will be shown up in 5sec, During the counting, the inverter is self-checking, when it shows '00Sec' you can hear the relay triggers, LCD displays 'Normal' afterwards. The instant power output will be shown at the right bottom of LCD.

4.3 Error Code

The error message in below diagram will be displayed on the LCD if a fault occurs.

Error code	Error message	Description
01	SPI Failure	Internal communication failure
02	EEPROM R/W Failure	Memory chip failure
03	Fac Failure	Grid frequency out of range
07 , 25	Relay Check Failure	Relay self-checking failure
13	DC Injection High	Overhigh DC injection
14	Isolation Failure	Ground insulation impedance is too low
15	Vac Failure	Grid voltage out of range
16	EFan Fault	External Fan Failure
17	PV Over Voltage	Overvoltage at DC input
19	Over Temperature	Overtemperature on the case
20	IFan Fault	Internal Fan Failure
21	DC Bus High	Overhigh BUS voltage
22	Ground I Failure	Overhigh ground leakage current
23	Utility Loss	Grid disconnection/fault
30	Ref 1.5V Failure	1.5V reference voltage failure
31 , 24	AC HCT Failure	Output current sensor failure
32 , 26	GFCI Failure	Detection circuit of ground leakage current failure
Others	Device Failure	Internal device failure

4.4 WiFi Reset & WiFi Reload

Choose 'WiFi Reset' button in level 1, short press 'enter' to enter level 2 menu 'WiFi Reset'; long press 'Enter' to reset inverter WiFi model; wait for a while, operation result will show on display, the function can be applied when inverter is unable to connect to router or monitor server.

Choose 'WiFi Reload' button in level 1, short press 'WiFi Reload' to enter level 2 menu 'WiFi Reload'; long press 'enter' button will reload the inverter WiFi model to initial setting. Wait for a while, operation result will show on display, the function can be applied when inverter is unable to connect to WiFi model. Once WiFi model restore initial setting, WiFi model need be reset again.

Notice : WiFi model only.

5 Troubleshooting

If the Inverter is not able to work properly, please refer to the following instructions before contact your local service. Should any problems arise, the red (FAULT) LED indicator on the front panel lights up and the LCD screen will display relevant information. Please refer to the following table for a list of error message and associated solutions.

	Display	Possible actions
System Fault	Isolation Failure	<ol style="list-style-type: none"> 1. Check the impedance between PV (+) & PV (-) and make sure the inverter is earthed. The impedance value must be greater than 200kΩ. 2. Contact local service office for help if the problem still exists.
	Ground I Failure	<ol style="list-style-type: none"> 1. The ground current is too high. 2. Unplug the inputs from the PV generator and check the peripheral AC system. 3. When the problem is cleared, reconnect the PV panel and check the Inverter status. 4. Contact local service office for help if the problem still exists.
	Vac Failure	<ol style="list-style-type: none"> 1. The PV Inverter will automatically restart within 5 minutes if the grid returns to normal. 2. Make sure grid voltage is in conformity with the specification. 3. Make sure Neutral (N) Wire and PE wire is connected well. 4. Contact local service office for help if the problem still exists.
	Fac Failure	<ol style="list-style-type: none"> 1. The PV Inverter will automatically restart within 5 minutes if the grid returns to normal. 2. Make sure grid frequency is in conformity with the specification. 3. Contact local service office for help if the problem still exists.
	Utility Loss	<ol style="list-style-type: none"> 1. Grid is not connected. 2. Check grid connection cables. 3. Check grid usability.
Inverter failure	PV Over Voltage	<ol style="list-style-type: none"> 1. Check whether the PV open voltage is higher or too close to the maximum input voltage. 2. If the problem still exists when PV voltage is less than the maximum input voltage, contact local service office for help.
	Over Temperature	<ol style="list-style-type: none"> 1. The internal temperature is higher than normal value specified. 2. Reduce ambient temperature. 3. Move the inverter to a cool place. 4. If the problem still exists, contact local service office for help.
	Relay-Check Failure	<ol style="list-style-type: none"> 1. Turn off DC switch of the inverter. 2. Wait till inverter LCD unlighted. 3. Turn on DC switch and make sure it connected. 4. If the problem still exists, contact local service office for help.
	DC Injection High	
	EEPROM R/W Failure	
	SCI Failure	
	SPI Failure	
	DC Bus High	
GFCI Failure		
IFan Fault		
EFan Fault		
AFan Fault		
	No display	<ol style="list-style-type: none"> 1. Turn off DC switch, take off DC connector, check inverter module voltage. 2. Plug in DC connector, and turn on DC switch. 3. If voltage is lower than 250V⁽¹⁾, please check configuration of invert module. 4. If voltage is higher than 250V⁽¹⁾, please contact local office.

Notice: 1. At the place that marked ⁽¹⁾ in the chart, GW10K/12K/15K/17K/20K/25K-DT is 250V, GW4000/5000/6000-DT is 180V.
 2. When sunlight is insufficient, the PV Inverter may continuously start up and shut down automatically due to insufficient power generated by the PV panel.

6 Technical Parameters and Block Diagram

6.1 Technical Parameters

Model	GW09K-DT	GW10K-DT	GW12K-DT	GW15K-DT	GW17K-DT	GW20K-DT	GW25K-DT
DC input Data							
Max. DC power(W)	9200	10200	12300	15400	17500	20500	25800
Max. DC voltage (V)	1000	1000	1000	1000	1000	1000	1000
MPPT voltage range (V)	260~850	260~850	260~850	260~850	260~850	260~850	260~850
Starting voltage (V)	250	250	250	250	250	250	250
Max. DC current (A)	22/11	22/11	22/11	22/22	22/22	22/22	27/27
Max. inverter backfeed current to the array (A)	0						
DC overcurrent protection(A)	33	33	33	33	33	33	38
No. of DC connectors	3	3	3	4	4	4	6
No. of MPPTs	2	2	2	2 (can parallel)			
DC overvoltage category	Category II						
DC connector	MC4 / SUNCLIX (optional)						
PV input operating voltage range	280V ~910Vdc						
Isc PV(absolute maximum)	27A / 20A		27A/27A			32A/32A	
AC Output Data							
Norminal AC power(W)	9000	10000	12000	15000	17000	20000	25000
Max. AC power(W)	9000	10000	12000	15000	17000	20000	25000
Max. AC current(A)	15	17	19	25	25	30	37
AC overcurrent protection(A)	42	42	42	54	54	60	72
Norminal AC output	50/60Hz; 400Vac						
AC output range	45~55Hz/55~65Hz; 310~480Vac						
THDi	<1.5%						
Power factor	0.9 leading~0.9 lagging						
Grid connection	3W/N/PE						
AC overvoltage category	Category III						
Current (inrush)	45A 75us						
Maximum output fault current	81.5A@27ms(L-L)/38.5A@5.7ms(L-N)						
Maximum output overcurrent protection	18.75	21.25	23.75	31.25	31.25	37.5	46.25
Efficiency							
Max. efficiency	98.0%	98.0%	98.0%	98.2%	98.2%	98.4%	98.4%
Euro efficiency	>97.7%	>97.7%	>97.7%	>97.7%	>97.7%	>98.1%	>98.1%
MPPT adaptation efficiency	99.9%	99.9%	99.9%	99.9%	99.9%	99.9%	99.9%
Protection							
Residual current monitoring unit	Integrated						
Anti-islanding protection	Integrated						
DC switch	Integrated (optional)						
AC over current protection	Integrated						
Insulation monitoring	Integrated						

Model	GW09K-DT	GW10K-DT	GW12K-DT	GW15K-DT	GW17K-DT	GW20K-DT	GW25K-DT
Certifications&Standards							
Grid regulation	VDE0126-1-1 ERDF-NOI- RES_13E	VDE-AR-N 4105 G59/3, EN50438 NRS097-2-1 AS4777.2&3 VDE0126-1-1 IEC62109-2 MEA, PEA, RD1699 ERDF-NOI-RES_13E	VDE-AR-N 4105, G59/3, NRS097-2-1 AS4777.2&3, IEC62109-2 VDE0126-1-1, RD1699, EN50438 ERDF-NOI-RES_13E	G59/3, EN50438 AS4777.2&3 VDE0126-1-1 IEC62109-2 MEA, PEA, RD1699 ERDF-NOI-RES_13E	VDE-AR-N 4105 G59/3		
Safety	IEC62109-1&-2, AS3100						
EMC	EN 61000-6-1,EN 61000-6-2,EN 61000-6-3,EN 61000-6-4, EN 61000-3-11, EN 61000-3-12						
General Data							
Dimensions (WxHxD)	516*650*203mm						
Weight (kg)	39	39	39	39	39	39	40
Mounting	Wall bracket						
Ambient temperature range	-25~60°C (>45°C derating)						
Relative humidity	0~95%						
Moisture location category	4K4H						
Max. operating altitude	2000m						
Protection degree	IP65						
Environment category	Outdoor & indoor						
External environment pollution degree	Grade1、 2、 3						
Topology	Transformerless						
Night power consumption(W)	<1						
Cooling	Fan cooling						
Noise emision(dB)	<45						
Display	5.0" LCD						
Communication	USB2.0; RS485 or WiFi						
Standard warranty(years)	5/10/15/20/25 (optional)						

Model	GW4000-DT	GW5000-DT	GW6000-DT
DC input Data			
* Max. DC power(W)	4200	5200	6200
Max. DC voltage (V)	1000	1000	1000
MPPT voltage range (V)	200~800	200~800	200~800
Starting voltage (V)	180	180	180
Max. DC current (A)	11/11	11/11	11/11
Max. inverter backfeed current to the array (A)	0		
DC overcurrent protection(A)	21	21	21
No. of DC connectors	2	2	2
No. of MPPTs	2 (can parallel)		
DC overvoltage category	Category II		
DC connector	MC4 / SUNCLIX (optional)		

Model	GW4000-DT	GW5000-DT	GW6000-DT
AC Output Data			
Normal AC power(W)	4000	5000	6000
Max. AC power(W)	4000	5000	6000
Max. AC current(A)	7	8.5	10
AC overcurrent protection(A)	22	28	28
Normal AC output	50/60Hz; 400Vac		
AC output range	45~55Hz/55~65Hz; 310~480Vac		
THDi	<1.5%		
Power factor	0.9 leading~0.9 lagging		
Grid connection	3W/N/PE		
AC overvoltage category	Category III		
Efficiency			
Max. efficiency	97.8%		
Euro efficiency	>96.7%		
MPPT adaptation efficiency	99.9%		
Protection			
Residual current monitoring unit	Integrated		
Anti-islanding protection	Integrated		
DC switch	Integrated (optional)		
AC over current protection	Integrated		
Insulation monitoring	Integrated		
Certifications&Standards			
Grid regulation	VDE-AR-N 4105, AS4777.2&3, IEC62109-2, VDE0126-1-1+A1, EN50438, G83/2		
Safety	IEC62109-1&-2, AS3100		
EMC	EN 61000-6-1, EN 61000-6-2, EN 61000-6-3, EN 61000-6-4, EN 61000-3-2, EN 61000-3-3		
General Data			
Dimensions (WxHxD)	516*474*192mm		
Weight (kg)	24		
Mounting	Wall bracket		
Ambient temperature range	-25~60°C (>45°C derating)		
Relative humidity	0~95%		
Moisture location category	4K4H		
Max. operating altitude	2000m		
Protection degree	IP65		
Environment category	Outdoor & indoor		
External environment pollution degree	Grade1、2、3		
Topology	Transformerless		
Night power consumption(W)	<1		
Cooling	Natural Convection		
Noise emission(dB)	<30		
Display	5.0" LCD		
Communication	USB2.0; RS485 or WiFi		
Standard warranty(years)	5/10/15/20/25 (optional)		

Model	GW4000L-DT	GW5000L-DT	GW6000L-DT
DC input Data			
* Max. DC power(W)	4200	5200	6200
Max. DC voltage (V)	600	600	600
MPPT voltage range (V)	200~550	200~550	200~550
Starting voltage (V)	180	180	180
Max. DC current (A)	11/11	11/11	11/11
Max. inverter backfeed current to the array (A)	0		
DC overcurrent protection(A)	21	21	21
No. of DC connectors	2	2	2
No. of MPPTs	2(can parallel)		
DC overvoltage category	Category II		
DC connector	MC4 / SUNCLIX (optional)		
AC Output Data			
Normal AC power(W)	4000	5000	6000
Max. AC power(W)	4000	5000	6000
Max. AC current(A)	7	8.5	10
AC overcurrent protection(A)	22	28	28
Normal AC output	50/60Hz; 400Vac		
AC output range	45~55Hz/55~65Hz; 310~480Vac		
THDi	<1.5%		
Power factor	0.9 leading~0.9 lagging		
Grid connection	3W/N/PE		
AC overvoltage category	Category III		
Efficiency			
Max. efficiency	96.8%		
Euro efficiency	>95.5%		
MPPT adaptation efficiency	99.9%		
Protection			
Residual current monitoring unit	Integrated		
Anti-islanding protection	Integrated		
DC switch	Integrated (optional)		
AC over current protection	Integrated		
Insulation monitoring	Integrated		
Certifications&Standards			
Grid regulation	AS4777.2&3, IEC62109-2		
Safety	IEC62109-1&-2, AS3100		
EMC	EN 61000-6-1, EN 61000-6-2, EN 61000-6-3, EN 61000-6-4, EN 61000-3-2, EN 61000-3-3		
General Data			
Dimensions (WxHxD)	516*474*192mm		
Weight (kg)	24		
Mounting	Wall bracket		

Model	GW4000L-DT	GW5000L-DT	GW6000L-DT
Relative humidity		0~95%	
Moisture location category		4K4H	
Max. operating altitude		2000m	
Protection degree		IP65	
Environment category		Outdoor & indoor	
External environment pollution degree		Grade1、2、3	
Topology		Transformerless	
Night power consumption(W)		<1	
Cooling		Natural Convection	
Noise emission(dB)		<30	
Display		5.0" LCD	
Communication		USB2.0; RS485 or WiFi	
Standard warranty(years)		5/10/15/20/25 (optional)	

*It is recommended that the total peak power of PV strings should not exceed 130% of maximum DC power of inverter listed in the table.

Note

Overvoltage category definition

Category I : applies to equipment connected to a circuit where measures have been taken to reduce transient overvoltage to a low level.

Category II : applies to equipment not permanently connected to the installation. Examples are appliances, portable tools and other plug-connected equipment;

Category III: applies to fixed equipment downstream of and including, the main distribution board. Examples are switchgear and other equipment in an industrial installation;

Category IV: applies to equipment permanently connected at the origin of an installation (upstream of the main distribution board). Example are electricity meters, primary overcurrent protection equipment and other equipment connected directly to outdoor open lines.

Moisture location category definition

Moisture parameters	Level		
	3K3	4K2	4K4H
Temperature Range	0~+40°C	-33~+40°C	-20~ +55°C
Humidity Range	5%~85%	15%~100%	4%~100%

Environment category definition

Outdoor : the ambient air temperature is -20~50°C, Relative humidity range is 4 % to 100 %, applied to PD3

Indoor unconditioned: the ambient air temperature is -20~50°C, Relative humidity range is 5 % to 95%,applied to PD3

Indoor conditioned: the ambient air temperature is 0~40°C, Relative humidity range is 5 % to 85%,applied to PD2

Pollution degree definition

Pollution degree 1: No pollution or only dry, non-conductive pollution occurs. The pollution has no influence.

Pollution degree 2: Normally only non-conductive pollution occurs. Occasionally, however, a temporary conductivity caused by condensation must be expected.

Pollution degree 3: Conductive pollution occurs, or, dry, non-conductive pollution occurs which becomes conductive due to condensation which is expected.

Pollution degree 4: Persistent conductive pollution occurs, for example, the pollution cause by conductive dust, rain and snow.

6.2 Block Diagram

Block Diagram of GW4000-DT~GW6000-DT and GW4000L-DT~GW6000L-DT refer to Figure 6.2-1:

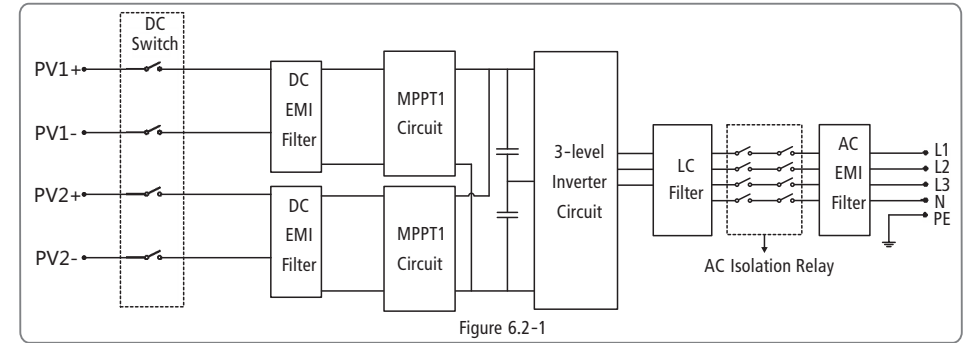

Block Diagram of GW09K-DT & GW10K-DT & GW12K-DT refer to Figure 6.2-2:

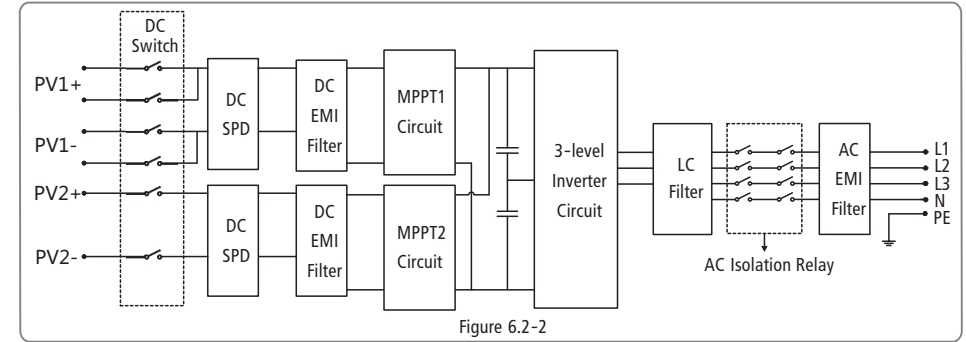

Block Diagram of GW15K-DT & GW17K-DT & GW20K-DT refer to Figure 6.2-3:

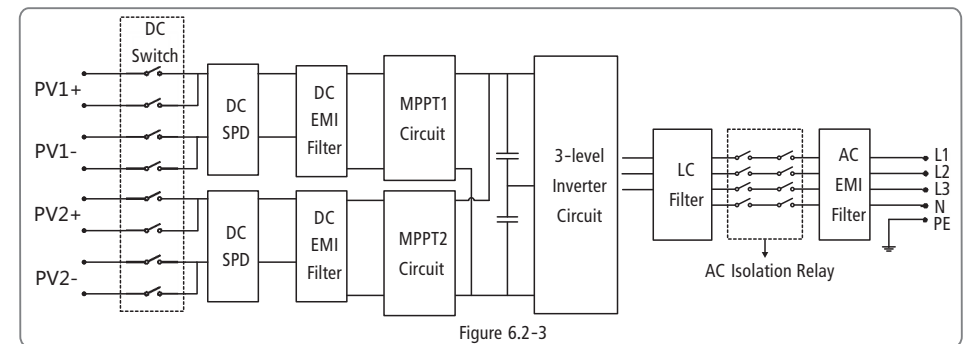

Block Diagram of GW25K-DT refer to Figure 6.2-4:

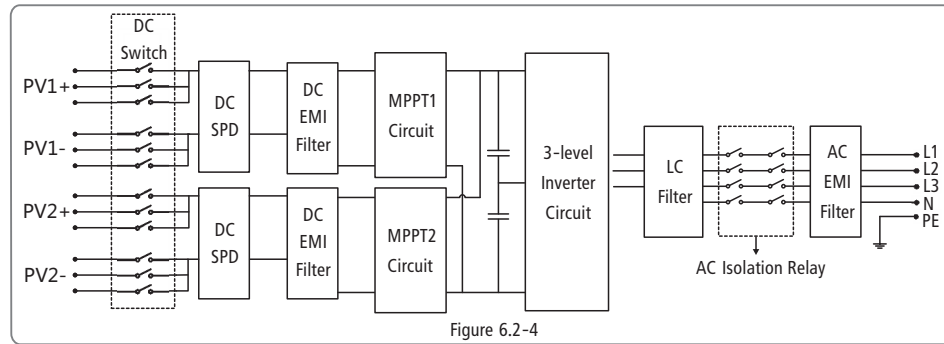

7 Maintenance

Regular maintenance ensures a long operating life and optimal efficiency of the entire PV plant.

Caution: Before maintains please disconnect the switch on AC and DC sides. Wait 10 seconds until the residual voltage has been drained.

7.1 Cleaning the Fans

DT series inverter is fitted with two fans on its left side. The fan intakes and handle covers should be cleaned yearly with a vacuum cleaner. For more thorough cleaning, completely remove the fans.

- Disconnect the switch on AC and DC sides.
- Wait 5 minutes until the residual voltage has been drained and the fans are no longer turning.
- Disassembly the fans (refer to Figure 7.1-1).
 - 1) Loosen the five M4 screws with a crosshead screwdriver, then remove the fans out the cabinet about 50mm slowly.
 - 2) Open the lockers of the two fan connectors and remove them from housing, then take the fans away.
- Clean the ventilation grid and the fan with a soft brush, a paint brush, a cloth, or compressed air.
- Reassembly the out fans into cabinet.

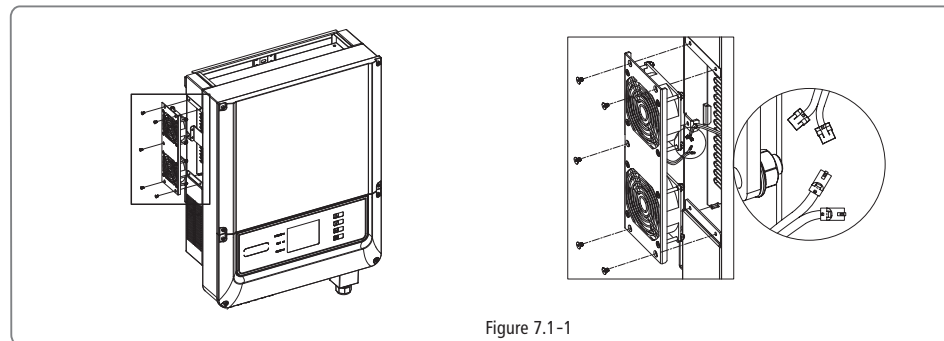

7.2 Checking the DC Switch

DC switch does not require any maintenance.

It is recommended, though not compulsory, to:

- Check the DC switch regularly.
- Activate the DC switch 10 times in a row once a year.

Operating the switch will clean the contacts and will extend the life of the DC switch.

8 Certificates

