



# User Manual

## SAJ Solar Inverter Suntrio Plus Series



[www.saj-electric.com](http://www.saj-electric.com)



## **Preface**

Thank you for choosing an SAJ solar inverter. We are pleased to provide you with first-class products and exceptional service.

This manual includes information for installation, operation, maintenance, trouble shooting and safety. Please follow the instructions of this manual so that we can ensure delivery of our professional guidance and wholehearted service.

Customer-orientation is forever our commitment. We hope this document proves to be of great assistance in your journey for a cleaner, greener world.

Please check for the latest version at [www.saj-electric.com](http://www.saj-electric.com)

Guangzhou Sanjing Electric Co., Ltd.

**Zero-Carbon Innovator**

## Content

Preface .....	- 1 -
Chapter 1 Safety Precautions .....	- 4 -
1.1 Scope of Application .....	- 4 -
1.2 Safety Instructions .....	- 4 -
1.3 Target Group .....	- 5 -
Chapter 2 Preparation .....	- 6 -
2.1 Safety Instructions .....	- 6 -
2.2 Explanations of Symbols .....	- 8 -
Chapter 3 Product Information .....	- 10 -
3.1 Application Scope of Products .....	- 10 -
3.2 Specification for Product Model .....	- 11 -
3.3 Overview and Dimensions of products .....	- 11 -
3.4 Datasheet .....	- 12 -
Chapter 4 Instructions for installation .....	- 14 -
4.1 Safety Instructions .....	- 14 -
4.2 Pre-installation Check .....	- 14 -
4.3 The Determination of the Installation Method and Position .....	- 16 -
4.4 Mounting Procedure .....	- 18 -
Chapter 5 Electrical Connection .....	- 20 -
5.1 Safety Instruction for Hot-line Job .....	- 20 -
5.2 Specifications for Electrical Interface .....	- 21 -
5.3 AC Side Connection .....	- 21 -
5.4 DC Side Connection .....	- 23 -
5.5 Communication Connection .....	- 26 -
Chapter 6 Debugging Instructions .....	- 27 -

6.1 Introduction of Human-computer Interface .....	- 27 -
6.2 First Run Setup.....	- 28 -
6.3 Monitoring Operation.....	- 36 -
Chapter 7 Fault Code and Troubleshooting.....	- 37 -
Chapter 8 Recycling and Disposal .....	- 40 -
Chapter 9 Guarantee Service .....	- 41 -
Chapter 10 Contact SAJ .....	- 42 -

# Chapter 1 Safety Precautions

## 1.1 Scope of Application

This User Manual describes instructions and detailed procedures for installing, operating, maintaining, and troubleshooting of the following SAJ grid-tie inverters:

Suntrio Plus 4K; Suntrio Plus 5K; Suntrio Plus 6K;

Suntrio Plus 8K; Suntrio Plus 10K

Please keep this manual all time available in case of emergency.

## 1.2 Safety Instructions

**DANGER**

· DANGER indicates a hazardous situation which, if not avoided, will result in death or serious injury.

**WARNING**

· WARNING indicates a hazardous situation which, if not avoided, can result in death or serious injury or moderate injury.

**CAUTION**

· CAUTION indicates a hazardous condition which, if not avoided, can result in minor or moderate injury.

**NOTICE**

· NOTICE indicates a situation that can result in potential damage, if not avoided.

### **1.3 Target Group**

Only qualified electricians who have read and fully understood all safety regulations contained in this manual can install, maintain and repair the inverter. Operators must be aware of the high-voltage device.

## Chapter 2 Preparation

### 2.1 Safety Instructions



#### DANGER

- Dangerous due to electrical shock and high voltage.
- Do not touch the operating component of the inverter, it might result in burning or death.
- To prevent risk of electric shock during installation and maintenance, please make sure that all AC and DC terminals are plugged out.
- Do not touch the surface of the inverter while the housing is wet, it might lead to electrical shock.
- Do not stay close to the inverter while there are severe weather conditions including storm, lighting, etc.
- Before opening the housing, the SAJ inverter must be disconnected from the grid and PV generator; you must wait at least five minutes to let the energy storage capacitors fully discharged after disconnecting from power source.



#### WARNING

- The installation, service, recycling and disposal of the inverters must be performed by qualified personnel only in compliance with national and local standards and regulations.
- Any unauthorized actions including modification of product functionality of any form may cause lethal hazard to the operator, third parties, the units or their property. SAJ is not responsible for the loss and these warranty claims.
- The SAJ inverter must only be operated with PV generator. Do not connect any other source of energy to the SAJ inverter.
- Be sure that the PV generator and inverter are well grounded in order to protect properties and persons.



#### CAUTION

- The PV inverter will become hot during operation. Please do not touch the heat sink or peripheral surface during or shortly after operation.
- Risk of damage due to improper modifications.
- Risk of damage due to improper modifications.











**NOTICE**

·Public utility only

·The PV inverter is designed to feed AC power directly to the public utility power grid; do not connect AC output of the inverter to any private AC equipment.



## 2.2 Explanations of Symbols

Symbol	Description
	<b>Dangerous electrical voltage</b> This device is directly connected to public grid, thus all work to the inverter shall only be carried out by qualified personnel.
	<b>DANGER to life due to high electrical voltage!</b> There might be residual currents in inverter because of large capacitors. Wait 5 MINUTES before you remove the front lid.
	<b>NOTICE, danger!</b> This is directly connected with electricity generators and public grid.
	<b>Danger of hot surface</b> The components inside the inverter will release a lot of heat during operation. Do not touch metal plate housing during operating.
	<b>An error has occurred</b> Please go to Chapter 9 “Troubleshooting” to remedy the error.
	<b>This device SHALL NOT be disposed of in residential waste</b> Please go to Chapter 8 “Recycling and Disposal” for proper treatments.
	<b>Without Transformer</b> This inverter does not use transformer for the isolation function.
	<b>Security Certificate</b> The inverter complies with European product safety instructions.
	<b>CE Mark</b> Equipment with the CE mark fulfills the basic requirements of the Guideline Governing Low-Voltage and Electro-magnetic Compatibility.
	<b>SAA Mark</b> The inverter complies with the requirement of Equipment and Product Safety Act in Australia.

 <p>The logo for China's Quality Center (CQC) is circular with a blue border. Inside, there's a yellow sun-like symbol and the letters 'CQC' in blue. Chinese characters are written around the inner border.</p>	<p><b>CQC Mark</b> The inverter complies with the safety instructions from China's Quality Center.</p>
<p><b>ATTENTION!</b> ⚠ Risk of electric shock! Only authorized personnel are allowed to do disassembly, modification or maintenance. Any resulting defect or damage (device/person) is not covered by SAJ guaranty.</p>	<p><b>No unauthorized perforations or modifications</b> Any unauthorized perforations or modifications are strictly forbidden, if any defect or damage (device/person) is occurred, SAJ shall not take any responsibility for it.</p>

## Chapter 3 Product Information

### 3.1 Application Scope of Products

Suntrio Plus series products are grid-tie single phase inverters without transformers, and the inverters are important components of grid-tie solar power systems.

The Suntrio Plus inverters change the DC generated by solar panels into AC which is in accordance with the requirements of public grid, and send the AC into the grid, Table 3.1 shows the structural diagram of the typical application system of Suntrio Plus inverters.

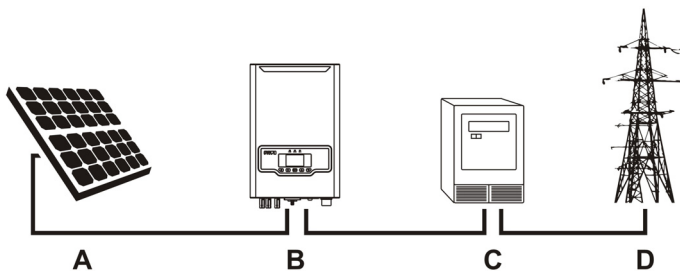

Name	Description	Remarks
A	Solar panels	Monocrystalline or polycrystalline silicon, and thin-film PV modules with II protection and need no ground connection
B	Inverters	Suntrio Plus 4K/5K/6K/8K/10K
C	Metering equipment	Standard metering tool for measuring the output electric power of inverters
D	Power grid	TT, TN-C, TN-S, TN-C-S

Table 3.1 Systematic Configuration Diagram

### 3.2 Specification for Product Model

#### Suntrio Plus XK

①                      ②

① Suntrio Plus represents for product name.

② XK represents rated power XkW of inverter, for example 5K means 5kW.

### 3.3 Overview and Dimensions of products

The dimensions of Sununo Plus series products is shown in Figure 3.2.

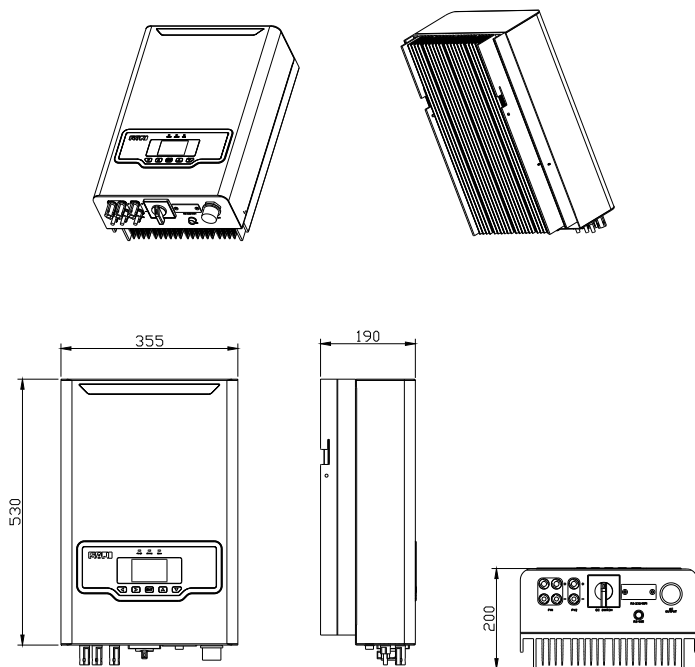

Figure 3.2 Dimensions of Suntrio Plus 4K/5K/6K/8K/10K

### 3.4 Datasheet

#### Suntrio Plus 4K/5K/6K/8K/10K

Type	Suntrio Plus 4K	Suntrio Plus 5K	Suntrio Plus 6K	Suntrio Plus 8K	Suntrio Plus 10K
<b>Input (DC)</b>					
Max. DC Power [W]	4200	5300	6300	8400	10500
Max. DC Voltage [V]	1000				
MPPT Voltage Range [V]	160-900				
Nominal DC Voltage [V]	600				
Start Voltage[V]	180				
Min. DC Voltage[V]	150				
Max. DC Input Current PV1 / PV2 [A]	11/11			22/11	
Number of MPPT	2				
Number of DC Connection Sets per MPPT	1/1			2/1	
DC Switch	Integrated				
<b>Output (AC)</b>					
Rated AC Power [VA] (@230V,50Hz)	4000	5000	6000	8000	10000
Max. AC Apparent Power [VA]	4000	5000	6000	8000	10000
Rated AC Current[A]	5.8	7.2	8.7	11.6	14.5
Max. AC Current [A]	6.4	8.1	9.7	12.9	15.9
Nominal AC voltage/ range	3/N/PE, 220/380V,230/400V,240/415V;180V-280V/312V-485V				
Grid frequency/ range	50Hz,60Hz /44Hz-55Hz,54-65Hz				
Power factor,adjustable	0.9 leading-0.9 lagging				
Total Harmonic Distortion (THDi)	< 3% (at nominal power)				
Feed-in Phase / Connection Phase	3 /3				
<b>Efficiency</b>					
Max. Efficiency	97.8%	97.8%	97.8%	98.0	98.0
Euro Efficiency (at 600Vdc)	97.0%	97.2%	97.4%	97.5	97.6
MPPT Accuracy	>99.5%				
<b>Protection</b>					
Internal Over-voltage Protection	Integrated				
DC Insulation Monitoring	Integrated				
DCI Monitoring	Integrated				
GFCI Monitoring	Integrated				

Grid Monitoring	Integrated	
AC Short Circuit Current Protection	Integrated	
Thermal Protection	Integrated	
Anti-island protection monitoring	AFD	
<b>Interface</b>		
DC Connection	MC4/H4	
AC Connection	Plug-in connector	
LCD Display	3.5 inch Graphic LCD Display, Backlight, Inverter Parameter and Data Display	
Display Language	Multi Language	
Datalogger & Communication	1*RS485/1*RS232/WiFi(Optional)	
<b>General Data</b>		
Topology	Transformerless	
Consumption at Night [W]	<0.6	
Consumption at Standby [W]	<10	
Operating Temperature Range	-25°C to +60°C(45°C to 60°C with derating)	
Cooling Method	Natural Convection	
Ambient Humidity	0% to 100% Non-condensing	
Altitude	Up to 2000m (without power derating)	
Noise [dBA]	<29	
Ingress Protection	IP65 (Indoor & Outdoor Installation)	
Mounting	Rear Panel	
Dimensions (H*W*D) [mm]	530*355*190	530*355*200
Net Weight [kg]	22	24.6
Standard Warranty [Year]	5 (standard)/10/15/20/25 (Optional)	
Certificates	IEC62109-1/2, IEC61000-6-2/3, IEC61683, IEC60068-2, IEC62116, IEC61717, PEA/MEA, NRS 097-2-1, UTE-C-15-712-1, VDE0126-1-1/A1, VDE-AR-N 4105, AS4777.2, AS4777.3, C-TICK, CQC NB/T 32004, G83-2,NBR 16149, NBR 16150, TF 3.2.1	

## Chapter 4 Instructions for installation

### 4.1 Safety Instructions

**DANGER**

- Dangerous to life due to potential fire or electricity shock.
- Do not install the inverter near any inflammable or explosive items.
- This inverter will be directly connected with HIGH VOLTAGE power generation device; the installation must be performed by qualified personnel only in compliance with national and local standards and regulations.

**NOTICE**

- This equipment is suit for the pollution degree II.
- Inappropriate or the harmonized installation environment may jeopardize the life span of the inverter.
- Installation directly exposed under intensive sunlight is not recommended.
- The installation site must have good ventilation condition.

### 4.2 Pre-installation Check

#### 4.2.1 Check the Package

Although SAJ's inverters have surpassed stringent testing and are checked before they leave the factory, it is possible that the inverters may suffer damages during transportation. Please check the package for any obvious signs of damage and if such evidence is present, do not open the package and contact your dealer as soon as possible.

### 4.2.2 Check the Assembly Parts

After opening the package, please refer to Table 4.1 and 4.2 to check the completeness of the assembly parts. Please contact your dealer if anything is damaged or missing.











			
<b>A</b>	<b>B</b>	<b>C</b>	<b>D</b>
			
<b>E</b>	<b>F</b>	<b>G</b>	<b>H</b>
			
<b>I</b>	<b>J</b>		

Table 4.1 Assembly Parts List

Sequence Number	Name	Quantity	Unit	Remarks
A	Inverter	1	Set	
B	Rear Panel	1	piece	
C	DC connector	2	Pair	Suntrio Plus 4K/5K/6K
		3		Suntrio Plus 8K/10K
D	RS485 Connector	1	piece	
E	M6×50 hex head screw	3	piece	
F	Expansion tube	3	piece	
G	M5×12 hex head screw and gasket	2	piece	
H	AC connector	1	piece	
I	User Manual	1	Copy	
J	Warranty card	1	Copy	

Table 4.2 Quantity of Assembly Parts and Instructions



## 4.3 The Determination of the Installation Method and Position

### 4.3.1 Mounting Method

Please mount the inverter rightly as shown in Figure4.1 below.

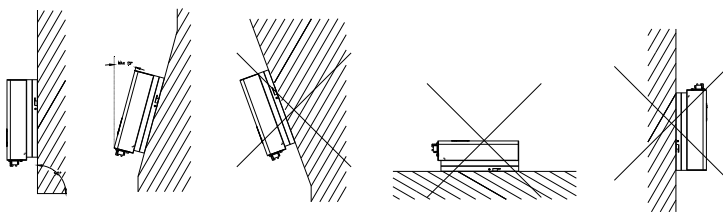

Figure 4.1 Mounting Method

- ① The equipment employs natural convection cooling, and it can be installed indoor or outdoor.
- ② Please install the equipment under the guidance of Figure4.1. Vertical installation on floor level is recommended. Mount vertically or tilted backwards by max. 15°. Never install the inverter tilted forward, sideways, horizontally or upside down.
- ③ Install the inverter at eye level for convenience when checking the LCD display and possible maintenance activities.
- ④ When mounting the inverter, please consider that disassembly for service work may be required.

### 4.3.2 Installation Position

Do not expose the inverter to direct solar irradiation as this could cause power derating due to overheating. The ambient temperature should be between  $-25^{\circ}\text{C} \sim +60^{\circ}\text{C}$  ( $-13^{\circ}\text{F} \sim 140^{\circ}\text{F}$ ) to ensure optimum operation. Choose locations with sufficient air exchange. Ensure additional ventilation, when necessary.

To make sure the installation spot is suitably ventilated, if multiple SAJ grid-tie solar inverters are installed in the same area, the following safety clearance in Figure 4.2 shall be followed for appropriate ventilation conditions.

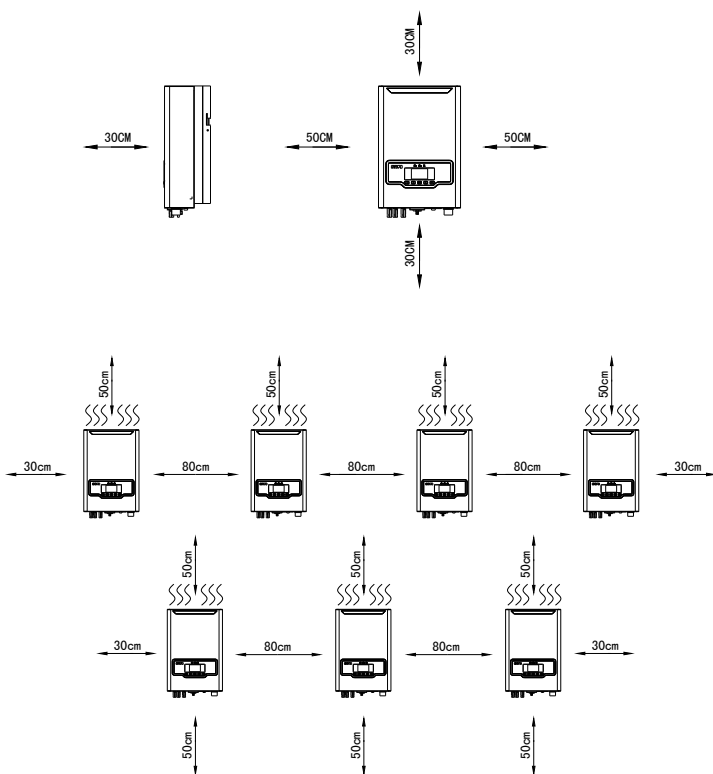

Figure 4.2 Minimum Clearance

## 4.4 Mounting Procedure

### 4.4.1 Mark the Positions of the Drill Holes of the Rear Panel

The position of the drill holes can be determined by using rear panel. See Figure 4.3 below:

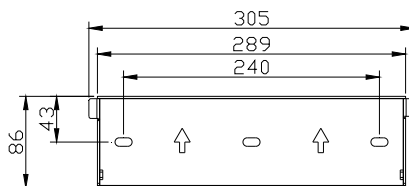

Figure 4.3 Dimensions of Rear Panel

### 4.4.2 Drill Holes and Place the Expansion Tubes

According to the guides, drill 3 holes in the wall as shown in Figure 4.4 (in conformity with position marked in the above mentioned figure), and then place expansion tubes in the holes using a rubber mallet.

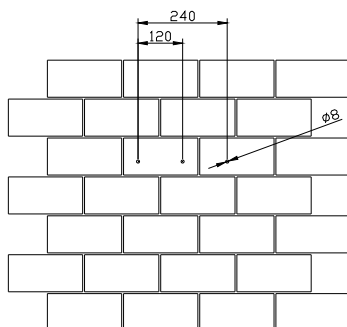

Figure 4.4 Drill Holes

#### 4.4.3 Mount the Screws and the Rear Panel

The panels should be mounted in the mounting position by screws as shown in Figure 4.5.

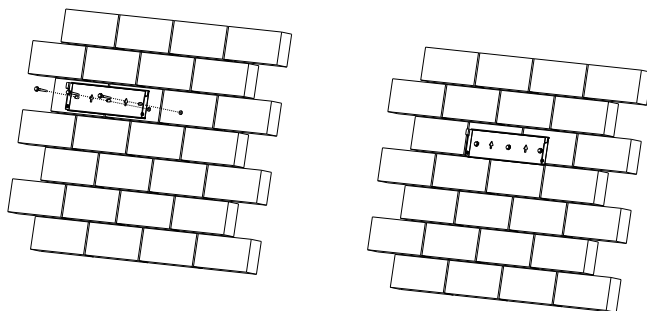

Figure 4.5 Mount the Rear Panel

#### 4.4.4 Mount the Inverter

Carefully mount the inverter to the rear panel. Make sure that the rear part of the equipment is closely mounted to the rear panel.

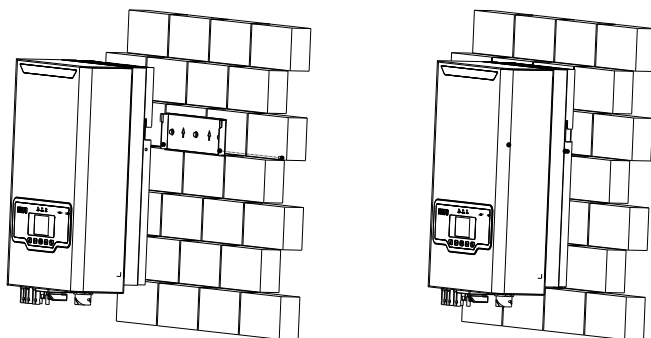

Figure 4.6 Mount the Inverter

## Chapter 5 Electrical Connection

### 5.1 Safety Instruction for Hot-line Job

Electrical connections must only be operated on by professional technicians. Please keep in mind that the inverter is a bi-power supply equipment. Before connection, necessary protective equipment must be employed by technicians including insulating gloves, insulating shoes and safety helmet.



#### DANGER

- Dangerous to life due to potential fire or electricity shock.
- When power-on, the equipment should in conformity with national rules and regulations.
- The direct connection between the converter and high voltage power systems must be operated by qualified technicians in accordance with local and national power grid standards and regulations.



#### WARNING

- When the photovoltaic array is exposed to light, it supplies a d.c voltage to the inverter.



#### NOTICE

- Electrical connection should in conformity with proper stipulations, such as stipulations for cross-sectional area of conductors, fuse and ground protection.
- The overvoltage category on DC input port is II,on AC output port is III.

## 5.2 Specifications for Electrical Interface

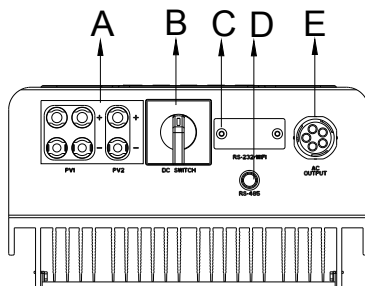

Figure 5.1 Electrical Interface

Code	Name
A	DC Input
B	DC Switch
C	RS232/Wi-Fi Port
D	RS485 Port
E	AC Quick-connect Terminal

Table 5.1 Specifications for Interface

## 5.3 AC Side Connection

Cross-sectional Area of Cables (mm <sup>2</sup> )		Outside Diameter of the Cables (mm)
Scope	Recommended Value	
4.0-6.0	6.0	4.2~5.3

Table 5.2 Recommended Specifications of AC Cables

### 5.3.1 Feed the AC Cable Through the AC Waterproof hole.

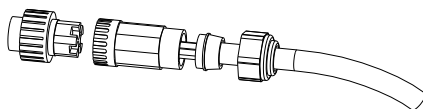

Figure 5.2 Feed the cables

### 5.3.2 Connect the cables according to connection marks of L1,L2,L3,N and PE.

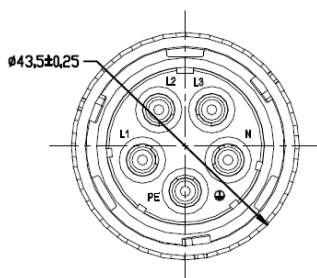

Figure 5.3 Connect the Cables

### 5.3.3 Secure all Parts of the AC Connector Tightly.

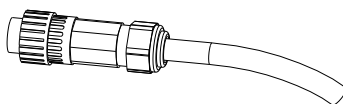

Figure 5.4 Screw the Connector

**5.3.4 Plug in the AC connector to the equipment securely, ensuring the pins are connected directly. Then the connection of AC cable is complete.**

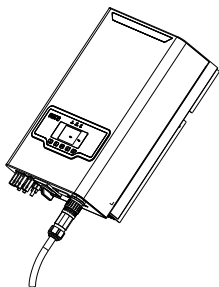

Figure 5.5 Connect the Inverter

## 5.4 DC Side Connection

Cross-sectional Area of Cables (mm <sup>2</sup> )		Outside Diameter of the Cables (mm)
Scope	Recommended Value	
4.0-6.0	4.0	4.2~5.3

Table5.3 Recommended Specifications of DC Cables

**DC connector is made up of the positive connector and the cathode connector**

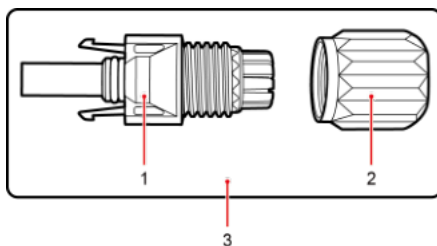

1. Insulated Enclosure

2. Lock Screw

3. Positive Connector

Figure 5.6 Positive Connector



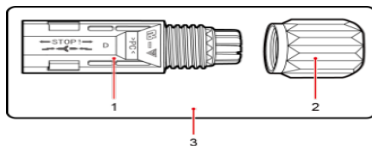

1. Insulated Enclosure    2. Lock Screw    3. Cathode Connector

Figure 5.7 Cathode Connector

### NOTICE

·Please place the connector separately after unpacking in order to avoid confusion for connection of cables.

·Please connect the positive connector to the positive side of the solar panels, and connect the cathode connector to the cathode side of the solar side. Be sure to connect them in right position.

### Connecting Procedures:

- (1) Tighten the lock screws on positive and cathode connector.
- (2) Use specified strip tool to strip the insulated enclosure of the positive and cathode cables to the appropriate length.

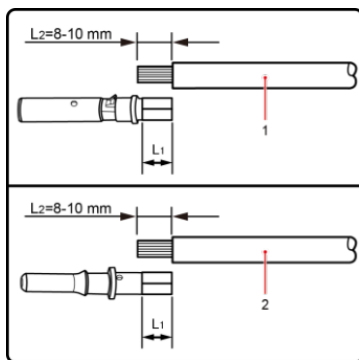

1. Positive Cable

2. Cathode Cable

Figure 5.8 Connecting Cables

- (3) Feed the positive and cathode cables into corresponding lock screws.
- (4) Put the metal positive and cathode terminals into positive cable and cathode cable whose insulated enclosure has been stripped, and crimp them tightly with a wire crimper. Make sure that the withdrawal force of the pressed cable is bigger than 400N.
- (5) Plug the pressed positive and cathode cables into relevant insulated enclosure, a “click” should be heard or felt when the contact cable assembly is seated correctly.
- (6) Fasten the lock screws on positive and negative connectors into respondent insulated enclosure and make them tight.
- (7) Connect the positive and cathode connectors into positive and negative DC input terminals of the inverter, a “click” should be heard or felt when the contact cable assembly is seated correctly.

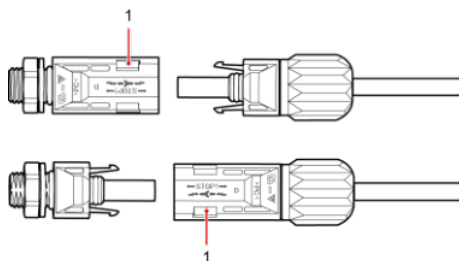

### 1. Connection Port

Figure 5.9 Connect the Inverter

#### **!** NOTICE

·Before insert the connector into DC input terminal of the inverter, please make sure that the DC switch of the inverter is OFF.

## 5.5 Communication Connection

Suntrio Plus 4K/5K/6K/8K/10K is equipped with an RS232 and an RS485 interface.

(1) Connect the Wi-Fi modules with the interfaces of RS232 and tighten the screws. Please refer to Wi-Fi manual for detailed information.

(2) The USB interface for RS232 is displayed in the picture below. Connect the inverter with computer and the information of the inverter can be monitored via your internet browser.



Figure 5.10 Nine Serial Port Cable

When using RS485 for monitoring, multi-point monitoring can be achieved by connecting the inverter with RS485 cables. Each connection port should be attached to the connector as shown in Figure 5.11 and Table 5.4. Make sure the connection is tight and secure.

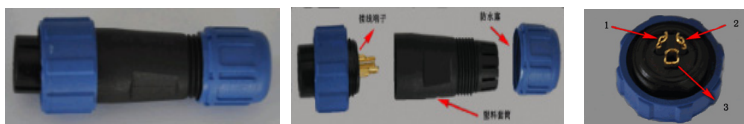

Figure 5.11 Three Ports Connector

Number of Connector	Color of Cables
1	Blue and white
2	Blue
3	Metal-shielded wire

Table 5.3 Assembly Sequence of RS485

## Chapter 6 Debugging Instructions

### 6.1 Introduction of Human-computer Interface

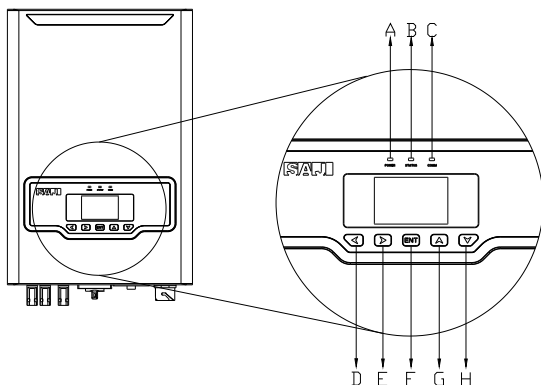

Figure 6.1 Human-computer Interface

Object	Description
A	Power indicator light: yellow light: the power system of inverter is operating normally
B	Status indicator lamp: Red LED light = Fault; Green LED light = operation; when red and green light are all off, the inverter is in initializing state or countdown for
C	Communication light: blue light flashing = receiving data yellow light flashes = sending data
D ◀	Moves the cursor or the focus point to the left
E ▶	Moves the cursor or the focus point to the right
F	Starts the menu / button to confirm selection
G ▲	Moves the cursor up or increases the setting value
H ▼	Moves the cursor down or reduces the setting value

The inverter provides five buttons for inquiry of operational information and parameters, these five buttons can be used repeatedly.

## 6.2 First Run Setup

### 6.2.1 Set The Country

When the solar inverter begins to run for the first time, please configure the time of usage, and the inverter LCD will display as below:

Graph	Setting	Run-Info	About
Please Set Time & Date			
Date	09/23/2015		Power 0 W
Times	13:23:56		E-Today 0.00 kWh
	Ok	Return	E-Total 0.00 kWh
			T-Today 0.0 h
			T-Total 0.0 h
Init	Set system Time	15-06-09	15: 47

Figure 6.2 Set the Time

Users can press Up, Down, Left, Right and ENT buttons to set local time and confirm the selection. Then the inverter will display the interface for country selection as shown in Figure 6.3:

Graph	Setting	Run-Info	About
Country	Australia	Please set grid country	Power 0 W
	Australia		E-Today 0.00 kWh
	Belgium		E-Total 0.00 kWh
	Brazil		T-Today 0.0 h
	Denmark		T-Total 0.0 h
	Finland		
	France		
	Luxembourg		
	Netherlands		
Init	Grid Compliance	15-06-09	15: 47

Figure 6.3 Set The Country

Please press the "ENT" button, LCD will show the countries for option. Users can press "▼" or "▲" to select the correct country and press "ENT" button to confirm the selection.

**Note:** The configuration of the country of usage must be set before inverter starts to run for its first time, otherwise the inverter will not on-grid. If users can not locate the corresponding country, please abort the setting and contact the after sales for confirmation.

## 6.2.2 State

If the country has been set the LCD shows the machine type when the inverter is started up, then it automatically displays the inverter operation status: Initialization, Normal, Wait, Fault or Update.

Data name	Explanation
Initialization	Initialization of the system
Normal	The inverter in normal (function) operation
Wait	The inverter in stand-by state
Fault	A fault occurs during operation
Update	The state of updating firmware

Turn on the AC switch, the LCD begins to count backwards, after this, the inverter initiates connection to the grid.

## 6.2.3 LCD Menu

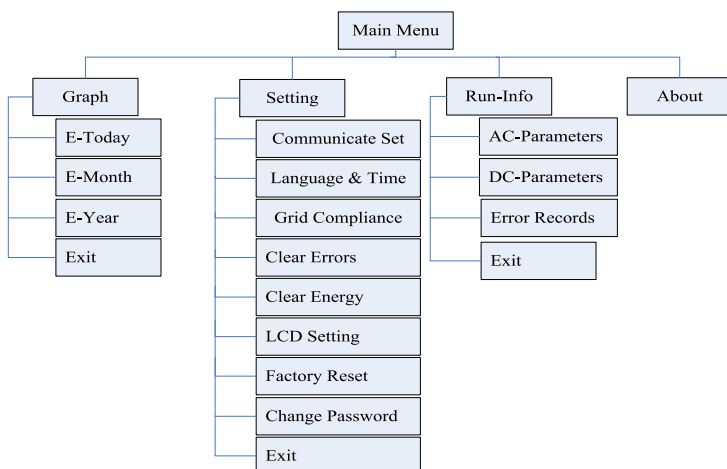

Figure 6.4 LCD Menu

## 6.2.4 Settings of General Parameters of the Inverter

LCD Display		Operation Steps
<b>1. Settings of figures</b>		
Graph Set		<p>In the main LCD interface, press “ENT” button to enter into the selection of “Figure”, press ▼ or ▲ to select. The LCD displays daily, monthly, yearly and gross generating capacity.</p>
<b>2. Settings of System Parameter</b>		
Communicate Set		<p>1. In the main LCD interface, press “ENT” button, then press ► to enter into “Setting”.</p>
		<p>2. Press ENT to enter into” Communication Settings”. Press ▼ and ▲ to set the communication address of Wi-Fi and RS485. The Fault address is 1.</p>

Language & Time		<p>1. In the main LCD interface, press “ENT” button, then press <b>▶</b> to enter into “Setting”.</p>
		<p>2. Press <b>▼</b> and then press ENT to enter into “Language &amp; Time”. Press <b>▲</b> and <b>▼</b> to set the language, date and time.</p>
Grid Compliance		<p>1. In the main LCD interface, press “ENT” button, then press <b>▶</b> to enter into “Setting”.</p>
		<p>2. Press <b>▼</b> and then press ENT to enter password and enter into country setting.</p>



		<p>3. Press ▲ and ▼ to select country, Then click OK to save the changes.</p>
Clear Errors		<p>1. In the main LCD interface, press “ENT” button, then press ► to enter into “Setting”.</p>
		<p>2. Press ▼ and then press ENT to enter into “Clear Fault Records”, click OK or return back.</p>
Clear Energy		<p>1. In the main LCD interface, press “ENT” button, then press ► to enter into “Setting”.</p>

		<p>2. Press ▼ and then press ENT to enter into “Clear Energy”, click OK or return back.</p>
LCD Setting		<p>1. In the main LCD interface, press “ENT” button, then press ► to enter into “Setting”.</p>
		<p>2. Press ▼ and then press ENT to enter into “Display Settings”, and then press ▲ and ▼ to change the sleep time of LCD, click OK or return back.</p>
		<p>1. In the main LCD interface, press “ENT” button, then press ► to enter into “Setting”.</p>

Factory Reset		2. Press ▼ and then press ENT to enter password, and then enter into Factory Settings.
		3. Click OK to save the changes.
Change Password		1. In the main LCD interface, press “ENT” button, then press ► to enter into “Setting”.
		2. Press ▼ and then press ENT to enter password, and then enter into Reset Password.

Graph	Setting	Run-Info	About
Please enter the new password:			Power 1230W
<input type="text"/> <input type="text"/> <input type="text"/> <input type="text"/> <input type="text"/> <input type="text"/>			E-Today 11.33 kWh
<input type="button" value="Ok"/> <input type="button" value="Cancel"/>			E-Total 14.35 kWh
			T-Today 1.7 h
			T-Total 4.6 h
Normal	Chang Password	15-07-09	15: 47

3. Enter the new password and click OK to save the change.

## 6.2.5 Inquiry of Parameters of Inverter

### 1. Inquiry of Operating Parameters

Graph	Setting	Run-Info	About
		AC-Parameters DC-Parameters Error-Records Exit	Power 1230W
			E-Today 11.33 kWh
			E-Total 14.35 kWh
			T-Today 1.7 h
			T-Total 4.6 h
Normal	E-Today 11.33 kWh	15-07-09	15: 47

1. In the main LCD interface, press “ENT” button, then press **▶** to enter into “Parameters”.

2. Press ENT to enter into “Run-Info”, then press **▼** or **▲** to select the needed parameters, press ENT to enter and to check the parameters.

### 2. Inquiry of the Information of Inverter

Graph	Setting	Run-Info	About
			Power 1230W
			E-today 11.33 kWh
			E-Total 14.35 kWh
			T-Today 1.7 h
			T-Total 4.6 h
Normal	E-Today 11.33 kWh	15-07-09	15: 47

1. In the main LCD interface, press “ENT” button, then press **▶** to enter into “About”.

2. Press ENT to enter into “About” to check the equipment type, series number, machine code, software version of display panel, mainframe version of the control panel and the settings of country.

## 6.3 Monitoring Operation

The equipment is equipped with an RS232 and an RS485 interface, and the RS232 interface can be connected to Wi-Fi modules or USB interface which can be used in the monitoring of the operation status.

- ① The equipment can be connected to local internet via a Wi-Fi module and the SAJ web server which is embedded in the machine, following this, the operational status of the inverter can be monitored.
- ② By connecting the internet through a Wi-Fi module and uploading the data of the inverter to server, users can monitor the operational information of the inverter by web version web portal or mobile APP (please download the mobile APP from SAJ's official website) remotely.
- ③ Connecting the inverter to computer by nine-serial port cable, the operational information of the inverter can be read by the appropriate computer software.
- ④ Users can apply a Modbus protocol through RS485 together with an SAJ Logger to monitor the data of the inverter. For detailed operation please refer to the SAJ Logger User Manual.

## Chapter 7 Fault Code and Troubleshooting

LCD displays Fault codes as shown in the table below:

Error Code	Explanation
01	Relay Error Master
02	Storer Error Master
03	High Temperature Master
04	Low Ttemperature Master
05	Interior Communication Master
06	GFCI Devices Error Master
07	DCI Devices Error Master
08	Current Sensor Master
09/11/13	L1/L2/L3 Voltage High Master
10/12/14	L1/L2/L3 Voltage Low Master
15/16/17	L1/L2/L3 Average Voltage of 10 mimutes High Master
18/20/22	L1/L2/L3 Frequency High Master
19/21/23	L1/L2/L3 Frequency Low Master
24/25/26	L1/L2/L3 Grid Lost Error Master
27	GFCI Error Master
28/29/30	L1/L2/L3 DCI Error Master
31	Insulation Error Master
32	Bus Voltage unbalance Master
33	Bus Voltage High Master
34	Bus Voltage Low Master
35/36/37	L1/L2/L3 Current High Master
38	Bus Voltage High Of Hardware Master
39/40	PV1/PV2 Current High of Hardware Master
41/42/43	L1/L2/L3 Current High of Hardware of Grid Master
45/46/47/48	Fan 1/2/3/4 Error Master
50	Lost interior communication Slave
51/52/53	L1/L2/L3 Data Consistency of Voltage Error Slave
54/55/56	Data Consistency of Frequency Error Slave

57	Data Consistency of GFCI Slave
58/59/60	L1/L2/L3 Data Consistency of DCI Slave
61/63/65	L1/L2/L3 Grid Voltage High Slave
62/64/66	L1/L2/L3 Grid Voltage Low Slave
67/69/71	L1/L2/L3 Frequency High Slave
68/70/72	L1/L2/L3 Frequency Low Slave
73/74/75	L1/L2/L3 No Grid Error Slave
76/77	PV1 /PV2 Voltage High Slave
78/79	PV1/PV2 current High Slave

Table7.1 Error Code

**General troubleshooting methods for inverter are as follows:**

<b>Fault Information</b>	<b>Troubleshooting</b>
Relay Error	If this error occurs frequently, please contact your distributor or phone SAJ.
Eeprom Error	If this error occurs frequently, please contact your distributor or phone SAJ.
Temperature High Error	Check whether the radiator is blocked, whether the inverter is in too high or too low temperature, if the above mentioned are in normal, please contact your distributor or phone SAJ.
GFCI Device Error	If this error occurs frequently, please contact your distributor or phone SAJ.
DCI Device Error	If this error occurs frequently, please contact your distributor or phone SAJ.
Current Sensor Error	If this error occurs frequently, please contact your distributor or phone SAJ.
AC Voltage Error	<ul style="list-style-type: none"> <li>·Check the volt of the grid</li> <li>·Check the connection between the inverter and the grid.</li> <li>·Check the settings of the on-grid standards of the inverter.</li> <li>·If the volt of the grid is higher than the volt regulated by local grid, please inquire the local grid workers whether they can adjust the volt at the feed point or change the value of the regulated volt.</li> <li>·If the volt of the grid is in regulated range as allowed and LCD still in this error, please contact your distributor or phone SAJ.</li> </ul>

Frequency Error	Check the set of country and check the frequency of the local grid, if the above mentioned are in normal, please contact your distributor or phone SAJ.
No Grid Error	Check the connection status between the AC side of the inverter and the grid, if the above mentioned are in normal, please contact your distributor or phone SAJ.
GFCI Error	Check the insulation resistance of the positive side and cathode side of the solar panel; check whether the inverter is in wet environment; check the grounding of the inverter. If the above mentioned are in normal, please contact your distributor or phone SAJ.
DCI Error	If this error exists always, please contact your distributor or phone SAJ.
ISO Error	Check the insulation resistance of the positive side and cathode side of the solar panel; check whether the inverter is in wet environment; check whether the grounding of the inverter is loose or not. If the above mentioned are in normal, please contact your distributor or phone SAJ.
Current High	Check the connection status between the inverter and the grid and test whether the volt of the grid is stable or not, if the above mentioned are in normal, please contact your distributor or phone SAJ.
Bus Voltage High	Check the settings of the solar panel. SAJ's system design software can help you. If the above mentioned are in normal, please contact your distributor or phone SAJ.
PV Current High	If this error exists always, please contact your distributor or phone SAJ.
PV Voltage Fault	Check the settings of the solar panel. SAJ's system design software can help you. If the above mentioned are in normal, please contact your distributor or phone SAJ.
Lost Communication	Check the connection of communication cables between control panel and display panel. If the above mentioned are in normal, please contact your distributor or phone SAJ.

Table 7.2 Troubleshooting



## **Chapter 8 Recycling and Disposal**

This device should not be disposed as residential waste. An Inverter that has reached the end of its life and is not required is to be returned to your dealer or you must find an approved collection and recycling facility in your area.

## **Chapter 9 Guarantee Service**

Please refer to the warranty card.

## **Chapter 10 Contact SAJ**

### **Guangzhou Sanjing Electric Co., Ltd.**

SAJ Innovation Park, No.9, Lizhishan Road, Guangzhou Science City, Guangdong,  
P.R.China.

Postcode: 510663

Web: <http://www.saj-electric.com>

### **Technical Support & Service**

Tel: +86 20 6660 0082

Fax: +86 20 6660 8589

E-mail: [service@saj-electric.com](mailto:service@saj-electric.com)

### **International Sales**

Tel: 86-20-66608618/66608619/66600082/66600086

Fax: 020-66608589

E-mail: [info@saj-electric.com](mailto:info@saj-electric.com)

### **Domestic Sales**

Tel: 020-66600058/66600082

Fax: 020-66608589

## **Guangzhou Sanjing Electric CO., LTD.**

ADD: SAJ Innovation Park, No.9, Lizhishan Road, Science City,  
Guangzhou High-tech Zone, Guangdong, P.R.China

Zip: 510663 Tel: +86 20 6660 0082 Fax: 020-6660 8589

Web: <http://www.saj-electric.com>