

HITACHI INVERTER

J100-E2 SERIES

SERVICE MANUAL (ADJUSTMENT AND MAINTENANCE)

Model: J100-004SFE2 to J100-022SFE2
J100-015HFE2 to J100-037HFE2

After reading this manual, keep it at hand for future reference.

Hitachi, Ltd.
Tokyo Japan

NBS470XB

TABLE OF CONTENTS

1.	PRE-OPERATION CHECK	1-1
1.1	Check of the Inverter Model Name and Manufacturing No.	
1.2	Check of Inverter and Motor Specifications	
2.	FUNCTION OF CHECK TERMINALS	2-1
3.	TROUBLE SHOOTING PROCEDURE	3-1
3.1	Failure Messages and Diagnoses	
3.2	Description of the Codes A, B and C under the Tabulated Column Heading "Method to reset".	
3.3	Troubleshooting Procedure Based on Diagnoses by the Remote Operator	
4.	MEASUREMENT AND ADJUSTMENT OF CONTROL CHARACTERISTICS	4-1
4.1	Controlled Power Supply Voltage	
4.2	Overvoltage Detection Characteristics [Without motor]	
4.3	Overcurrent (Overload) Detection Characteristics	
4.4	Undervoltage Detection Characteristics	
4.5	Forced Resetting Characteristics	
4.6	External Frequency Indicator (Analog Meter) Adjustment Characteristics (Monitor Mode M-ADJ)	
4.7	How to Return to the Initial Setting (Setting when shipped from the factory)	
5.	OPERATIONAL ADJUSTMENT	5-1
5.1	Motor Without Load, Forward and Reverse Run	
5.2	Motor Operation with Load (100% Load)	
6.	ACTIONS TO TAKE IN AN OCCURRENCE OF ABNORMALITIES	6-1
6.1	How to Check the Converter Module	
6.2	How to Check the PM Module and Transistors Used with BRD	
6.3	How to Check the Printed-Circuit Board	
6.4	How to Check the Digital operator	
6.5	How to Check Control Signals	
7.	MAINTENANCE AND INSPECTION PROCEDURE.....	7-1
7.1	Maintenance and Inspection Precautions	
7.2	Measurement of Input/Output voltage, Current and Power	
7.3	Method to Measure Insulation Resistance and Test Withstand Voltage	
7.4	Maintenance of parts	
8.	APPENDIX	
Appendix 1	J100 Series Logic and Main Circuit Elementary Wiring Diagram	8-1
Appendix 2	J100 Series Structural Drawing	8-1

1. PRE-OPERATION CHECK

Before starting adjustment and maintenance, be sure to check the following specifications of the inverter and motor.

1.1 Check of the inverter model name and manufacturing No.

Inverter model

J100

MFG. NO.

This information is written on the name plate on the side cover of the inverter

Example of contents of specification label

- The example is for the J100 022SF E2 inverter model

HITACHI		INVERTER		022SFE2	
		J100			
INPUT			OUTPUT		
VOLTS	220-240V	220-240V	VOLTS MAX.	220-240V	
FREQ.	50Hz	60Hz	CAPACITY MAX.	2.2KW	
PHASE	1	1	AMP'S	10.5A	
DATE	1994	MFG. NO.	J100E-022S2 492A		
Hitachi, Ltd. Tokyo, Japan				NE15228	

Description of Inverter Model

J100-022 S F E 2

Series name

Version number

European type

Structure type (F: with digital operator)

Input voltage

S: Single phase 200 V class

H: Three phase 400 V class

Applicable motor capacity

004 : 0.4 KW
007 : 0.75 KW
015 : 1.5 KW
022 : 2.2 KW
037 : 3.7 KW

Description of Mfg. Number

J100-022S 26A

Main body revision No.

Production month

(1 to 9, 0; October, J; November, K; December)

Production year

(The unit digit of the year of grace)

Input voltage

S: Single phase 200 V class

H: Three phase 400 V class

Applicable motor capacity

1.2 Check of inverter and motor specifications

(1) Inverter specifications

Monitor Mode

NO.	Monitor name	Display content	Set value
1	Frequency setting and output frequency	FS000.0 000.0Hz	
		1S005.0 000.0Hz	
	Multistage speed setting and output frequency	2S020.0 000.0Hz	
		3S040.0 000.0Hz	
		4S000.0 000.0Hz	
	Expansion multistage speed	5S000.0 000.0Hz	
		6S000.0 000.0Hz	
		7S000.0 000.0Hz	
2	Acceleration time setting	ACCEL-1 0010.0S	
3	Deceleration time setting	DECEL-1 0010.0S	
4	2-stage acceleration time setting	ACCEL-2 0010.0S	
5	2-stage deceleration time setting	DECEL-2 0010.0S	
6	Frequency setting command	F-SET-M Terminal	
7	Operation command method	F/R-SW Terminal	
8	Revolution speed display	RPM 4P 00000RPM	———
9	Output current display	If - - - A Im000.0%	———
10	DC current display	PN-V 000V	———
11	Output voltage gain adjustment	V-Boost Code <31>	
12	Output voltage gain adjustment	V-Gain 100%	
13	Analog meter adjustment	M-ADJ 50	
14	Failure display	#	———
		?ERROR Over V.	In case of over voltage tripping
15	Failure history	?ERR COUNT 000	———

Function Mode

Display sequence	Function name	Standard setting	Set value
F-00	V/F pattern setting	V/F-VC 050-050	
F-01	Maximum frequency adjustment	0	
F-02	Start frequency adjustment	0.5	
F-03	Maximum frequency limiter setting	0	
F-04	Minimum frequency limiter setting	0	
F-05	Multistage-speed first speed setting	0 (Hz)	
F-06	Multistage-speed second speed setting	0 (Hz)	
F-07	Multistage-speed third speed setting	0 (Hz)	
F-08	Multistage-speed fourth speed setting	0 (Hz)	
F-09	Multistage-speed fifth speed setting	0 (Hz)	
F-10	Multistage-speed sixth speed setting	0 (Hz)	
F-11	Multistage-speed seventh speed setting	0 (Hz)	
F-12	DC braking frequency adjustment	0.5 (Hz)	
F-13	DC braking force adjustment	0	
F-14	DC braking time adjustment	0 (S)	
F-15	Electronic thermal level adjustment	100 (%)	
F-16	Acceleration selection(Linear, Curve)	Linear	
F-17	Deceleration selection(Linear, Curve)	Linear	
F-18	External frequency setting start	0 (Hz)	
F-19	External frequency setting end	0 (Hz)	
F-20	Switch selection 1	Set DC braking	DCB OFF
		Switch over of frequency monitor	FM ANA
		Switch over of the maximum frequency	fmax 120
		Switch over of trip and retry	PWER ALM
		Switch over of the motor direction when using the digital operator	DIOP FWD
		Direction of the motor (Forward)	FWD ON
		Direction of the motor (Reverse)	REV ON
F-21	Switch selection 2	Overload limiter	OLMT ON
		DC braking edge/level selection	DB LVL
		[Stop]key is effective when external run is selected	STOP ON
		Selection of electronic thermal characteristic	Ethm 100
		Selection of electronic thermal operation	Ethm ON
		Selection of software lock	SLOK ON
		Setting voltage for analog input	AIN 5V
F-22	Switch selection 3	Setting input method of analog input	AIN VOL
		Selection of analog input	AIN TER
		Change of data	SOFTFREE
		Selection of frequency arrival	FARV 2
		Selection of neglect of trip	TRIP OFF
		Debug mode display	DEBG OFF
		Software lock	TLOK ON
F-23	Switch selection 4	Selection of area	AREA EC
		Whole data setting	FUNC STD
		Trip history clear	TCNT CNT
		Terminal setting 1	TER1 CF1
		Terminal setting 2	TER2 CF2
		Terminal setting 3	TER3 2CH
F-24	Switch selection 5	Terminal setting 4	TER4 RS
		Terminal setting 5	TER5 FM
		Terminal setting 6	TER6 AR
		External trip input selection	EXT A
		RUN signal output selection	RUN I
F-25	Overload limiter constant	AVR value selection for deceleration	AVR ON
		LAD stop function selection	LAD ON
		Selection of alarm output contact A or B	ALM B
		Allowable undervoltage time	001.0S
		Stand by time after undervoltage setting	0010.0S
		DC braking usage ratio setting	5.0%
		Frequency arrival setting	ACC, DEC 100%
		Carrier frequency setting	16 kHz
		Input voltage setting	220V
		AVR voltage setting for deceleration	220V
F-33	Default data and parameter setting	10	

(2) Motor specifications

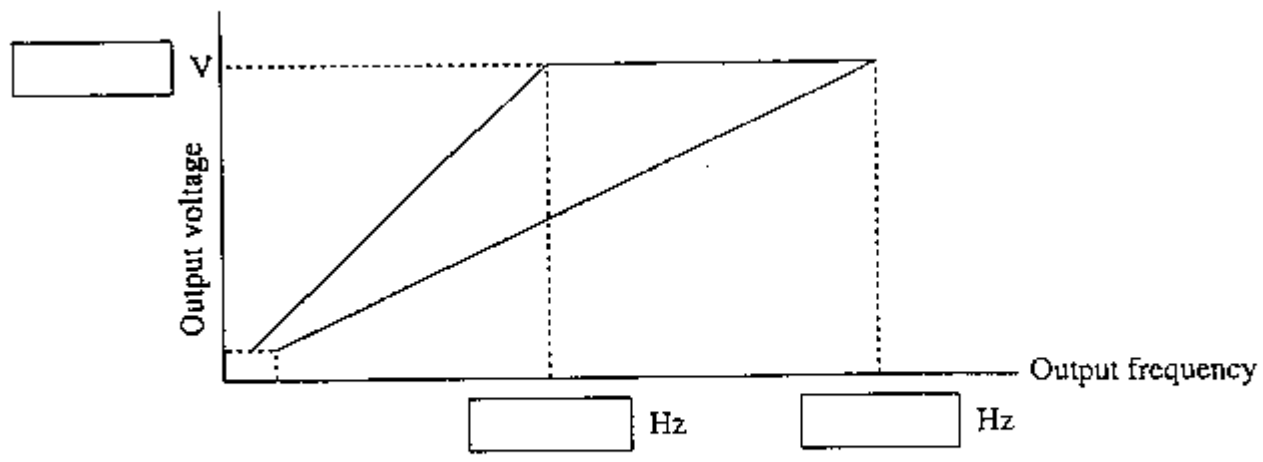

Motor mfg. number

Motor output kW

Rated current A

Number of motor poles P

Rated voltage V

Motor rated rpm r.p.m

Rated frequency Hz

Starting frequency A

(3) Mating equipment specifications

Equipment name

Required acceleration/deceleration time

Torque characteristics

Acceleration time Sec

Required torque kg-m

Deceleration time Sec

Load GD² kg-m²

Variable speed range Hz Hz

2. FUNCTION OF CHECK TERMINALS (CN1 CONNECTOR)

Table 2.1 below shows the functions of the CN1 connector on the printed-circuit board. Refer to Sub-section 4.1 for the connector location and pin numbers.

Table 2.1 Functions of check terminals

CN1 Connector Terminal symbol	Pin No.	Function	Waveform observation
PV5	CN1 (12)	Digital circuit power supply PV5 ← GNDA: 4.9 to 5.2V	DC power supply
NV12	CN1 (2)	CT/Remote operator power supply NV12 ← GNDA: -10.8 to -15.0V	DC power supply Note: When the remote operator is connected
VDC	CN1 (1)	Main circuit DC voltage detection signal: When VPN is 300VDC (200V class), 600VDC (400V class) VDC ← GNDA: 24.3 to 25.9V	DC power supply Note: When the remote operator is connected
GNDA	CN1 (13) (14)	Reference voltage for the power supply above	
U V W X Y Z	CN1 (20) (19) (8) (18) (17) (7)	PWM waveform logic signal; Period during which the main circuit transistor is ON and OFF is shown. Measurement of nonlapped logic is possible by observing waveforms by the pairs, i.e., U and X phase, V and Y phase, and W and Z phase. Allowable nonlapped period range: $t = 2$ to 4μ sec.	
IU IW	CN1 (5) (4)	Motor current detection signal: 2.8V peak (approx.) with the inverter at rated load	

CN1 Connector Terminal symbol	Pin No.	Function	Waveform observation							
TRIP	CN1 (6)	IPM module protect detection signal (approx. 5 V) TRIP ← GNDA 5 V (approx.) When IPM is tripped, "H" → "L"	DC voltage							
PV24	CN1 (22)	Power supply to Fan and Power relay <table border="1" data-bbox="486 376 890 582"> <thead> <tr> <th colspan="2">PV ← GNDB</th> </tr> </thead> <tbody> <tr> <td>004 to 007SF</td> <td>21.6 to 30.0V</td> </tr> <tr> <td>015 to 022SF</td> <td rowspan="2">21.6 to 26.4V</td> </tr> <tr> <td>015 to 037HF</td> </tr> </tbody> </table>	PV ← GNDB		004 to 007SF	21.6 to 30.0V	015 to 022SF	21.6 to 26.4V	015 to 037HF	DC voltage
PV ← GNDB										
004 to 007SF	21.6 to 30.0V									
015 to 022SF	21.6 to 26.4V									
015 to 037HF										
GNDB	CN1 (11)	Reference voltage for PV24 power supply								

3. TROUBLE SHOOTING PROCEDURE

3.1 Failure messages and diagnoses

When the inverter is out of order, be sure to take the actions indicated on Table 3.1. Find and correct the cause of the trouble and then reuse.

NOTE 1: When change of setting is required, be sure to obtain approval of the customer before changing.

NOTE 2: When checking the inverter or making repairs because of the faulty condition, be sure to follow the instructions given in Section 4 through Section 7.

Table 3.1 Failure messages and diagnoses

Phenomenon			Probable cause [Contents of message]	Method to reset	Check for:	Correction
Breaker MCB	Electromagnetic contactor Mg	Digital operator LED display [Remote operator LCD display]				
		E 1 (PM. Drive)	Overcurrent during motor constant rpm operation (Overcurrent during operation)	A	Rapid changes in load Short-circuits or grounds of output	Eliminate rapid changes in load Check output wiring and motor for shorts
		E 2 (PM. Decel)	Overcurrent during motor deceleration	A	Rapid deceleration Short-circuits or grounds of output	Increase deceleration time Check output wiring and motor for shorts
		E 3 (PM. Accel)	Overcurrent during motor acceleration	A	Rapid acceleration Short-circuits or grounds of output Too high starting frequency Too high torque boost Locked motor	Increase deceleration time Check output wiring and motor for shorts Decrease starting frequency Decrease torque boost Check motor or load
		E 4 (PM. ERR)	Excessive temperature of main element (PM) while motor is at rest. Faulty internal power supply of the inverter	A	Installed position (vertical) and wall surface (nonflammable material, such as steel plate) Cooling fan operation and ambient temperature Internal power supply	Check installation Replace cooling fan Repairs

Breaker MCB	Electromagnetic contactor Mg	Thermal relay THRY	Digital operator LED display [Remote operator LCD display]	Fault alarm relay	Probable cause [Contents of message]	Method to reset	Check for:	Correction
			E5 (Over. L)	○	Inverter over-loaded (Operation under overload)	A	Excessive load Electronic thermal level. (If not changed)	Decrease load factor Rematch to proper level
			E6 (OL. BRD)	○	Regenerative brake application time exceeding the BRD%ED value setting	A	Damping resistance usage rate, BRD%ED	<ul style="list-style-type: none"> • Increase deceleration time • Increase operating duty cycle • Raise BRD%ED setting
			E7 (Over. V)	○	DC smoothing circuit overvoltage	A	Rapid deceleration Motor forced to rotate by the load Grounding fault	Increase deceleration time Impossible to apply to continuous regenerative load Check output wiring and motor for grounds
			E8 (EEPROM)	○	E ² PROM Error	A	Large noise sources in proximity Ambient temperature (too high)	Keep noise sources away Replace cooling fan
			E9 (Under. V)	○	Faulty power supply (undervoltage)	A	Decrease in voltage Faulty contact of MCB or Mg Repeated occurrence of momentary power failure of 100msec or less by 10 times or more in 10 minutes.	Evaluate power supply system Replace MCB or Mg Evaluate power supply system
			E10 (CT)	○	CT Error	A	Faulty CT	Repairs

Phenomenon		Digital operator LED display [Remote operator LCD display]	Fault alarm relay	Probable cause [Contents of message]	Method to reset	Check for	Correction
Breaker MCB Electromagnetic contactor Mg	Thermal relay THRY						
		E11 (CPU)	○	(CPU Error)	A	Large noise sources in proximity	Keep noise sources away
		E12 (EXTERNAL)	○	External trip	A	Faulty inverter	Repairs
		E13 (USP)	○	USP Error	A	Faulty external device or equipment (When external trip function is selected)	Eliminate external device and equipmen faulty conditions
		E14 (GND. Flt)	○	Grounds at inverter output (When power is turned on)	A	If power is not turned on with inverter in RUN state (When USP function is selected)	Turn on power with inverter at rest
	○	—	—	—	C	Grounding of wiring between inverter and motor, and motor itself (Check with the megohm-meter)	Correct grounded portion
		—	—	—	C	Overload	Decrease load factor
		—	—	—	C	Improper thermal relay set value	Reset to proper value
○		—	—	—	B	Ground fault and shorts of power supply	Correct shorted or grounded portion
		—	—	—	B	Undercapacity of MCB	Increase MCB capacity
		—	—	—	B	Damaged inverter module or converter module	Repairs
○		—	—	Power failure	B	Power failure	Correct power supply
		—	—	Power failure	B	Faulty contact of MCB or Mg	Replace MCB or Mg

3.2 Description of the codes A, B and C under the tabulated column heading " Method to reset".

- A: After the motor has stopped, close between the terminals RS and L on the printed-circuit board, or press the stop/reset key of the main body digital operator.
- B: Operate the breaker and electromagnetic contactor.
- C: Reset the thermal relay after the motor has stopped.

(1) Complaint: Motor does not rotate

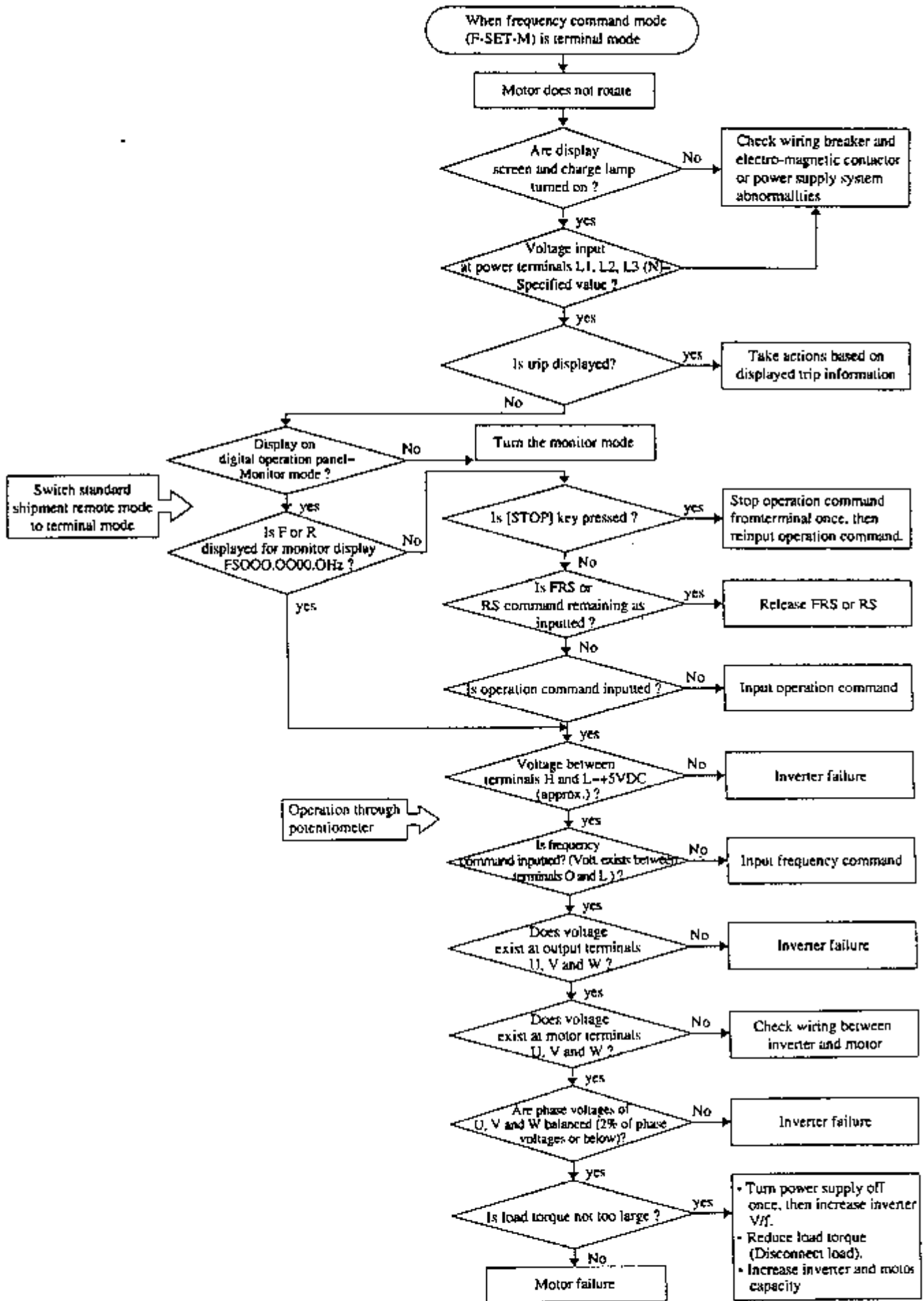

(2) Complaint: Motor does not accelerate

Select one item of the monitor mode. (Press the **FUN** key once, then press the **MON** key)

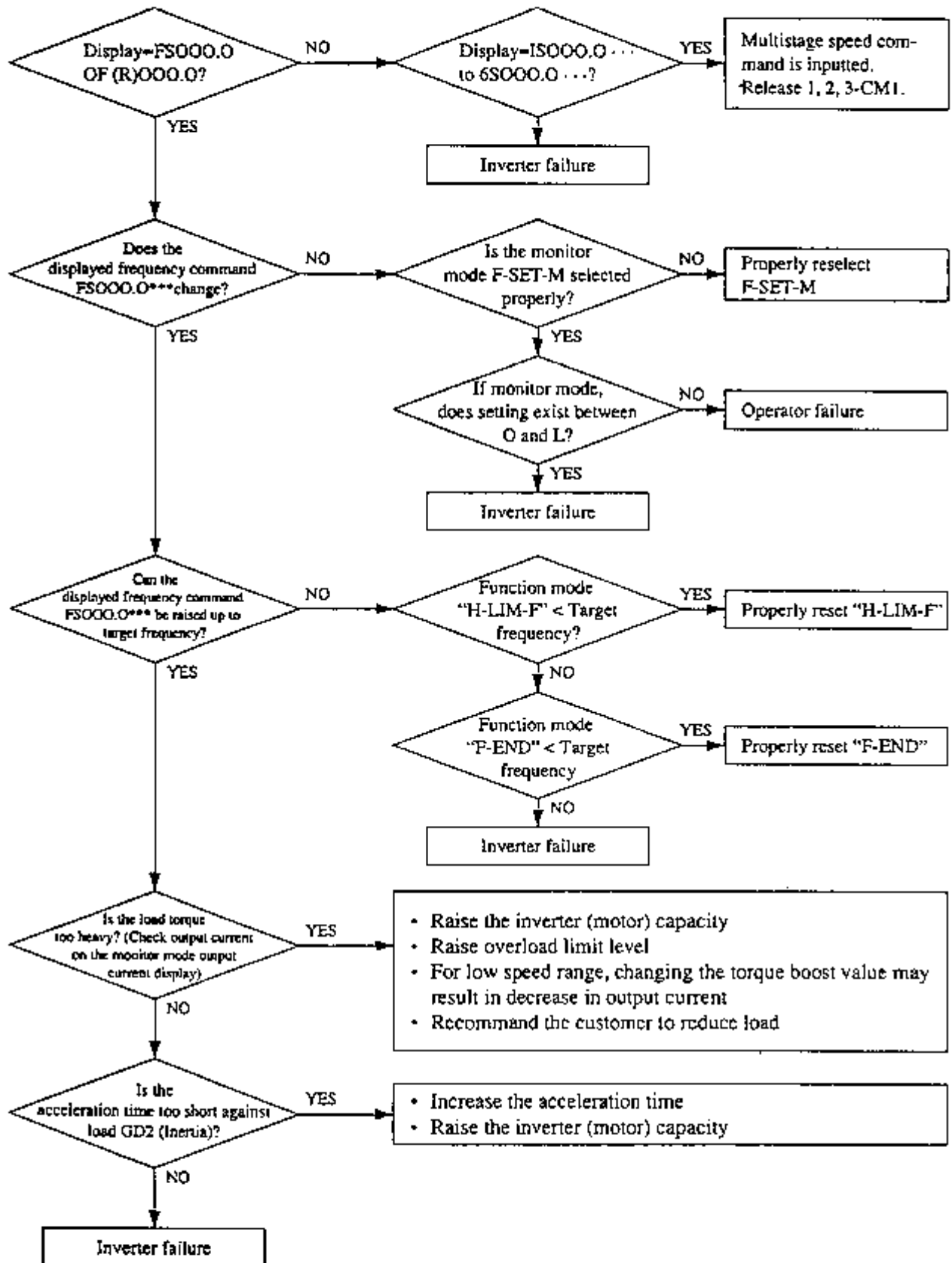

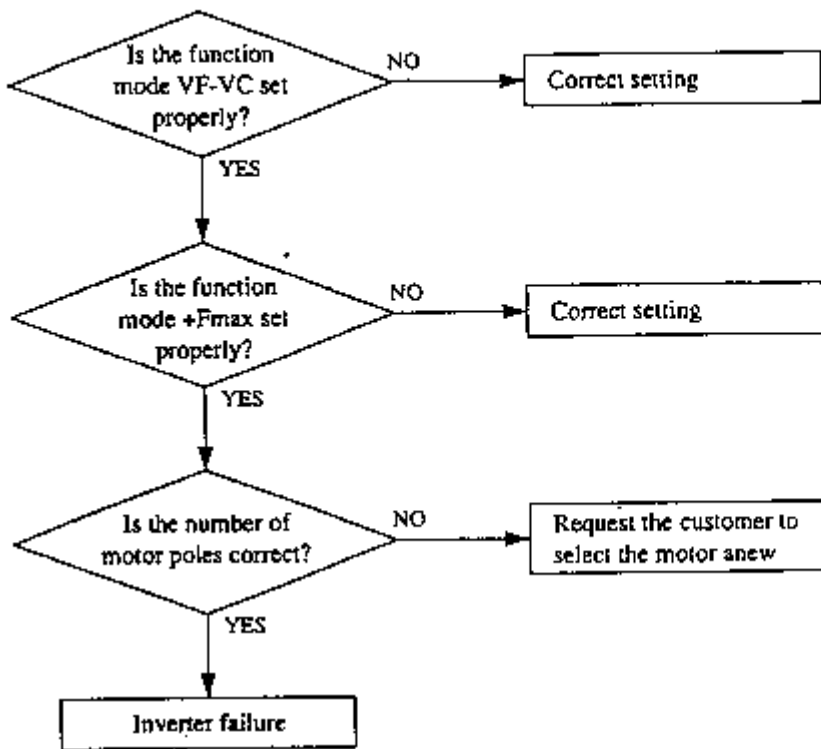

Check item	Correction
Is the STOP key on the digital operation panel not pressed while in the terminal mode?	Stop the operation command from the terminal mode once, then reinput the operation command
Is the DB command not inputted?	After turning the DB command off, input the operation command
Is the RS/FRS command not inputted?	After turning the RS/FRS command off, input the operation command
Is the frequency setting not 0?	Correct the frequency setting to a desired frequency
Is the display on the digital operation panel not the function mode?	Go to the monitor mode by pressing the MON key
Does trip happen?	Reset
If the frequency setting command mode (F-SET-M) is "Terminal", does the speed command exist between terminals O and L, or OI and L on printed board?	Evaluate the speed command circuit
There is input on the printed board at multistage speed input terminals 1 and 2; but is the setting of "SPEED1" to "SPEED3" not made OHZ?	Set "SPEED 1 to 3" to a desired frequency or cutoff the command to terminals 1 and 2
Is the command input not made externally by selecting the internal command (remote) mode or is the command input not made from the digital operation panel by selecting the external command (terminal) mode?	Check the operation mode. (Input the operation command with the mode currently set)
Are the external command (terminal) mode and the FW and RV terminals on the printed board not inputted simultaneously?	Be sure to allow either forward or reverse operation to function
Minimum frequency > Frequency set value?	Set the frequency to minimum frequency or above

(a) Overcurrent trip (PM. Accel) is actuated

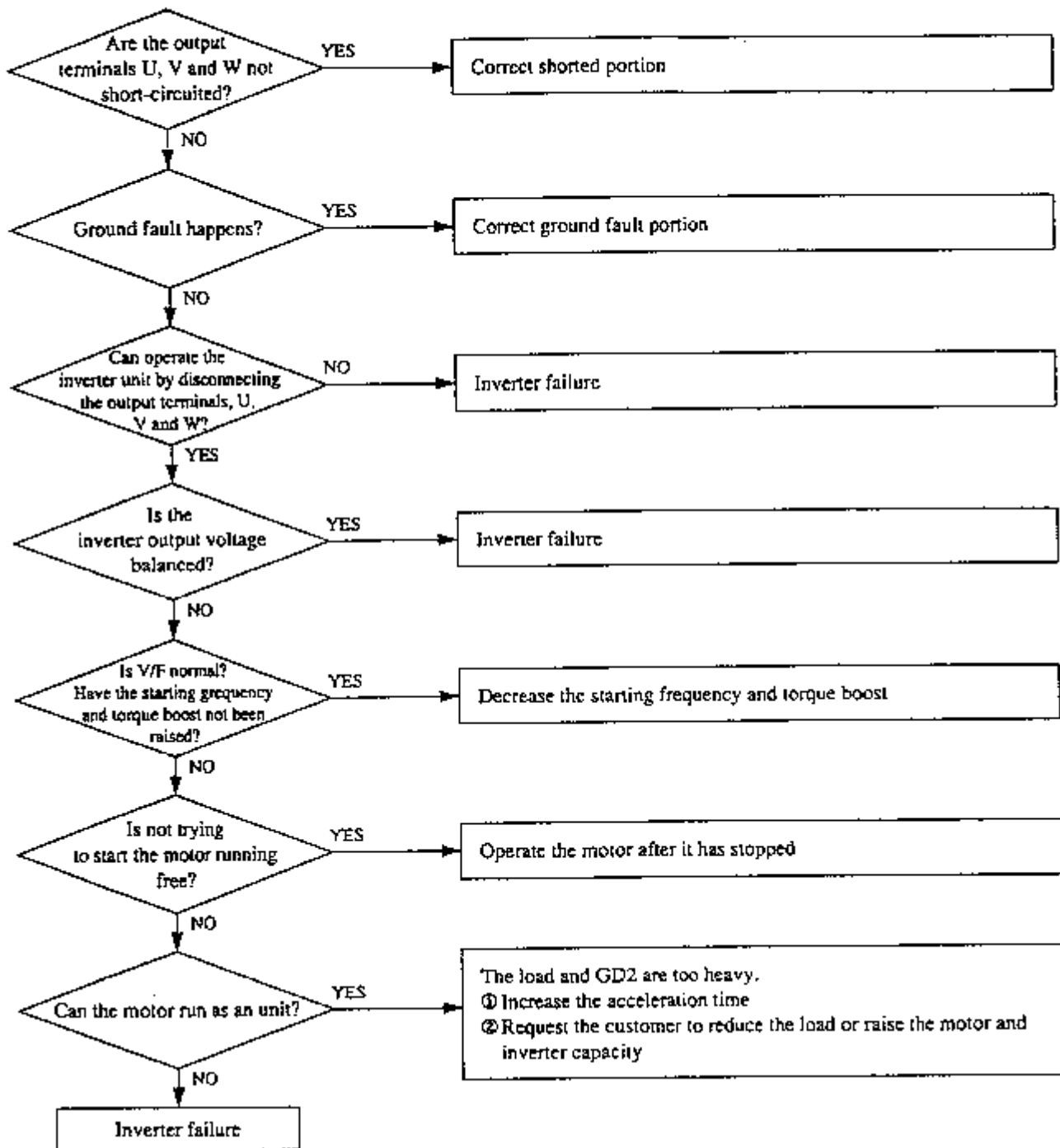

(b) Overcurrent trip (PM. Decel) is actuated

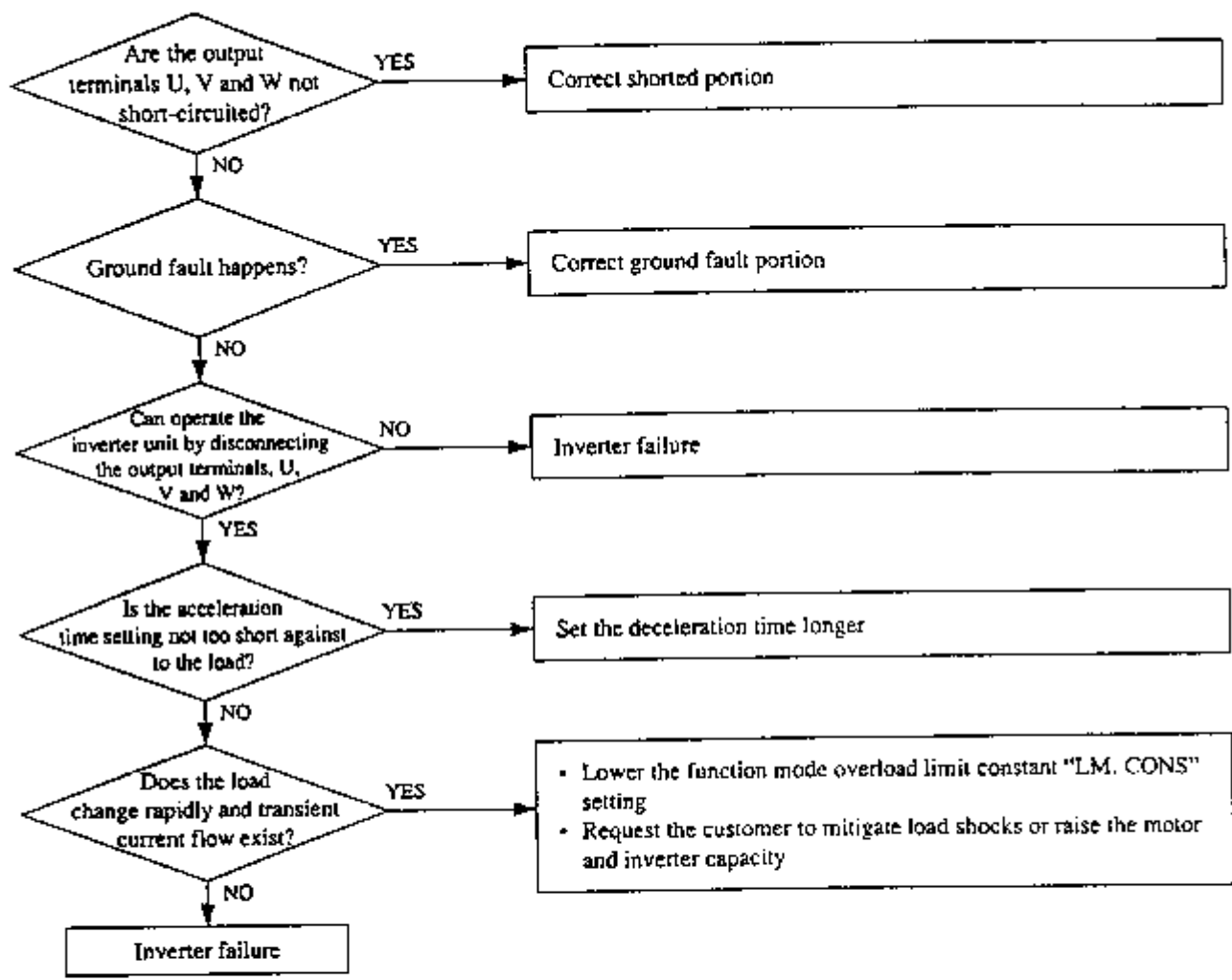

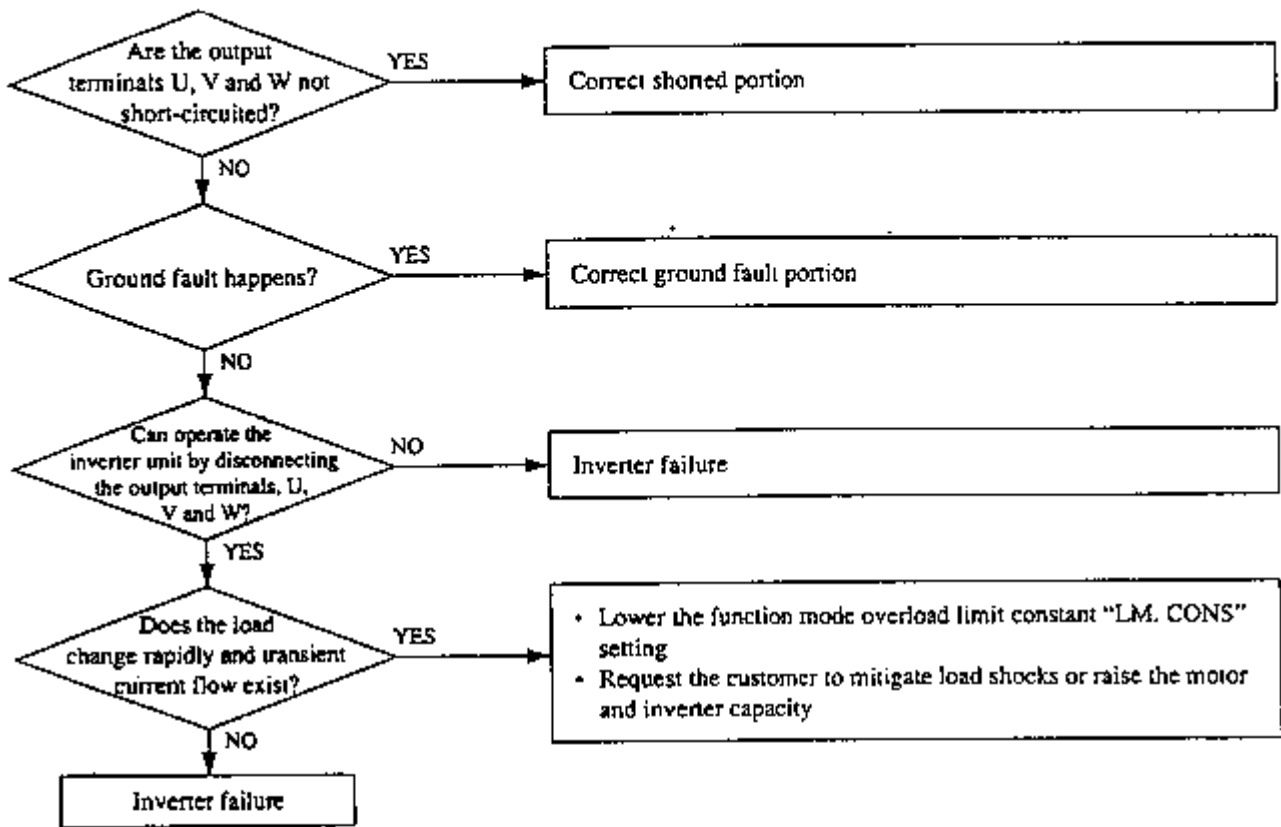

(d) Overload (OverL) is actuated

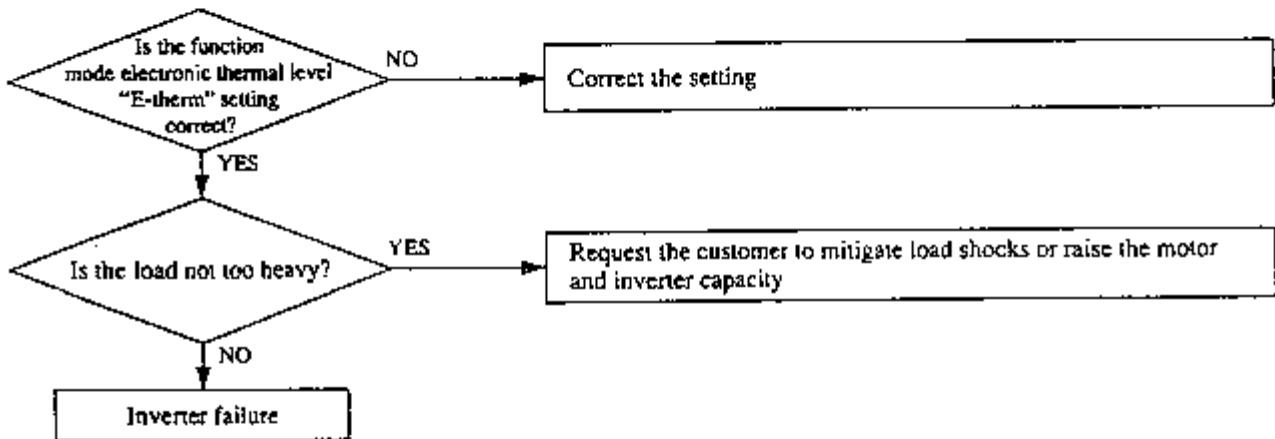

(e) Overvoltage trip (OverV) is actuated

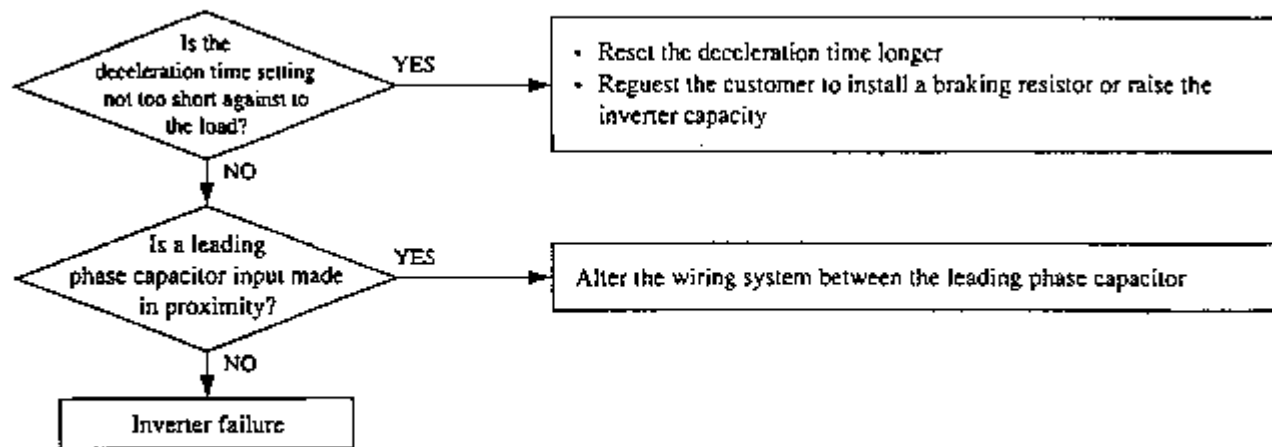

(f) Undervoltage trip (UnderV) is actuated

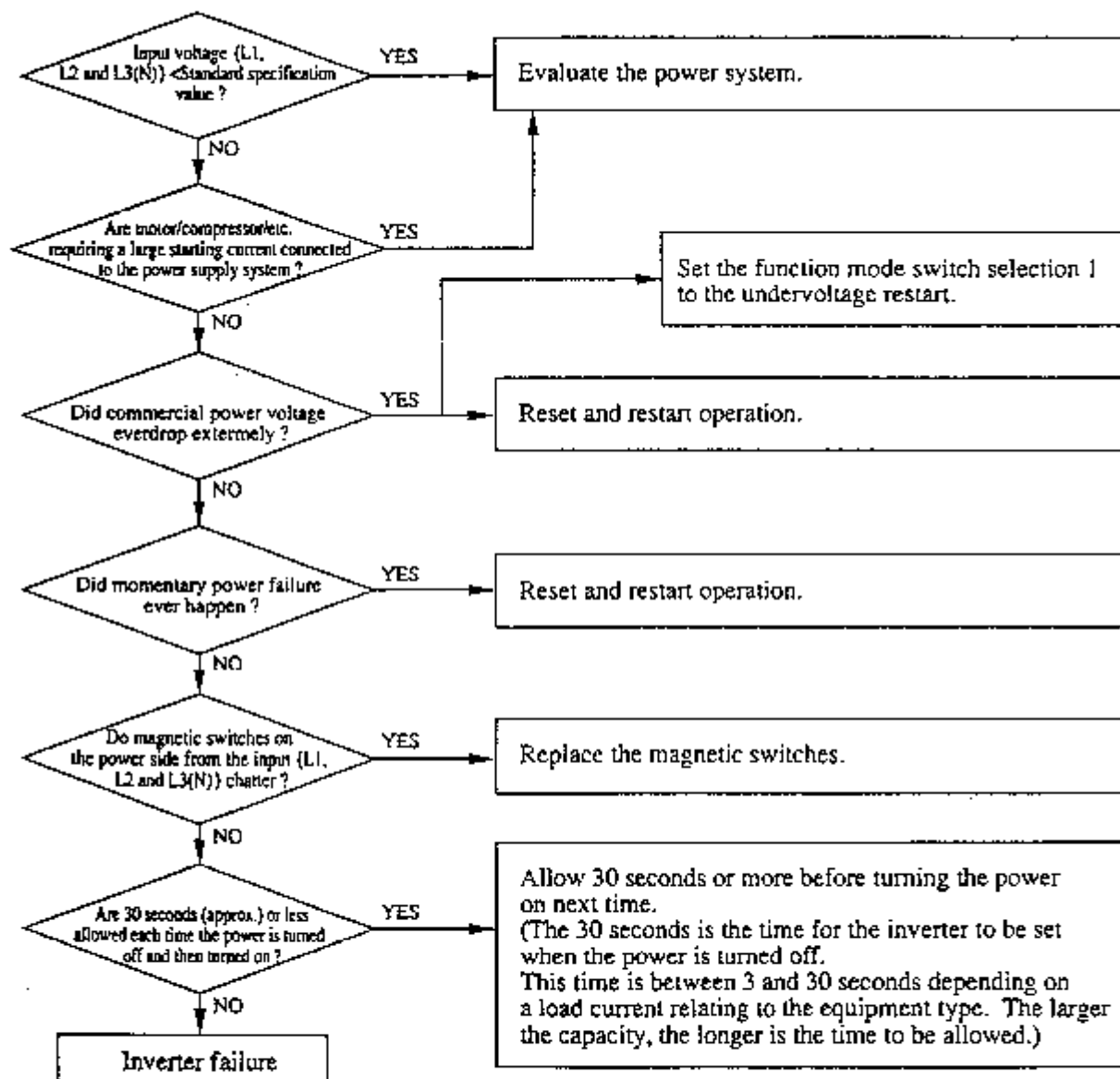

(a) Phase failure

This inverter is not provided with the phase failure protection on the power supply; hence the following are expected to happen in the event of occurrence of the phase failure.

- The normal operation will continue when there is little load, whereas the main capacitor (CB) life shortens because of an increase in the CB ripple current.
- If a load is applied, the undervoltage and overcurrent protection is actuated.

(b) Be careful of the following conditions because the converter module may be damaged.

- When the power supply voltage unbalance ratio is 3% or above.
- When the power supply capacity is ten times that of the inverter, and it is 500 kVA or greater.
- When a severe voltage transients occur

Examples: When multiple inverters are connected to a short bus.

When a leading phase capacitor is turned on/off.

In the cases above, it is recommended that a reactor of about 3 percent of the power supply voltage (voltage drop at the rated current) be inserted on the power supply.

4. MEASUREMENT AND ADJUSTMENT OF CONTROL CHARACTERISTICS

4.1 Controlled Power Supply Voltage

Description	Allowable voltage range (V)	Measurement location	
		+	-
PV5 (for +5 V use) power supply	4.9 to 5.2	CN1 (12)	CN1 (13)
NV12 (for -12 V use) power supply ^(NOTE)	-10.8 to -15.0	CN1 (2)	CN1 (13)
PV24 (for +24 V) power supply	004 to 015SF	CN1 (22)	CN1 (11)
	21.6 to 30.0		
	022SF, 015 to 037HF		
VDC voltage (for detection of DC bus voltage)	200 V class 24.3 to 25.9 V at 300 VDC	CN1 (1)	CN1 (13)
	400 V class 24.3 to 25.9 V at 600 VDC		

NOTE: With the remote operator connected

* CN1s shown above are for the right hand side connector of the main body.
(See the picture at the bottom).

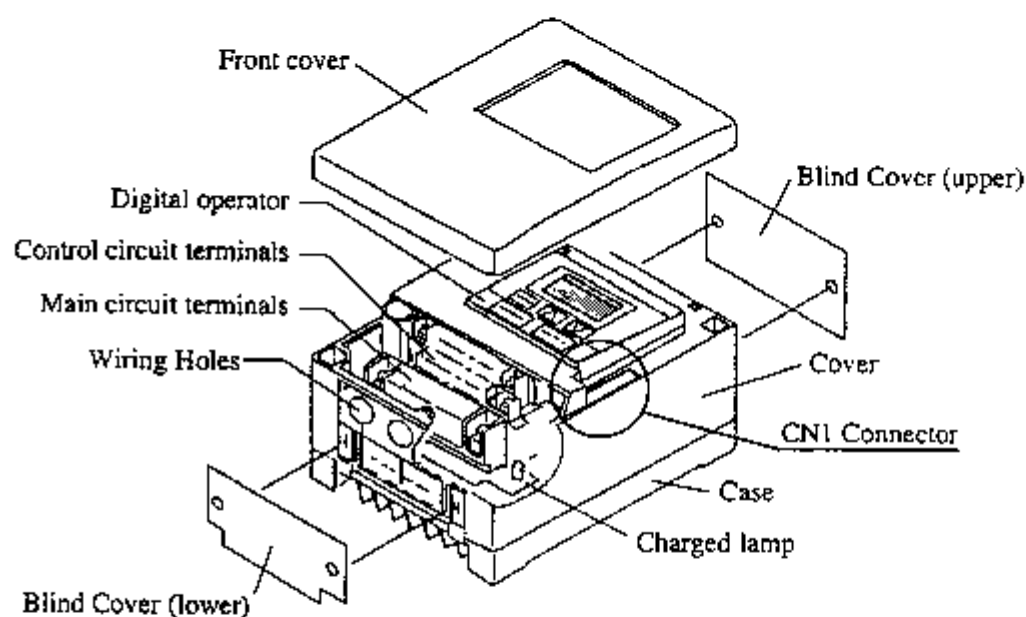

Appearance of J100 (example: 004SF)

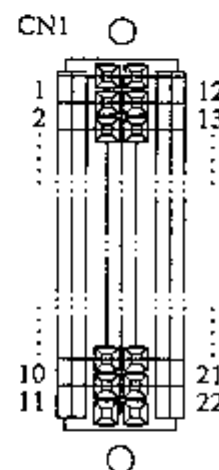

CN1 connector

Make detections of the following by varying the main circuit voltage {L1,L2 and L3(N)} which have been adjusted with the variable transformer. When checking the BRD function, connect a resistance of hundreds kΩ between P and RB.

Description		Model	Detected voltage (between P and N on main circuit)	Criteria
BRD	ON	004 to 022SF	330 to 350 VDC or above	Connect an oscilloscope from RB to P (+). The voltage waveform must become "L".
		015 to 037HF	660 to 700 VDC or above	
	OFF	004 to 022SF	330 to 350 VDC or below (When V-SET is set to 200V)	Connect an oscilloscope from RB to P (+). The voltage waveform must become "H".
		015 to 037HF	660 to 700 VDC or below (When V-SET is set to 400V)	
OV-TRIP	004 to 022SF	375 to 405 VDC	<ul style="list-style-type: none"> • The output power turned off: Logic PCB: Control circuit: check round PU ← control circuit terminal L must be "H" LEVEL • Alarm relay output: ALO-AL1 ON → OFF when B contact is selected. • Overvoltage trip display: "?ERROR Over. V" (Remote operator display) 	
	015 to 037HF	750 to 810 VDC		

NOTE 1: Use care when checking BRD function, because measurement of high voltage is involved.

NOTE 2: Since there is no N(-) terminals on the main circuit, use P terminal and (-) pin on the diode module (DM).

4.3 Overcurrent (Overload) Detection Characteristics

With the motor running, gradually increase the load and then make the following measurement.

Description	Method to test	Criteria	Remarks
Overload limit level	① F-24 LM.CON S 50% 01.0 setting: Apply a load of 40 to 60 percent of the inverter rated current. ② F-24 LM.CON S 150% 01.0 setting: Apply a load of 140 to 160 percent of the inverter rated current.	Output frequency must start decreasing.	Possible to change LM.CON setting with the remote operator connected
Overload trip	Apply a load of 180 percent of the inverter rated current.	<ul style="list-style-type: none"> • Overload trip must occur in about 10 to 20 seconds • The output power turned off. {CN1(13) to CN1(20)}; "H" level) • Alarm output (AL0-AL1 ON → OFF).* • Overload trip display: ("ERROR Over. L" (Remote operator display)) 	Impossible to limit overloading with LM.CON S 150% 31.0 setting (Use the remote operator.)
Overcurrent trip	Apply a load of 200 to 220 percent of the inverter rated current.	<ul style="list-style-type: none"> • The output power turned off > {CN1(13) to CN1(20)}; "H" level) • Alarm output (AL0-AL1 ON → OFF).* • Overcurrent trip display: ("ERROR OC. Drive" (Remote operator display)) 	Impossible to limit overloading with LM.CON S 150% 31.0 setting (Use the remote operator.)

* When B contact is selected for alarm relay output.

4.4 Undervoltage Detection Characteristics

Operate the inverter at the maximum output frequency

As the main circuit power supply voltage {L1, L2 and L3(N)} is gradually decreased through the variable transformer, the output has to be turned off or Undervoltage trip must occur (this operation to be carried out at the rated load).

Description	Model	Operating voltage (Input voltage)	Criteria
Undervoltage	004 to 022SF	140 to 160 VAC	• The output power turned off. {CN1(13) to CN1(20)}; "H" level)
	015 to 037HF	280 to 320 VAC	• Alarm output: AL0-AL1, ON → OFF When b contact is selected. • Undervoltage display: ("?ERROR Under. V")

Following the detective operation, execute a latching. After resetting (by short-circuiting RS to L, or pressing the [STOP] key,) release the latching.

4.5 Forced Resetting Characteristics

Description	Operation	Criteria
Forced resetting	Short circuit RS to PV24 on the printed board.	The abnormal mode must be rest.

4.6 External Frequency Indicator (Analog Meter) Adjustment Characteristics (Monitor Mode M-ADJ)

Connect the remote operator. Select [F-21 SWITCH] with the function mode, and set to [SWITCH FM ANA]. In this state, an output (t/T) which is proportional to the output frequency is available between FM- on the printed-circuit board.

Adjust the M-ADJ constant on the monitor mode so the meter reading becomes maximum at the maximum frequency.

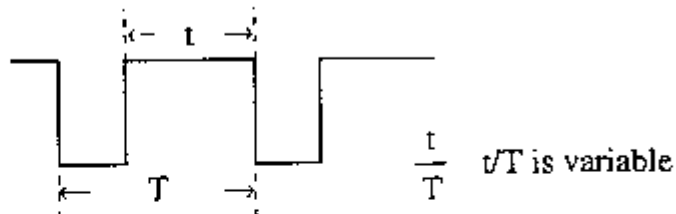
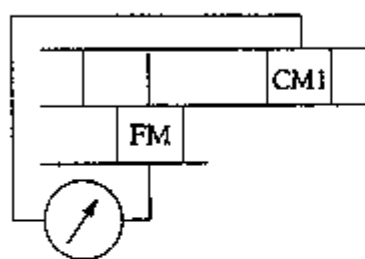

4.7 How to return to the initial setting (Setting when shipped from the factory)

Follow the following procedure when it is necessary to return to the initial setting made the factory.

- ① Short circuit FW, RV and 1 terminal to PV24 on the control circuit terminal.
- ② Turn the power on.
- ③ Make the FW, RV and 1 terminal open when **0.0.0** is displayed on the digital operator.
(The remote operator display **FS000.0HZ.000.0HZ**)
- ④ Turn the power off after six seconds or more have past.
(If the power is turned off within six seconds, the initial setting may be ineffective)

NOTE: The following table shows how to return to the initial setting for Europe, Japan and US version.

I/O Version	FW	RV	1	2	3	Setting for
Europe	Close	Close	Close			Factory setting
US	Close	Close	Close	Close		
Japan	Close	Close				
Europe	Close	Close			Close	Factory setting and error clear
US	Close	Close	Close	Close	Close	
Japan	Close	Close		Close	Close	

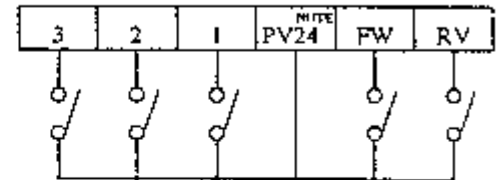

NOTE: J100-E series should be CM1, PV24 is for J100-E2 series.

5. OPERATIONAL ADJUSTMENT

5.1 Motor no-load, forward and reverse operations

The motor must accelerate without allowing the OC-TRIP to occur, when the motor is run forward first, and then with the use of the selection switch, the speed is decreased and the operation is switched over to the reverse run.

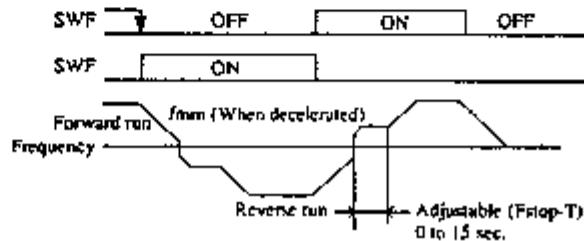
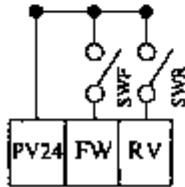

* J100-E series should be CM1.
PV24 is for J100-E2 series.

5.2 Motor operation with load (100% load)

Description	Operation	Criteria
Balance of output voltage and current	Make measurements of the voltage and current at the inverter output (U, V and W). (See Section 7)	<ul style="list-style-type: none"> Free from open phase, etc. Balanced output voltage and current Motor operation free from abnormal noises
Current monitor	Check the output current values on the operation monitor (F1).	90 to 110% of the inverter rated current (approx.)
Voltage monitor	Check the DC voltages values on the operation monitor (F1). Check the DC voltages (Vpn).	The value depends on input voltages [004 to 022 SF] 270 volts (approx.) against the 200 VAC input [015 to 037 HF] 540 volts (approx.) against the 400 VAC input

6. ACTIONS TO TAKE IN AN OCCURRENCE OF ABNORMALITIES

6.1 How to check the converter module

Possible to check the module with the tester

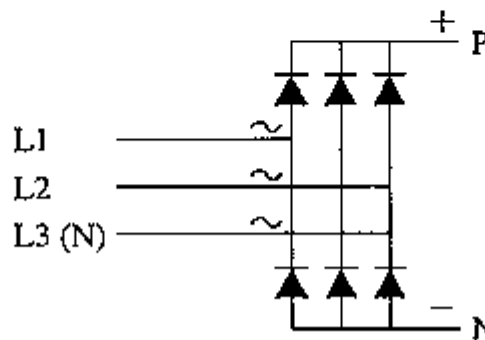

Circuit diagram of the converter module

Turn the power off and start the work after the DC bus voltage has become 15 volts or below. Use the 1 Ω range when making measurements with the tester. (A simple way to check the module as assembled)

Tester terminal	Resistance value
Three different ways for ~→~ (corresponding to L1-L2, L2-L3 (N) and L1-L3 (N))	50k Ω or above
P(+) → Each of L1, L2 and L3 (N)	50k Ω or above
Each of L1, L2 and L3 (N) → P(+)	50k Ω or below
N(-) → Each of L1, L2 and L3 (N)	50k Ω or below
Each of L1, L2 and L3 (N) → N(-)	50k Ω or above

~ : AC terminal (L1, L2 and L3 (N))

NOTE: Since there is no N(-) terminals on the main circuit terminal, use the following terminals when making the measurements.

- 004 to 007SF: N(-) pin at the diode module (DM) connection
- 015 to 022SF, 015 to 037HF: N connector at the capacitor PCB connection

Replace the converter module if any of the measurements is out of the values shown above.

- Trouble to occur when the converter module fails: MCB trip (Short-circuit of the power supply)

Check the module with the tester

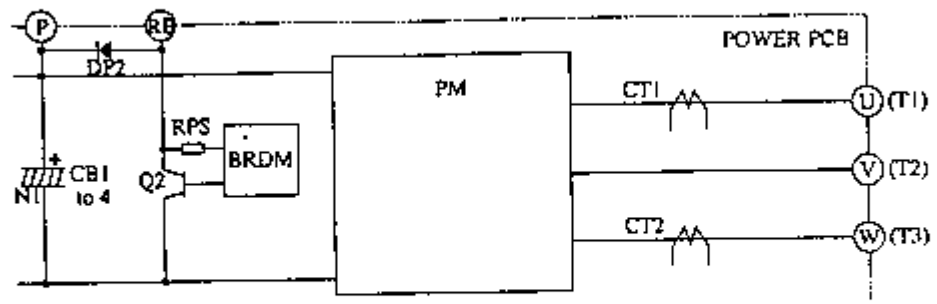

Inverter module circuit diagram (004 to 022SF)

Turn the power off and start the work after the DC bus voltage has become 15 volts or below. Use the 1Ω range when making measurements with the tester. (A simple way to check the module as assembled)

NOTE: There is a possibility that the module is out of order even when judged to be standards.

Tester terminal	Resistance value	Location to check
P → U	50kΩ or below	U phase upper arm
P → V		V phase upper arm
P → W		W phase upper arm
N(-) → U	50kΩ or above	U phase upper arm
N(-) → V		V phase upper arm
N(-) → W		W phase upper arm
U → P	50kΩ or below	U phase upper arm
V → P		V phase upper arm
W → P		W phase upper arm
U → N(-)	50kΩ or above	U phase upper arm
V → N(-)		V phase upper arm
W → N(-)		W phase upper arm
N(-) → RB	50Ω or below	BRD transistor (004
RB → N(-)	50kΩ or above	
N(-) → RB	50kΩ or above	BRD transistor with to 037HF)
RB → N(-)	50kΩ or above	

NOTE: Since there is no N(-) terminals on the main circuit terminal, use the following terminals when making the measurements.

- 004 to 007SF: (-) pin at the diode module (DM) connection
- 015 to 022SF, 015 to 037HF: N connector at the capacitor PCB connection

Troubles to occur:

When the PM module fails:

- The OC trip occurs even when the motor is not connected.



When the BRD transistors (BRD transistors within PM) fail:

- BRD discharge resistor heats up

6.3 How to check the printed-circuit board

Visually check the mounted printed-circuit board for damaged resistor and thick-film module (called BRDM (004 to 022SF)/PSM), short-circuited IC lead due to deposited foreign matter and abnormal or disconnected connector.

6.4 How to check the frequency setting digital

Select "01" for F9 with [FUNC] key and   key on the digital operation panel, and connect the frequency setter between the terminals O and L on the printed-circuit board. Set the frequency to a maximum, select F1 with the [FUNC] key on the operation panel and press the [RUN] key. (In the case of the remote operator, select "Terminal" for F-SET-M)

Be sure to check if the frequency can be set to a maximum setting value. (Example)

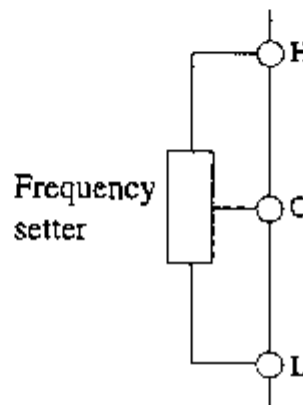

6.5 How to check control signals

While operating the inverter, PWM waveforms appear between the connector CN1(20) pin(U) or CN1(18) pin(X) and CN1(13) pin (GNDA). Note that these PWM waveforms are different depending on the frequency setting.

When the PWM waveform is incorrect, replace the control board.

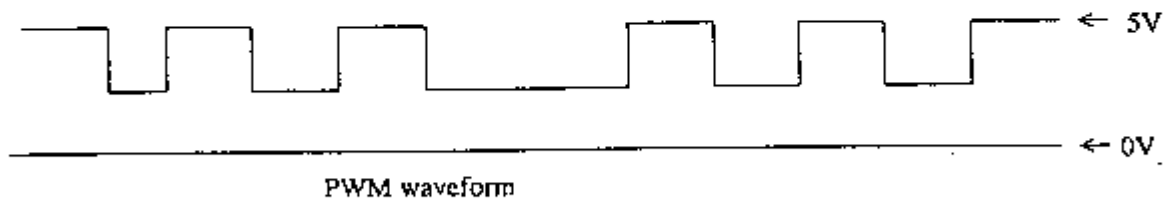

- CN1(20) pin ← CN1(13) pin (U ← GNDA) CN1(20) pin ← CN1(13) pin (X ← GNDA)
- CN1(19) pin ← CN1(13) pin (V ← GNDA) CN1(17) pin ← CN1(13) pin (Y ← GNDA)
- CN1(8) pin ← CN1(13) pin (W ← GNDA) CN1(7) pin ← CN1(13) pin (Z ← GNDA)

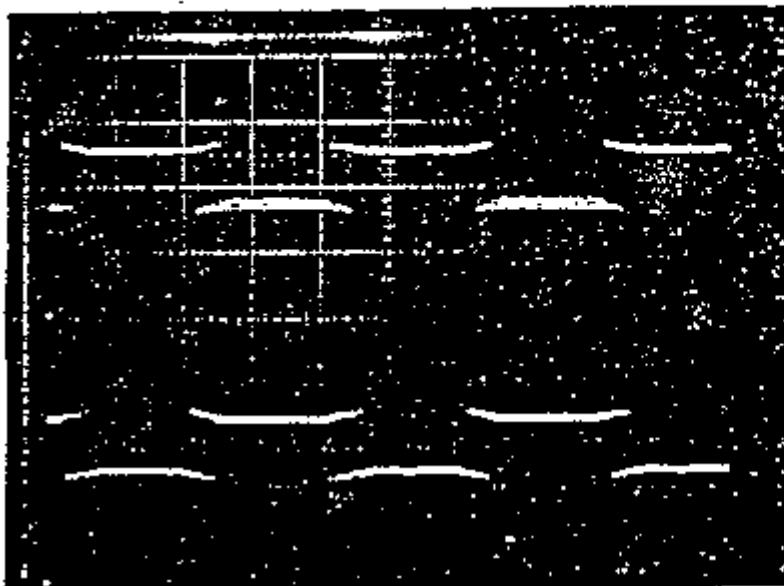

CN1(20) pin ← CN1(13) pin
(U) (GNDA)

0V

CN1(18) pin ← CN1(13) pin
(X) (GNDA)

0V

f=60Hz

2V/div
5ms/div

7. MAINTENANCE AND INSPECTION PROCEDURE

7.1 Maintenance and inspection precautions

(1) Precautions before starting maintenance and inspection

Be sure to confirm the following before starting maintenance and inspection because there is a danger of receiving an electric shock.

- The display on the digital operation panel has turned off and the charge lamp on the PCB has gone out (J100-022SF takes about 4 minutes for example).
- The DC bus voltage is 15V or below when measured with the tester.

(2) General precautions

Always keep the unit clean so that dust or other foreign matter does not enter the inverter. Use special care with respect to broken lines and faulty connections. Firmly connect terminals and connectors. Keep electronic equipment away from moisture and oil. Dust, steel filings and other foreign matter can damage insulation, causing unexpected accidents, so take special care.

7.2 Measurement of input/output voltage, current and power

General measuring instruments for input/output voltage, current and power are shown in Figure 7.3 and Table 7.1.

The voltage to be measured is the fundamental wave effective value and the power to be measure is the total effective value.

(1) Measurement of output voltage

The moving-iron type instrument does not give accurate readings for measurement of the output voltage. Make measurements according to the method shown in Figure 7.3 (Table 7.1) or using the circuits indicated in Figures 7.1 and 7.2.

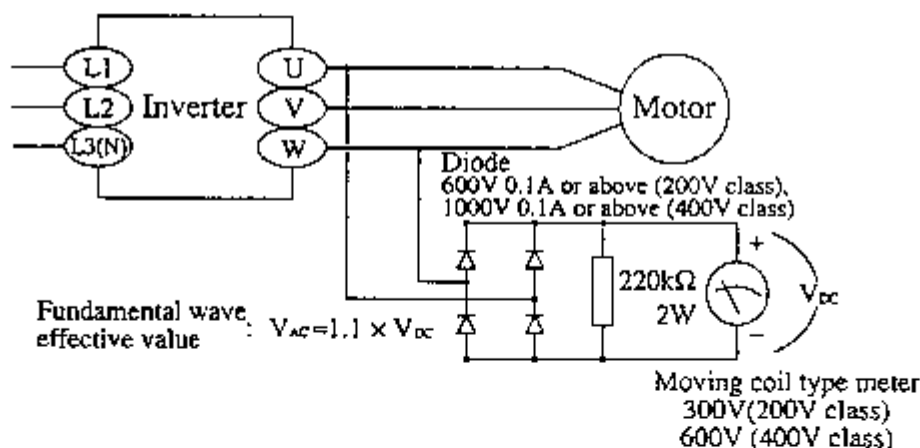

Figure 7.1 Output voltage measurement circuit

When a load is not connected to the output terminals U, V and W, voltage is present at them because of the leakage current of semiconductors (about 2mA) even when the output frequency command is made naught.

When connecting the voltmeter to the output terminals under the conditions mentioned above, make connections as indicated in Figure 7.2 to prevent the indication error of the meter.

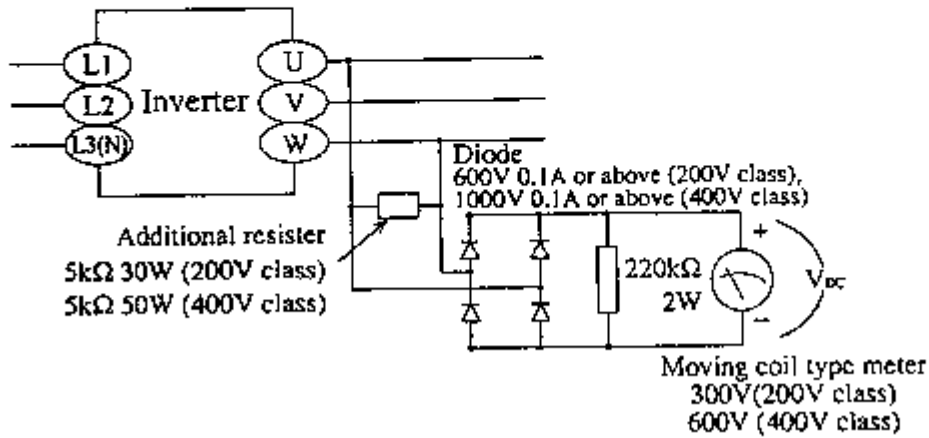

Figure 7.2 Output voltage measurement circuit

(2) Measurement of input voltage and input/output current

Make measurements of the input voltage and input/output current for all of the three phases with the moving-iron type meter (See Figure 7.3 and Table 7.1).

(3) Measurement of input/output power

Make measurements of the input/output power with the electrodynamic type wattmeter for single phase use. Make measurements for all of the three phases in cases where there is an unbalance in voltages and currents.

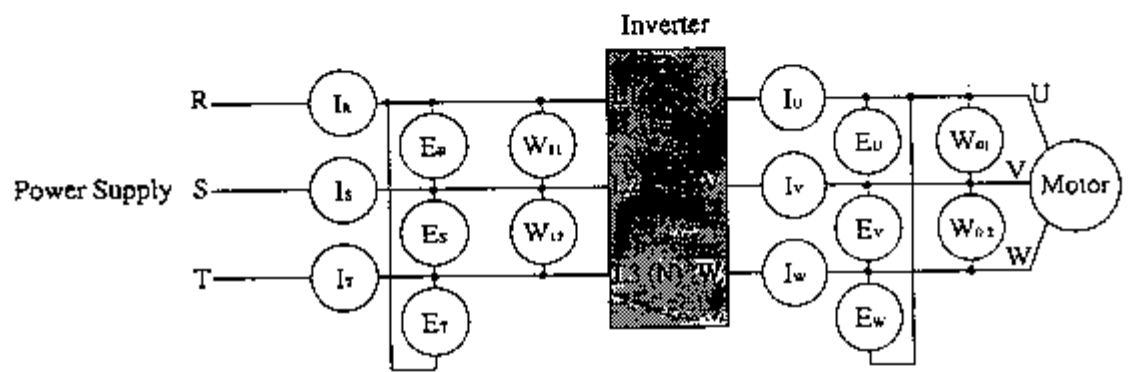







Figure 7.3 Parts to be measured

Table 7.1 Measuring instruments

Measuring item	Parts to be measured	Measuring instrument	Remarks
Supply voltage E_1	Between L1 and L2, L2 and L3(N), L3(N) and L1 (E _{R-S})(E _{ST})(E _{T-R})	 Moving-iron type voltmeter or rectifier type voltmeter	Fundamental wave effective value
Supply current I_1	Amperage at L1, L2 and L3(N) (I _R)(I _S)(I _T)	 Moving-iron type ammeter	Total effective value
Supply power W_1	Between L1 and L2, and L2 and L3(N) (W ₁₁)(W ₁₂)	 Electrodynamic type wattmeter	Total effective value
Supply power factor Pf_1	Calculate the supply power factor from the measured supply voltage, E_1 , supply current I_1 and supply power W_1 $Pf_1 = \frac{W_1}{\sqrt{3} \cdot E_1 \cdot I_1} \times 100(\%)$		
Output voltage E_0	Between U and V, V and W, W and U (E _{U-V})(E _{V-W})(E _{W-U})	 Refer to Figure 7-2 or rectifier moving-iron type ammeter	Total effective value
Output current I_0	Amperage at U, V and W (I _U)(I _V)(I _W)	 Moving-iron type ammeter	Total effective value
Output power W_0	Between U and V, V and W (W ₀₁)(W ₀₂)	 Electrodynamic type wattmeter	Total effective value
Output power factor Pf_0	Calculate the output power factor from the output voltage E_0 , output current I_0 and output power W_0 $Pf_0 = \frac{W_0}{\sqrt{3} \cdot E_0 \cdot I_0} \times 100(\%)$		

NOTE 1: Use a meter indicating a fundamental wave effective value for voltage, and meters indicating total effective values for current and power.

NOTE 2: Since the inverter output waveform is a distorted wave, the measuring instruments shown in the table above are liable to cause errors at low frequencies. The measuring method and instruments indicated above provides comparatively accurate values. Some testers (general-purpose products) are not applicable to the distorted wave.

NOTE 3: For the input and output current, measurements of the power are made with the digital power meter, e.g., YEW 2503 and 2504.

Make these measurements and tests by short-circuiting the terminals as shown in Figure 7.4, and by following the conditions described.

[Conditions]

- a) Make insulation resistance measurements between the terminals and grounding with the 500DCV megaohm-meter, and make sure that 5 M-ohms or greater is indicated.
- b) Withstand voltage test

Make withstand voltage tests by supplying 1500VAC (200V class), or 2000 VAC (400 V class) to between the terminals and grounding for one minute, and make sure that there are no abnormalities.

- Do not conduct withstand voltage tests for terminals other than those indicated in Figure 7-4.

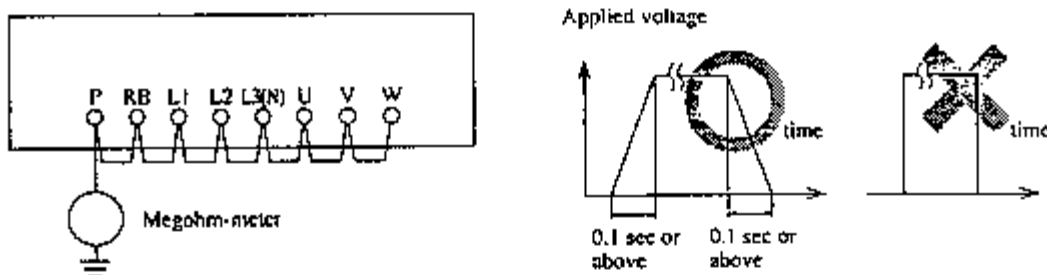

Figure 7.4 Insulation Resistance Tests and Withstand Voltage Tests

7.4 Maintenance of parts

- (1) Printed-circuit boards are maintenance-free under normal applications. However, in cases in which maintenance and inspection are necessary, pay attention to the prevention of damage caused by static electricity as shown below, and be sure to follow the instructions in Section 4. MEASUREMENT AND ADJUSTMENT OF CONTROL CHARACTERISTICS and Section 5. OPERATIONAL ADJUSTMENT.

- Prevent damage caused by static electricity

The MCUs and LSIs on a printed-circuit board can be destroyed by static electricity, so be sure to ground work benches, soldering irons, and yourself before working on a printed-circuit board.

- (2) Maintenance of smoothing capacitor and cooling fan

We recommend that smoothing capacitors CB and cooling fans be regularly replaced every three years taking their lives into account. Note that their lives shorten when they are used, in particular, under high temperatures and heavy loads.

8. APPENDIX**Appendix 1 J100 series logic and main circuit elementary wiring diagram**

Type	Logic diagram No.	Main circuit diagram No.
J100-004SFE2	2T800924	3T813644
J100-007SFE2	Ditto	Ditto
J100-015SFE2	Ditto	3T813643
J100-022SFE2	Ditto	Ditto
J100-015HFE2	Ditto	3T813642
J100-022HFE2	Ditto	Ditto
J100-037HFE2	Ditto	Ditto

Appendix 2 J100 series structural drawing

Type	Structural drawing No.
J100-004SFE2	3T810495
J100-007SFE2	3T810496
J100-015SFE2	3T810498
J100-022SFE2	Ditto
J100-015HFE2	3T810499
J100-022HFE2	Ditto
J100-037HFE2	Ditto

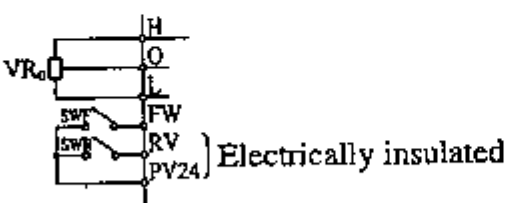
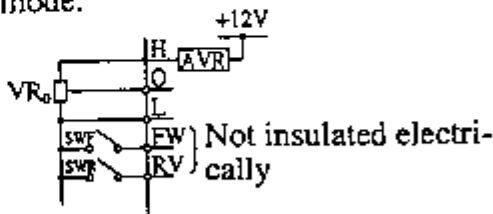
Content	J100 series		VWS-3 series	
	Terminal symbol		Terminal symbol	
Run/stop command. Forward/reverse run command	H • O • L • FW • RV • PV24	<p>*Select operation and frequency commands, with the change setting mode F9.</p>  <p>Electrically insulated</p> <p>* SWF-ON: Forward run. OFF: Stop * SWR-ON: Reverse run. OFF: Stop</p> <p>Note that STOP is effected when SWF and SWR are ON simultaneously</p>	H • O • L • FW • RV	<p>Make frequency settings with the monitor mode, and select operation/stop command with the "Terminal" mode.</p>  <p>Not insulated electrically</p> <p>* SWF-ON: Forward run. OFF: Stop * SWR-ON: Reverse run. OFF: Stop</p> <p>Note that STOP is effected when SWF and SWR are ON simultaneously</p>
Frequency command (voltage input)	O • L	<p>* At fmax with 5V or 10V between O and L (Select with remote operator switch selection 2②)</p> <p>① Voltage between H and L: 5V ② Possible to use up to 500 to 2 kΩ of VR₀</p> <p>* Output frequency gain-bias function for the analog command between O and L is possible to set with the remote operator function mode F-18 (F-START) and F-19 (F-END). The maximum frequency adjustment is possible with F-01 (Fmax).</p>	O • L	<p>* At fmax with 10V between O and L</p> <p>① Voltage between H and L: 10V (AVR used) ② Possible to use up to 500 to 2 kΩ of VR₀ with a built-in AVR</p> <p>* Output frequency gain-bias function for the analog command between O and L is possible to set with the digital operation panel function mode F-26 (F-START) and F-27 (F-END). The maximum frequency adjustment is possible with F-3 (+fmax).</p>

Content	Terminal symbol	J100 series	Terminal symbol	VWS-3 series
Frequency command (current input)	OI • L	<p>Make selections with switch selection 2 ⑦ of the remote operator.</p> <p>* Input impedance 250Ω</p> <p>Input/output characteristic Setting of the start point (F-START) and end point (F-END) of the frequency for 4 to 20mA is possible with the function mode F-18 and F-19.</p>	OI • L	<p>Make selections with switch selection 2 ⑦ of the remote operator.</p> <p>* Input impedance 250Ω</p> <p>Input/output characteristic * Input impedance 250Ω Selection of the start point (F-START) and end point (F-END) of the frequency for 4 to 20mA is possible with the function mode F-26 and F-27. The inversion of the two-dot chain line is also possible.</p>

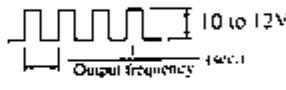
Content	Terminal symbol	J100 series	Terminal symbol	VWS-3 series
Frequency monitor	FM • CM1	<p>Possible to monitor the inverter output frequency or output current.</p> <p>The output frequency monitor provides either analog or digital signal output.</p> <p>The output current monitor provides an analog signal only. Make selections with switch selection 1 ② and 4 ⑤.</p> <p>* Analog frequency monitor signal</p> <p>① Analog meter specification: 10V, 1mA full scale.</p> <p>② A digital duty control signal proportional to the output frequency is outputted as a maximum frequency full scale.</p> <p>③ Meter reading adjustment is possible with M-ADJ of the monitor mode.</p> <p>* Digital frequency monitor signal (for the use of frequency counters)</p> <p>① The output duty of a pulse series with the same frequency as the output frequency is about 50%.</p>  <p>* Analog current monitor signal</p> <p>A digital duty control signal proportional to the output current is outputted as a 200% full scale of the inverter rated output current.</p>	FM • L	<p>Possible to use those for the use of analog meters and digital frequency counters with the same terminal.</p> <p>Make selections at the digital operation panel with the function mode F-28 switch 3.</p> <p>* For analog meter use</p> <p>① Analog meter specification: 10V, 1mA full scale. Internal resistance: 10 to 22 kΩ.</p> <p>② Signal for analog meter use Digital duty control signal</p> <p>③ Meter reading adjustment is possible with M-ADJ. (Provided if the meter's internal resistance is 10 to 22 kΩ)</p> <p>* When the digital monitor (for frequency counter use) is selected.</p> <p>* Output signal is as indicated below.</p> 
Alarm output contact	AL0 AL1 AL2	<p>In case of B contact selected when in normal state: AL0-AL1 Closed</p> <p>When in abnormal state: AL0-AL2 closed, when the power supply is turned off.</p>	AL0 AL1 AL2	<p>When in abnormal state: AL0-AL1 Closed</p> <p>When in normal state: AL0 AL2 close, when the power supply is turned off.</p>

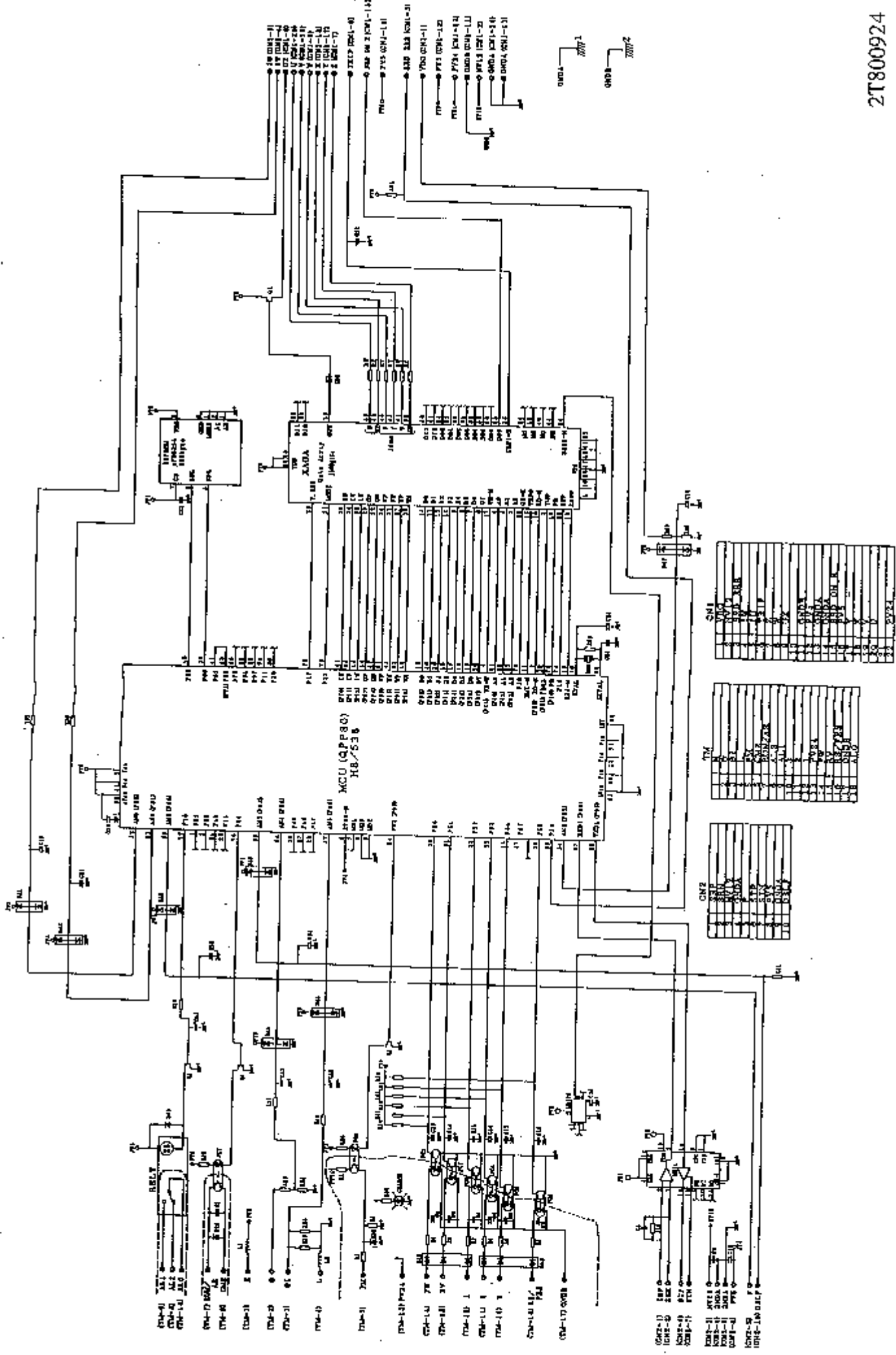

2T800924

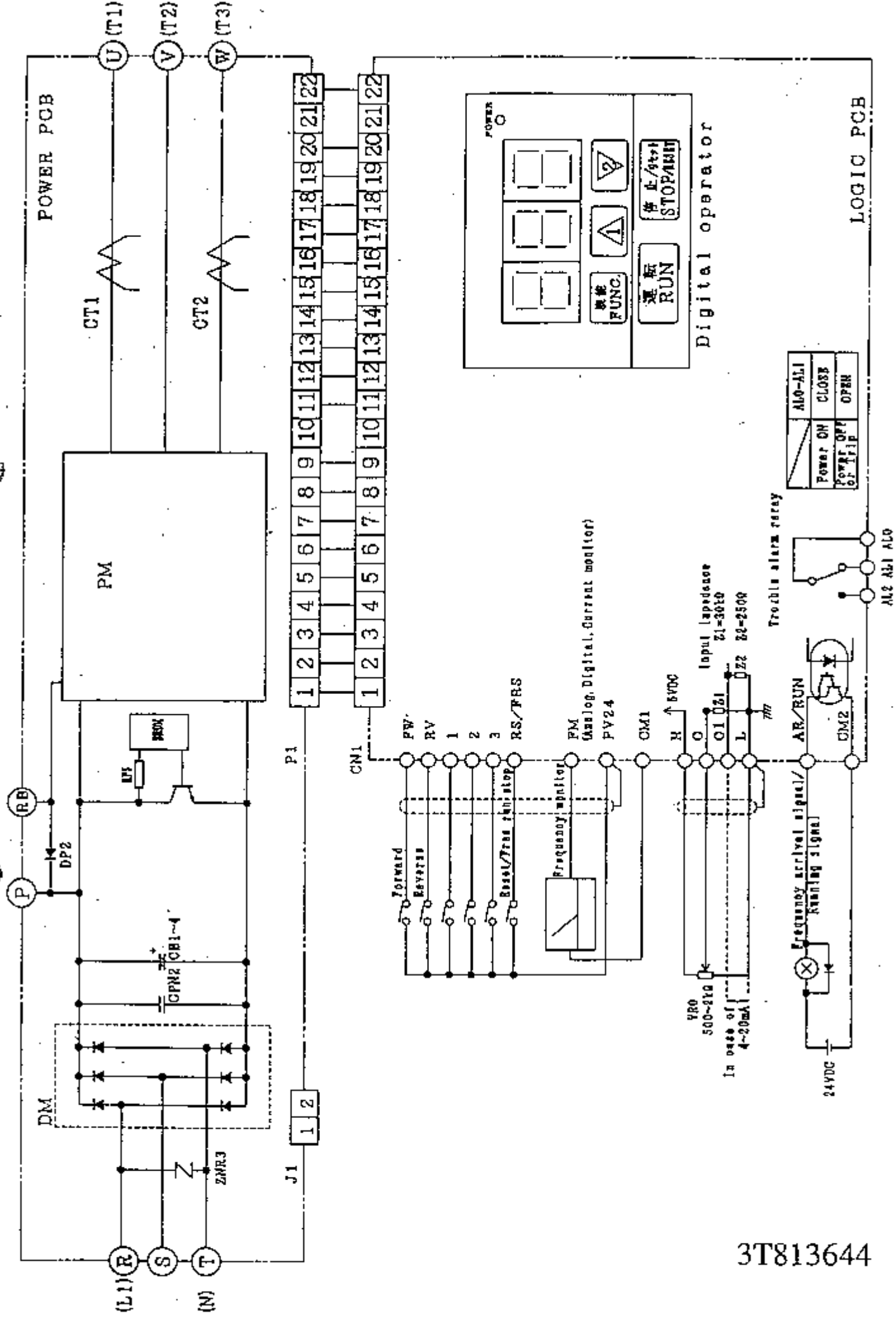

3T813644

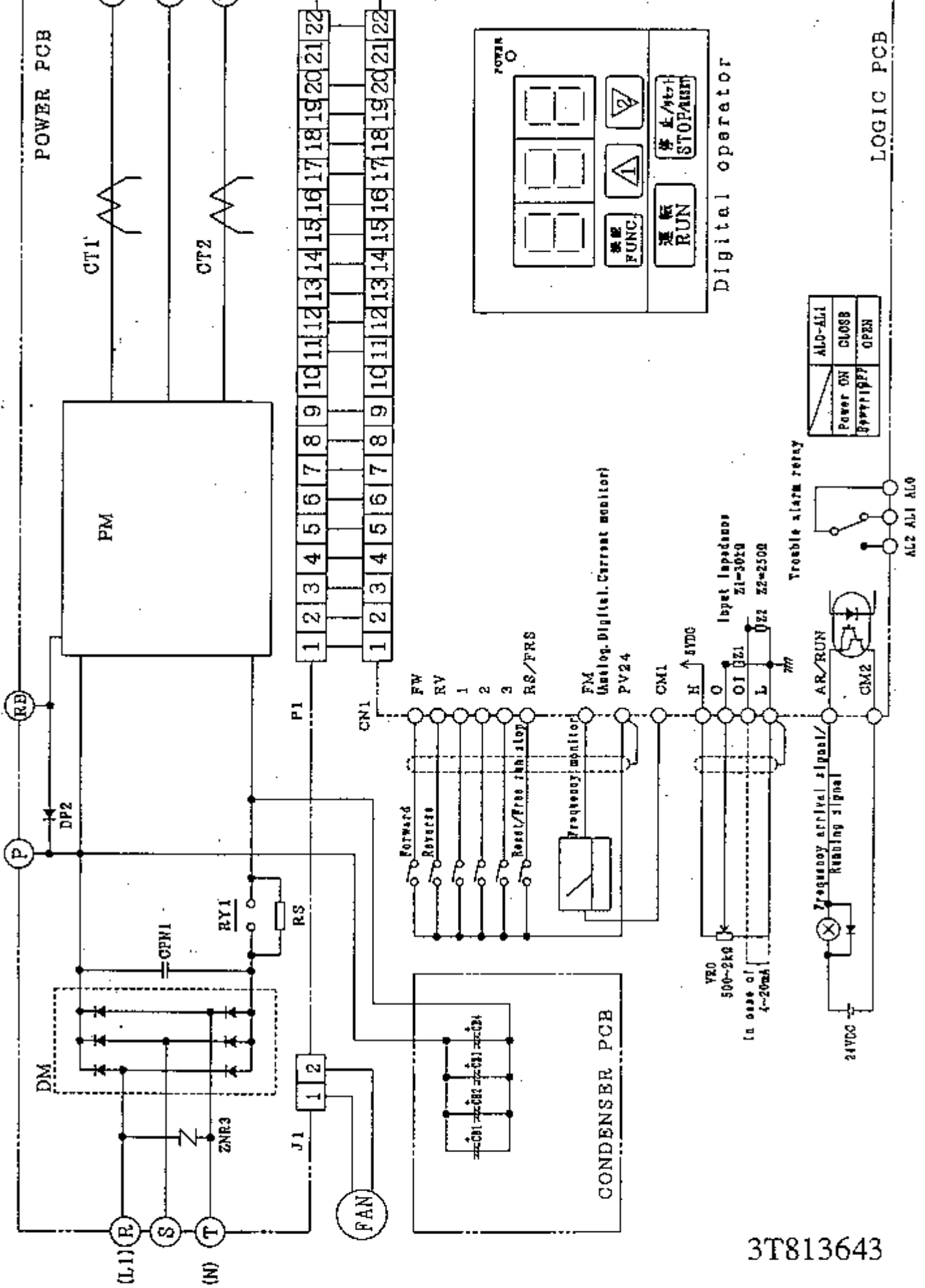

3T813643

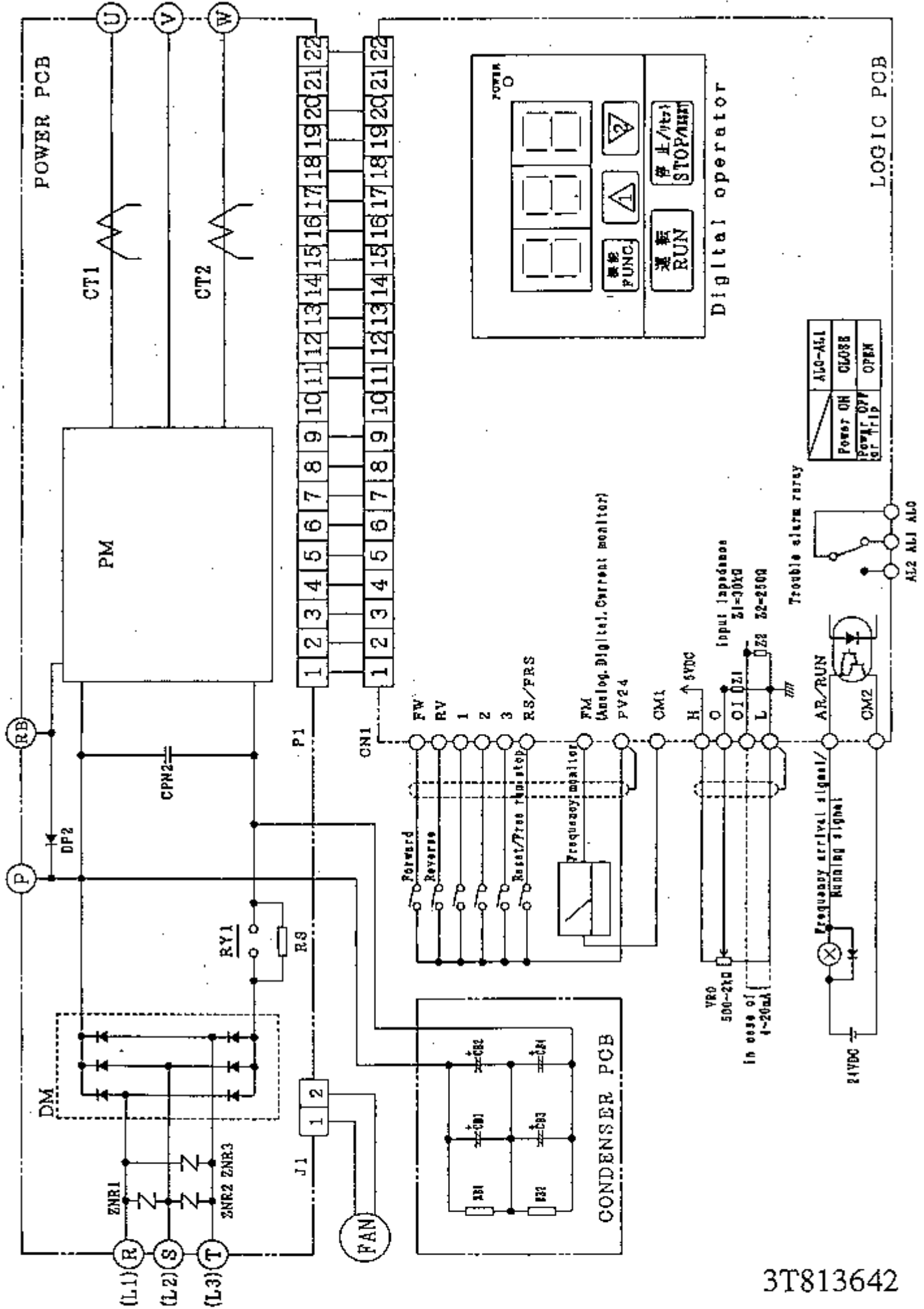

3T813642

Item No.	Part No.	Description	Qty. (see Inverter)
1	CS	Diecast case	1
2	PM	Inverter module	1
3	DM	Diode module	1
4	CV	Cover	1
5	CV	Blind cover (upper)	1
6	CV	Blind cover (lower)	1
7	CV	Front cover	1
8	PANEL	Digital operation panel	1
9			
10	PCB	Power PCB	1
11	PCB	Logic PCB	1
12			
25	FAN	Fan	1

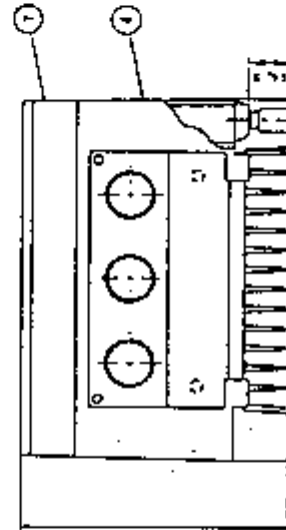
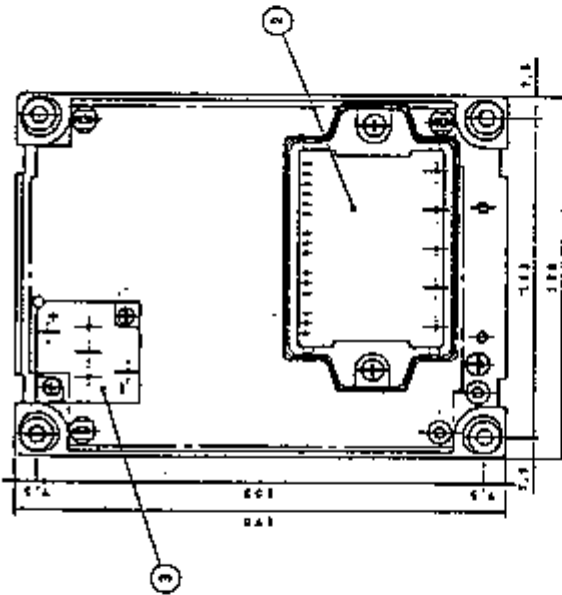
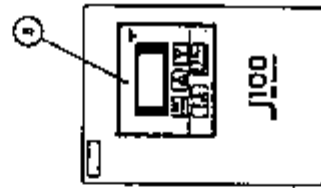
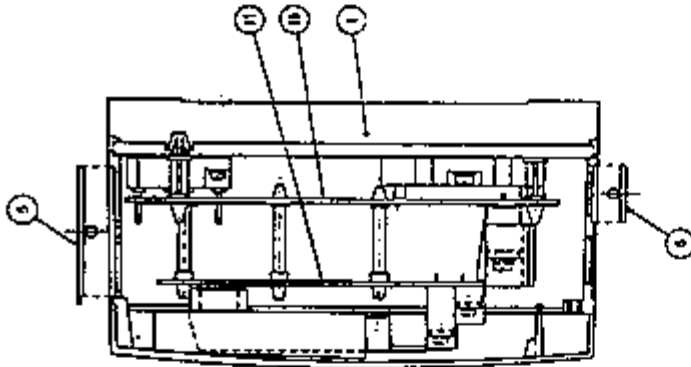

3T810495

Index No.	Part No.	Description	Qty (as described)
1	CS	Diecast case	1
2	PM	Inverter module	1
3	DM	Diode module	1
4	CV	Cover	1
5	CV	Blind cover (upper)	1
6	CV	Blind cover (lower)	1
7	CV	Front cover	1
8	PANEL	Digital operation panel	1
9	PL	Spacer	1
10	PCB	Power PCB	1
11	PCB	Logic PCB	1
12	PCB	Capacitor PCB	1
25	FAN	Fan	1

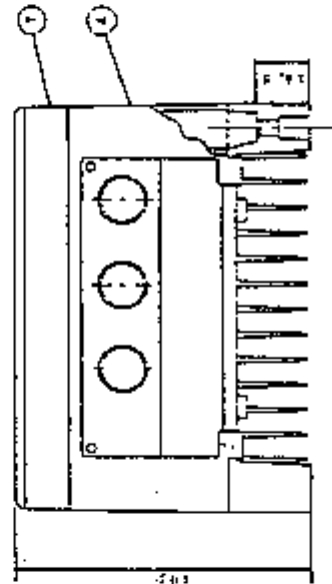
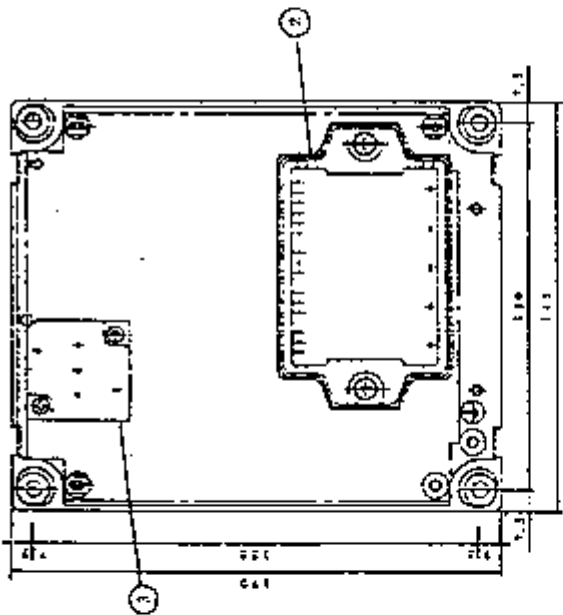
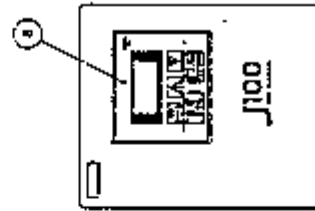
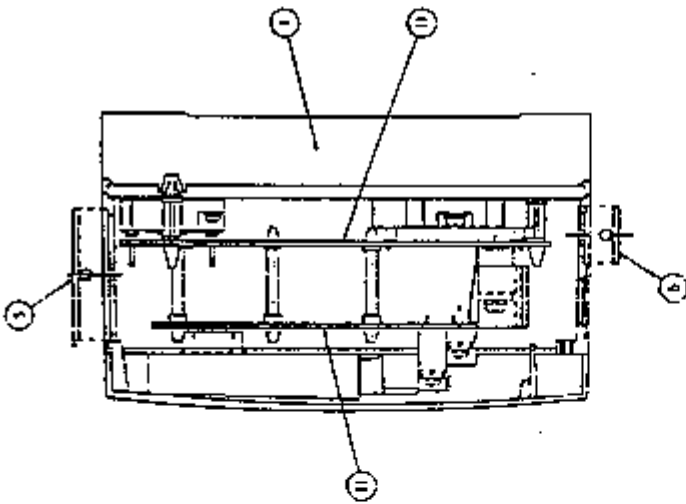

3T810496

Index No.	Part No.	Description
1	CS	Diecast case
2	PM	Inverter module
3	DM	Diode module
4	CV	Cover
5	CV	Blind cover (upper)
6	CV	Blind cover (lower)
7	CV	Front cover
8	PANEL	Digital operation panel
9	PL	Spacer
10	PCB	Power PCB
11	PCB	Logic PCB
12	PCB	Capacitor PCB
25	FAN	Fan

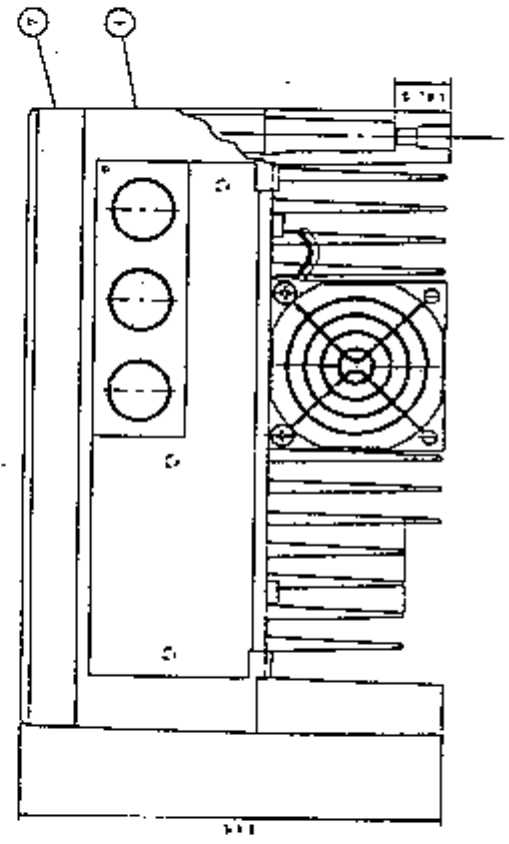
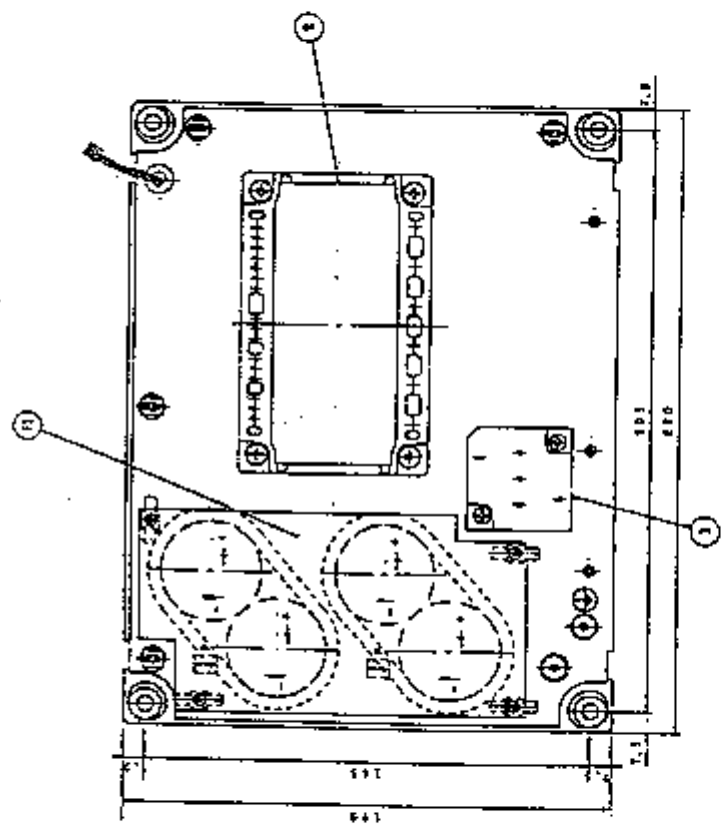
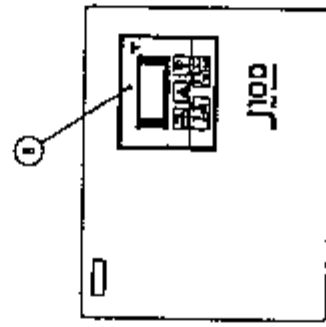
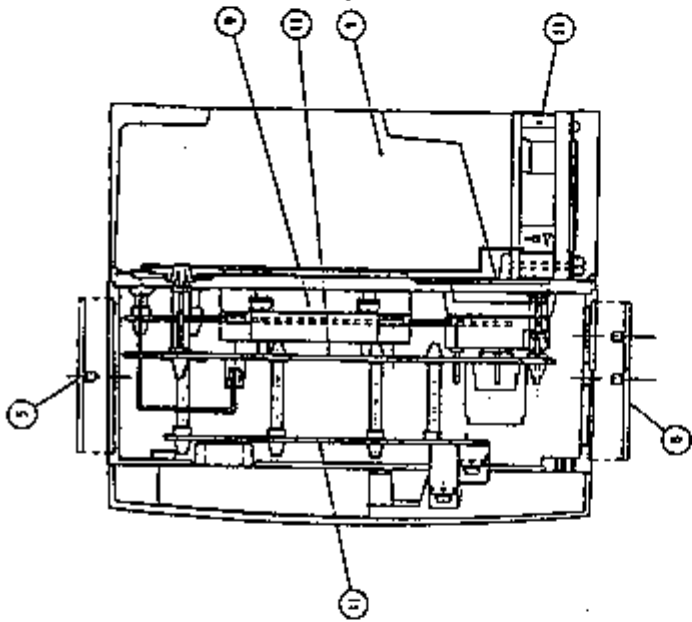

3T810498

Item No.	Part No.	Description
1	CS	Diecast case
2	PM	Inverter module
3	DM	E-Mode module
4	CV	Cover
5	CV	Blind cover (upper)
6	CV	Blind cover (lower)
7	CV	Front cover
8	PANEL	Digital operation panel
9		
10	PCB	Power PCB
11	PCB	Logic PCB
12	PCB	Capacitor PCB
25	FAN	Fan

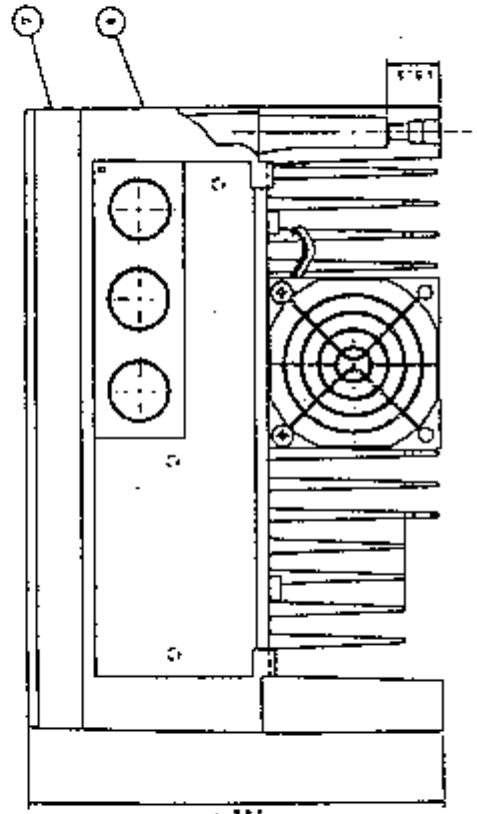
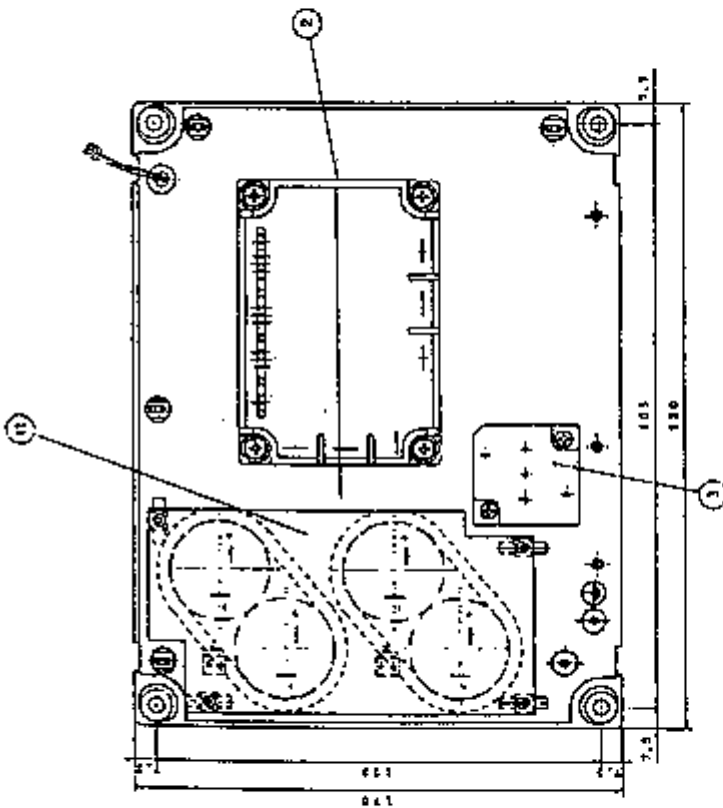
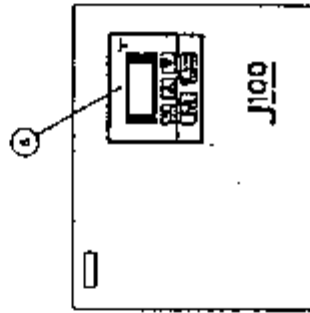
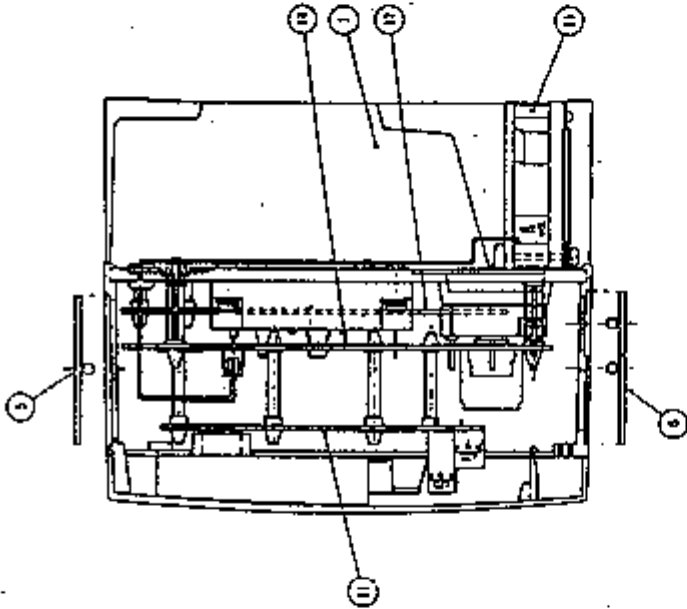

3T810499