

# A42M

## PHOTOELECTRIC MODULAR ROTARY ENCODER



Photoelectric rotary encoder A42M is used to establish an informational link between the key machine components, industrial robots, comparators and DCC, NC or Digital Readout Units. It provides information about the value and direction of the motion.

The encoder is used in automatic control, on-line gauging, process monitoring systems, etc.

The absence of bearings and lubricants makes the encoder suitable for use in vacuum environment or when zero starting torque is required.

The encoder consists of two assemblies: rotor/hub and scanning unit.

The hub unit includes the grating disc fixed to bushing made from stainless steel.

The scanning unit includes the base made of hard anodized aluminium.



The base supports light source, reticle, photodiodes and other electronic components.

The stator of the encoder is fixed to an object by means of screws. The hub is mounted directly on the shaft.

Three versions of output signals are available:

- A42M-A - sinusoidal signals, with amplitude approx. 11  $\mu$ App;
- A42M-AV - sinusoidal signals, with amplitude approx. 1Vpp;
- A42M-F - square-wave signals TTL.

### MECHANICAL DATA

Line number on disc (z)	1000, 2500 (others on request)
Number of output pulses per revolution for A42M-F	Z x k, where k=1,2,5,10
Max. permissible mechanical rotation speed	20000 rpm
Accuracy ( $T_1$ , period of lines on disc in arc. sec.)	$\pm 0.1T_1$ arc. sec.
Permissible axial shaft run out	0.05 mm
Hub inside diameter	10, 8, 6 mm
Rotor moment of inertia	< 22 gcm <sup>2</sup>

Protection (IEC 529)	IP00
Max. weight:	
- rotor assembly	0.022 kg
- scanning unit	0.04 kg
Operating temperature	-10...+70 °C
Storage temperature	-30...+85 °C
Maximum humidity (non-condensing)	98 %
Permissible vibration (55 to 2000 Hz)	$\leq 100$ m/s <sup>2</sup>
Permissible shock (6 ms)	$\leq 1000$ m/s <sup>2</sup>

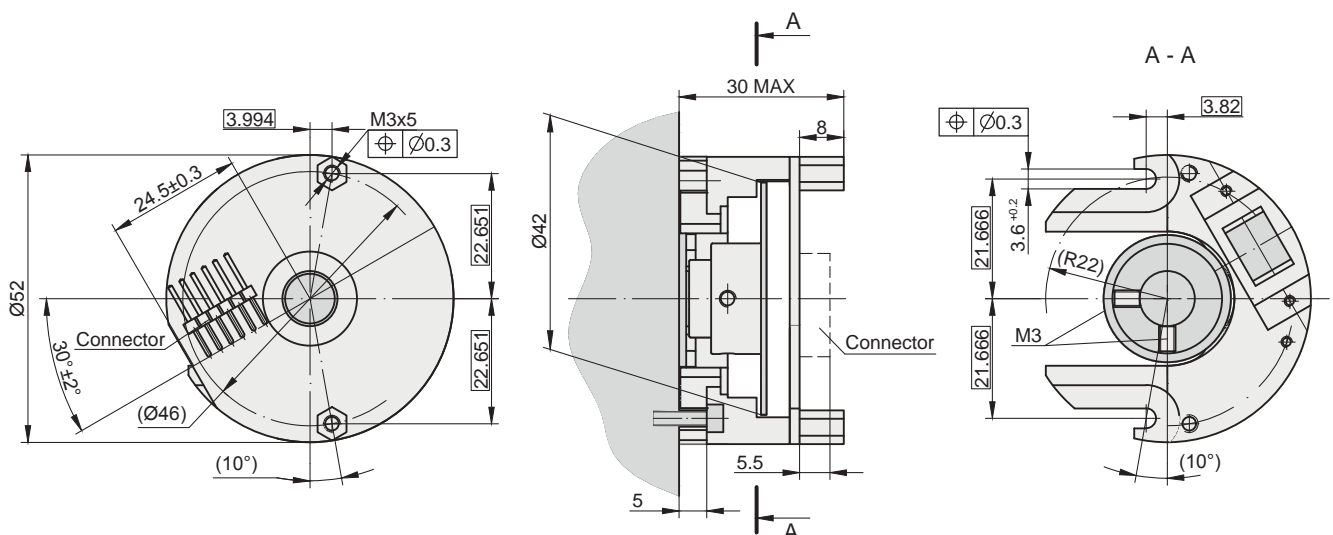

## ELECTRICAL DATA

VERSION	A42M-A $\sim 11 \mu\text{App}$	A42M-AV $\sim 1V \text{Ap}$	A42M-F $\square$ TTL
Power supply	+5 V $\pm$ 5% / < 80 mA	+5 V $\pm$ 5% / < 120 mA	+5 V $\pm$ 5% / < 120 mA
Light source	LED	LED	LED
Incremental signals	Two sinusoidal $I_1$ and $I_2$ Amplitude at 1 k $\Omega$ load: - $I_1 = 7\text{-}16 \mu\text{A}$ - $I_2 = 7\text{-}16 \mu\text{A}$	Differential sine +A/-A and +B/-B Amplitude at 120 $\Omega$ load: - A = 0.6-1.2 V - B = 0.6-1.2 V	Differential square-wave U1/ $\overline{U1}$ and U2/ $\overline{U2}$ . Signal levels at 20 mA load current: - low (logic "0") < 0.5 V - high (logic "1") > 2.4 V
Reference signal	One quasi-triangular $I_0$ peak per revolution. Signal magnitude 1 k $\Omega$ load: - $I_0 = 2\text{-}8 \mu\text{A}$ (usable)	One quasi-triangular +R and its complementary -R per revolution. Signals magnitude at 120 $\Omega$ load - R = 0.2-0.8 V (usable)	One differential square-wave U0/ $\overline{U0}$ per revolution. Signal levels at 20 mA load current: - low (logic "0") < 0.5 V - high (logic "1") > 2.4 V
Maximum operating frequency	(-3 dB) $\geq$ 160 kHz	(-3 dB) $\geq$ 180 kHz	(160 x k) kHz, k-interpolation factor
Direction of signals	$I_1$ lags $I_2$ for clockwise rotation (viewed from shaft side)	+B lags +A for clockwise rotation (viewed from shaft side)	U2 lags U1 with clockwise rotation (viewed from shaft side)
Maximum rise and fall time	-	-	< 0.5 $\mu\text{s}$
Recommended max. cable length to subsequent electronics	5 m	25 m	25 m
Output signals			

Note:

- Maximum working rotation speed (with proper encoder counting) is limited by maximum operating frequency and maximum mechanical rotation speed.
- If cable extension is used, power supply conductor cross-section should not be smaller than 0.5 mm<sup>2</sup>.

## MOUNTING DIMENSIONS

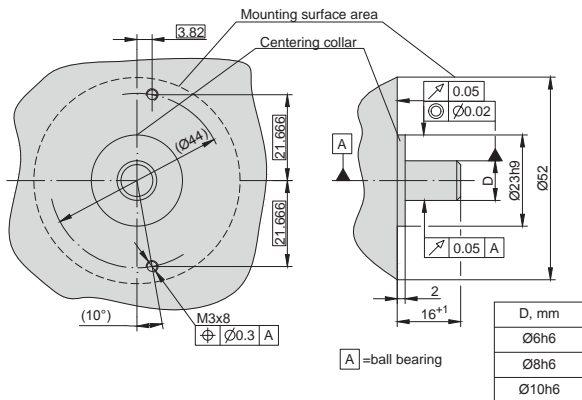

## PCB CONNECTOR

### AC

Adapter Cable dia.  
7 mm with PCB connector



## ACCESSORIES

<b>CONNECTORS FOR CABLE</b>	B12 12-pin round connector	C9 12-pin round connector	C12 12-pin round connector	D9 9-pin flat connector	D15 15-pin flat connector	RS10 10-pin round connector	ONC 10-pin round connector
<b>CONNECTOR FOR PCB</b>	Adapter Cable dia. 7 mm with PCB connector						
<b>DIGITAL READOUT DEVICES</b>	CS3000			CS5500			
<b>EXTERNAL INTERPOLATOR</b>	NK						

## ORDER FORM

OUTPUT SIGNAL VERSION:	PULSE NUMBER PER REVOLUTION:	(OPTIONAL) LINE NUMBER ON DISC (Z):	HUB INSIDE DIAMETER:	ADAPTER CABLE:	CONNECTOR TYPE FOR ADAPTER CABLE:
A AV F	1000 ... 25000	1000 2500 *only for A42M-F	06 - $\varnothing$ 6mm 08 - $\varnothing$ 8mm 10 - $\varnothing$ 10mm	W - without cable AC01 - 1m AC02 - 2m AC03 - 3m ...	W - without connector B12 - round, 12 pins C9 - round, 9 pins C12 - round, 12 pins D9 - flat, 9 pins D15 - flat, 15 pins RS10 - round, 10 pins ONC - round, 10 pins
ORDER EXAMPLES:	1) A42M-AV-2500-10-AC01/W 2) A42M-F-5000-06-W/W 3) A42M-F-5000/1000-06-W/W				