





**Головки резцедержательные
серии АК31**

Руководство по эксплуатации

**ООО НПО «Станкоресурс»
г. Днепропетровск
2012 г.**

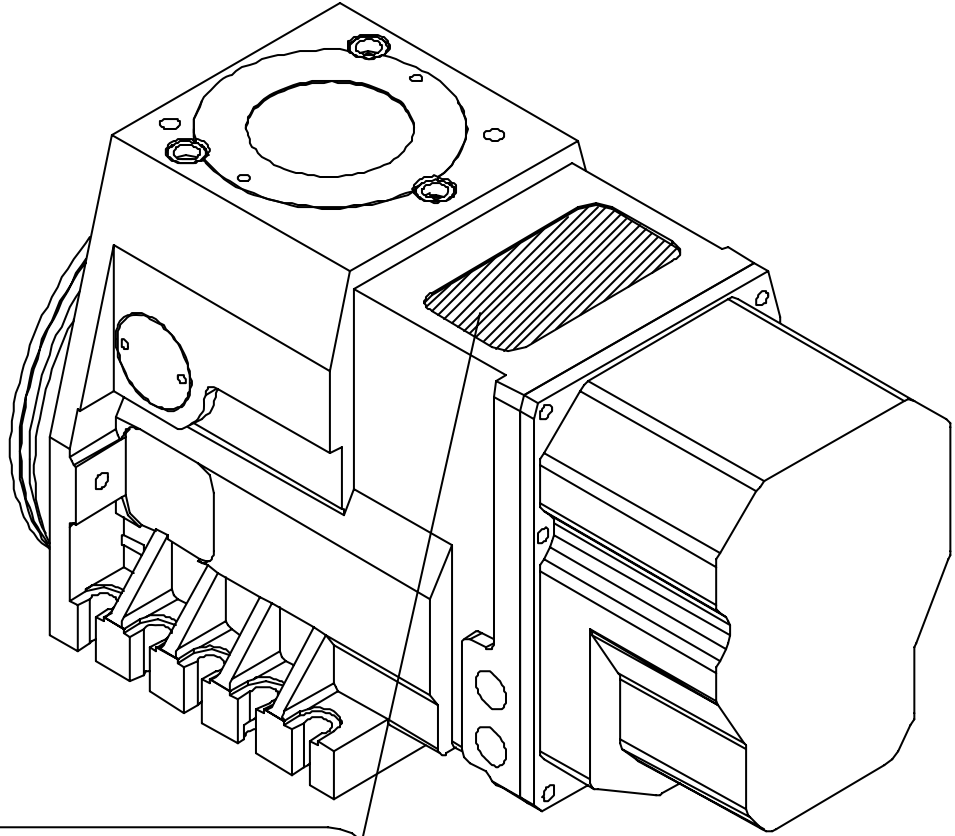
INDEX	1
IDENTIFICATION PLATE	2
BASIC SCHEME OF AK 31 SERIES TURRETS	3
MOUNTING THE TURRET ON THE MACHINE	4
LIQUID COOLANT FEED	5
MOUNTING THE TOOLHOLDER DISC ON THE TURRET	6
AREAS FOR DRILLING INTO THE CARCASE	7
ELECTRIC WIRING	8
CONNECTION AND LAYOUT OF ELECTRICAL COMPONENTS	9
OPERATION DIAGRAM	10
DESCRIPTION OF THE CYCLE	11
ELECTROMECHANICAL OPERATION OF THE TURRET	12
ELECTROMECHANICAL OPERATION OF THE TURRET	13
SECTIONAL VIEW	14
SECTIONAL VIEW	15
SECTIONAL VIEW	16
TO DISMANTLE THE TURRET COMPLETELY	17
TO DISMANTLE THE TURRET COMPLETELY	18
HINTS FOR REASSEMBLY	19
LUBRICATION	20
SUBSTITUTION OF THE COOLANT BUSHING	20
CHANGING THE MOTOR UNIT	21
SUBSTITUTION OF THE PREINDEXING ELECTROMAGNET	21
SUBSTITUTION OF THE BRAKE MAGNET AND ADJUSTMENT OF THE AIR GAP	21
SUBSTITUTION AND ADJUSTMENT OF THE ANGULAR ENCODER	22
SUBSTITUTION AND SETTING OF THE PREINDEXING PROXIMITY SWITCH	23
SUBSTITUTION AND SETTING OF THE LOCKING PROXIMITY SWITCH	24
OPERATIONS TO BE CARRIED OUT IN CASE THE POSITIONING CYCLE HAS NOT BEEN COMPLETED (because of an emergency or accidental stop)	25
PERIODICAL CHECKS	26
RECOMMENDED SPARE PARTS	27
TABLE OF DATA	28
PERFORMANCE DIAGRAMS	29
PROBLEMS AND REMEDIES	30
PROBLEMS AND REMEDIES	31
PROBLEMS AND REMEDIES	32



 NC TURRET
AK _____
Serial No. _____ Date _____
YANTAI UNIVERSAL MACHINE TOOL
ACCESSORY GROUP Co.,LTD PRC

The turret consist of a fixed part (carcase) containing the mechanism and a moving part (rotating crown) to which the tool holder disc is attached.

The axis of rotation of the disc is parallel to the plane of the base of the carcase.

AK31series turrets, normally made with 8 or 12 divisions, change station by rotating in either direction, clockwise or anticlockwise.

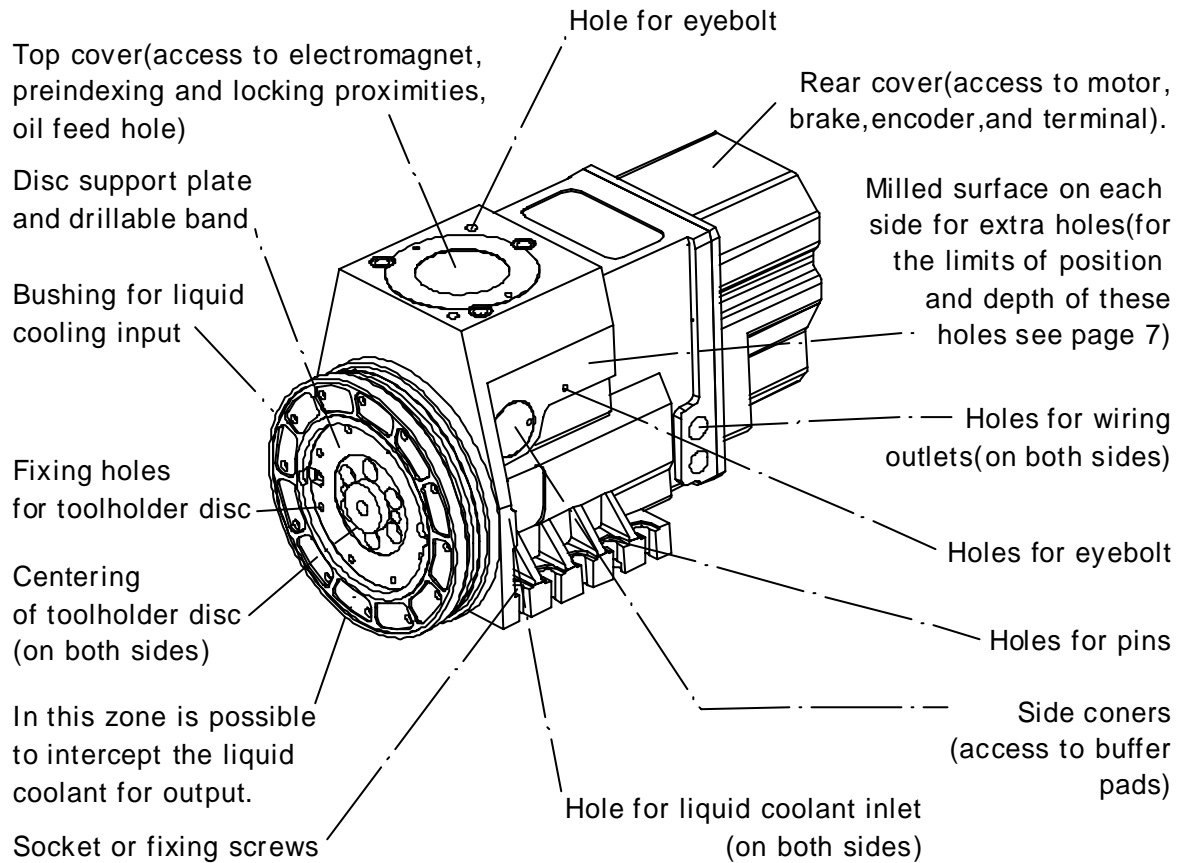

Turret size	Diameter holes for ringbolts	Diameter holes for wiring output
AK3163	M12	M20X1.5
AK3180	M12	M20X1.5
AK31100	M10	M24X1.5
AK31125	M12	M24X1.5
AK31160	M27	M24X1.5
AK31200	M30	M24X1.5

The surface on which the turret is to be mounted must be clean, without marks due to accidental knocks, and be truly plane within 0.01/100mm.

If necessary adapt the height by inserting a shim under the base of the turret.

With the fixing screws not quite tight line up the turret, that is to say the toolholder disc, with the mandrel axis. Then tighten down the fixing screws and mark and drill the holes for the pinning between carcass and slide.

The pins need not to be actually inserted, but will be useful for realignment if the turret should move relative to the slide as a result of an accidental blow.

IMPORTANT

All checks of alignment and height of turret or of the toolholder disc must be made with turret locked.

Failure to lock the turret may cause errors in setting.

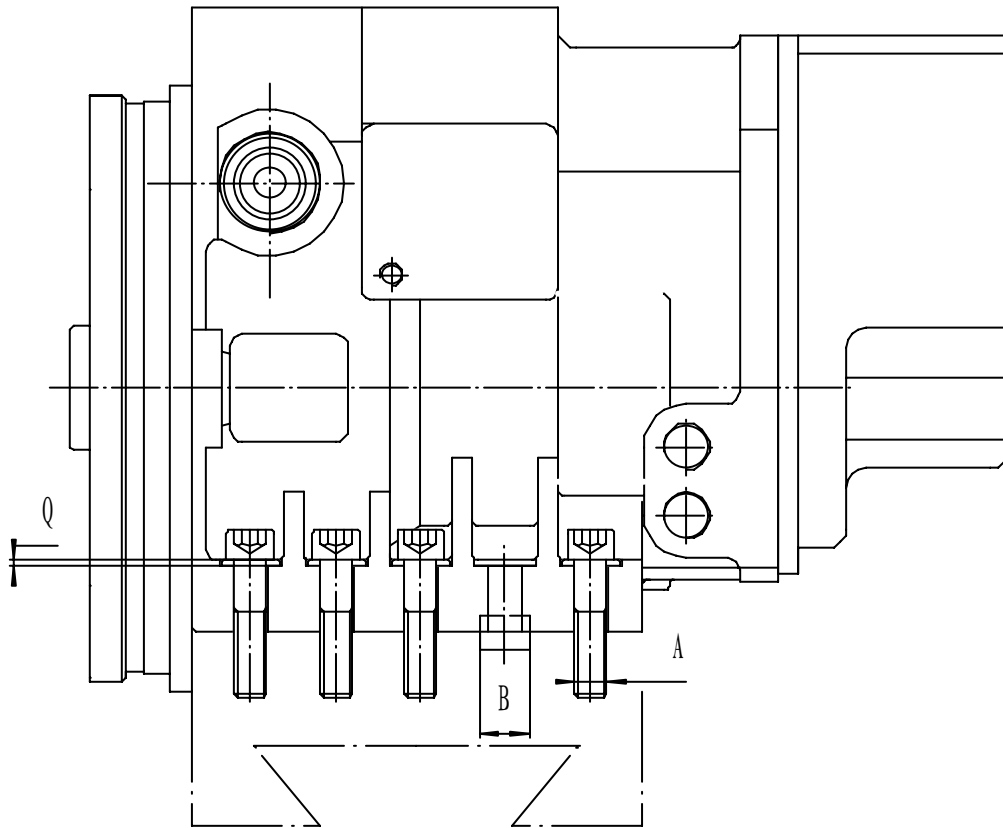

Turret size	Diam. A	Diam. B (mm)	Thickness washer Q(mm)
AK3163	M8	8	6
AK3180	M10	10	6
AK31100	M12	10	8
AK31125	M16	12	8
AK31160	M20	14	10
AK31200	M24	16	10

Two holes are provided on two sides of the carcass for the supply of liquid coolant .The feed pipe has to be connected in either one of the two, the not utilized hole for the liquid coolant inlet must be plugged.

The drilled bush (033) must be mounted on the hole where it is foreseen the liquid coolant outlet on the toolholders disc; the other bush (033a not drilled) must be mounted on the other hole.

One spring for both bushes presses against the internal surface of the distributor disc on which will lean the rear surface of the toolholders disc provided with drilling made in correspondence with the interception area of the distributor disc, area in which it is possible to make the coolant interception holes.

■ Position of the pipe for liquid coolant interception

▲ Area in which is possible to make liquid coolant interception on the 8 Or 12 positions toolholder disc in the "A" or in the "B" version

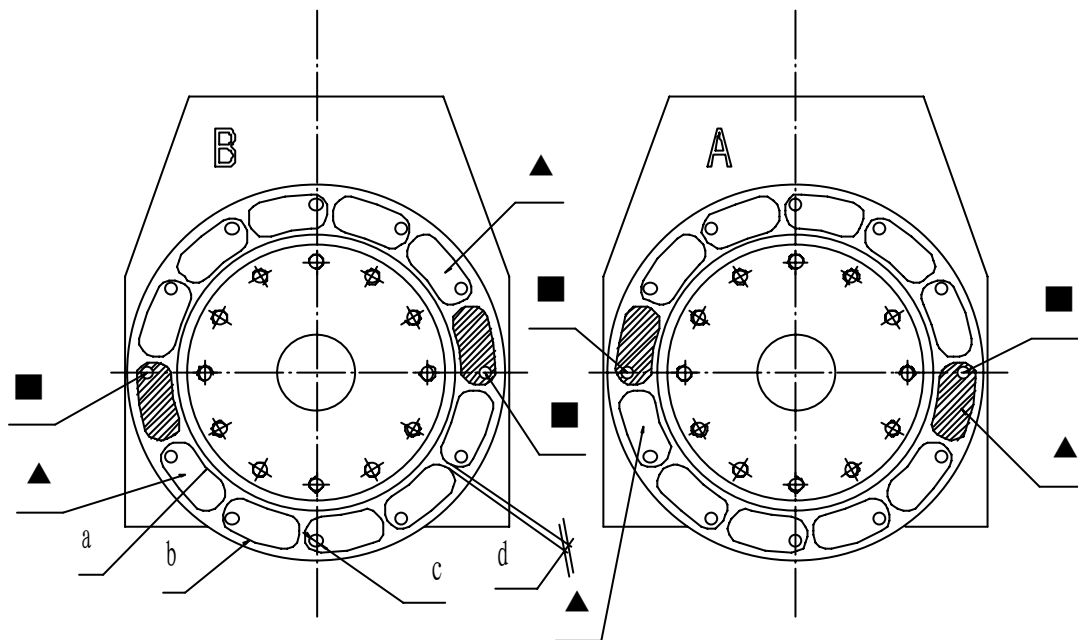

Turret size	a	b	c	d	e° (grad.)
AK3163	124	166	6	1.5	24°
AK3180	153	200	7	2	25°
AK31100	186	237	8	2	25°
AK31125	226	292	11	2	25°30'
AK31160	308	373	14	2	25°30'
AK31200	390	452	14	2	26°15'

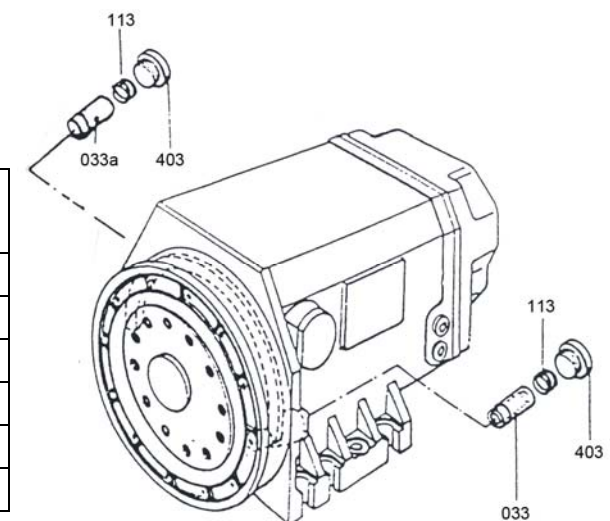

The toolholder disc is mounted and fixed to the turret with screws. Its orientation is decided by suitable drilling and pinning.

The pins need not to be actually inserted, but will be useful for realignment if an accidental knock should lift the toolholder disc relative to the rotating crown.

The maximum permissible depth of holes drilled in the rotating crown, and the area which can be used for them, are indicated below.

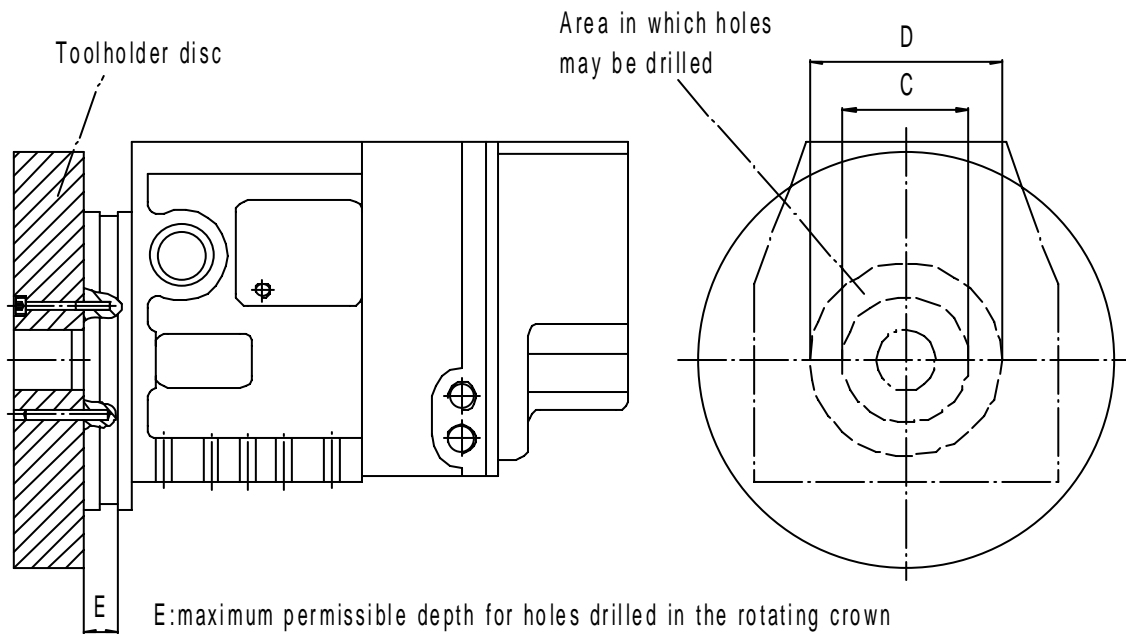

Turret size	C mm	D mm	E mm
AK3163	82	98	15
AK3180	88	128	15
AK31100	110	156	20
AK31125	130	194	20
AK31160	170	240	30
AK31200	240	320	30

Milled flats are present on each side of the carcass if it should be necessary to drill holes for any reason. The maximum permissible depth of such holes is shown in the table below, together with the dimensions and position of the flats.

AK3163,AK3180,AK31100,
AK31125,AK31160

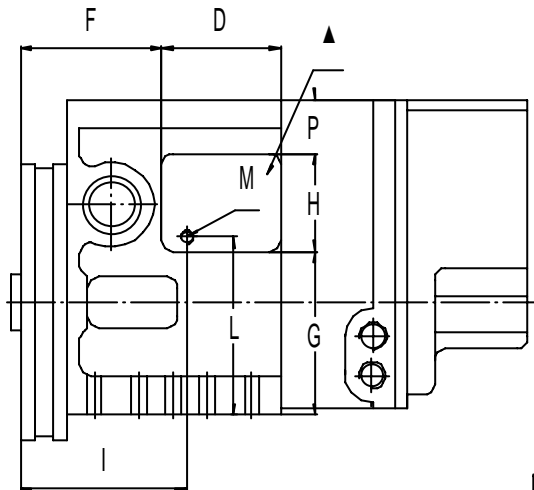

AK31200

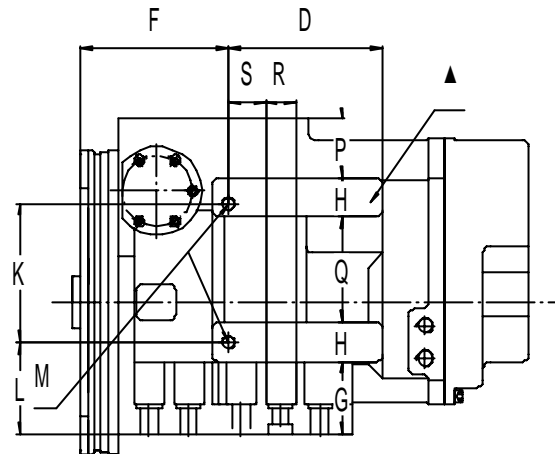

Turret size	F	G	H	I	K	L	M	N	O	P	Q	R	S
AK3163	110.5	103	60	118	--	110	M8	16	95	50	--	--	--
AK3180	111	120	60	126	--	130	M8	14	95	60	--	--	--
AK31100	131	145	37.5	139	--	153	M10	17.5	100	47.5	--	--	--
AK31125	142	170	90	154	--	183	M12	18	100	60	--	--	--
AK31160	193.5	220	100	211	--	237.5	M20	33	200	90	--	--	--
AK31200	222	110	60	227	190	140	M30	40	260	90	160	42	82

Wiring inside the turret must be executed according to the scheme on sheet 9.

Wiring must be arranged carefully so that they cannot be damaged or stripped in any way, particularly when finally closing the rear cover 011. Suitable anchoring brands are provided for this reason below the terminal blocks and we recommend their use, and their substitution with new ones in case of deterioration.

The wires must be kept close to the edge of the turret, any slackness being tucked away in safe spaces and fixed back with bands.

The sides of the turret each have two threaded holes for the electric cables and reception of their protective conduits. The unions and the conduits must be arranged and fixed in such a way as to ensure that the liquid coolant cannot possibly penetrate into the inside of the turret.

Any holes not used for passage of cable must be hermetically sealed

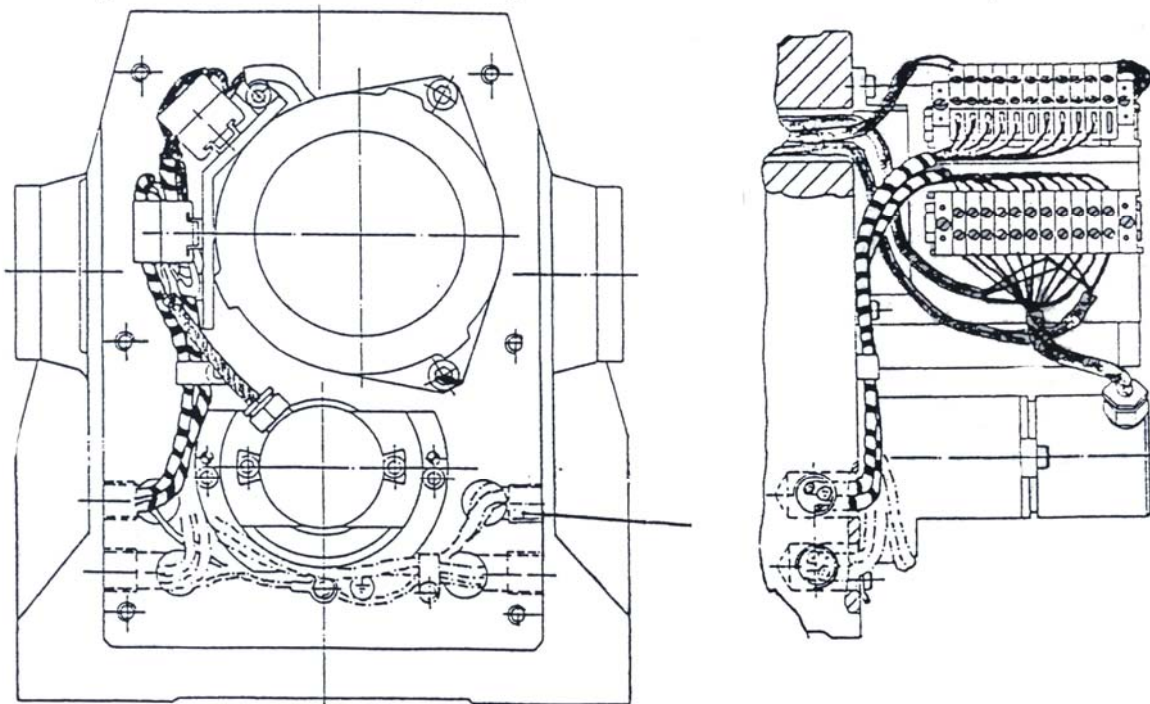

After having finished the wiring carry out the test of correct phase connection on the AC motor

(see sheet 21)

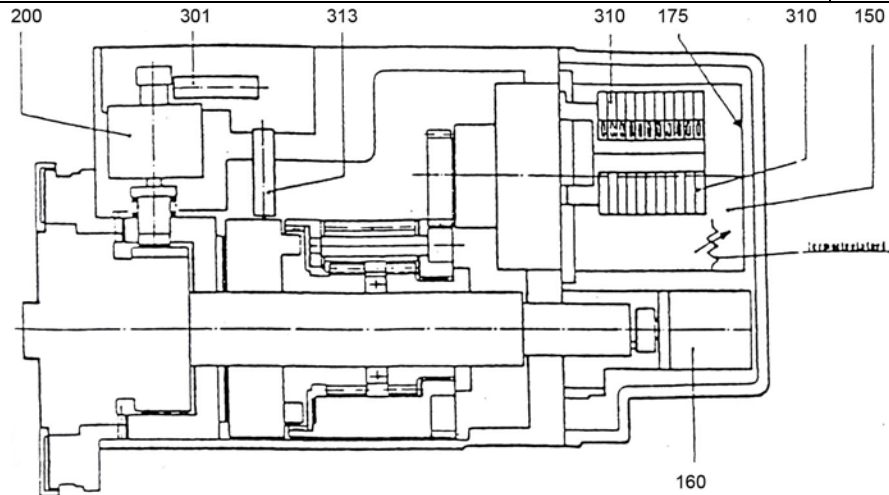

Ref.	Component/characteristic	Colours/connections internal terminal block	Type/notes
160	ABSOLUTE ENCODER binary code	1 Bit White 1 2 Bit Yellow 2 3 Bit Green 3 4 Bit Violet 4 parity Red 5 Strobe Black 6 + 24 Volt Brown 7 0 Volt Blue 8 Screen Yellow-Green 9	ENCODER mode 1 OBC 10 DC 24V ripple 10% PNP outlet 50 mA screened cable
	301	PREINDEXING + 24 Volt Brown 7 PROXIMITY 0 Volt Blue 8 switch output Black 10	12 mm D/A PNP NO outlet 300 mA
	313	LOCKING + 24 Volt Brown 7 PROXIMITY 0 Volt Blue 8 switch output Black 11	
	200	PREINDEXING 24 V DC Orange 12 ELECTROMAGNET 24 V DC Orange 13	60 Watt
		PTC THERMISTORS 120 C Grey 14 heat sensor Grey 15	R cold <1 Kohm R hot > Kohm
	175	BRAKE 24 V DC Black 16 24 V DC Black 17	15 Watt
	150	3 PHASE MOTOR 110 V 3 x black XYZ 18 50/60 Hz Red U Red V Red W	other voltages on request
		EARTH (gnd) WIRE Yellow-Green	

For more details about electrical components, see the electrical instructions supplied with each turret.

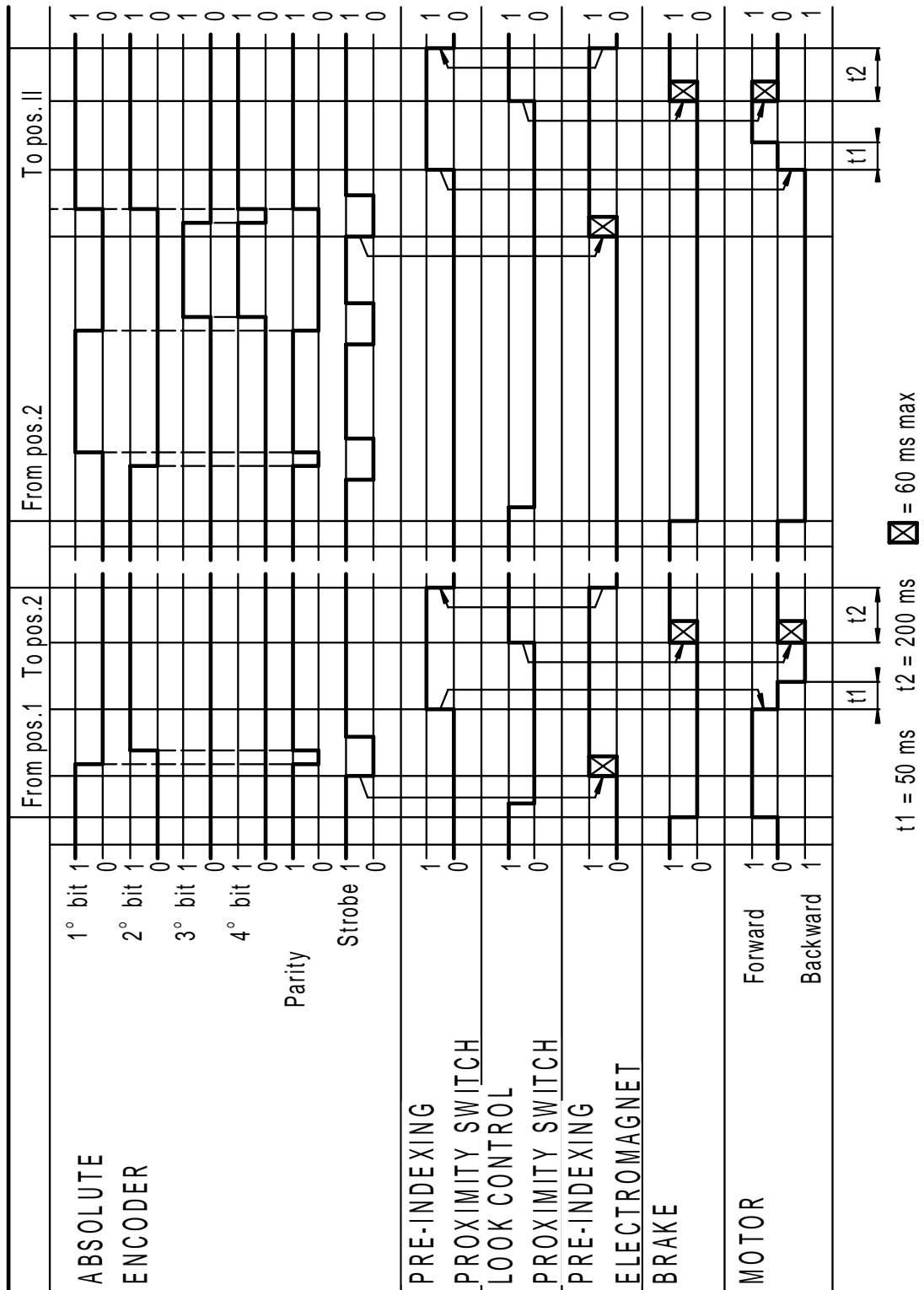

The operation diagram on sheet 10 shows ,as an example ,the sequence followed in passing from position 1 to position 2 going clockwise (when looking at the face of the toolholder disc on the turret) and from position 2 to position 11 going anticlockwise.

The sequence starts by automatically instructing: disconnect the brake and supply current to the motor for rotation in the chosen direction. Wait for the descending front of the strobe signal from the station before the one required, and then excite the preindexing electromagnet in as short a time as possible (maximum delay 60ms)

With the electromagnet excited, wait for the signal from the preindexing proximity control that confirms that rotation has been stopped by the indexing boss. At this signal, immediately stops the motor and ,after a 50 ms delay, reverse its rotation direction.

Then wait for the signal from the locking proximity control, cut off the motor as quickly as possible and excite the brake (maximum delay allowed 60 ms)

At this point it is possible, as a precaution, check the position and confirm that work may start, and then deactivate the electromagnet after a pause of 200 ms.

The delays are those measured directly on the appliances which constitute the turret.

ENCOOER CODE TABLE

<i>POSITION</i>	<i>A</i>	<i>B</i>	<i>C</i>	<i>D</i>	<i>PARITY</i>	<i>STROBE</i>
1	■				■	■
2		■			■	■
3	■	■				■
4			■		■	■
5	■		■			■
6		■	■			■
7	■	■	■		■	■
8				■	■	■
9	■			■		■
10		■		■		■
11	■	■		■	■	■
12			■	■		■

ORIGINAL SHUT—DOWN STATE OF THE TURRET

-brake connected
 -motor disconnected
 -electromagnet disconnected
 -rotating crown 003 linked up to the fixed crown 002 through the shortcircuiting crown 004. The dished springs press, by means of three rollers on three cam ends of the shortcircuiting crown, keeping the Hirth teeth of the crown in contract.

SEQUENCE FOR A CHANGING OF POSITION:

-electricity is cut off from the brake and connected to the motor which, through reduction stages (the first coaxial and the second epicycloid), starts rotating the planetary roller ring 006 which stops, after a preset angle, against a positive stop.

During this phase the central spring 034 pushes the shortcircuiting crown back, causing the cam ends of the rollers to descend and thus disconnect the movable crown which is then made to rotate by the pinion 008. Nearing the destination station, on the signal given by the angular encoder 160, the electromagnet 200 is excited and pushes the catch 017 to make it enter the appropriate pre-positioning recess in the divider 005 thus stopping the rotation of the crown and the associated toolholder disc. The resulting shock is absorbed by the buffer pads 032. The completion of the insertion of the catch into the recess and consequent stopping of the rotation of the disc is signaled by the preindexing proximity switch 301.

Arrival of this signal causes the rotation of the motor, and thus also of the planetary roller ring, to be reversed; so that the rollers rise on their cam ends push the shortcircuiting crown ahead, causing the Hirth teeth to engage. Passage of the external profile (i) of the planetary roller ring 006 activates the looking proximity switch 313, indicating that the turret is closed, or, in other words, that the rollers are on the extreme end of the cams.

When this signal arrives current is cut off from the motor and the brake goes into action to stop it. Immediately afterwards the electromagnet is deactivated, and consequently the catch is pushed out of the recess in the divider by the spring 047.

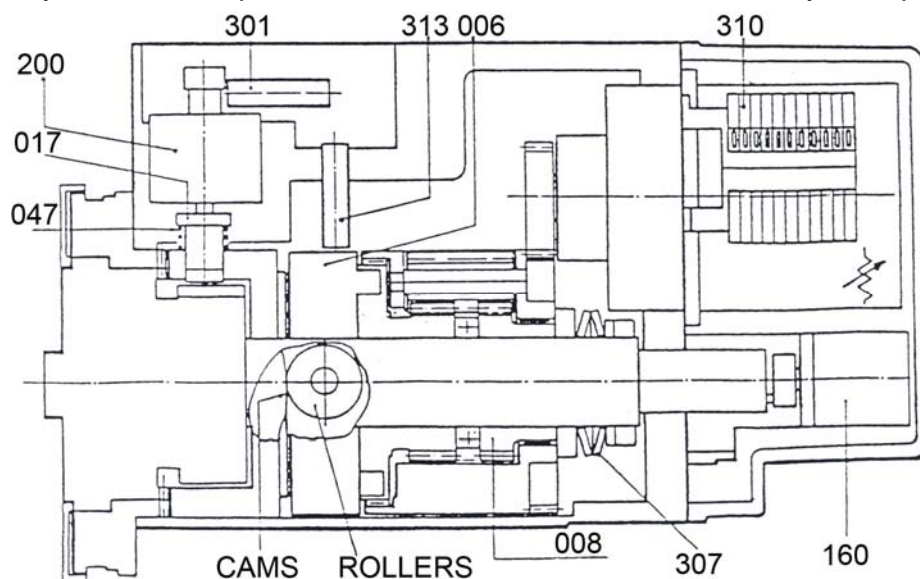

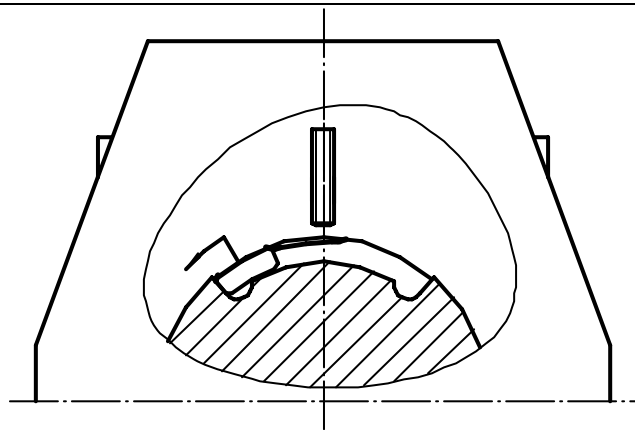
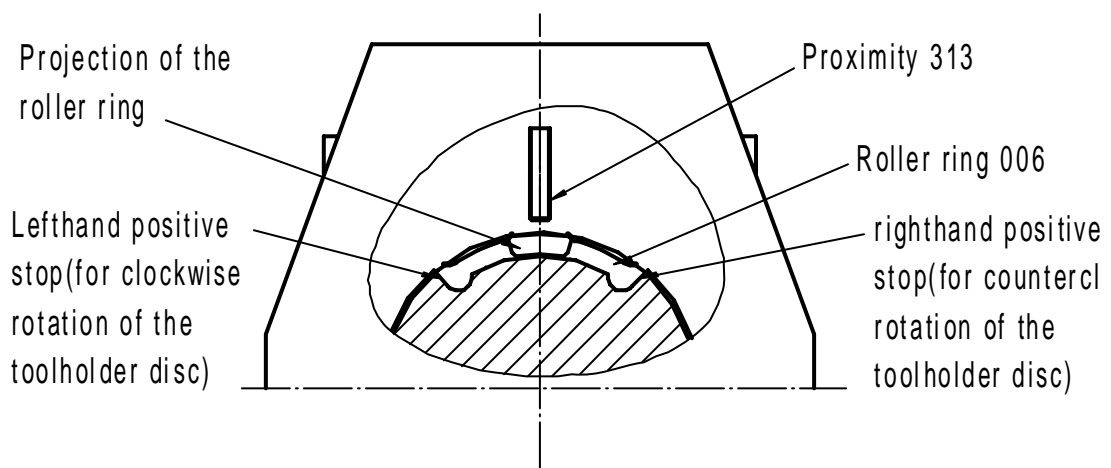

Turret unlocked (rollers on the bottom of the cam; Hirth teeth disengaged.)

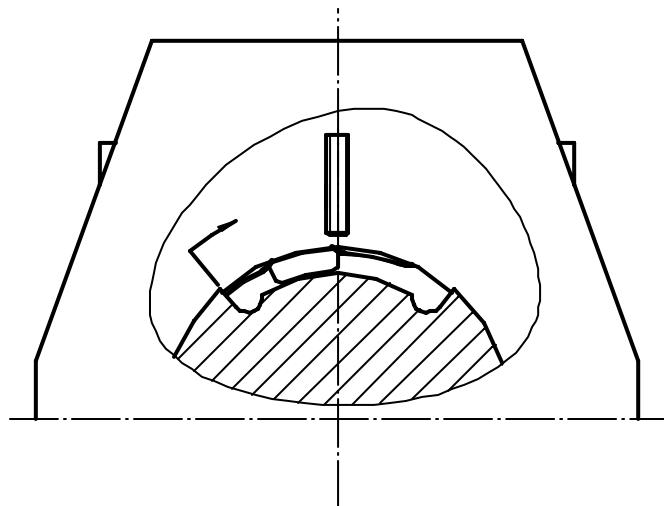

Turret locked (rollers at the beginning of the high level part of the cam) Proximity sw. 313 triggers

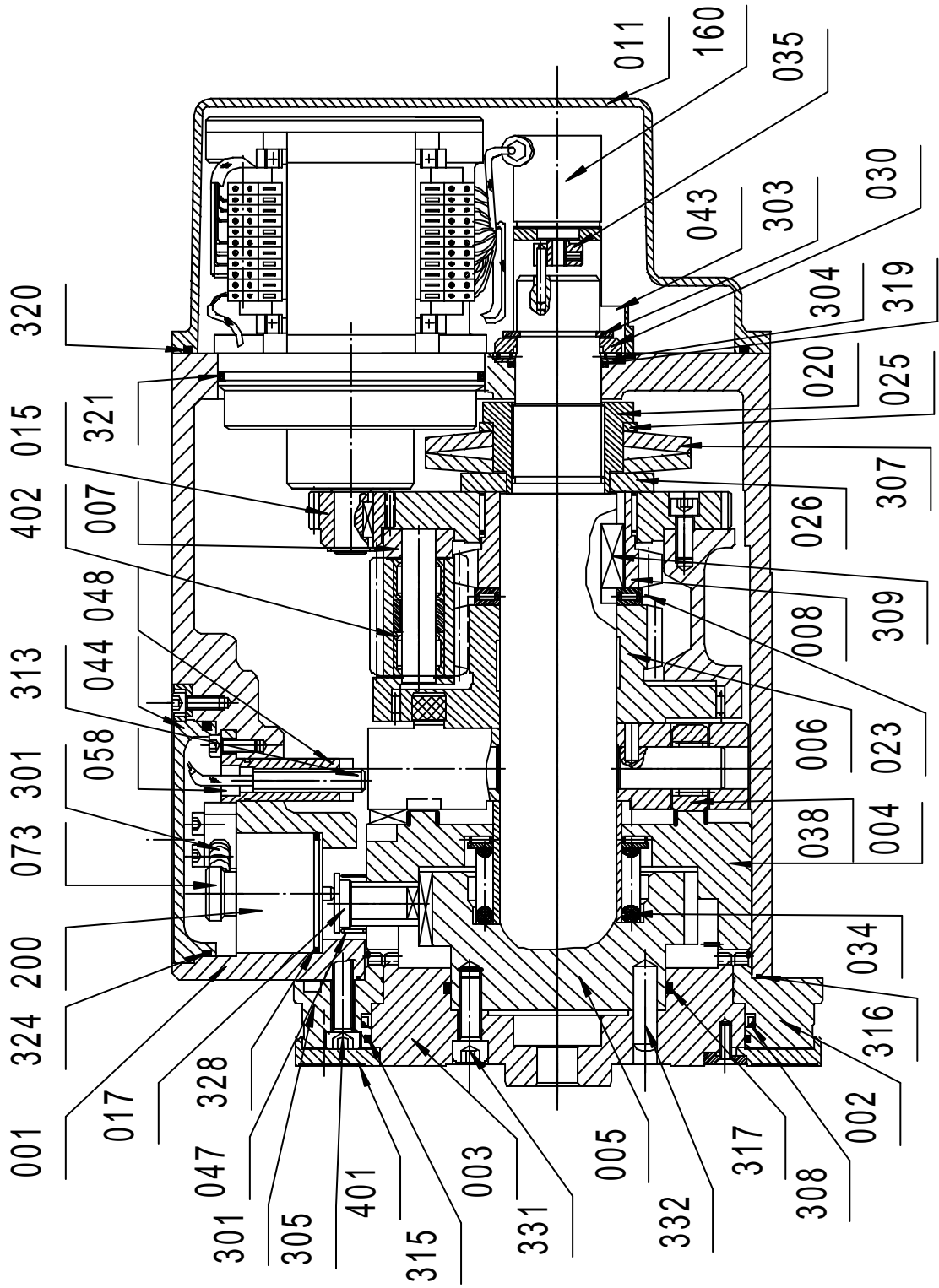

OIL LOADING HOLE

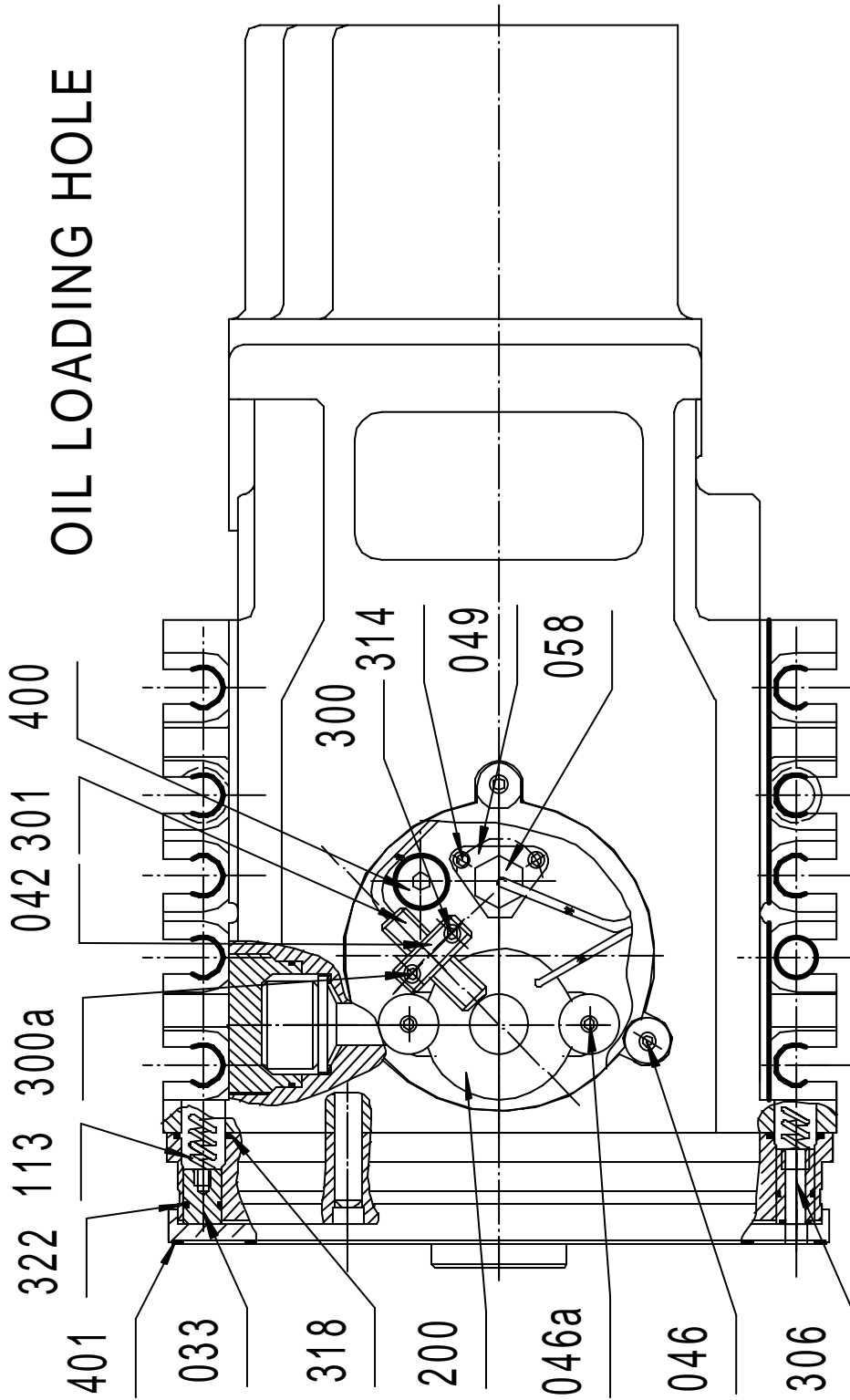

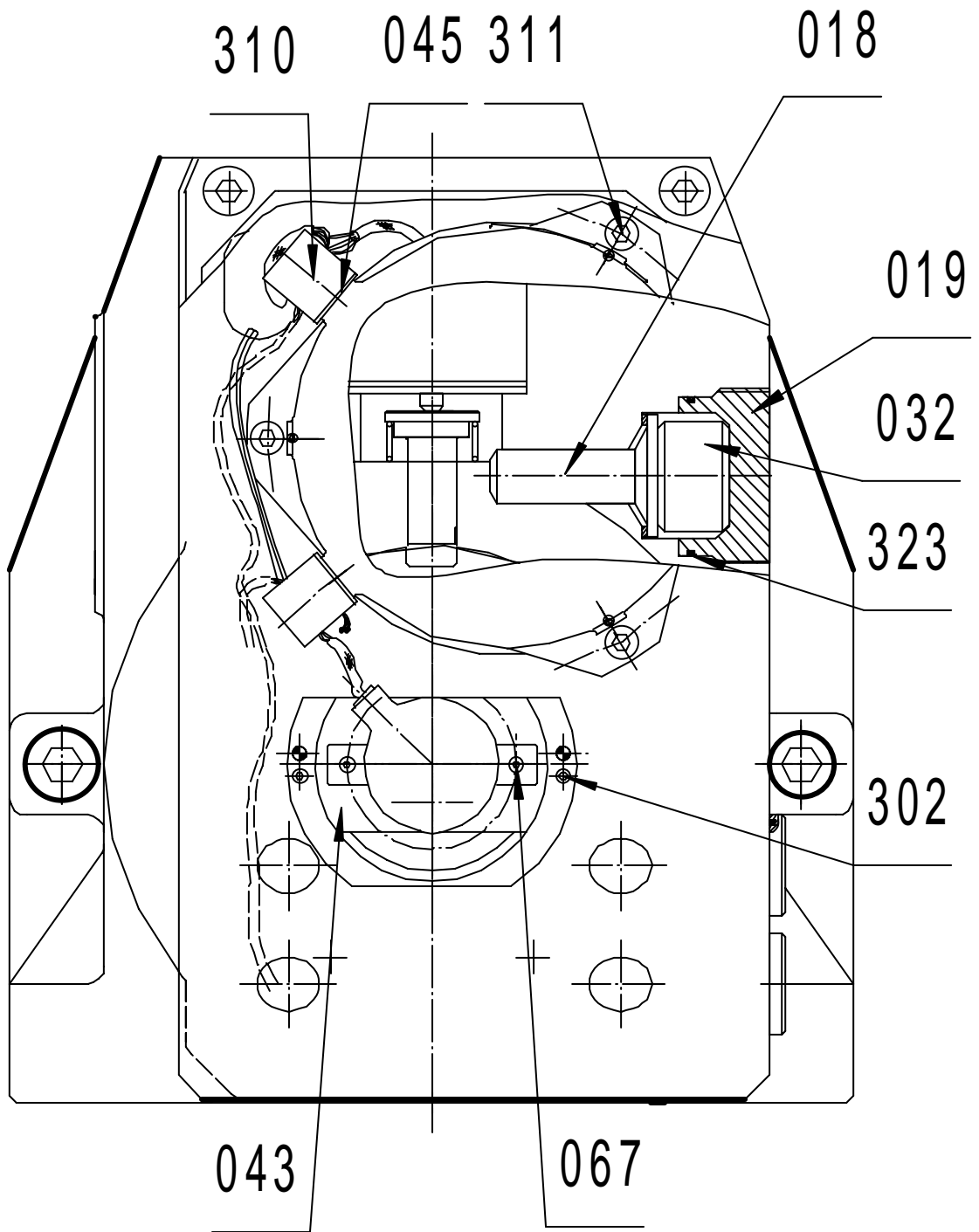

FROM ABOVE

Remove the washers 046, remove the top cover 044. Unscrew the screws 300, extract the Proximity switch support 042 complete with its proximity switch 301. Take off the support 049 complete with the proximity switch 313, remove the washers 046a, extract the electromagnet 200, take out the catch 017 with its spring 047. Take the two covers 019 off the sides and extract the Buffer plungers 018 together with the pads 032.

FROM THE REAR

Take off cover 011, unscrew the screws 302, and remove encoder support 043 together with the encoder 160, take off the circlip 303, remove the thrust race 030 and the bearing 304.

FROM THE FRONT

Remove the distributor disc 404, remove the toolholder disc, unscrew the screws 305, extract the pins 306, take out the entire central sub-assembly composed of rotating crown 003, the divider 005, the roller ring 006 the satellite carrier 007, the ring nut 020, the dished spring 307, and the distance pieces 025-026. If it is necessary to dismantle this sub-assembly also, first unscrew the ring nut with a suitable tool, and then take off all the other components.

Turret Size	Diameter R (mm)	diameter S (mm)
AK3163	44	8.3
AK3180	44	8.3
AK31100	56	8.25
AK31125	56	8.25
AK31160	100	10
AK31200	100	10

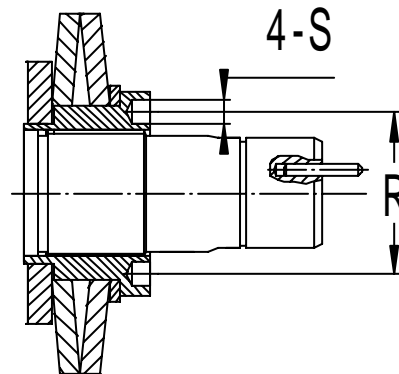

Whenever the turret is dismantled inspect the following parts and replace them if worn or broken:

- Main gasket 308
- All sealing rings (O-ring type)
- Buffer pads 032

and also (only if the central sub-assembly has been completely dismantled) the following parts :

- Cam surfaces
- Rollers
- Hirth teeth
- All gears
- Contacts surface between rotating crown 003 and fixed crown 002

If any of the parts composing the central sub-assembly (except the satellite carrier 007) has to be substituted it is necessary on reassembly to check and reset the distances T and U which determine the correct loading of the springs .

-Reassemble the parts, as shown in the figure, with the Hirth teeth in contact and the rollers sitting on the raised parts of the cams, check that the value of T is inside of the range indicated (0.2-0.25mm). If it is not then grind new races 023 to bring the value of T within the prescribed tolerance.

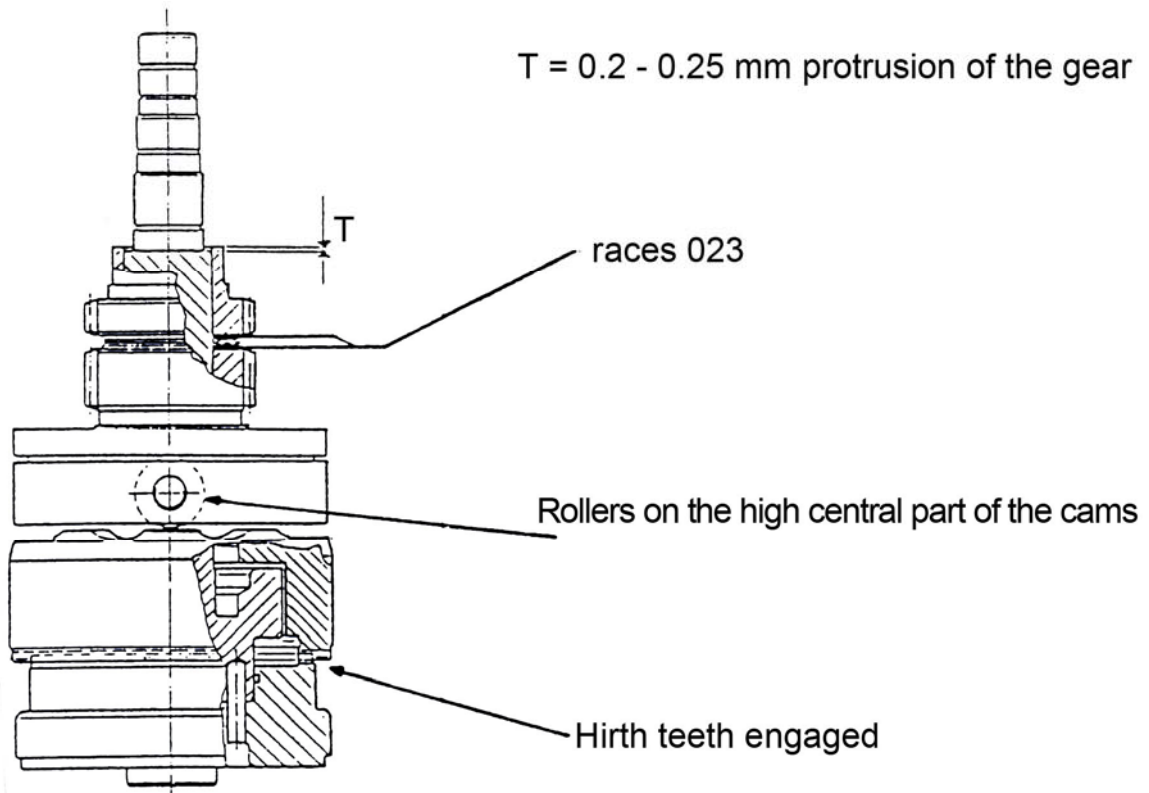

-Assemble the parts as shown, and then check that the value of U is between the ranges in the table below. If it is not then grind a new distance piece 025 to it so that U falls within the ranges specified in the table.

Turret Size	Dimension U (mm)
AK3163	1.8
AK3180	2.1
AK31100	1.7
AK31125	2
AK31160	3
AK31200	4

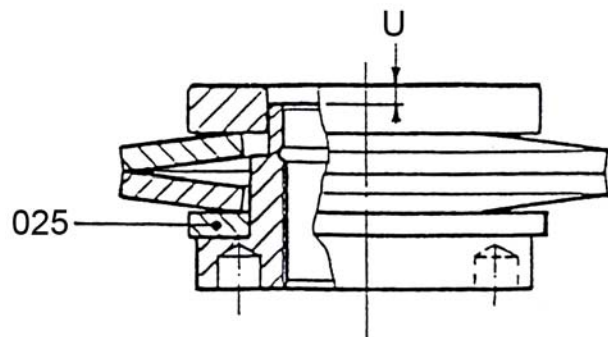

DURING COMPLETE REASSEMBLY

- Insert the keys 30° into their corresponding keyways (with identical marks) keeping the threaded hole turned towards the ring nut 020 and in contact with the bottoms of the keyways.
- Check that pinion 008 has a good sliding fit. If it does not, take it off and assemble it the other way with respect to the keys.
- Check that the ring nut is thoroughly tightened. To make sure of this follow these instructions :
 - Before final assembly temporarily set aside parts # 026 ,307,025, screw down the ring nut till it touches its seating, measure the distance between the end of the divider 005 and the top surface of the ring nut, mark the position of the ring nut in respect to the divider .

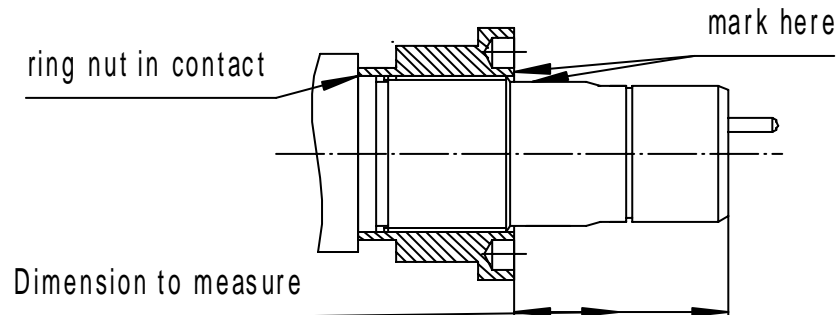

Then unscrew the ring nut, assemble the parts # 026 ,307,025,screw on the ring nut ,check that it reaches the same position as before .Make this check by measuring the distance and observing that the marks coincide .Before inserting the central subassembly into the carcass ,rotate the satellite carrier 007 until the seating of the latch is in perpendicular position towards the coolant interception holes of the crown 002 ;insert the catch 017 ,rotate the satellite carrier 007 by hand until the Hirth teeth engage (rollers on the level parts of the cams) .

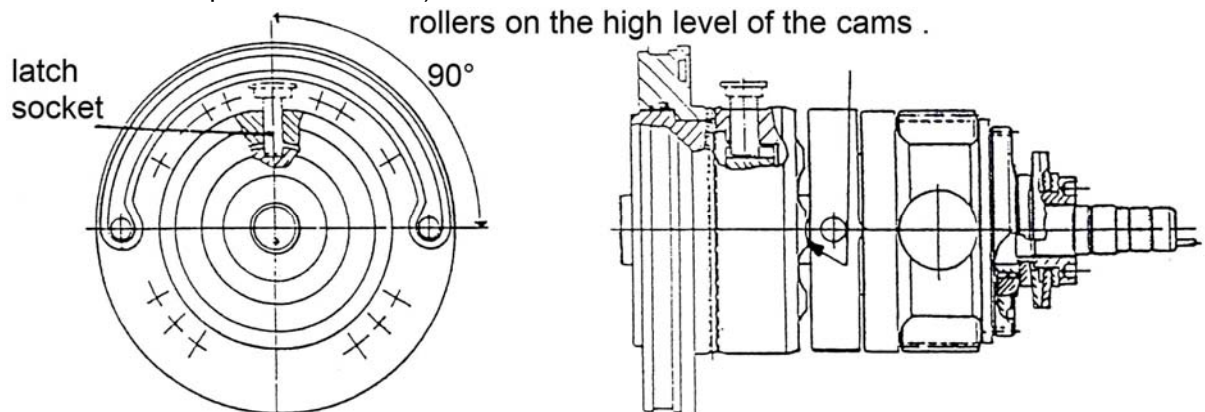

Assemble the plungers 018 with the “y” ends turned upwards. After assembling all the parts add right amount of the correct type of lubricant to the carcass through the oil hole (see sheet 19).

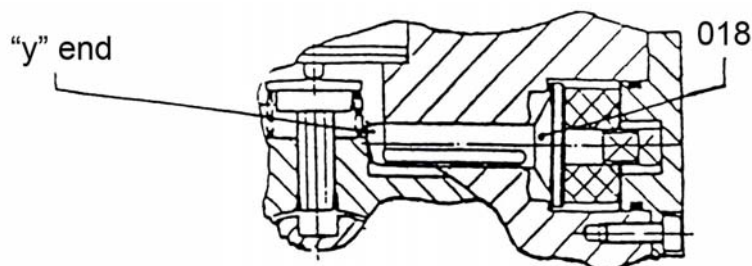

Lubricate o-ring 318 with heavy grease or vaseline

The mechanical moving parts of the turret are permanently lubricated.
 The lubricant must be renewed only after eventual complete dismantling of the turret.
 The lubricant, with viscosity 80 SW 90, must be compatible with rubber & Teflon.
 The following table indicates the quantities to be used.

TURRET SIZE	QUANTITY OF OIL (kg)
AK3163	0.3
AK3180	0.7
AK31100	1.5
AK31125	2
AK31160	4
AK31200	4

SUBSTITUTION OF THE COOLANT BUSHING

Take off the airtight plug or the feeding pipe connector of the coolant ,take off the spiral spring; then extract the bush 033 complete of O-Ring 322 by using a suitable thread X .

Clean the seating from any eventual incrustation, grease the outside part of the new bushes complete of O-Ring, then insert them in their seating and check the sliding.

Turret type	X
AK3163	M8X5
AK3180	M8X8
AK31100	M10X8
AK31125	M12X8
AK31160	M16X8
AK31200	M16X8

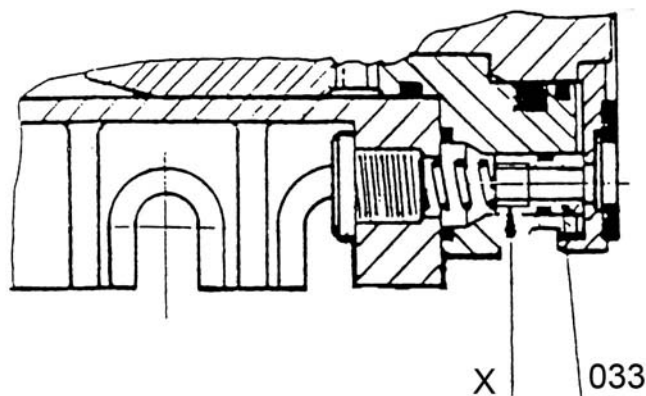

Remove the rear cover 011; extract the terminal block support 045 complete with terminal block 310. Disconnect the leads connecting terminal block to the motor, the brake, and the terminal probes (head sensors). Unscrew screw 311, extract the motor until 150. Disassemble the gear 015 and remount it on the new motor unit. Mount the motor unit in the carcass and reconnect the electric wiring to the terminal block. To check that the phases are connected properly, perform a tool change by calling up the nearest stationif the phases are properly connected the change of station will take place by the shortest route, if the disc goes the long way round then interchange two motor supply wires at the terminal block (phase rotation) Replace the rear cover .

SUBSTITUTION OF THE PREINDEXING ELECTROMAGNET

Remove the top cover 044, remove support 042, remove the washers 046a, extract the electromagnet 200.

Remove the rear cover 011 and disconnect the electromagnet supply leads.

Mount the new electromagnet in the carcass and fix it down with the two washers. Replace the support complete with its proximity switch 301 and reset it (see sheet 23). Connect the electromagnet lead wires to the terminal block (see electrical connection schemes, sheet 9); replace top & rear covers.

SUBSTITUTION OF THE BRAKE MAGNET AND ADJUSTMENT OF THE AIR GAP

Remove the rear cover 011, demount the motor unit 150, and the gear 015. Disconnect the brake leads. Remove the defective brake magnet and substitute it with the new one. Adjust the air gap (0.2-0.3mm to be checked in a vertical position and acting on the distance pieces 090) Reassemble the whole by following the above sequence in reverse .

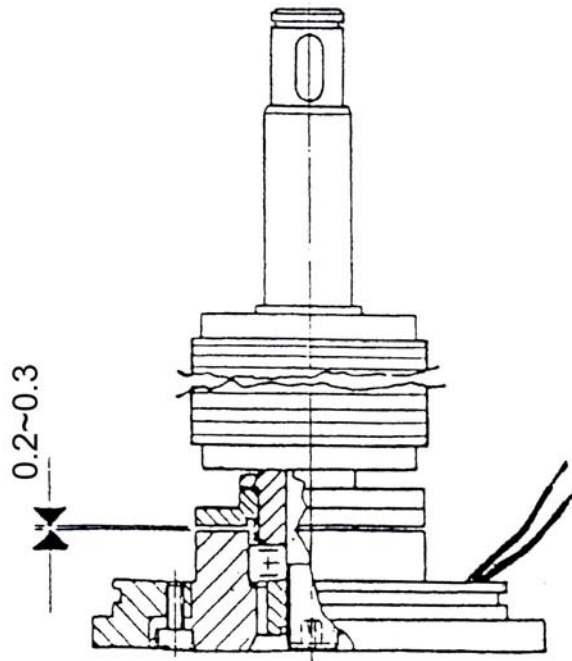

Remove the rear cover 011, disconnect the encoder leads from the terminal block 310, remove the stirrups 067 and extract the encoder. Remove the driving hub 035 and mount it on the new encoder. Remount the encoder following the above instructions in reverse and connect it to the terminal block. Before finally fixing the encoder set it as follows :

-Lock the turret in any position, rotate the encoder slowly until the STROBE signal disappears (this can be checked on the control system or with a voltmeter). Mark the encoder and make a corresponding mark on its support. Slowly turn the encoder in opposite direction until the strobe signal again disappears, and mark the new position on the support. This defines the region in which there is a strobe signal. Slowly turn the encoder until the mark on the shaft is half way between the two marks on the support. Tighten the stirrups 067 and replace the rear cover.

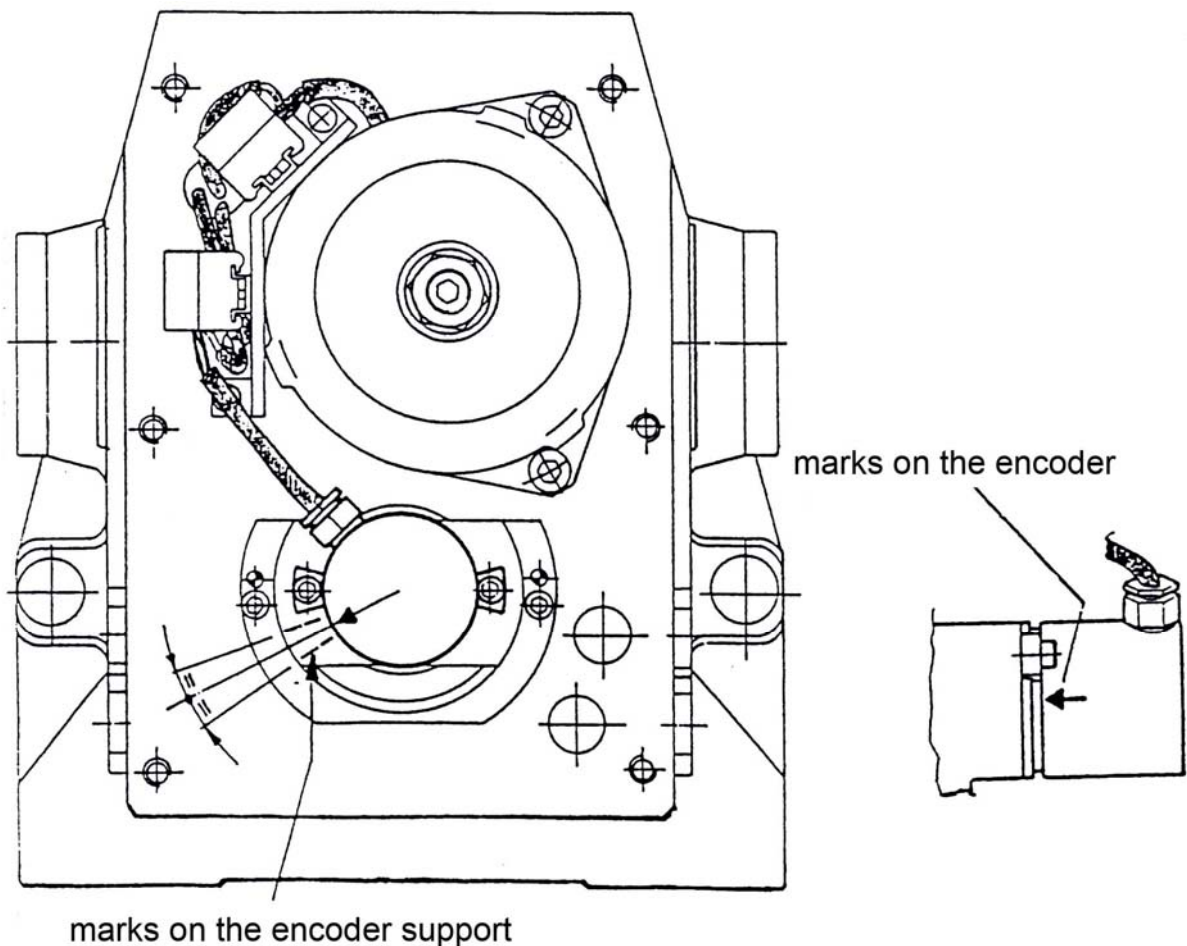

SUBSTITUTION AND SETTING OF THE PREINDEXING PROXIMITY SWITCH

SHEET 23

Remove the top cover 044, remove the support 042 together with the proximity switch 301. Remove the rear cover 011, disconnect the proximity switch leads from the terminal block 310 and remove the proximity switch. Screw the new proximity switch into the support until it projects by the correct amount "X". Assemble the support fixing it with the screw 300a in such a way that the LED (light emitting diode) luminous indicator on the end of the proximity switch is visible. Insert a 0.8 mm thickness gauge (see figure) and bring the proximity switch into contact with the thickness gauge using a spanner (diam.7 mm) on the hexagon on the end of the proximity switch .Tighten the screw 300-300a with a torque of 3 Nm and block them with lactate. Connect the leads to the terminal block, and check that the proximity switch operates correctly when live, as follows:

-with the turret closed (locked)on lowering the and of the electromagnet by an amount between 1.8 and 2.5 mm the luminous red indicator on the back part of the proximity switch should light up. Replace the rear cover and the top cover.

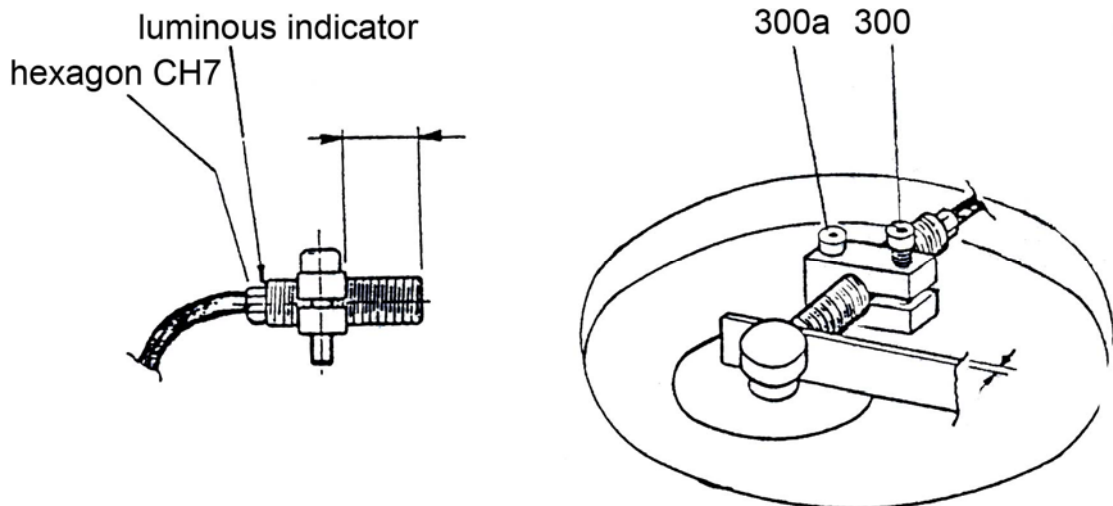

Turret size	distance X mm
AK3163	18.3
AK3180	18.3
AK31100	18.3
AK31125	18.3
AK31160	18.3
AK31200	18.3

Remove the top cover 044, unscrew screw 314, extract and support 049, take off the rear cover 011, disconnect the leads of proximity switch 313 from the terminal block. Using a screw driver as lever lift the peened edge of the ring nut 048 and unscrew the ring nut. Unscrew and remove the wire clip 058 and remove the proximity switch. Screw the new proximity switch into the support by amount needed to make dimension Z equal to figures in the table below. The dimension given for Z in the table is however only indicative and correct setting of the operating distance P may require departure from those values. The amount of the operating distance is obtained by difference:

$$(P)0.8=V-Z$$

where V and Z are actual measured values. To measure V the closing sector (i) of the roller ring 006 must be against the proximity switch that is to say with the turret in the locked condition. If it is not in this state the carry out the closing operation manually (see sheet 24). After adjusting the value of the operating distance P screw down the ring nut (tightening torque 3 Nm). Peen over the edges of the ring nut, thread the wire clip 058 on the proximity switch leads. Replace and screw on the support 049. Connect the proximity switch leads to the terminal block (see wiring scheme). With the proximity switch live the red luminous indicator on the end of the proximity switch should be visible through the upper hole (r) in the support 049. When this indicator is lit turret is in the locked condition. Refix the clip, the rear cover and the top cover.

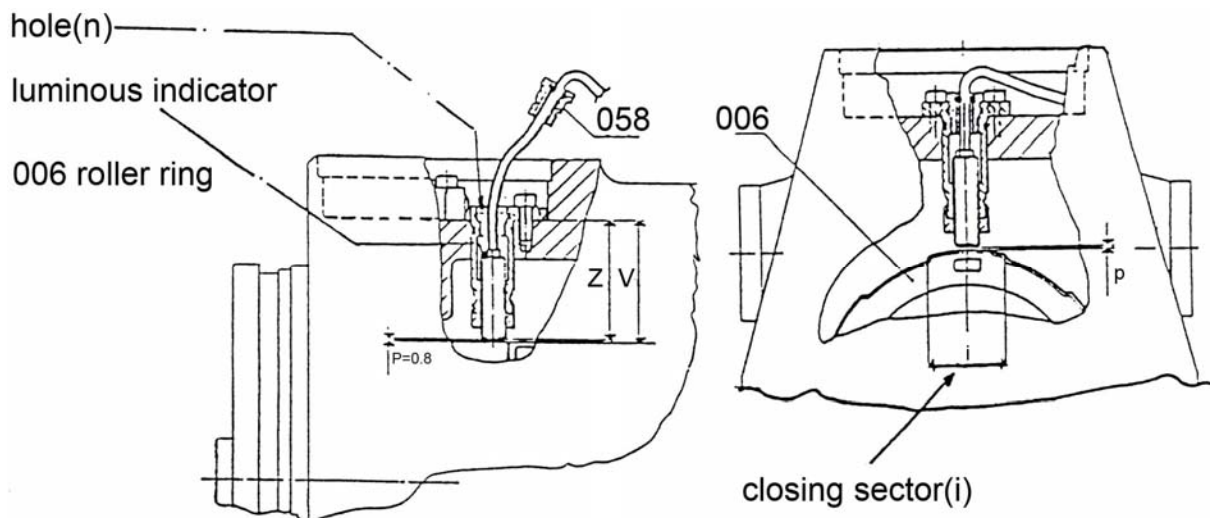

Turret size	Indicative value of Z mm
AK3163	60.7
AK3180	59.7
AK31100	60.7
AK31125	75.7
AK31160	66.7
AK31200	99.2

**OPERATIONS TO BE CARRIED OUT IN CASE THE
POSITIONING CYCLE HAS NOT BEEN COMPLETED**
(because of an emergency or accidental stop)

SHEET 25

Call up from the console a “tool change” (the nearest one) keeping to the same direction of rotation that the turret(the toolholder disc) had when it stopped. If this is not known and the “change” called for does not go through to completion (namely not locking or bringing about the operation of the heat sensors), proceed as follows:

----Noted the direction of the disc rotated during the attempted (unsuccessfully) “tool change”; call up from the console the nearest station which can be reached by rotating the disc from its present position in the opposite direction to that of the previous attempt.

If the control refuses to accept a “tool change “starting from the condition of “turret unlocked”, then carry out the necessary operations manually as follows:

---Remove the rear cover 011 and the top cover 044, unscrew and partially extract the wire clip 058, disconnected the motor and the brake leads from terminal block (still keeping the proximity switches connected; please note the order of the motor wires, in order to avoid wrong connection at the end of operations), using a hexagonal spanner (see table)turn the motor shaft 012 by hand so that the toolholder disc rotates in the same direction as it did when it stopped and at the same time push the core 073 of the electromagnet of motor shaft until the red indicator of proximity switch 313 light up and can be seen from above through the hole (n). Make the shaft rotate for another turn but working so that the indicator still remains lit. If direction in which the disc was rotating when it stopped is not known and a mechanical block is encountered after the reversal and the turret will not lock, the shaft must be made to rotate in the same sense as that proceeding the reversal. Screw on the wire clip, reconnect the leads to the terminal block (care the phases of motor leads) replace top & rear covers.

Turret size	Size of spanner CH mm
AK3163	5
AK3180	5
AK31100	5
AK31125	5
AK31160	6
AK31200	6

After about 400.000 operations:

---Check that the core 073 of the electromagnet 200 slides freely, by pushing its end several times and letting it be returned by the spring 047. Then turn it round several times. Clean off any foreign bodied from the core and nearby parts, and put a film of oil on the outer surface of the core where it enters the electromagnet.

---Check the wear on the bushing 033 which transfers the liquid coolant 033 and change it if necessary.

---Check the seals 315 and 308. It is essential to substitute them if there is any sign of deterioration or wear.

---To check the above seals: unscrew the screws 331, extract the pins 332, and take out the rotating crown 003. If an appreciable quantity of oil comes out the seals should be substituted.

NAME	REFERENCE
Pads (2 off)	032
Fluid coolant valve	033
Motor unit	150
Encoder unit	160
Brake magnet	175
Electromagnet	200
Preindexing proximity switch	301
Wiping seal	308
Locking proximity switch	313
O ring	315
O ring	316
O ring	317
O ring	318
O ring	319
O ring	320
O ring	321
O ring	322
O ring	323
O ring	324
O ring	325
O ring	326
O ring	327
O ring	328
O ring	329

When ordering please quote type, size, series and batch numbers as on the identification plate.

TABLE OF DATA

SHEET 28

ITEM	TURRET SIZE							
	AK3163		AK3180			AK31100		
Code number of transmission ratio	8	12	8	10	12	8	12	
Moment of inertia of transportable masses (kgm)	0.65	0.50	1.3	0.8	0.5	4.5	3.0	
Tangential couple applicable with turret locked (Nm)	800		1850			3500		
Unbalance couple with horizontal axis (Nm)	10		15			40		
Repetition accuracy (grad)	±2"		±2"			±2"		
Turret weight without disc (Kg)	50		58			103		
N.of movements per hour	750		750			750		
ITEM	TURRET SIZE							
	AK31125		AK31160			AK31200		
Code number of transmission ratio	8	12	8	10	12	8	10	12
Moment of inertia of transportable Masses (kgm)	7.5	4.5	32	22	15	70	32	22
Tangential couple applicable with turret locked (Nm)	6900		16000			26000		
Unbalance couple with horizontal axis (Nm)	60		160			470		
Repetition accuracy (grad)	±2"		±2"			±2"		
Turret weight without disc (Kg)	135		380			480		
N.of movements per hour	750		600			600		

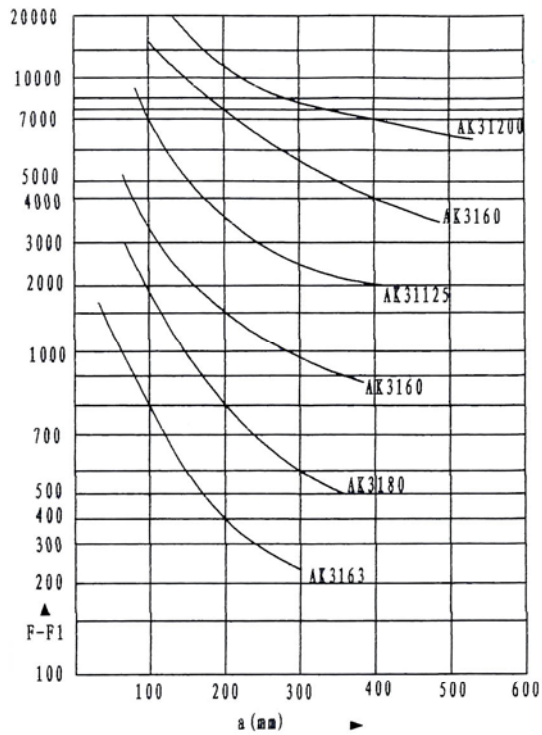

As a function of the tangential thrust $F_e F_1$

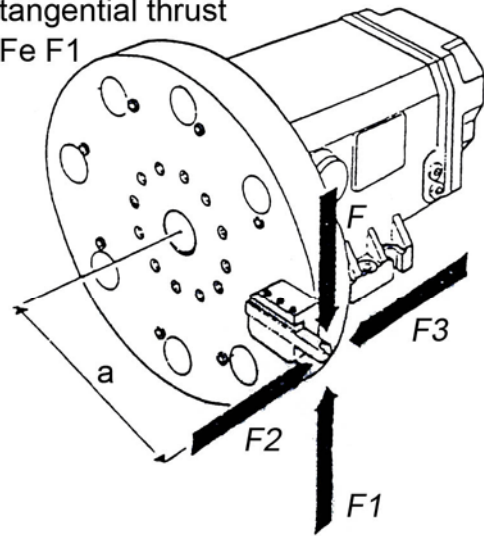

As a function of the pressing axial force F_2 and of the lifting axial force F_3

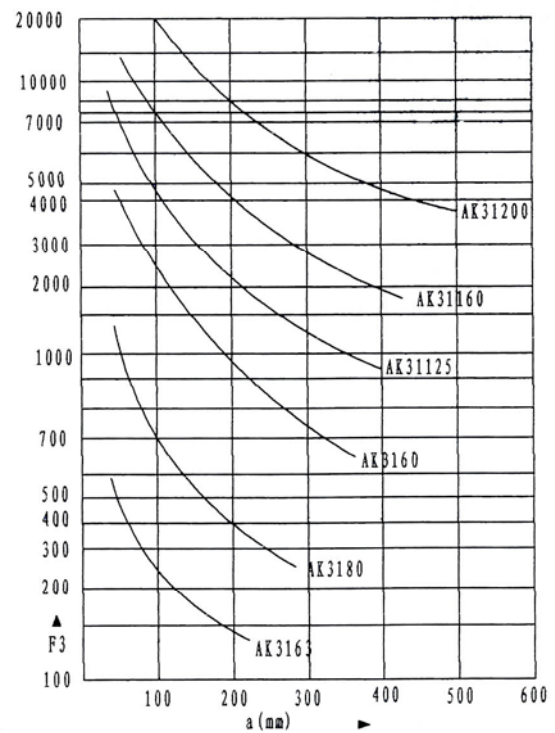
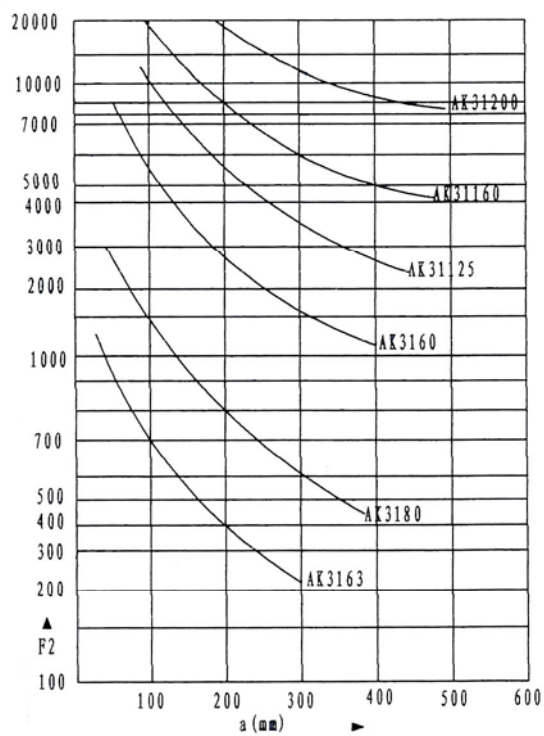

After having selected the size of turret according to the above criteria, check that the moment of inertia to be applied is below the maximum values given in the Table of Technical Data

PROBLEMS	CAUSE	REMEDY
Turret does not start	No power at motor	Get power to the motor
	Motor defective	Substitute the motor until (see sheet 20)
	Heat sensor in operation	See next point
Turret does not complete its indexing cycle either because the heat sensor operates or an incomplete cycle is indicated	Number of movement/hour above the maximum permissible	Reduce the number of movements (see technical data sheet 27)
	With the turret free in the position required and with current supplied to the motor there is no signal from the preindexing proximity sw.301	Substitute the preindexing proximity sw.(see sheet 22)
	preindexing proximity sw.in defective	
	preindexing proximity sw. not correctly set	Adjust the preindexing proximity switch (see sheet 22)
	With the turret in the required position and with current supplied to the motor there is no signal from the locking proximity sw.313	Substitute the locking proximity sw.(see sheet 23)
	Locking proximity is defective	
	Locking proximity switch out of adjustment	Adjust the locking proximity switch (see sheet 23)

PROBLEMS	CAUSE	REMEDY
	Restart after an emergency or accidental stop, but in opposite direction to that most convenient	See sheet 24
	Blockage of the electromagnet's core	See sheet 25
The turret overruns the preindexing station required	Electromagnet excited late	Overhaul the control apparatus
Turret does not stay locked	Delay in switching off the motor and in the braking	Overhaul the control apparatus
	Brake defective	Substitute the brake magnet (see sheet 20)
	Brake wear excessive	Readjust the air gap in the brake (see sheet 20)
The turret continues rotate without stopping at the required station	Angular encoder defective	Substitute the angular encoder (see sheet 21)
	Electromagnet defective	Substitute the electromagnet(see sheet 20)
	Power does not reach electromagnet or voltage is below that specified	Bring power supply up to specified value.
	Break in the electrical leads	Eliminate the interruption.

PROBLEMS	CAUSE	REMEDY
The turret approaches the required station by the longer path	Inverted phases in the power supply of the motor	Correct the connection of the phases
Excessive shock in preindexing	Excessive travel of the buffer pads	Substitute the buffer pads
	Moment of inertia of masses in use is above the permissible maximum	Bring the moment of inertia of the masses in use down to a permissible figure (see sheet 27)
	Moment of unbalance of masses in use is above the permissible maximum	Bring the moment of unbalance of the masses in use down to a permissible figure (see sheet 27)
Disc rotates in jerks	Moment of unbalance above the permitted	Bring the moment of unbalance of the masses in use down to a permissible figure (see sheet 27)