

The Seakeeper 35 is designed to achieve 70 to 90% roll reduction on boats up to 140 tons. Multiple units can be fitted for larger boats. The Seakeeper 35 requires only modest electrical power, has no outside appendages, and can be installed off centerline, if necessary. Its computerized control and vacuum technology make it the first truly practical, and only modern, anti-roll gyro.



SPECIFICATIONS

Rated Speed	5,150 RPM
Angular Momentum at Rated RPM	35,000 N-M-S
Anti-Rolling Torque at Rated RPM	73,000 N-M
Spool-up Time to Rated RPM	65 minutes (5,150 RPM)
Spool-up Time to Stabilization	45 minutes (4,380 RPM)
Spool-up Power	
AC Motor:	5000 Watts Max
DC Control:	240 Watts
Operating Power	
AC Motor (sea state dependent):	2000-5000 Watts
DC Control:	240 Watts
AC Input Voltage:	208-230 VAC (+/- 10%), 50/60 Hz, Single Phase
DC Input Voltage:	24 VDC @ 10 Amps
Sea Water Supply to Heat Exchanger	53 LPM (14 GPM) maximum 38 LPM (10 GPM) minimum
Ambient Air Temperature	0°-60° C (32°-140° F)
Weight	1778 kg (3920 lbs) bolt-in installation
Envelope Dimensions	Length x Width x Height 1.38 L x 1.42 W x 1.11 H (meters) 54.3 L x 55.9 W x 43.5 H (inches)
Noise Output	Steady state noise measured in the factory at a 1 meter distance measures 72-74 dBC.

PORT VIEW

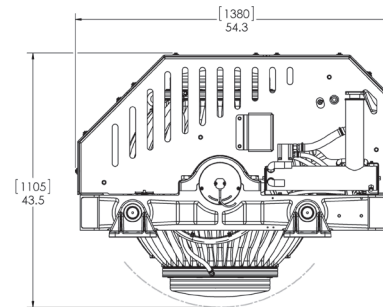

FRONT VIEW

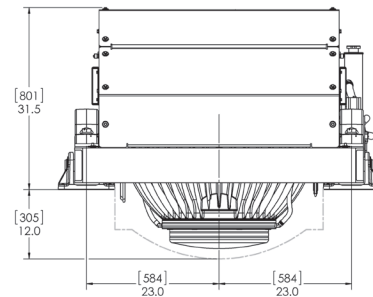

TOP VIEW

