

# ZOOK®

## ONE source for ALL your Rupture Disk needs...

- Holders
- Gaskets
- Burst Sensors
- Alarm Monitoring Systems
- Transportation Disks
- Sanitary Disks
- Explosion Vent Panels
- Extruder Barrels
- Special Applications

Service Personnel  
are available...







**24** hrs/day

**7** days/wk

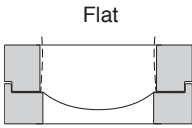
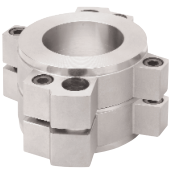

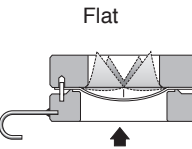

**365** days/yr



# Reverse Acting (Compression-Loaded) Metal Rupture Disks

Disk Series	Sizes in./mm	Pressures psig/ bar	Standard Operating Ratio <sup>1</sup>	Vacuum Support Required	UD ASME COMPLIANT	Seat Configuration Flow Direction	Standard Mating Holder
<b>RA4</b>  Solid metal, non-fragmenting design disk	1 – 12 25 – 300	2 – 40 0.14 – 2.76	90%	NO	Liquid and Gas	 Flat 	<b>RAH</b>
<b>RA6</b>  Solid metal, non-fragmenting design disk	1 – 12 25 – 300	12 – 200 0.83 – 13.79	90% <sup>2</sup>	NO	Liquid and Gas		
<b>RA8</b>  Solid metal, non-fragmenting design disk	1 – 12 25 – 300	26 – 1,000 1.79 – 68.97	90% <sup>2</sup>	NO	Liquid and Gas		
<b>RAX</b>  Solid scored metal, non-fragmenting design disk	1 – 12 25 – 300	27 – 1,000 1.86 – 68.97	90% <sup>2</sup>	NO	Gas only		Pre-torque design
<b>SRA</b>  Solid scored metal, non-fragmenting design disk	1 – 20 25 – 500	20 – 1,000 1.38 – 69	90%	NO	Gas only	 Flat 	<b>SR7A</b>

## Sanitary Rupture Disks

Disk Series	Sizes in./mm	Pressures psig/ bar	Standard Operating Ratio <sup>1</sup>	Vacuum Support Required	UD ASME COMPLIANT	Features	Disk Mounting Flow Direction Standard sanitary fittings
<b>SD</b>  Graphite rupture disk	1 – 4 25 – 100	1.5 – 50 0.10 – 3.45	90%	Contact ZOOK on pressures less than 25 psig	Liquid and Gas	<ul style="list-style-type: none"> <li>• FEP liner on process side</li> <li>• Mounts using standard sanitary style O-Ring gasket</li> </ul>	
<b>RLPS</b>  Solid metal, non-fragmenting design disk	1 – 4 25 – 100	4 – 83 0.27 – 5.72	90% <sup>2</sup>	NO	NO	<ul style="list-style-type: none"> <li>• Standard black Buna-N gasket supplied with disk</li> </ul>	
<b>RAUS</b>  Solid metal, non-fragmenting design disk	1 – 4 25 – 100	18 – 300 1.24 – 20.69	90% <sup>2</sup>	NO	Liquid and Gas	<ul style="list-style-type: none"> <li>• Standard black Buna-N gasket supplied with disk</li> </ul>	

<sup>1</sup> Standard operating ratio applies to the marked rating on the disk tag on disks marked above 40 psig.

Contact ZOOK for operating ratio on disks marked below 40 psig.











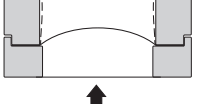
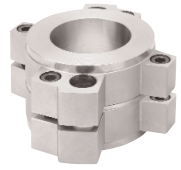
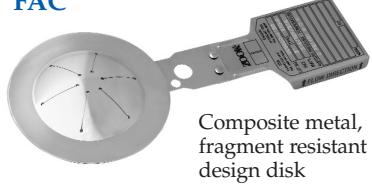

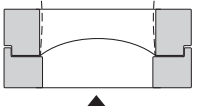
<sup>2</sup> Higher operating ratio may be available upon request.

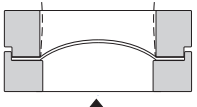

# ZOOK®

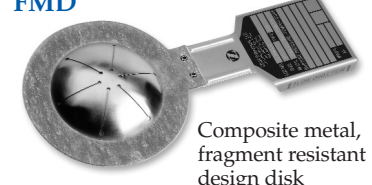
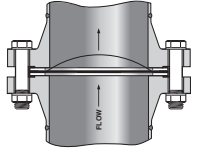
Service Personnel are available 24.7.365  
To reduce Your Plant Downtime  
when an emergency occurs...  
call **800.543.1043**

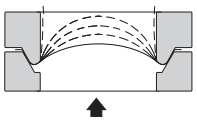
# Forward Acting (Tension-Loaded) Metal Rupture Disks

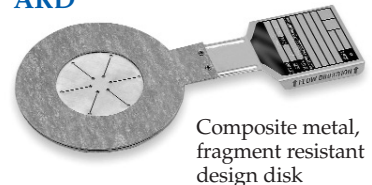
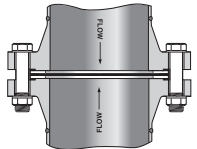
Disk Series	Sizes in./mm	Pressures psig/bar	Standard Operating Ratio <sup>1</sup>	Vacuum Support Required	UD ASME COMPLIANT	Seat Configuration Flow Direction	Standard Mating Holder
<b>FAX</b>  Solid metal scored, non-fragmenting design disk	1 – 12 25 – 300	45 – 1,500 3.10 – 103	85% <sup>2</sup>	Contact ZOOK	Gas only	Flat 	<b>FAH</b> 
<b>FAC</b>  Composite metal, fragment resistant design disk	1 – 12 25 – 300	3 – 1,500 0.21 – 103	80%	YES	Contact ZOOK		Pre-torque design
<b>SFAZ</b>  Solid metal scored, non-fragmenting design disk	1/2 – 24 13 – 600	15 – 60,000 1.03 – 4138	85% <sup>2</sup>	Contact ZOOK	Gas only	Flat 	<b>UHZ</b>  Bolted type insert design
<b>D</b>  Composite metal, fragment resistant design disk	1/2 – 24 13 – 600	3 – 2,000 0.21 – 138	80%	YES	Liquid and Gas	30° Angular 	<b>7A</b>  Bolted type insert design
<b>FD/FDZ</b>  Composite metal, fragment resistant design disk	11/16 – 44 17 – 1117	3 – 2,000 0.21 – 138	80%	YES	NO	Flat 	<b>UH/UHZ</b>  Bolted type insert design
<b>FMD</b>  Composite metal, fragment resistant design disk	2 – 36 50 – 900	1 – 1440 0.07 – 99.3	80%	YES	NO	Flat 	Mounts between standard companion flanges – no holder required
<b>PB</b>  Solid metal, fragmenting design disk	1/4 – 24 6 – 600	3 – 50,000 0.21 – 3448	70% <sup>2</sup>	YES	Liquid and Gas	30° Angular 	<b>7A</b>  Bolted type insert design
<b>ARD</b>  Composite metal, fragment resistant design disk	2 – 44 50 – 1117	1 – 60 0.07 – 4	50%	YES	NO	Flat 	Mounts between standard companion flanges – no holder required

<sup>1</sup> Standard operating ratio applies to the marked rating on the disk tag on disks marked above 40 psig.

Contact ZOOK for operating ratio on disks marked below 40 psig.

<sup>2</sup> Higher operating ratio may be available upon request.



## Accessory Kit

...used to monitor the air gap between a rupture disk and relief valve or the presence of backpressure in a header system

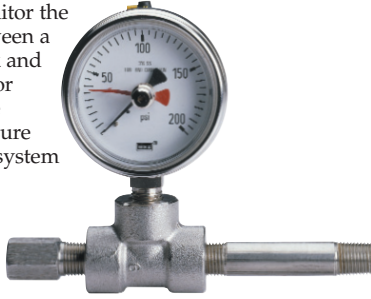

## Explosion Vent Panels

...provide over-pressure relief to minimize structural or mechanical damage caused by expanding gases



## Pipe End Covers

### Applications

Protection of Safety Relief Valves, Rupture Disks, Manifold piping systems, Ductwork, Common header systems, Flame stacks, Storage tanks

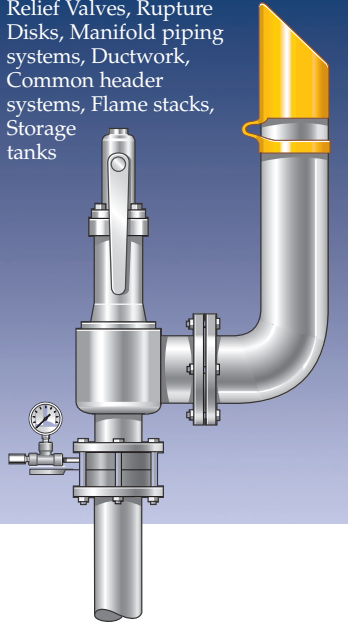

The products shown in this bulletin will improve your operating efficiency, protect equipment and personnel from the effects of overpressurization in static and dynamic pressurized systems, and are immediately available.

## Extruder Barrels

...designed for over-pressure protection of plastic extrusion processes



## Union and Screw Type Disk Holders

...reusable units for use on high pressure equipment, gas cylinders, laboratory equipment, autoclaves. Contact ZOOK for information concerning your application.

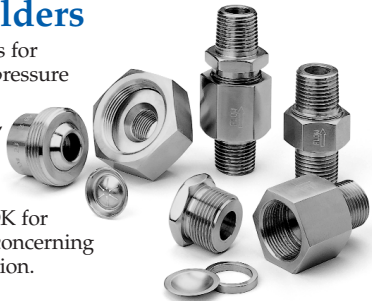

Credits  
Viton – TM DuPont  
TD, SD – TM ZOOK Enterprises, LLC



**ZOOK Enterprises, LLC**  
16809 Park Circle Drive  
Chagrin Falls, OH 44022 U.S.A.  
Toll Free **800.543.1043**  
Phone **440.543.1010**  
Fax **440.543.4930**  
E-mail **sales@zook.cc**









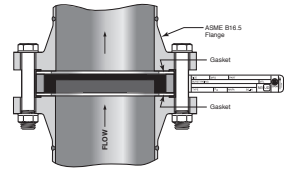

**ZOOK Canada, Inc.**  
4400 South Service Road  
Burlington, ON Can. L7L 5R8  
Toll Free **800.370.6057**  
Phone **905.681.2885**  
Fax **905.681.8838**  
E-mail **sales.canada@zook.cc**

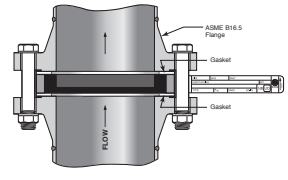
**ZOOK Europe, LTD.**  
Navigation House, Bridge Street  
Killamarsh, Sheffield UK. S21 1AL  
Phone **0044 (0) 1909 560999**  
Fax **0044 (0) 1909 560860**  
E-mail **zookeurope@zook.cc**

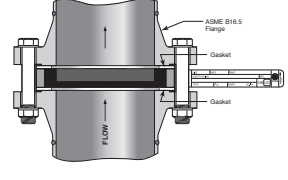

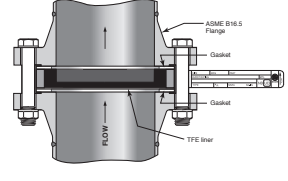
visit us on the web at [www.zook.cc](http://www.zook.cc)

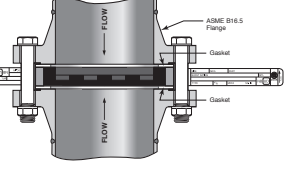
# Graphite Rupture Disks

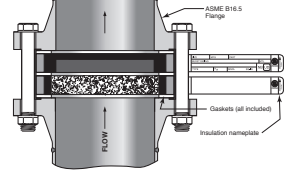
Disk Series	Sizes in. / mm	Pressures psig / bar	Maximum Operating Ratio <sup>1</sup>	Vacuum Support Required	UD ASME COMPLIANT	Mounts directly between standard ASME B16.5 Class, DIN, or JIS flanges <b>Flow Direction</b>
<b>MONO</b>  ...best choice for low and intermediate burst ratings	1/2 – 24 13 – 600	0.25 – 1,000 0.02 – 69	90%	Yes on pressures less than 25 psig	Liquid and Gas	
<b>INVERTED</b>  ...best choice for higher burst ratings	1/2 – 24 13 – 600	0.25 – 1,000 0.02 – 69	90%	Contact ZOOK on pressures less than 25 psig	Liquid and Gas	
<b>FS-INVERTED</b>  ...best choice for highly corrosive and broad temperature range applications	1/2 – 24 13 – 600	1.00 – 1,000 0.07 – 69	90%	Contact ZOOK on pressures less than 25 psig	Liquid and Gas	
<b>DUPLEX</b>  ...best choice for highly corrosive applications	1/2 – 24 13 – 600	0.25 – 1,000 0.02 – 69	90%	Contact ZOOK on pressures less than 25 psig	Liquid and Gas	
<b>TWO-WAY</b>  ...dual rated to protect against two different pressures in opposite directions	1-1/2 – 24 40 – 600	0.25 – 1,000 0.02 – 69	90%	N/A	NO	
<b>INSULATED UNIT</b>  ...for temperatures exceeding 430°F (221°C) to 700°F (371°C)	1 – 24 25 – 600	0.25 – 1,000 0.02 – 69	90%	Contact ZOOK on pressures less than 25 psig	NO	

<sup>1</sup> Standard operating ratio applies to the marked rating on the disk tag on disks marked above 40 psig.

Contact ZOOK for operating ratio on disks marked below 40 psig.

<sup>2</sup> Higher operating ratio may be available upon request.

## Burst Sensors *Suitable for use in hazardous locations*

### Re-usable



Model BA  
Metal & Graphite

...fits easily into existing pipe systems

### One time use

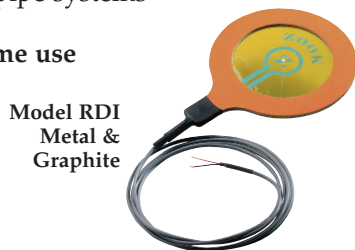

Model RDI  
Metal & Graphite

### Integral Indicators

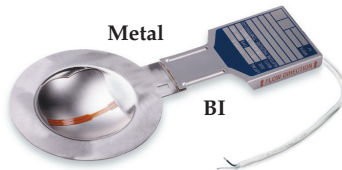

Metal  
BI

### Graphite



ZENSOR®

...ideal for a wide range of applications

### Alarm Monitoring System









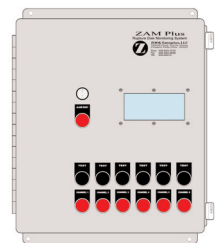

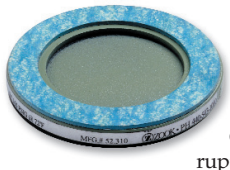

LD

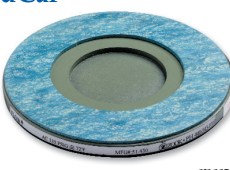
...optional leak detection device for BA and RDI Burst Sensors

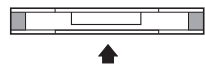
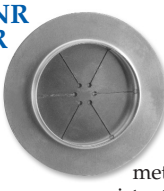

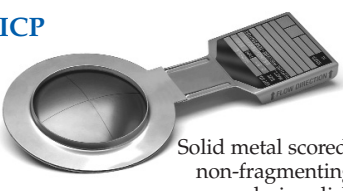

...ZAM Plus alarm monitor is designed to remotely detect the condition of up to eight rupture disks in service

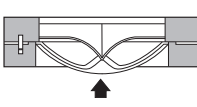

# Transportation Rupture Disks

Disk Series	Sizes in.	Standard Pressures psig @ 72°F	Standard Operating Ratio <sup>1</sup>		Vacuum Support Required	UD ASME COMPLIANT	Features	Disk Mounting Flow Direction
			positive	negative				
<b>RailCar</b>  Graphite rupture disk	2	60, 100, 165	90%		NO	NO	<ul style="list-style-type: none"> <li>• PTFE &amp; Viton liner on process side</li> <li>• Carbon Steel Armor</li> <li>• TFE coated green</li> <li>• Non-Asbestos gasket on vent side</li> </ul>	2" AAR metal seated safety vents 
<b>AcidCar</b>  Graphite rupture disk	2	60, 100, 165	90%		NO	NO	<ul style="list-style-type: none"> <li>• PTFE &amp; Viton liner on process side</li> <li>• Carbon Steel Armor</li> <li>• TFE coated green</li> <li>• Non-Asbestos gasket on vent side</li> </ul>	2" AAR rubber covered safety vents 
<b>TD</b>  Graphite rupture disk	2,3, 4	30, 35, 40, 45, 50	90%		NO	YES	<ul style="list-style-type: none"> <li>• PTFE liner on process side</li> <li>• Carbon Steel Armor</li> <li>• TFE gasket on pressure side</li> <li>• Non-Asbestos gasket on vent side</li> <li>• TFE coated green</li> </ul>	Standard ASME B16.5 Class 150 flanges 
<b>TCP-NR TCP-R</b>  Composite metal, fragment resistant design disk	2	75, 100, 165	50%		NO	NO	<ul style="list-style-type: none"> <li>• 316SS construction w/PFA seal</li> </ul>	Fits standard tank car safety vents  <b>TCP-NR</b> Fits standard tank car safety vents  <b>TCP-R</b>
<b>TCP-S</b>  Solid metal scored, non-fragmenting design disk	2	75, 100, 165	85%		NO	NO	<ul style="list-style-type: none"> <li>• 316SS construction w/PFA seal</li> <li>• 316SS locating ring on vent side</li> </ul>	Fits standard tank car safety vents 
<b>ICP</b>  Solid metal scored, non-fragmenting design disk	2-1/2 & 3	54.4, 63.8 (68°F & 140°F)	85%		NO	NO	<ul style="list-style-type: none"> <li>• Nickel disk construction</li> <li>• PTFE gasket &amp; PFA liner on process side</li> <li>• 316SS locating ring on vent side</li> </ul>	Standard ASME B16.5 Class 150 & ISO flanges 

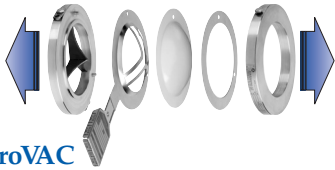
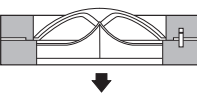
# Ultra-Low Pressure Rupture Disks

Disk Series	Sizes in./mm	Pressures		Standard Operating Ratio <sup>1</sup>		UD ASME COMPLIANT	Seat Configuration Flow Direction	Standard Mating Holder
		positive	negative	positive	negative			
 <b>ProPOS</b> Dual-acting, tension loaded, design disk	2 – 14 50 – 350	1" of water column to 30"	2 psig to 150 psig	-0- w/TFE girdle 20% w/316SS girdle	80%	NO	Flat 	
 <b>ProVAC</b> Dual-acting, tension loaded, design disk	2 – 14 50 – 350	2 psig to 150 psig	1" of water column to 30"	80%	-0- w/TFE girdle 20% w/316SS girdle	NO	Flat 	

<sup>1</sup> Standard operating ratio applies to the marked rating on the disk tag on disks marked above 40 psig. Contact ZOOK for operating ratio on disks marked below 40 psig.