

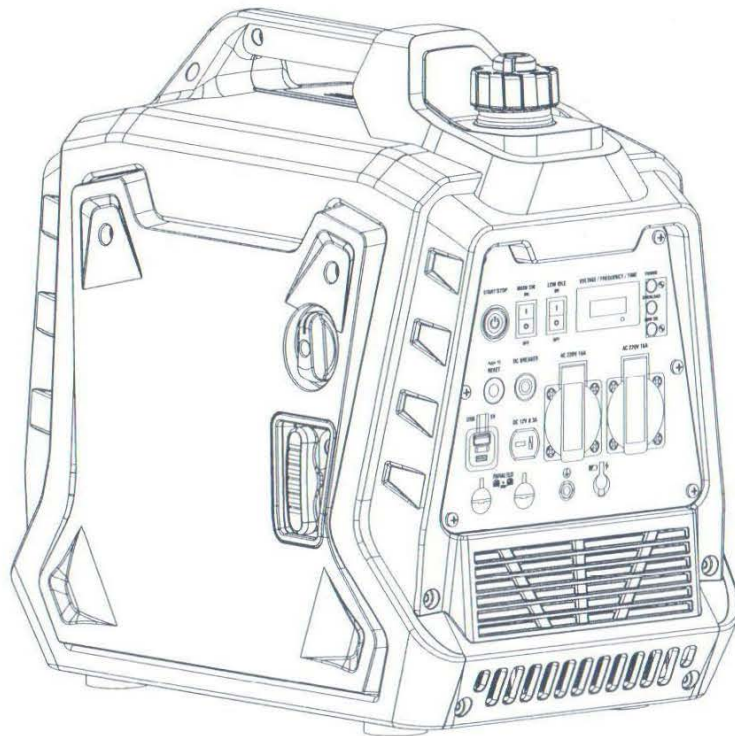

## INVERTER GENERATOR User's Manual



**WARNING: SAVE THIS MANUAL FOR FUTURE REFERENCE**

This manual contains important information regarding safety. Operation, maintenance and storage of this product. Before use, read carefully and understand all cautions, warnings, instructions and product labels. Failure to do so could result in serious personal injury and/or property damage.

---

Thank you very much for choosing generator set product manufactured by our Company!  
This Manual will instruct you how to operate and use the generator set safely and properly.  
Please be sure to read it carefully before using.

All technical data and diagrammatic presentations in this User's Manual are consistent with the latest product at the time of publication.

Due to the revision and other changes, contents of this Manual may be slightly different from actual situation. The Company is entitled to revise it at any time, and the revised version will be developed without prior notice, please understand that. The copyright of this User's Manual belongs to the Company, and this Manual is not allowed to be reproduced without written consent of the Company, violators must be prosecuted.

This Manual is a permanent part of the generator set. If the generator set is resold, the Manual will be resold together with the generator set.

### **SPECIAL NOTE**

This manual is applicable to multiple models of generators, including operating instructions for recoil start and electric start types. Please refer to the operating steps according to the configuration of the generator you purchased.

---

## **TABLE OF CONTENTS**

---

<b>SAFETY .....</b>	<b>2</b>
<b>NAMES OF COMPONENTS .....</b>	<b>6</b>
<b>CONTROL FUNCTIONS.....</b>	<b>8</b>
<b>PREPARATIONS .....</b>	<b>11</b>
<b>OPERATION .....</b>	<b>13</b>
<b>USING THE GENERATOR .....</b>	<b>18</b>
<b>SERVICE AND MAINTENANCE .....</b>	<b>20</b>
<b>STORAGE AND TRANSPORT .....</b>	<b>24</b>
<b>TROUBLESHOOTING .....</b>	<b>25</b>
<b>TECHNICAL PARAMETERS .....</b>	<b>27</b>

# SAFETY

Personal and property safeties of you and others are very vital. Please read the Safety Warning in the User's Manual and the decals of the generator set carefully.

The Safety Warning can alert you to those potential hazards that could harm you and others. In front of each Safety Warning, there is one of four words "**DANGER**", "**WARNING**", "**ATTENTION**", and "**CAREFUL**". Details are as follows:

## DANGER

Failure to follow the instruction will result in being in peril of your life or extremely serious injury.

## WARNING

Failure to follow the instruction will result in being in peril of your life or very serious injury.

## CAREFUL

Failure to follow the instruction will result in minor injury.

## ATTENTION

Failure to follow the instruction will result in the damage to your generator set and other properties.

## SAFETY PRECAUTIONS

<b>⚠ DANGER</b>	
Using a generator indoors <b>CAN KILL YOU IN MINUTES</b> . Generator exhaust contains carbon monoxide. This is a poison you cannot see or smell.	
	
<b>NEVER</b> use inside a home or garage, <b>EVEN IF</b> doors and windows are open.	Only use <b>OUTSIDE</b> and far away from windows, doors, and vents.

## WARNING

Engine exhaust contains carbon monoxide, a poisonous gas that could kill you in minutes. You **CANNOT** smell it, see it, or taste it. Even if you do not smell exhaust fumes, you could still be exposed to carbon monoxide gas.

- Operate this product **ONLY** outside far away from windows, doors and vents to reduce the risk of carbon monoxide gas from accumulating and potentially being drawn towards occupied spaces.
- Install battery-operated carbon monoxide alarms or plug-in carbon monoxide alarms with battery back-up according to the manufacturer's instructions. Smoke alarms cannot detect carbon monoxide gas.
- **DO NOT** run this product inside homes, garages, basements, crawlspaces, sheds, or other partially-enclosed spaces even if using fans or opening doors and windows for ventilation. Carbon monoxide can quickly build up in these spaces and can linger for hours, even after this product has shut off.
- **ALWAYS** place this product downwind and point the engine exhaust away from occupied spaces. If you start to feel sick, dizzy, or weak while using this product, shut it off and get to fresh air **RIGHT AWAY**. See a doctor. You may have carbon monoxide poisoning.
- If you start to feel sick, dizzy or weak while using the portable generator, you may have carbon monoxide poisoning. Get outside to fresh air immediately and emergency medical assistance.. Very high levels of CO can rapidly cause victims to lose consciousness before they can rescue themselves. **DO NOT** attempt to shut off the generator before moving to fresh air. Entering an enclosed space where a generator is or has been running may put you at greater risk of CO poisoning.

# SAFETY

## CORRECT USAGE

### Example location to reduce risk of carbon monoxide poisoning

- ONLY use outside and downwind, far away from windows, doors and vents.
- Direct exhaust **AWAY** from windows, doors, and vents.



## INCORRECT USAGE

### Do not operate in any of the following locations:

- Near any door, window or vent
- Garage
- Basement
- Crawl Space
- Living Area
- Attic
- Entry Way
- Porch
- Mudroom

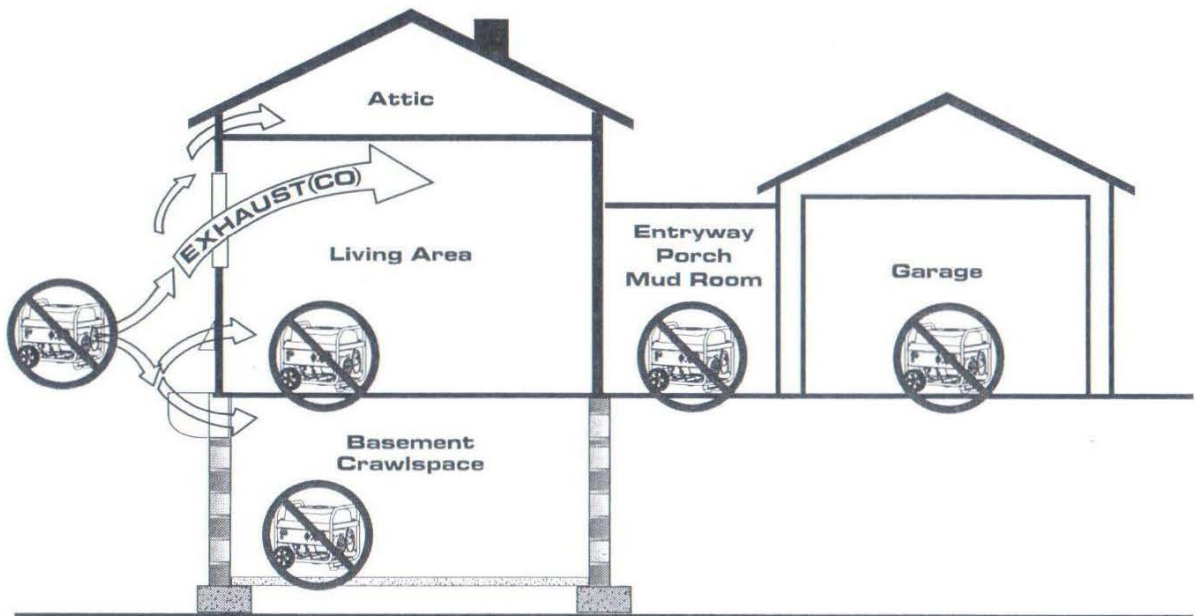

# SAFETY

---

## BEFORE USING THE GENERATOR

- In order to operate the generator correctly, be familiar with the operation of the various components and master the method of shutting down the generator quickly.
- Never use the generator to power medical support equipment.
- Please never modify the generator.
- Please do not use in rain or in areas with water. There is a risk of electric shock when using generators and connected appliances that have been soaked in rain or water, or when operating with wet hands.
- Please never connect wires from the power company. It can cause malfunctions in the machine and connected electrical equipment, becoming the cause of fire or personal accidents.
- The use of generators has laws and regulations, please comply with labor safety and health regulations, fire protection laws, electrical industry laws, etc.
- Please do not connect parallel operation terminals except for dedicated wires. There is a risk of electric shock.

## WHEN ADDING OR DRAINING GASOLINE

Turn the generator engine OFF and let it cool for at least 2 minutes before removing the fuel cap. Loosen the cap slowly to relieve pressure in the tank.

- Fill or drain fuel tank outdoors.
- DO NOT overfill the tank. Allow space for fuel expansion.
- If fuel spills, wipe it up and let the area dry before starting the engine.
- Keep fuel away from sparks, open flames, heat, and other ignition sources.
- Check fuel lines, tank, cap, and fittings frequently for cracks or leaks; replace if necessary.
- DO NOT light a cigarette or smoke anything.

## WHEN STARTING EQUIPMENT

- Ensure spark plug, muffler, fuel cap, and air cleaner are in place.
- DO NOT crank engine with spark plug removed.

## WHEN OPERATING EQUIPMENT

- DO NOT operate this product inside any building, carport, porch, mobile enclosure, marine applications, or shed.
- DO NOT tip engine or equipment at an angle that causes fuel to spill.
- DO NOT stop the engine by moving the choke control to "Start" position.
- DO NOT exceed the generator's wattage capacity.
- Start the generator and let the engine stabilize before connecting electrical loads.
- Connect electrical loads in the OFF position, then turn ON for operation.
- Turn electrical loads OFF and disconnect from the generator before stopping the generator.

## ATTENTION

Improper treatment of the generator could damage it and shorten its life.

- Use generator only for intended applications.
- If you have questions about intended use, ask a dealer.
- Operate generator only on solid, level surfaces.
- DO NOT expose the generator to excessive moisture, dust, dirt, or corrosive vapors.
- DO NOT insert any objects through cooling slots.
- If connected devices overheat, turn them off and disconnect them from the generator.

# SAFETY

---

## PARALLEL KIT PRECAUTIONS

To prevent serious injury, death and damage to generators and/or equipment due to electric shock and fire:

- Follow Parallel Kit instructions provided with Kit for connection and use of a Parallel Kit.
- Only connect two identical Inverter Generators together using a Parallel Kit.
- Connect Parallel Kit only to terminals marked "Parallel Outlets" on the front of the Generator.
- Do not remove or connect a Parallel Kit while the Generator is running.
- Do not use a Parallel Kit that is attached to only one Generator.

## SAFETY PRECAUTIONS FOR GASOLINE AND GASOLINE VAPOR

- Fire and explosion hazard. Gasoline is highly explosive and flammable and can cause severe burns or death.
- Fire and Burn Hazard. NEVER loosen or remove the fuel cap while the generator is running. Turn the unit off and allow it to cool for at least five minutes before adding gasoline. Loosen the fuel cap slowly.
- In case of a gasoline fire, do not attempt to extinguish the flame unless the engine/fuel control switch is in the OFF position. Introducing an extinguisher to a generator with an open fuel valve could create an explosion hazard.

# NAMES OF COMPONENTS

---

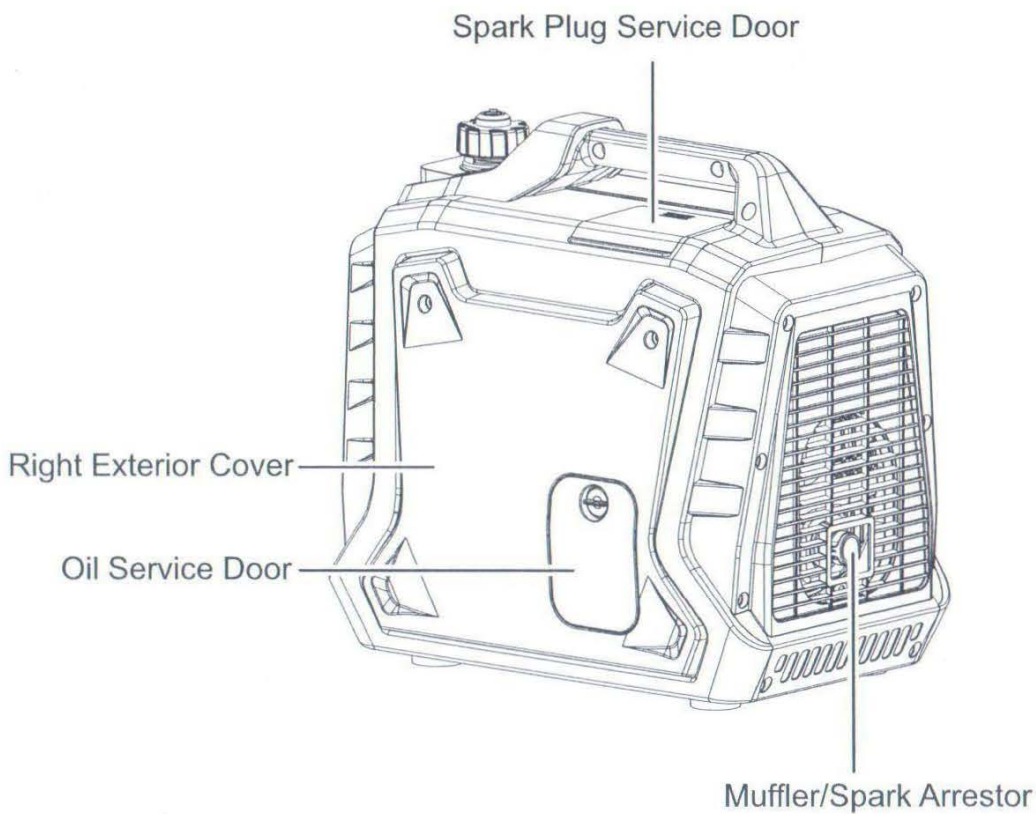
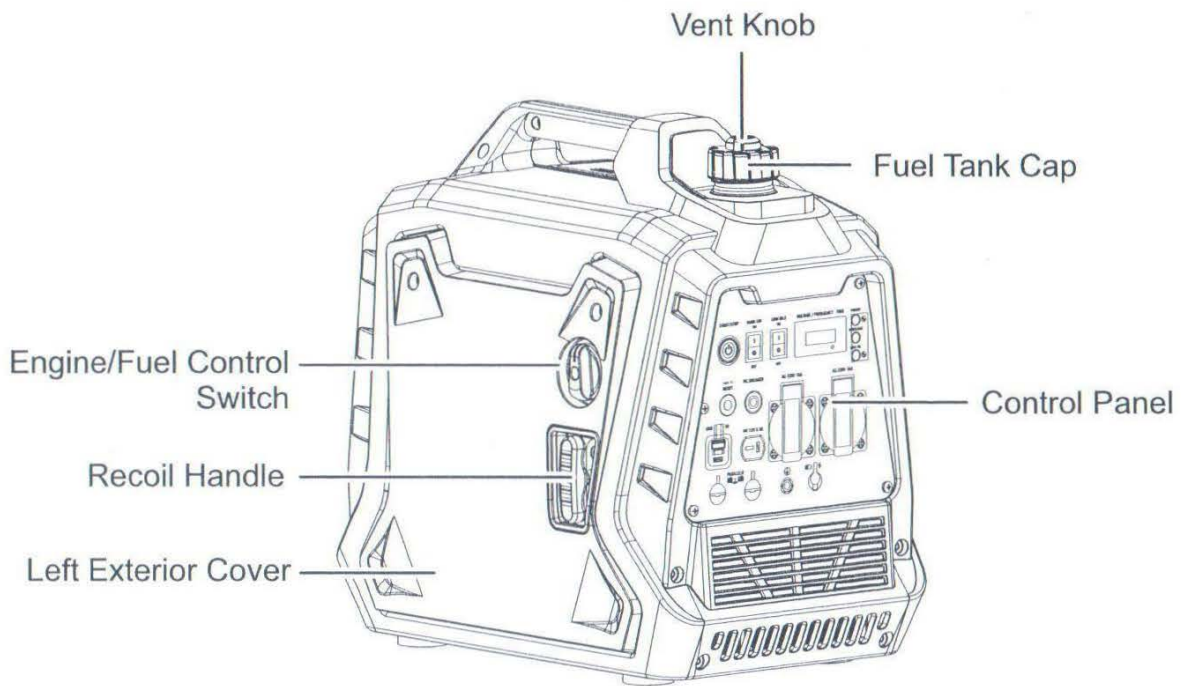

**STATEMENT:** The illustrations used in this manual are intended as representative reference views only.

# NAMES OF COMPONENTS

## Control Panel

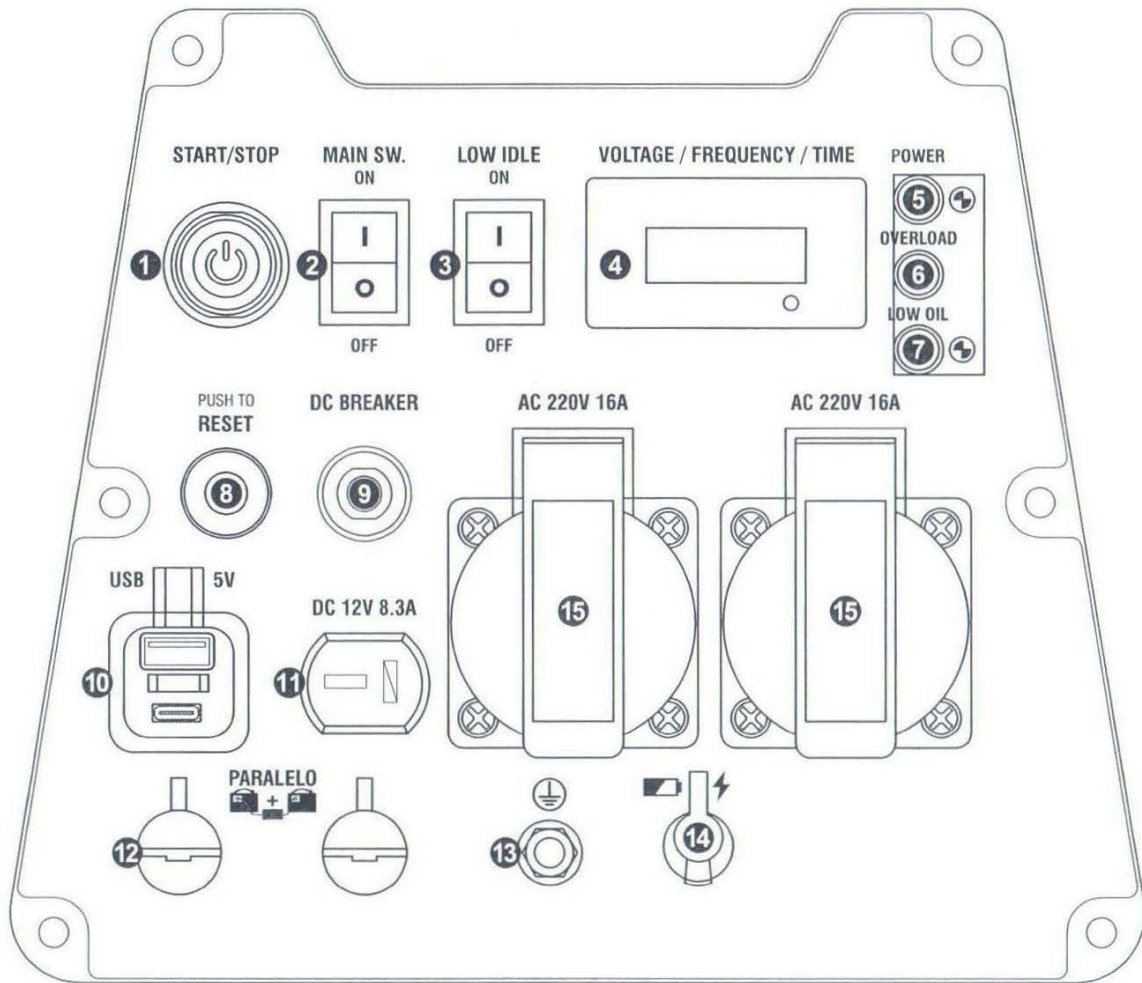

① Start/Stop Button	② Main Switch	③ Low Idle
④ Multifunction Display Meter	⑤ Oil Alarm	⑥ Overload Alarm
⑦ Output Light	⑧ Reset	⑨ DC Breaker
⑩ USB Socket	⑪ DC Socket	⑫ Parallel Socket
⑬ Ground Terminal	⑭ Generator Battery Charging Socket	⑮ AC Socket

# CONTROL FUNCTIONS

**Note:** The product you purchased may not have these configurations, please refer to the actual product.

## Multi-Switch

**OFF** - Ignition circuit is off, the fuel valve is closed, the engine will not run.

**RUN** - Ignition circuit is on, the fuel valve is open, the choke is open, and the engine runs normally.

**START (CHOKE)** - (only used for cold starting) Ignition circuit is on, fuel valve is open, choke is closed.

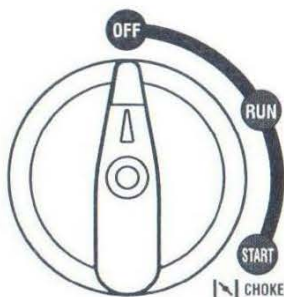

**Multi-Switch**

**NOTICE:** If the engine is hot, do not use the choke.

## Fuel Switch

**OFF** - Turn off fuel supply

**ON** - Open the fuel channel and the engine can start normally.

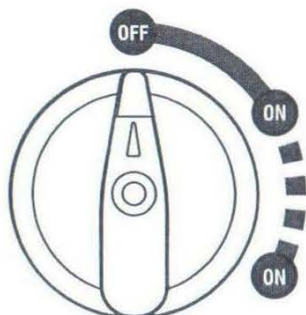

**FUEL SWITCH**

## Main Switch (Engine Switch)

**OFF** - Ignition circuit is off, the engine stopped running.

**ON** - Ignition circuit is on, the start the engine.

**MAIN.SW**

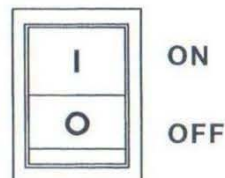

## Start/Stop Switch

Press this button, the engine can start and stop.

**START/STOP**

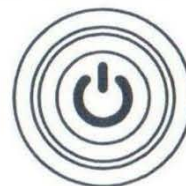

## Remote Control

**OFF** - Generator outage.

**ON** - Generator operation.

### Remote Control Pairing:

1. Long press the start button for more than 5 seconds until the button red indicator is on;
2. Press any key on the remote control;
3. The red indicator of the start button will blink two or three times and then turns off, Remote start pairing is successful.

**Tip:** The remote control delivered with the generator has been paired successfully.

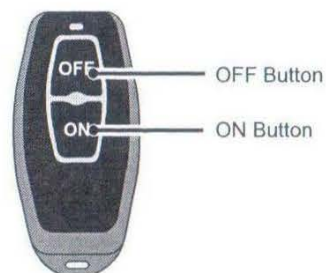

# CONTROL FUNCTIONS

## Oil Indicator (red)



When the oil in the crankcase drops below safety line, oil protection system will automatically shut down the engine, and low oil indicator lights up; the engine can be restarted up only after the oil is filled to oil level.

**Tip:** In the case of flame-out of the engine or being unable to be started up, turn the combination switch to "RUN" position, and then pull startup handle. If low oil indicator flashes a few seconds, the oil volume is insufficient, fill oil and restart it.

## Overload Indicator (red)



When the overload indicator lights up, the generator has detected that the output of connected electrical equipment has been overloaded, causing frequency converter to be overheated or AC voltage to rise. At this moment, AC protector works and stops generating, to protect the generator and connected electrical equipment. AC indicator (green) is off and overload indicator (red) lights up, but the engine will not stop running. When overload indicator is on and the generator has no output, please take following counter measures:

- ① Switch off electrical equipment connected, and shut down the generator.
- ② Reduce total power of electrical equipment connected to the range of rated output.

- ③ Check whether there is any foreign matter blocking in cooling air inlet, and whether there is any abnormality in related control components. If there is any problem, eliminate it immediately.
- ④ After checking, restart the engine.

## Output Indicator (green)

The AC indicator lights when the engine is started and output normally.

## Energy-Saving Switch (LOW IDLE)

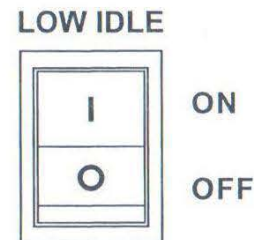

### 1) "ON"

When energy saving switch is switched to "ON" position engine speed is reduced when the generator is under light load. This feature will reduce fuel consumption and noise.

### 2) "OFF"

When the energy saving switch is set to the "OFF" position, the engine will run at rated speed, regardless of connected load.

## Reset

If the inverter is overloaded, the reset breaker will trip. The engine will continue to run, but there will be no output from the inverter. Unplug the devices and reduce the load. Push in the reset breaker to reset it.



# CONTROL FUNCTIONS

## Parallel Connector

To increase AC power output, the connector sockets are used to connect the two same type generator with special paralleling cords. The connector sockets is only used to the communication between the generators, they can not used for AC power output. The special paralleling cords shall be purchase separately, and they shall be approved by certification body.

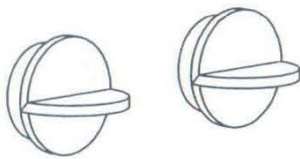

PARALLEL CONNECTOR

## AC Circuit Breaker

If the total AC load exceeds the rated current, the AC circuit breaker will open (trip) and the button will pop out. In this case disconnect all loads, restart the generator and push in the AC circuit breaker(s).



## Ground Terminal

The ground terminal is used to externally ground the generator.

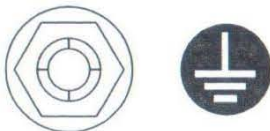

## Battery Charging

Keep the generator battery fully charged and ready to use to avoid the need to use the recoil starter to start the generator manually. The battery shipped with the generator has been partially charged. A battery may lose some charge when not in use for prolonged periods of time.

- Once the generator is started, it will immediately charge the battery.
- When the generator is not running, the attached charger can charge the battery.
- Charge in a dry place.
- The charging time should not exceed 30-40 minutes.

*(Charger sold separately)*

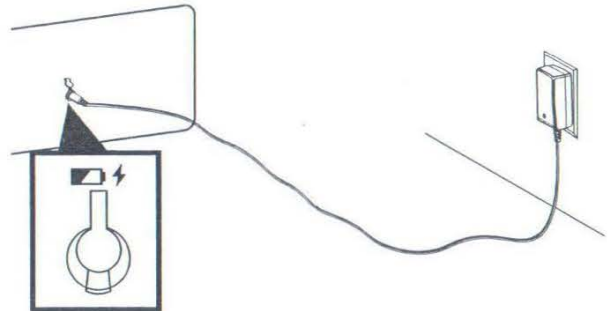

# PREPARATIONS

## ADD GASOLINE

### WARNING



**TO PREVENT SERIOUS INJURY FROM FIRE:** Fill the gasoline tank in a well-ventilated area away from ignition sources. If the engine is hot from use, shut the engine off and wait for it to cool before adding gasoline. Do not smoke.

1. Make sure the generator is on a solid, flat, level surface.
2. Unscrew the fuel cap and set it aside.
3. Slowly add gasoline to the fuel tank. Be careful not to overfill. The fuel gauge on the top of the fuel tank indicates how much gasoline is in the generator fuel tank.

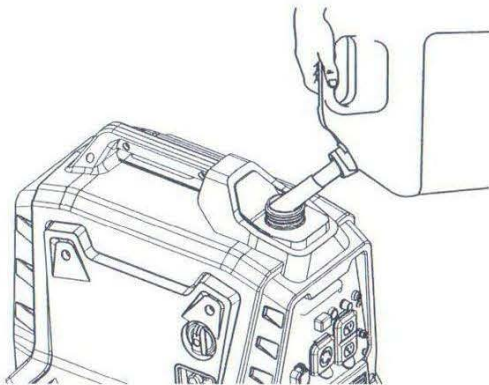

4. Replace the fuel cap and wipe up any spilled gasoline with a dry cloth then remove the cloth from the area.

### DANGER

Do not overfill the gasoline the tank. Overfilling can result in a fire, explosion, or death.

### WARNING

Gasoline can expand. Do not fill the gasoline tank to the top. Leave a minimum of 1.5 inches open space. Gasoline fumes are highly flammable. Do not fill the tank near an open flame. Always check for gasoline spills.

- To ensure the generator runs smoothly, only fresh, unleaded gasoline is used.
- Never use an oil/gasoline mixture. Never use old gasoline.
- Avoid getting dirt or water in the gasoline tank.

- Gasoline can age in the tank and make it hard to start the generator in the future.
- Never store generator for extended periods of time with gasoline in the tank.

## ADD ENGINE OIL

No oil is filled into this generator when being delivered. Do not start up the generator without filing sufficient oil.

1. Please place the generator onto a horizontal plane surface.
2. Open the engine oil service door.

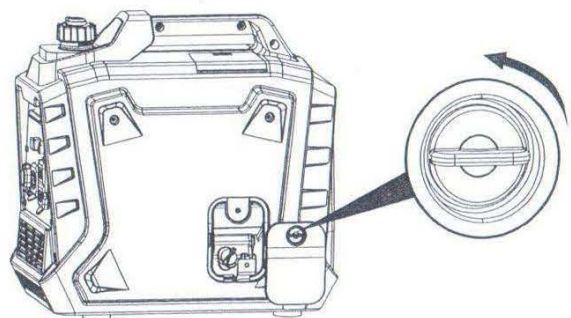

3. Unscrew oil dipstick.
4. Using a funnel, as needed, add the appropriate type of oil until the oil level is at the proper level. SAE 10W-30 oil is recommended for general use.

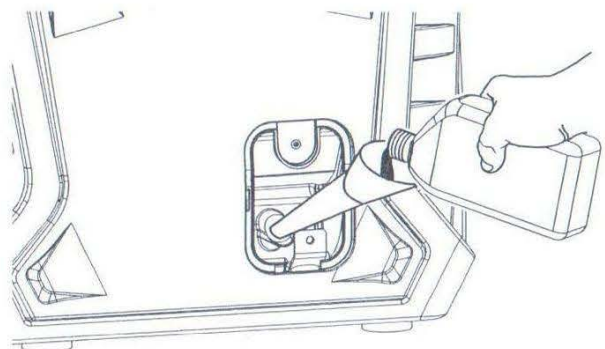

5. Check the engine oil level daily and refuel if necessary. Insert the dipstick again, but do not tighten it, and remove the dipstick again to check the oil level. The oil level should reach the position shown in the figure.

# PREPARATIONS

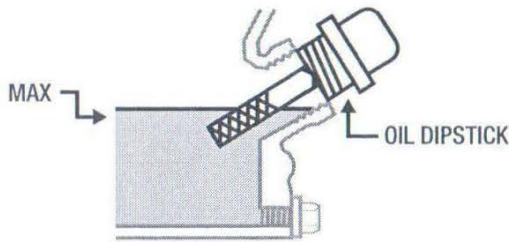

6. After refueling, tighten the dipstick, wipe off the surrounding oil stains, reassemble the service door of the machine.

## ATTENTION

Your generator was functionally tested in the factory and may contain minimum residual oil. Additional oil is required to operate the unit. Do not overfill.

## ATTENTION

The recommended oil type for typical use is 10W-30 automotive oil. However, using the listed conventional oils shown in the "Recommended Engine Oil Type" chart may be used for typical use including the first 5 hours of the break-in run time period of the engine. If running generator in extreme temperatures, refer to the "Recommended Engine Oil Type" chart.

Recommended Engine Oil Type	
°F	-20   0   20   40   60   80   100   120
°C	-28.9   -17.8   -6.7   4.4   15.6   26.7   37.8   48.9
Ambient Temperature	

## CONNECTING THE BATTERY

**Note:** Only electric start type generators need to be connected to the battery cable

1. On the right side of the generator, open the engine service door.

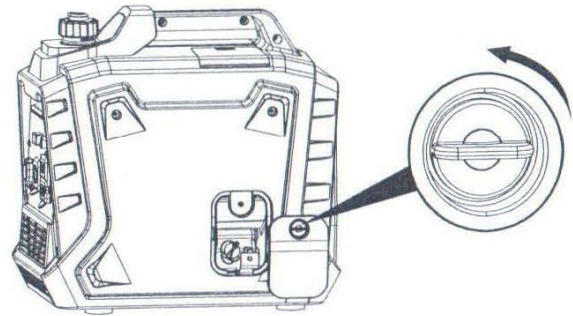

2. A quick-connect battery plug is pre-installed on the battery. Remove the cable tie securing the plugs, align colors, then push firmly to connect them.

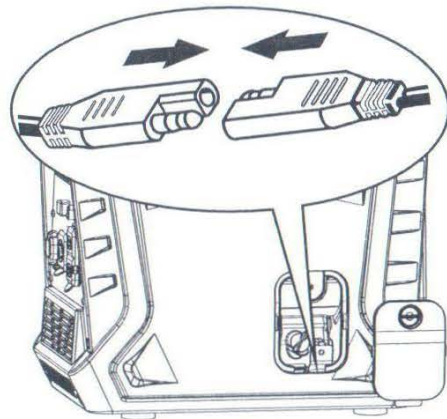

3. Reinstall the service door.

**Note:** The generator is equipped with a battery charging feature. Once the engine is running, a small current will slowly recharge the battery.

# OPERATION

## STARTING THE GENERATOR

### Start the Generator (Recoil Start Type)

1. Make sure the generator is on a solid, flat, level surface.
2. Disconnect all electrical loads from the generator. Never start or stop the generator with electrical devices plugged in or turned on.
3. Turn the fuel tank cover ventilation knob to "ON". (Actual prevail)

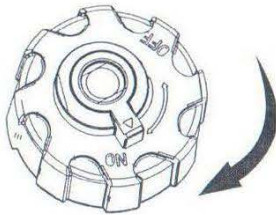

4. Press LOW IDLE to "OFF".

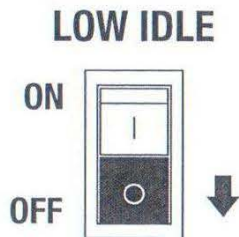

5. Turn the Multi-Switch to "START" ("CHOKE") to start a cold engine.

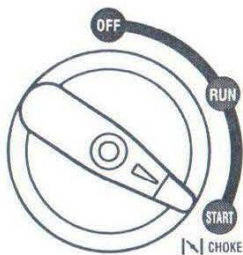

6. Firmly grasp and pull the recoil handle slowly until you feel increased resistance, then pull rapidly.

**Tip:** When pulling the hand starter, hold the generator carrying handle firmly, to prevent the generator from overturning.

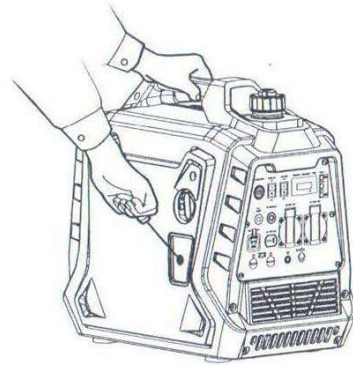

7. With the engine started, turn the Multi-Switch to the "RUN" position.

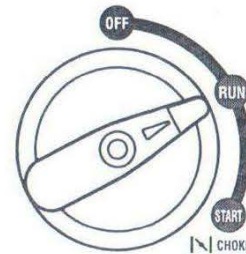

8. After 1-2 minutes of normal operation of the generator, connect the required equipment.

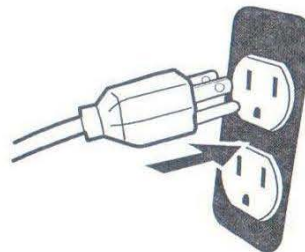

## ATTENTION

For gasoline restarts with hot engine in hot ambient temperature  $>86^{\circ}\text{F}$  ( $30^{\circ}\text{C}$ ): Rotate the Multi-Switch to the "CHOKE" position for only one pull of the recoil cord. If generator does not start after first pull, rotate the dial to the "RUN" position for the next three pulls. Too much choke leads to spark plug fouling and engine flooding. This will cause the engine not to start.

# OPERATION

## ATTENTION

For gasoline starting in standard ambient temperature  $>59^{\circ}\text{F}(15^{\circ}\text{C})$ : Keep Multi-Switch in "CHOKE" position for three pulls of the recoil cord. If generator does not start after three pulls, rotate the Multi-Switch to the "RUN" position for the next three pulls. Too much choke leads to spark plug fouling and engine flooding. This will cause the engine not to start.

## ATTENTION

For gasoline starting in cold ambient temperature  $< 59^{\circ}\text{F}(15^{\circ}\text{C})$ : Keep the Multi-Switch in the "CHOKE" position until engine starts. As soon as the engine starts and runs smoothly turn the Multi-Switch to the "RUN" position. In extreme cold temperatures, this may take several seconds.

## ATTENTION

If the engine starts but does not continue to run make certain that the generator is on a flat, level surface. The engine is equipped with a low oil sensor that will prevent the engine from running when the oil level falls below a critical threshold.

### Start the Generator (Electric Start Type)

1. Make sure the generator is on a solid, flat, level surface.
2. Disconnect all electrical loads from the generator. Never start or stop the generator with electrical devices plugged in or turned on.
3. Turn the Fuel Switch to the "ON" position.

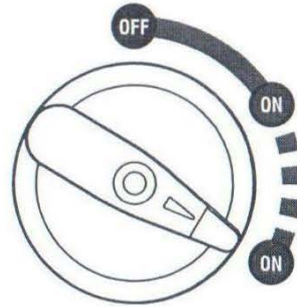

4. Press LOW IDLE to "OFF".

### LOW IDLE

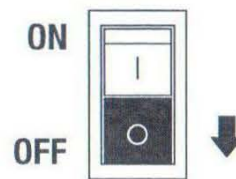

5. Press Main Switch to "ON".

### MAIN SW.

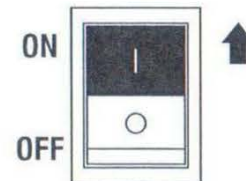

### 6. Choose the Starting Method

**Recoil Start:** Firmly grasp and pull the recoil handle slowly until you feel resistance, let it retract then pull swiftly.

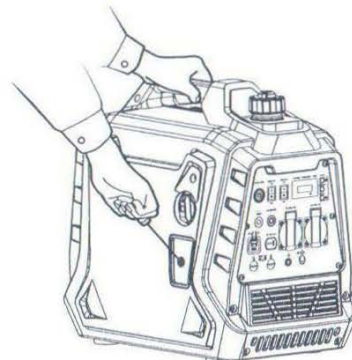

**Push Button Start:** Press the start button for 1-3 seconds, then release, to start the generator.

## OPERATION

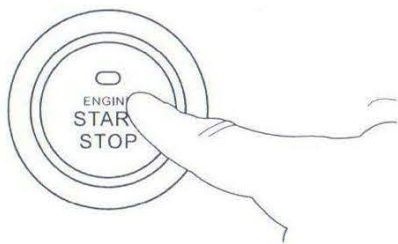

**Remote Start:** Push and hold the ON button on the remote start key fob for one second.

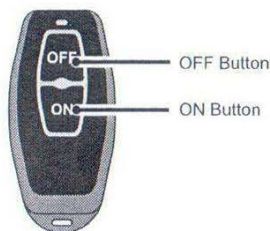

7. After 1-2 minutes of normal operation of the generator, connect the required equipment.

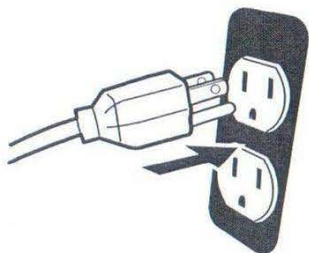

### Parallel Operation

The parallel connection ports allow you to connect two generators to increase the total available electrical power. Follow the instructions included with your parallel connection kit for proper installation and operation.

### Overload Indicator

Note: The OVERLOAD light may turn on for a few seconds as a large device starts. This is normal for loads approaching the capacity of this generator.

1. The total combined load through the outlets on the generator must not exceed the running power of the unit.

2. If the OVERLOAD light turns on and the generator stops producing power, it has been overloaded.
3. Turn off and disconnect all electrical devices and stop the engine. Compare device requirements to generator rating and reduce the total wattage of connected devices if necessary. Move anything that may be limiting generator ventilation away.
4. Check if any circuit breakers have tripped and make sure that ALL circuit breakers are reset before starting the generator again.
5. Restart the engine and reconnect devices while being careful to not overload the generator.

### Low Oil Indicator

1. If the engine oil level is too low, the LOW OIL light turns on and the engine will automatically shut off.
2. The engine cannot be restarted until the proper amount of oil has been added. Add the appropriate type of oil until the oil level is at the proper level. SAE 10w-30 oil is recommended for general use.

## ATTENTION

Do not run the engine with too little oil. Engine will shut off if engine oil level is too low.

### Low Idle

1. Turn on a Low Idle Switch to limit noise and fuel consumption with a light generator load.
2. Turn off the low idle mode to run the engine at full speed under the following conditions:
  - Starting the generator.
  - If the load exceeds 50%, it is recommended to turn off the low idle mode.

# OPERATION

## STOPPING THE GENERATOR

### Stop the Generator (Recoil Start Type)

1. Turn off and unplug all connected electrical loads. Never start or stop the generator with electrical devices plugged in or turned on.

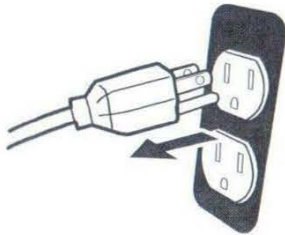

2. Turn the Multi-Switch to "OFF" position.

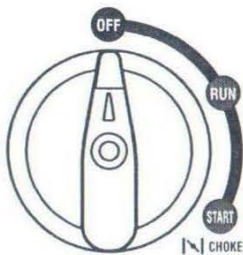

3. Turn the fuel tank cover ventilation knob to "OFF". (Actual prevail)

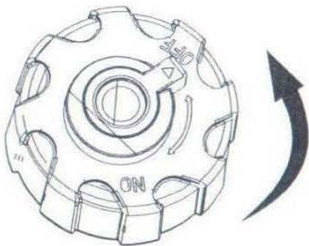

4. Remove or consume all untreated gasoline if you plan to store the generator longer than 3 months.

### Stop the Generator (Electric Start Type)

1. Turn off and unplug all connected electrical loads. Never start or stop the generator with electrical devices plugged in or turned on.

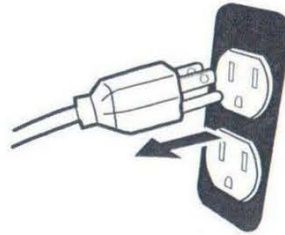

2. Select the Stopping Mode:

**Button Start:** Press the button to turn off the generator.

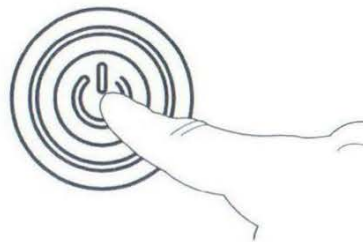

**Remote Stop:** Hold down the OFF button on the remote start key for one second.

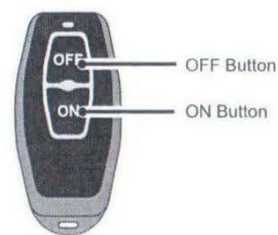

3. Press the Main Switch to "OFF".

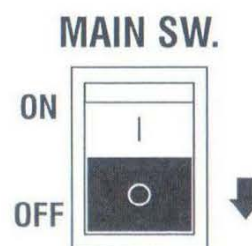

## OPERATION

---

4. Turn the Fuel Selector knob to the OFF position.

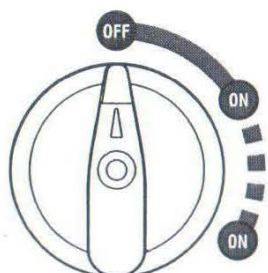

5. Turn the fuel tank cover ventilation knob to "OFF". (Actual prevail)

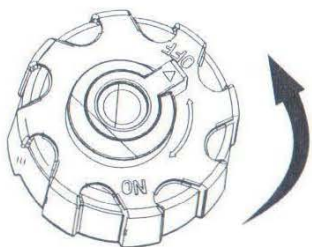

6. If the generator is not used for a long time, please disconnect the battery wiring.

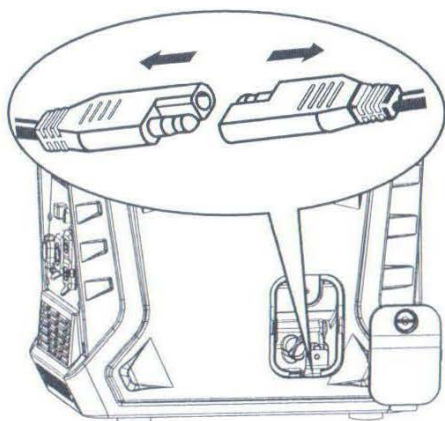

7. Remove or consume all untreated gasoline if you plan to store the generator longer than 3 months.

# USING THE GENERATOR

## SERVICE ENVIRONMENT OF THE GENERATOR

- Applicable temperature: 23°F(-5°C)~104°F(40°C);
- Applicable humidity: below 95%;
- Applicable altitude: regions below 1,500 m (It shall be used by reducing power in regions above 1,000 m).

### Standard atmospheric condition

- Ambient temperature  $T_r$ : 298k (77°F)(25°C)
- Relative air humidity  $\Phi_r$ : 30%.
- Absolute atmospheric pressure  $P_r$ : 100kPa

### When actual environmental condition is inconsistent with the condition of output power of the generator set:

- Every 41°F(5°C) of increase in ambient temperature will reduce the power of generator by about 2%
- Every 30% of increase in relative humidity of air will reduce the power of generator by about 1.5%
- Every 300 m rising of ASL will reduce the power the generator by about 4.5%

## GENERATOR WIRING

- When the generator is connected to household power source as a backup power supply, the connection shall be carried out by a professional electrician or a person familiar with electricity.
- After connecting the load to the generator, check carefully whether electrical connection is safe and reliable. Improper electrical connection may cause generator damage, burning or fire.
- Avoid connecting this generator to commercial power outlet.
- When extending the cable, be sure not to exceed its length.
  - ① 60m cross-section area is 1.5mm<sup>2</sup>
  - ② 100m cross-section area is 2.5mm<sup>2</sup>
- The appearance of extension cable shall be protected by a layer of tough and elastic rubber cover (IEC25) or other substitutes.

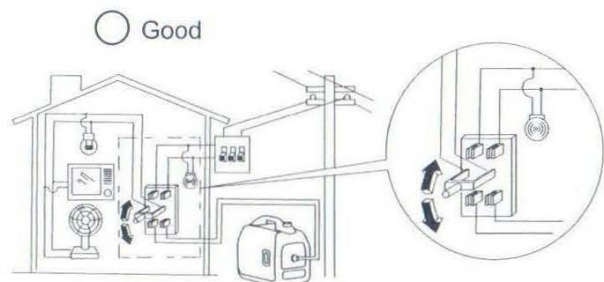
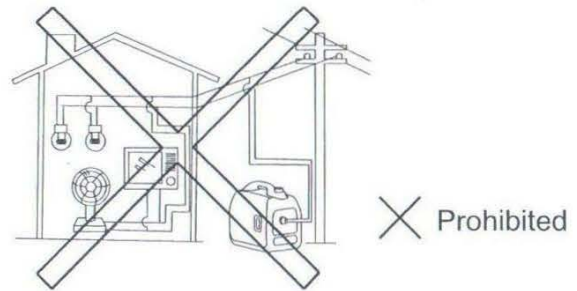
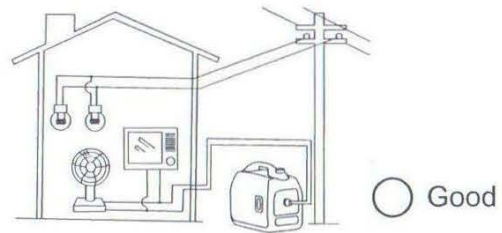

### Connection of AC power

**WARNING** All electrical equipment shall be disconnected before inserting the plug.

### ATTENTION

- Make sure that all electrical equipment, including wires and plugs, are in good condition before connecting to the generator;
- Make sure that all loads driven by the generator are within rated load range;
- Make sure that load current is within rated current range of rated socket.

**Tip:** Make sure that the generator set is grounded, and if electrical equipment requires grounding, the generator set must be grounded.

## USING THE GENERATOR

- ① Start up the engine;
- ② Turn energy-saving switch to "ON" ;
- ③ Insert the plug into AC outlet;
- ④ Make sure that AC indicator is lit up;
- ⑤ Switch on electrical equipment.

**Tip:** Before increasing engine speed, low idle switch must be switched to "OFF". If the generator set supplies power to multi loads or electrical equipment, start from large to small according to the size of each electrical equipment.

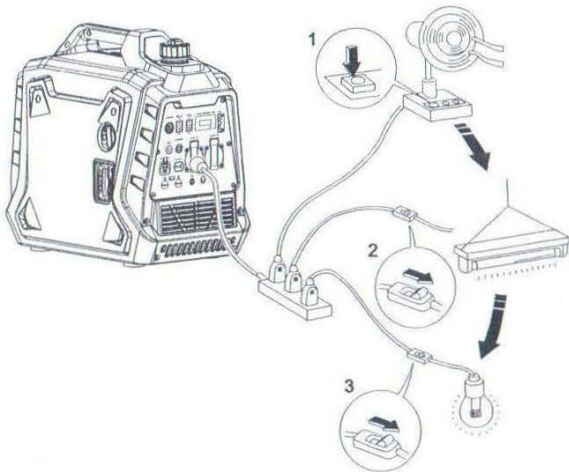

### Generator Grounding

In order to prevent any damage to the generator caused by electric shock or improper electrical application, it is recommended that the generator is grounded with good conductor with insulating sheath.

- ① Please use grounding wire with sufficient electrical energy capacity;
- ② Connect one end of grounding wire reliable to grounding bolt on control panel of the generator set;
- ③ Insert grounding body (iron rod with a diameter of 5 ~ 10mm) 200mm below into the earth and lead it out with conductor;
- ④ Connect the other end of the grounding wire reliable to the led wire of grounding body.

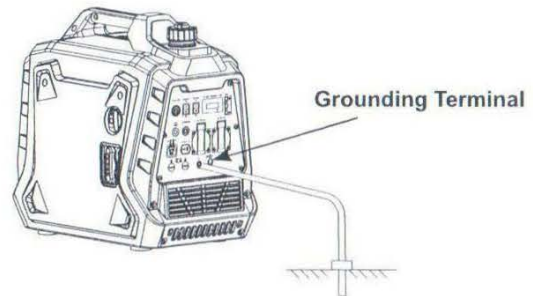

### RANGE OF APPLICATION

Before using the generator, please make sure that total load is within rated load range of the generator, otherwise the generator may be damaged.

#### Tip:

- AC and DC can be used at the same time, but total power amount shall not exceed rated output power.
- When total power exceeds rated power, overload indicator will light up.

## SERVICE AND MAINTENANCE

Good maintenance and service is the best guarantee for safe, economical and reliable operation. It also contributes to environmental protection.

In order to keep the generator in good condition, you must inspect and maintain it regularly. The maintenance schedule is as follows:

Maintenance cycle		Each	First in 1 month or 20 hours	Then every three months or every 50 hours	100 hours per year or use
Engine oil	Check-fill	√			
	Replace		√	√	
Gearbox gear Oil (if any)	Check oil	√			
	Replace		√	√	
Air cleaner element	Inspection	√			
	Clean		√		
	Replace			√	
Settling cup (if any)	Clean				√
Spark plug	Clean-adjust				√*
Spark eliminator	Clean			√	
Idle speed (if any)**	Check-adjust				√
Valve clearance**	Check-adjust				√
Fuel tank and fuel filter***	Clean				√
Fuel line	Inspection	Every two years (Please replace if necessary)			
Cylinder head, piston	Remove carbon deposit**	Displacement < 225cc, every 125 hours; displacement capacity ≥ 225cc, every 250 hours.			
<p>* These items shall be replaced if necessary;</p> <p>** These items shall be maintained by the dealer authorized by the Company, unless the user has proper tools and maintenance ability.</p>					

# SERVICE AND MAINTENANCE

## ATTENTION

- If it often works under high temperature or high load, oil shall be changed every 25 hours;
- If it often works in dusty or harsh environment, air cleaner element shall be cleaned every 10 hours. If necessary, the air cleaner element shall be replaced every 25 hours;
- It shall be maintained on spot-inspection or on regularly scheduled inspections;
- If maintenance cycle time has elapsed, perform the maintenance as soon as possible as per the table above.

## WARNING

Please shut down the engine first before performing any maintenance. The engine shall be placed in a horizontal position. In order to prevent the engine from starting up, separate spark plug cap shall be separated from spark plug.

Do not use it indoors or use it in a tunnel, cave or other places ventilated poorly. Make sure that work area is well ventilated. Exhaust gas from the engine contains toxic gases, carbon oxides, and the inhalation can cause shock, loss of consciousness, and even death.

## SPARK PLUG INSPECTION

Spark plug is an important part of the generator, which must be inspected regularly.

1. Remove spark plug service door and spark plug cap of the generator.

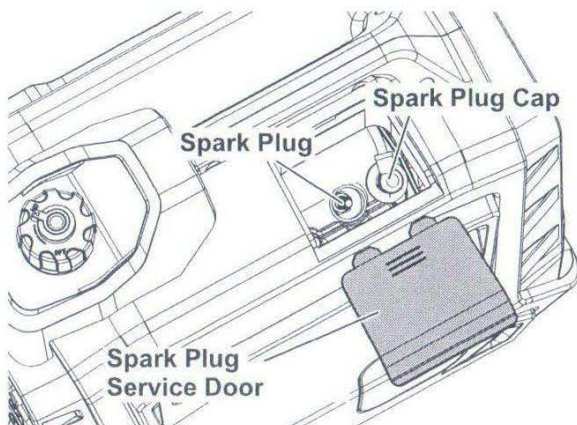

2. Insert the screwdriver into the sleeve, to screw it counterclockwise, and then remove the spark plug.

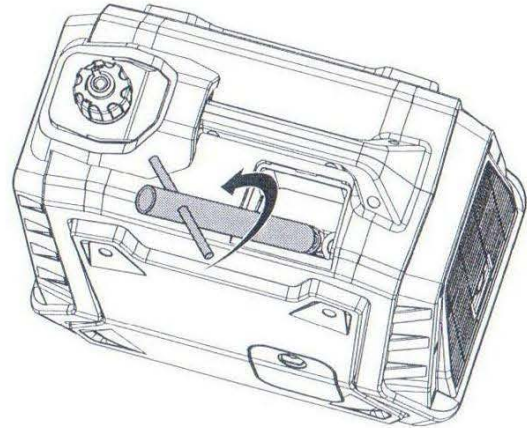

3. Inspect the Spark Plug: If the electrode is oily, clean it using a clean, dry rag. If the electrode has deposits on it, clean it with a brass wire brush. If the white insulator is cracked or chipped, replace the spark plug.
4. Check the model of spark plug and clearance.

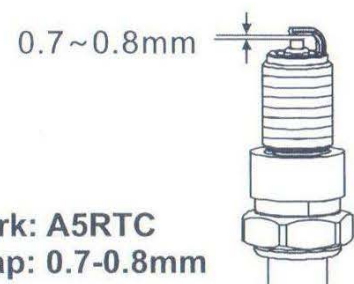

**Standard spark: A5RTC**  
**Spark plug gap: 0.7-0.8mm**

**Tip:** The spark plug clearance is required to be measured by line thickness gauge, which shall be adjusted if necessary.

5. Installation of spark plug.

**Spark cold torque: 12.5 N.m**

**Tip:** If there is no torque wrench when installing the spark plug, a better estimation method is to screw it 1/4-1/2 turns by force after screwing it in place, but the spark plug shall be screwed to specified torque as soon as possible.

# SERVICE AND MAINTENANCE

## REPLACEMENT OF OIL

### WARNING

Do not drain the oil immediately after turning off the generator. During operation, the oil is very hot and can cause serious burns.

1. Place the generator on a horizontal plane and start the generator for several minutes to increase its temperature, then stop the generator.
2. Open the engine oil service door.

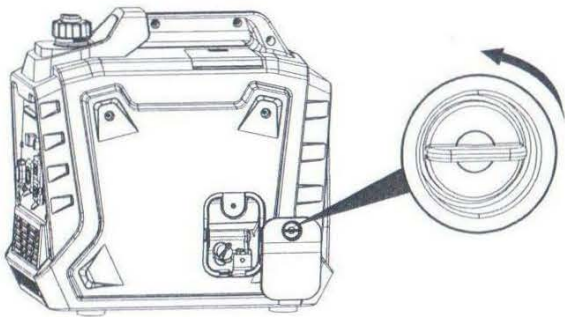

3. Unscrew oil dipstick.
4. Place an oil pan under the engine, tilt the generator to quickly pour out oil.

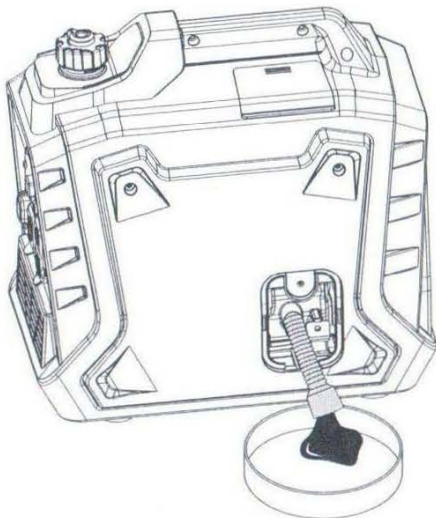

**ATTENTION:** When fling oil, do not tilt the generator frequently to prevent damage to the power by filling too much oil.

5. Using a funnel, as needed, add the appropriate type of oil until the oil level is at the proper level. SAE 10W-30 oil is recommended for general use.

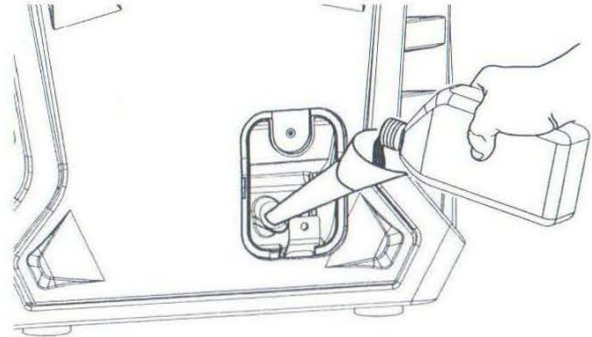

6. Check the engine oil level daily and refuel if necessary. Insert the dipstick again, but do not tighten it, and remove the dipstick again to check the oil level. The oil level should reach the position shown in the figure.

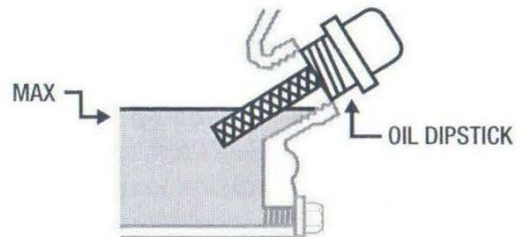

7. Assemble service door.

## AIR FILTER

Dirty air cleaner may prevent air from flowing into the carburetor. In order to prevent failure of the carburetor, please maintain air cleaner regularly. If being used in a dusty environment, it shall be maintained frequently.

1. Loosen the bolt and remove the right exterior cover plate.

# SERVICE AND MAINTENANCE

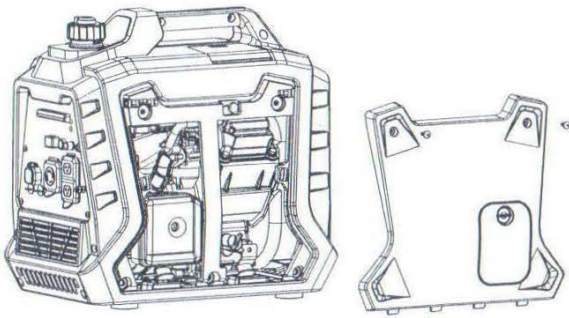

2. Remove screws, to remove cover plate of air cleaner.
3. Remove foam cleaner element.

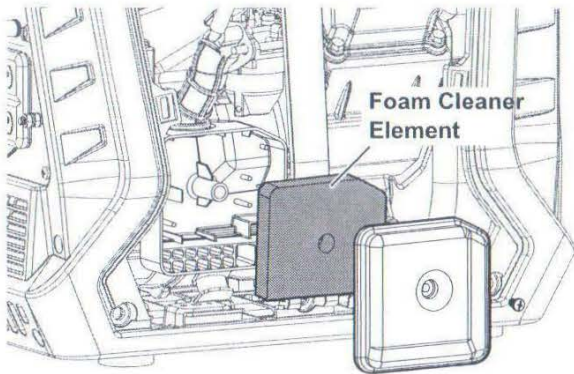

4. Clean the components with cleaning agent. After cleaning, wrap the components in a cloth and screw them dry.

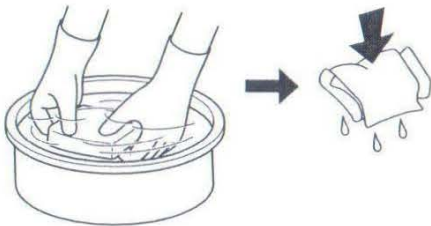

5. Drip a few drops of oil to foam filter element and squeeze off excess oil. The foam cleaner element shall be wet, but there shall not be oil dripping.

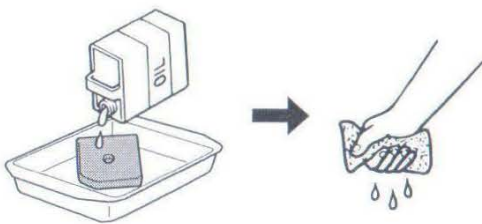

## ATTENTION

Be sure not to twist the foam cleaner element forcibly to avoid damage.

6. Put foam cleaner element into air cleaner.

**Tip:** Make sure that the surface of foam cleaner element is in close contact with air cleaner, and there shall be no gap leaking air.

7. Reassemble empty air cleaner cap back to original position, and tighten screws.
8. Assemble right exterior cover plate and tighten the bolt.

## ATTENTION

Be sure not to start the engine before air cleaner is assembled, because it will generate excessive toxic gas and wear the cylinder.

## FUEL FILTER SCREEN

### WARNING

Be sure not to open fuel tank of the generator in a place where smoking or with flame.

1. Remove fuel tank cap and fuel tank filter screen.
2. Clean fuel tank filter screen with gasoline;
3. Wipe filter screen dry, and put it back into fuel tank.
4. Reassemble fuel tank cap.

**ATTENTION:** Be sure to screw fuel tank cap tight.

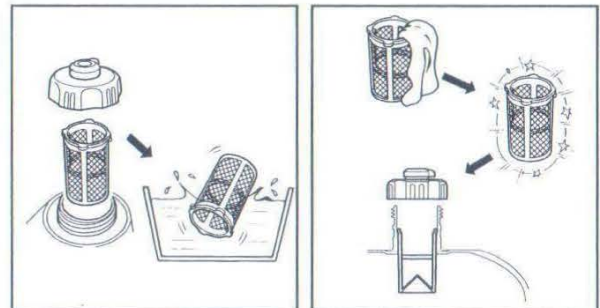

# STORAGE AND TRANSPORT

## GENERATOR STORAGE

If it is stored long-term, in order to prevent aging, you shall take some storage measures.

1. Turn off the generator.
2. Open fuel tank cap, to take out fuel filter screen. Pump all fuel in fuel tank into special fuel tank, and then reassemble fuel tank cap back.

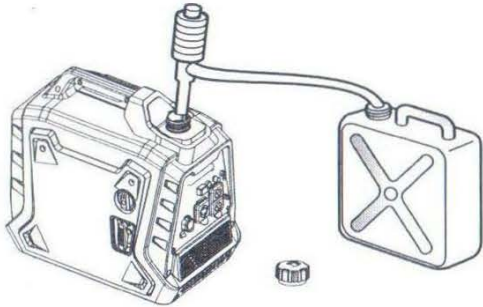

3. Start up the engine to burn off fuel in the carburetor, and then shut it down.

**Tip:** Do not connect any electrical equipment. Running time of the engine depends on remaining fuel in the fuel tank.

4. Unscrew fuel drain bolt on the carburetor, and drain fuel in the carburetor into special fuel tank. Tighten fuel drain bolt.

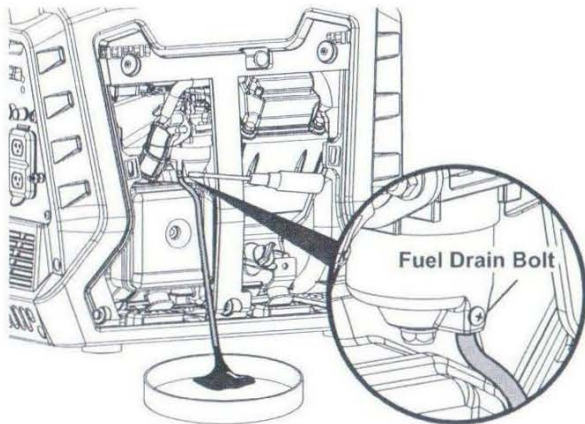

5. Unscrew oil dipstick, and drain oil in the crankcase off. Fill new oil to upper oil limit, and then assemble oil dipstick.
6. Remove the spark plug and pour 5-10ml of clean oil into the combustion chamber. Turn the crankshaft a few times to distribute the oil, then reassemble the spark plug.

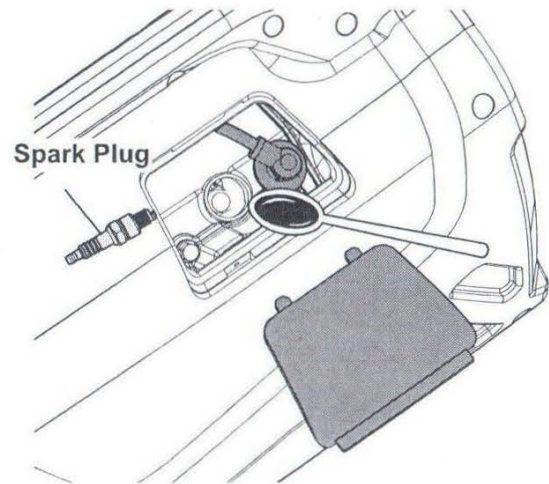

7. Gently pull startup handle until you feel resistance, allowing both inlet valve and exhaust valve to be closed.
8. Place the generator set in a clean and dry area.

## GENERATOR TRANSPORT

- When the generator set is transported, it shall be ensured that there is no fuel spilling.
- Do not fill excessive fuel into fuel tank.
- Do not run the generator, and avoid direct sunlight.
- Do not transport the generator set on rough road for long time.

## PREPARATION FOR USE AFTER STORAGE

1. Slowly pull the starter cord a few times to clean oil from the cylinder or to eject any pump protector from the pump which may have been added prior to storage.
2. Remove the spark plug from the cylinder. Wipe oil from the spark plug and return it to the cylinder and re-tighten.
3. Reconnect the spark plug wire.
4. Refuel engine per earlier instructions in this manual.

# TROUBLESHOOTING

Problem	Possible Causes	Probable Solutions
Engine will not start	<b>FUEL RELATED:</b> <ol style="list-style-type: none"> <li>No fuel in tank or fuel valve closed.</li> <li>Choke not in START position, cold engine.</li> <li>Gasoline with more than 10% ethanol used. (E15, E20, E85, etc.)</li> <li>Low quality or deteriorated, old gasoline.</li> <li>Carburetor not primed.</li> <li>Dirty fuel passageways.</li> <li>Carburetor needle stuck. Fuel can be smelled in the air.</li> <li>Too much fuel in chamber. This can be caused by the carburetor needle sticking.</li> <li>Clogged Fuel Filter.</li> </ol>	<b>FUEL RELATED:</b> <ol style="list-style-type: none"> <li>Fill fuel tank with fresh 87+ octane stabilizer-treated unleaded gasoline and open fuel valve. <b>Do not use gasoline with more than 10% ethanol (E15, E20, E85, etc.).</b></li> <li>Move Choke to START position.</li> <li>Clean out ethanol rich gasoline from fuel system. Replace components damaged by ethanol. Use fresh 87+ octane stabilizer-treated unleaded gasoline only. <b>Do not use gasoline with more than 10% ethanol (E15, E20, E85, etc.).</b></li> <li>Use fresh 87+ octane stabilizer-treated unleaded gasoline. <b>Do not use gasoline with more than 10% ethanol (E15, E20, E85, etc.).</b></li> <li>Pull on Starter Handle to prime.</li> <li>Clean out passageways using fuel additive. Heavy deposits may require further cleaning.</li> <li><b>Gently</b> tap side of carburetor float chamber with screwdriver handle.</li> <li>Turn Choke to RUN position. Remove spark plug and pull the start handle several times to air out the chamber. Reinstall spark plug and set Choke to START position.</li> <li>Replace Fuel Filter.</li> </ol>
	<b>IGNITION (SPARK) RELATED:</b> <ol style="list-style-type: none"> <li>Power Switch at OFF position.</li> <li>Spark plug cap not connected securely.</li> <li>Spark plug electrode wet or dirty.</li> <li>Incorrect spark plug gap.</li> <li>Spark plug cap broken.</li> <li>Circuit breaker tripped (electric start models only).</li> <li>Incorrect spark timing or faulty ignition system.</li> </ol>	<b>IGNITION (SPARK) RELATED:</b> <ol style="list-style-type: none"> <li>Turn Power Switch to ON.</li> <li>Connect spark plug cap properly.</li> <li>Clean spark plug.</li> <li>Correct spark plug gap.</li> <li>Replace spark plug cap.</li> <li>Reset circuit breaker. Check wiring and starter motor if breaker continues to trip.</li> <li>Have qualified technician diagnose/repair ignition system.</li> </ol>
	<b>COMPRESSION RELATED:</b> <ol style="list-style-type: none"> <li>Cylinder not lubricated. Problem after long storage periods.</li> <li>Loose or broken spark plug. (Hissing noise will occur when trying to start.)</li> <li>Loose cylinder head or damaged head gasket. (Hissing noise will occur when trying to start.)</li> <li>Engine valves or tappets mis-adjusted or stuck.</li> </ol>	<b>COMPRESSION RELATED:</b> <ol style="list-style-type: none"> <li>Pour tablespoon of oil into spark plug hole. Crank engine a few times and try to start again.</li> <li>Tighten spark plug. If that does not work, replace spark plug. If problem persists, may have head gasket problem, see #3.</li> <li>Tighten head. If that does not remedy problem, replace head gasket.</li> <li>Have qualified technician adjust/repair valves and tappets.</li> </ol>
	<b>ENGINE OIL RELATED:</b> <ol style="list-style-type: none"> <li>Low engine oil.</li> <li>Engine mounted on slope, triggering low oil shutdown.</li> </ol>	<b>ENGINE OIL RELATED:</b> <ol style="list-style-type: none"> <li>Fill engine oil to proper level. Check engine oil before EVERY use.</li> <li>Operate engine on level surface. Check engine oil level.</li> </ol>
	<b>SPARK ARRESTOR RELATED:</b> <ol style="list-style-type: none"> <li>Spark Arrestor clogged with soot.</li> </ol>	<b>SPARK ARRESTOR RELATED:</b> <ol style="list-style-type: none"> <li>Clean and replace Spark Arrestor.</li> </ol>



Follow all safety precautions whenever diagnosing or servicing the generator or engine.

The table is a general troubleshooting method. If the fault is inconsistent with the table or the fault cannot be resolved, contact the distributor.

# TROUBLESHOOTING

Problem	Possible Causes	Probable Solutions
Engine misfires	<ol style="list-style-type: none"> <li>1. Spark plug cap loose.</li> <li>2. Incorrect spark plug gap or damaged spark plug.</li> <li>3. Defective spark plug cap.</li> <li>4. Old or low quality gasoline.</li> <li>5. Incorrect compression.</li> </ol>	<ol style="list-style-type: none"> <li>1. Check cap and wire connections.</li> <li>2. Re-gap or replace spark plug.</li> <li>3. Replace spark plug cap.</li> <li>4. Use only fresh 87+ octane stabilizer-treated unleaded gasoline. <b>Do not use gasoline with more than 10% ethanol (E15, E20, E85, etc.).</b></li> <li>5. Diagnose and repair compression. (Use <b>Engine will not start: COMPRESSION RELATED</b> section.)</li> </ol>
Engine stops suddenly	<ol style="list-style-type: none"> <li>1. Carbon Monoxide level high. Red light on Carbon Monoxide Sensor illuminates.</li> <li>2. CO Sensor Alarm flashes yellow continually shortly after starting.</li> <li>3. CO Sensor Alarm flashes yellow continually after longer period of operation.</li> <li>4. Low oil shutdown.</li> <li>5. Fuel tank empty or full of impure or low quality gasoline.</li> <li>6. Defective fuel tank cap creating vacuum, preventing proper fuel flow.</li> <li>7. Faulty magneto.</li> <li>8. Disconnected or improperly connected spark plug cap.</li> </ol>	<ol style="list-style-type: none"> <li>1. Leave area immediately and allow area to ventilate thoroughly. Only operate generator outside.</li> <li>2. Carbon monoxide sensor malfunction. Sensor needs service. Do not use the Generator until the sensor is working properly.</li> <li>3. Make sure to operate generator within rated ambient temperature; maintain minimum 5 ft. clearance from all sides.</li> <li>4. Fill engine oil to proper level. Check engine oil before EVERY use.</li> <li>5. Fill fuel tank with fresh 87+ octane stabilizer treated unleaded gasoline. Do not use gasoline with more than 10% ethanol (E15, E20, E85, etc.).</li> <li>6. Test/replace fuel tank cap.</li> <li>7. Have qualified technician service magneto.</li> <li>8. Secure spark plug cap.</li> </ol>
Engine stops when under heavy load	<ol style="list-style-type: none"> <li>1. Dirty air filter</li> <li>2. Engine running cold.</li> </ol>	<ol style="list-style-type: none"> <li>1. Clean element.</li> <li>2. Allow engine to warm up prior to operating equipment.</li> </ol>
Engine knocks	<ol style="list-style-type: none"> <li>1. Old or low quality gasoline.</li> <li>2. Engine overloaded.</li> <li>3. Incorrect spark timing, deposit buildup, worn engine, or other mechanical problems.</li> </ol>	<ol style="list-style-type: none"> <li>1. Fill fuel tank with fresh 87+ octane stabilizer-treated unleaded gasoline. <b>Do not use gasoline with more than 10% ethanol (E15, E20, E85, etc.).</b></li> <li>2. Do not exceed equipment's load rating.</li> <li>3. Have qualified technician diagnose and service engine.</li> </ol>
Engine backfires	<ol style="list-style-type: none"> <li>1. Impure or low quality gasoline.</li> <li>2. Engine too cold.</li> <li>3. Intake valve stuck or overheated engine.</li> <li>4. Incorrect timing.</li> </ol>	<ol style="list-style-type: none"> <li>1. Fill fuel tank with fresh 87+ octane stabilizer-treated unleaded gasoline. <b>Do not use gasoline with more than 10% ethanol (E15, E20, E85, etc.).</b></li> <li>2. Use cold weather fuel and oil additives to prevent backfiring.</li> <li>3. Have qualified technician diagnose and service engine.</li> <li>4. Check engine timing.</li> </ol>
Attached device doesn't have power	<ol style="list-style-type: none"> <li>1. Device not plugged in properly.</li> <li>2. Circuit Breaker tripped.</li> <li>3. Product needs service.</li> </ol>	<ol style="list-style-type: none"> <li>1. Turn off and unplug the device, then plug it back in again and turn on.</li> <li>2. Turn off and unplug device, reset Circuit Breaker, plug in device and turn on.</li> <li>3. Have product repaired.</li> </ol>
Attached device begins to operate abnormally	<ol style="list-style-type: none"> <li>1. Problem with device.</li> <li>2. Rated load capacity exceeded.</li> </ol>	<ol style="list-style-type: none"> <li>1. Immediately unplug device. Have device repaired by a qualified technician, or replace device.</li> <li>2. Lower the number of items plugged into the generator to stay within the rated capacity, or use a more powerful generator.</li> </ol>



Follow all safety precautions whenever diagnosing or servicing the generator or engine.

The table is a general troubleshooting method. If the fault is inconsistent with the table or the fault cannot be resolved, contact the distributor.