

OMTF è la serie delle linee di ritorno; la gamma comprende quattro diverse dimensioni con portate nominali fino a 500 L/min. Gli elementi filtranti sono realizzati con i materiali più avanzati, a garanzia di un'alta efficienza di filtrazione e di una lunga durata.

OMTF is the series of return lines; the range includes four different sizes with nominal flow rates up to 500 L/min.

Filter elements are made with the most advanced materials, as a guarantee for a high filtration efficiency and a long-lasting life.



OMTF

FILTRI SUL RITORNO
RETURN FILTERS



CONDIZIONI DI ESERCIZIO

Pressioni corpo filtro Pressione massima d'esercizio:
0.8 MPa (8 bar)
Pressione di scoppio:
1.0 MPa (10 bar)

Temperatura d'esercizio da -25 a +110°C

Compatibilità con i liquidi - ISO 2943 Compatibili con oli minerali tipo (HH, HM, HR, HV, HG secondo ISO 6743/4)

WORKING CONDITIONS

Filter pressure Maximum working pressure
0.8 MPa (8 bar)
Burst pressure:
1.0 MPa (10 bar)

Working temperature -25 to +110 °C

Compatibility with hydraulic fluids ISO 2943 Compatible with mineral oils type (HH, HM, HR, HV, HG (according to ISO 6743/4)

CORPO FILTRO

Testina Pressofusione di Alluminio
Contenitore OMTF09-11-17: Nylon caricato vetro
OMTF22: Acciaio con trattamento cataforesi
Attacchi ½"÷2" BSP (altre filettature su richiesta)
Guarnizioni N: Nitrilica (Buna-N)

FILTER HOUSING

Head/Cover Die-Casting Aluminium
Filter bowl OMTF09-11-17: Glass reinforced nylon
OMTF22: Cataphoresis treated steel
Connection Ports ½"÷2" BSP (other sizes on request)
Seals N: Nitrile (Buna-N)

ELEMENTO FILTRANTE

Fondelli Lamiera zincata
Tubo di sostegno Ferro zincato
Materiale Filtrante Carta, Fibra Inorganica, Tela (AISI304)
Taratura
Valvola By-Pass 0.17 MPa ± 10% (1.7bar)

FILTER ELEMENT

End caps Galvanized sheet
Support tube Galvanized Steel
Filtration Media Paper, inorganic Fiberglass, Wire Mesh (AISI304)
Setting
By-Pass Valve 0.17 MPa ± 10% (1.7bar)

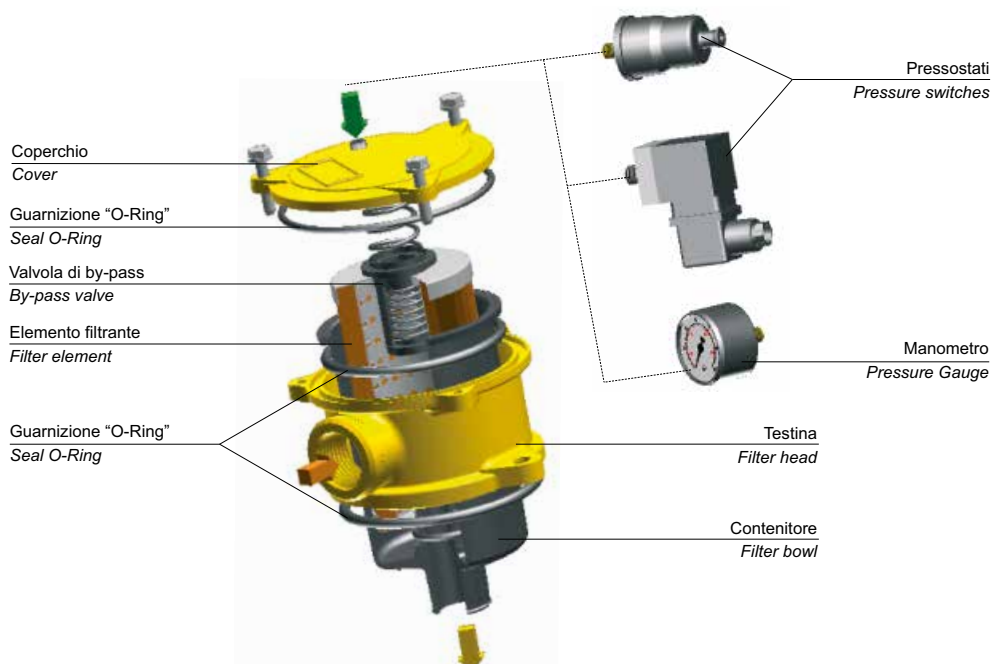

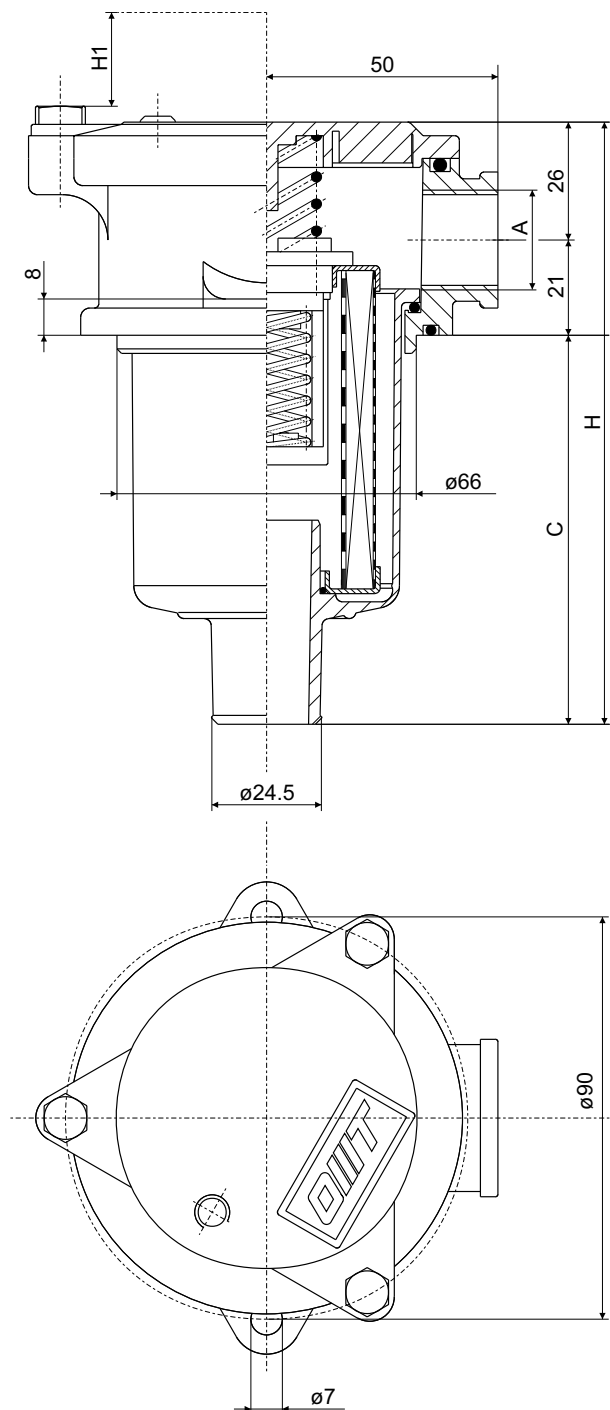

ATTACCHI CONNECTION PORTS

Tipo / Type	A
	1/2" BSP

LUNGHEZZE E PESO LENGTHS AND WEIGHT

Tipo / Type	C	H	H1	Peso (Kg) Weight (Kg)
1	85	132	110	0,400

FORATURA SERBATOIO TANK MOUNTING PATTERN

SERIE / SERIES 09

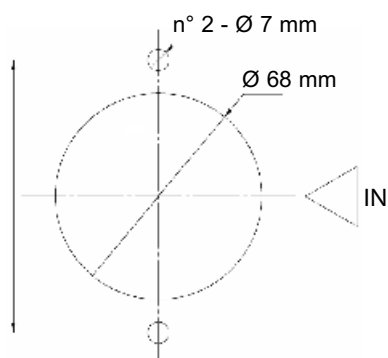

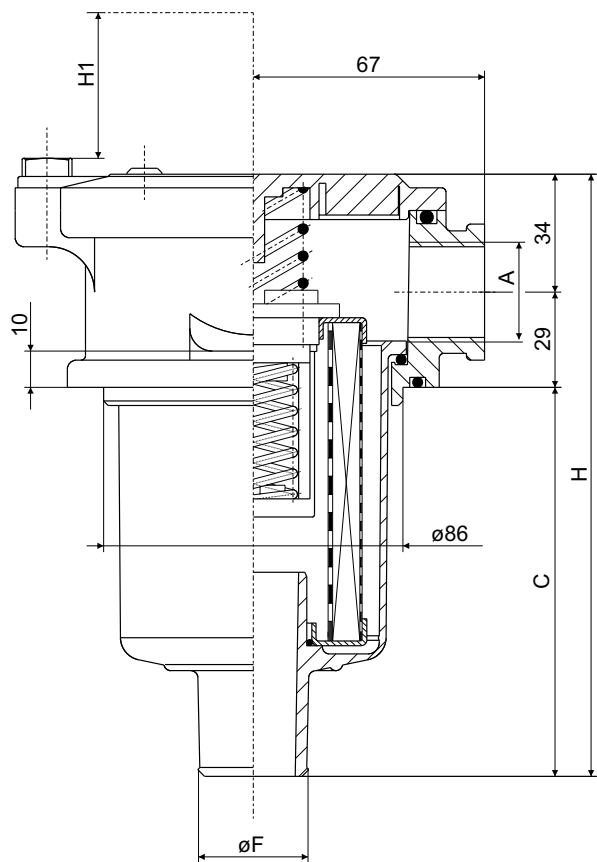

ATTACCHI
CONNECTION PORTS

Tipo / Type	A
1	1/2" BSP
2	3/4" BSP
2	1" BSP

LUNGHEZZE E PESO
LENGTHS AND WEIGHT

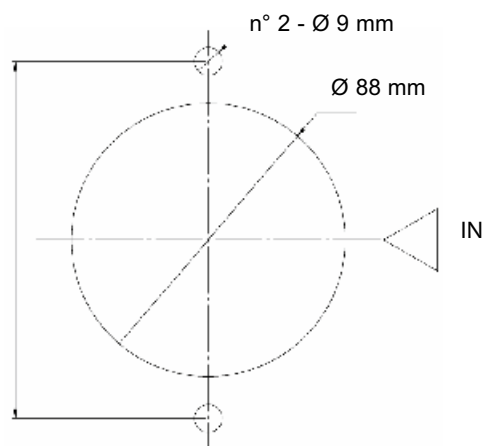
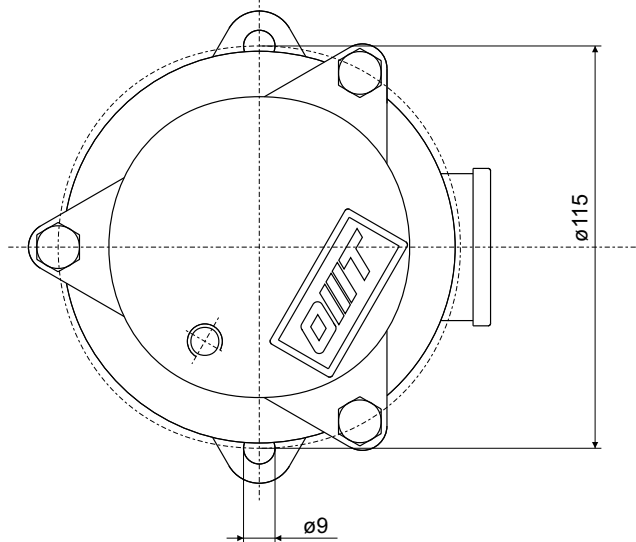
Tipo / Type	C	H	H1	ØF	Peso (Kg) Weight (Kg)
1	92	155	130	30	0,715
2	150	213	190	30	0,770
3	232	295	270	40	0,830

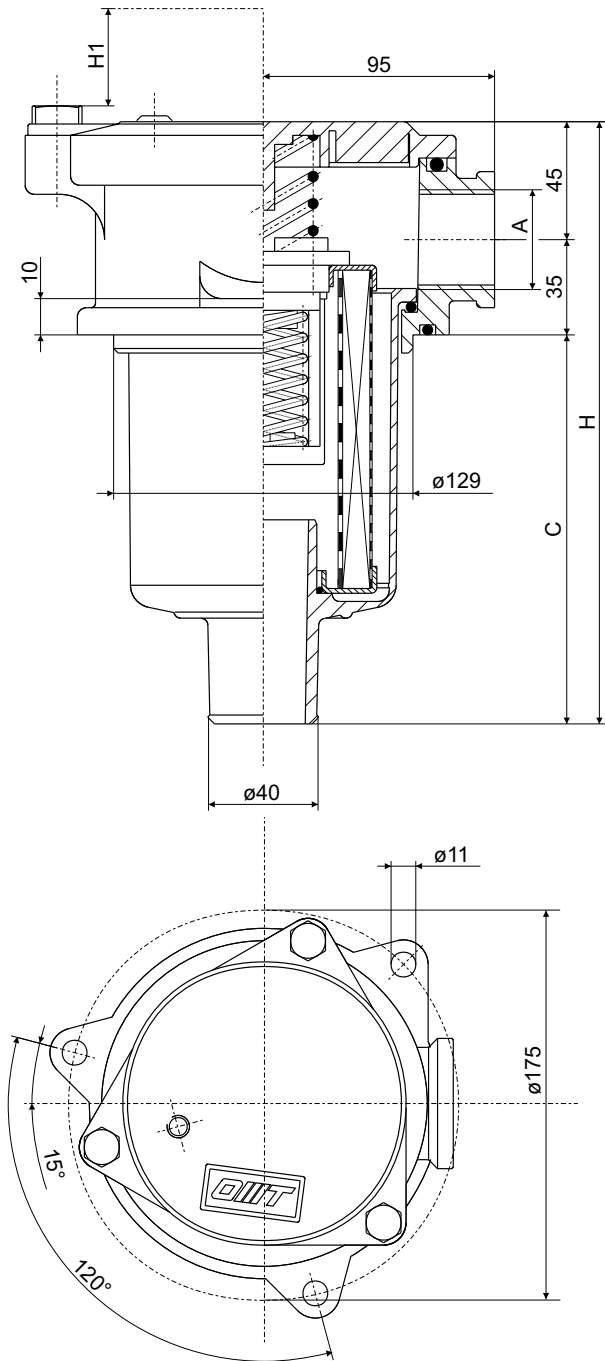
FORATURA SERBATOIO
TANK MOUNTING PATTERN
SERIE / SERIES 11



ATTACCHI CONNECTION PORTS

Tipo / Type	A
1	1" BSP 1 1/4" BSP

LUNGHEZZE E PESO LENGTHS AND WEIGHT

Tipo / Type	C	H	H1	Peso (Kg) Weight (Kg)
1	244	323	255	1,940

FORATURA SERBATOIO TANK MOUNTING PATTERN

SERIE / SERIES 17

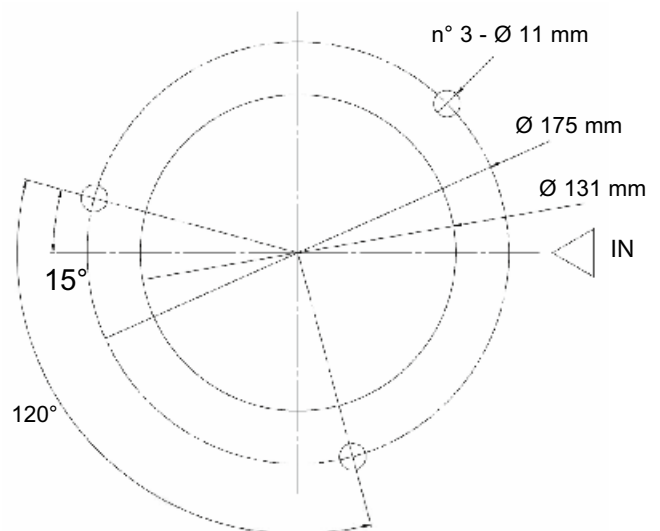

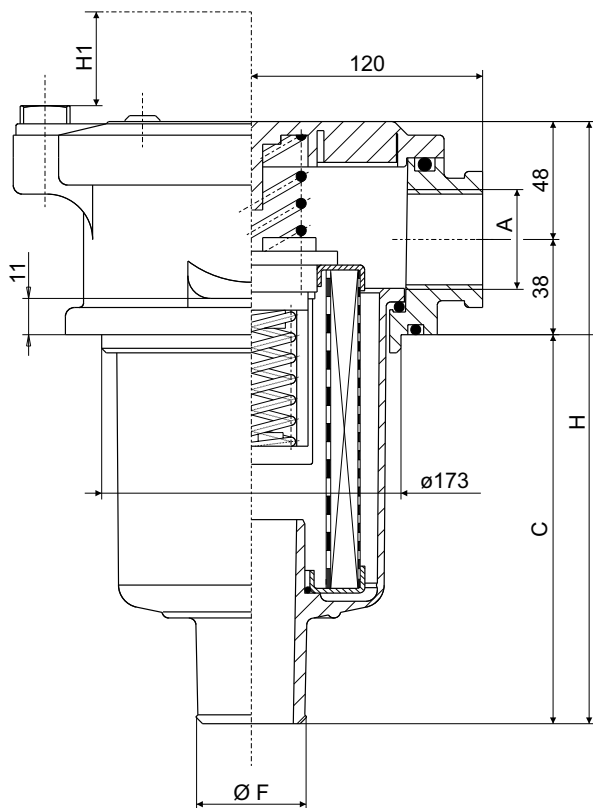

ATTACCHI CONNECTION PORTS

Tipo / Type	A
1	1 1/4" BSP
2	1 1/2" BSP
2	2" BSP

LUNGHEZZE E PESO LENGTHS AND WEIGHT

Tipo / Type	C	H	H1	ØF	Peso (Kg) Weight (Kg)
1	176	262	210	51	3,250
2	236	322	260	51	3,800
3	236	322	260	64	3,800
4	282	368	320	64	3,900

FORATURA SERBATOIO TANK MOUNTING PATTERN

SERIE / SERIES 22

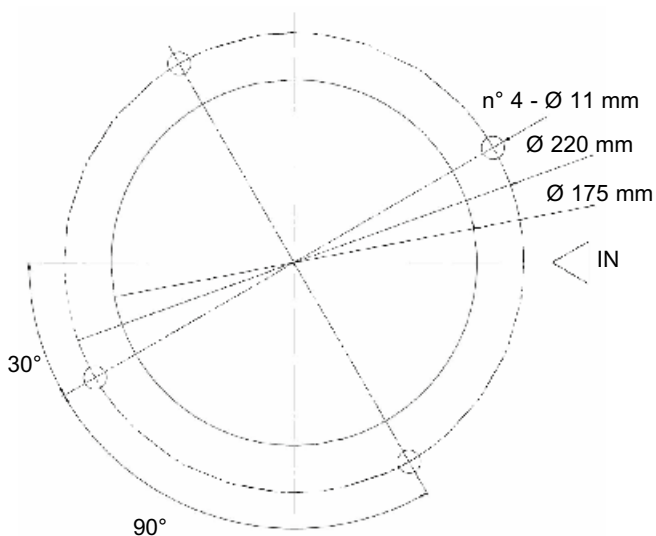
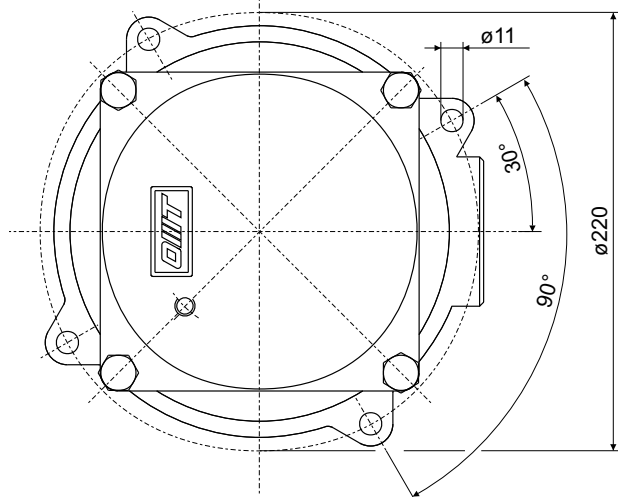

Il valore della caduta di pressione totale (Δp) si ottiene sommando, il valore Δp del corpo filtro e dell'elemento filtrante ad una data portata. Questo non deve idealmente superare 0.5 bar (7,3 psi) e non dovrebbe eccedere 1/3 del valore di taratura della valvola di by-pass.

La caduta di pressione dipende dalla viscosità dell'olio mediamente in maniera direttamente proporzionale.

The total Pressure Drop (Δp) value is obtained by adding the Δp values of filter housing and filter element at the given flow rate.

This ideally should not exceed 0,5 bar (7,3 psi) and should never exceed 1/3 of the set value of the by-pass valve.

The Pressure Drop is affected by the oil viscosity in a roughly proportional way.

OMTF serie/series 09

ΔP CORPI / ΔP HOUSINGS

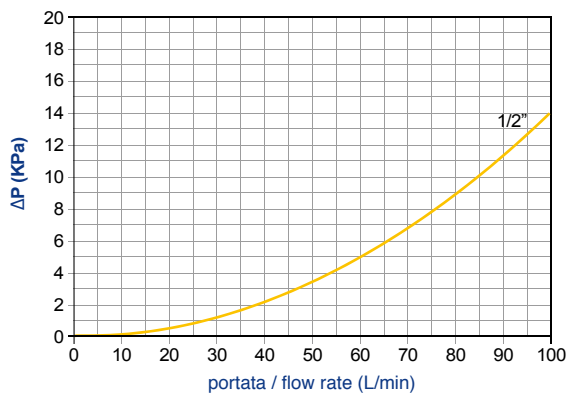

BY-PASS / BY-PASS

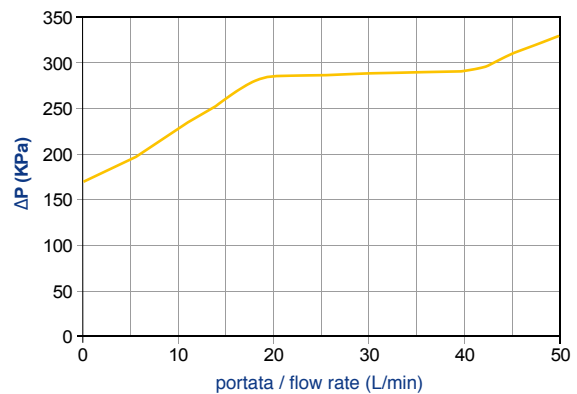

tipo CR09 1 series

ΔP ELEMENTI

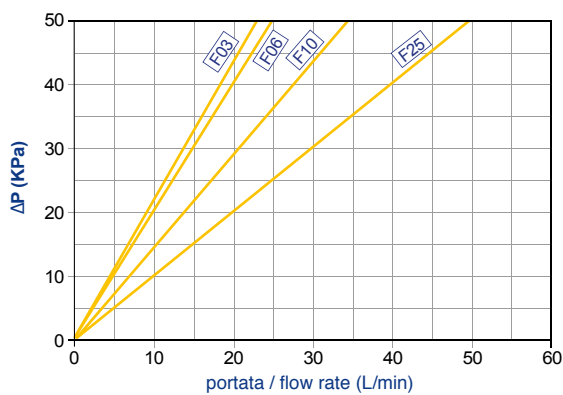

ΔP ELEMENTS

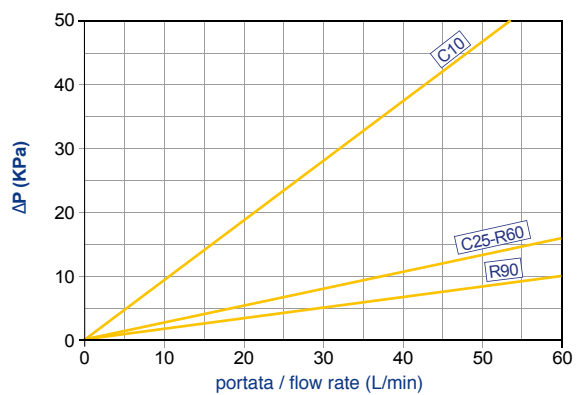

OMTF serie / series 11

ΔP CORPI / ΔP HOUSINGS

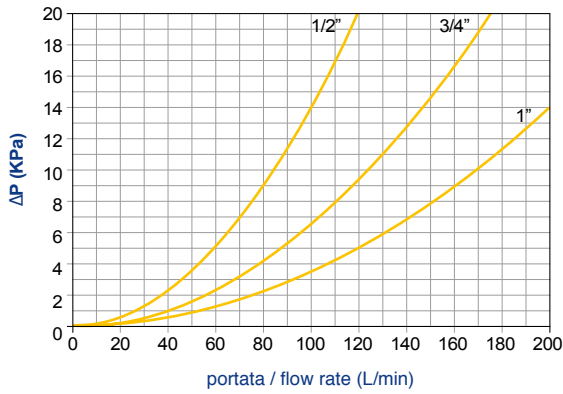

BY-PASS / BY-PASS

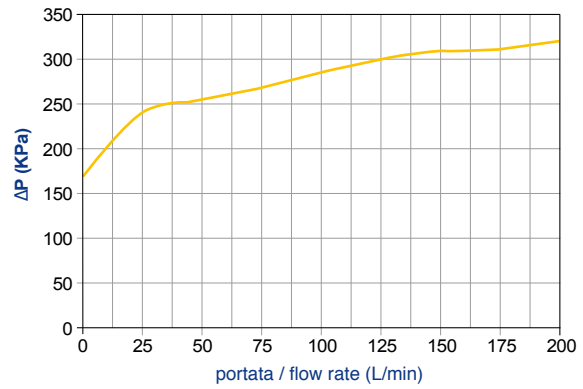

tipo CR11 1 series

ΔP ELEMENTI

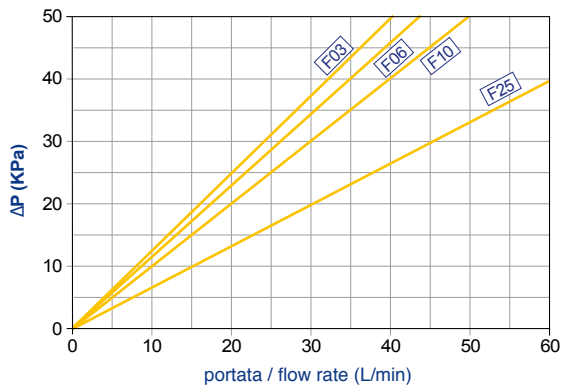

ΔP ELEMENTS

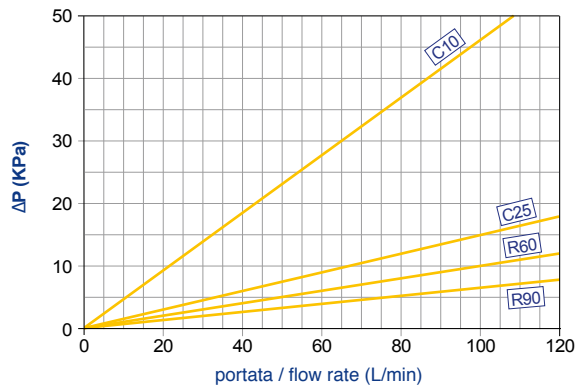

tipo CR11 2 series

ΔP ELEMENTI

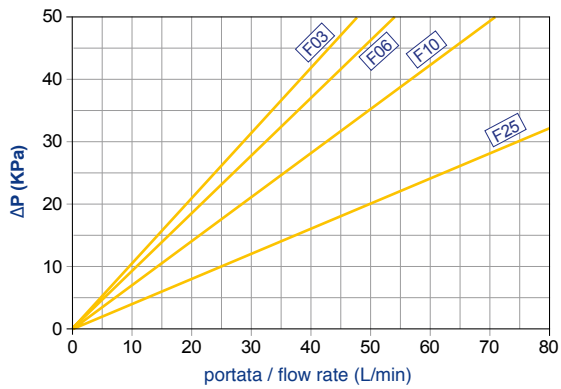

ΔP ELEMENTS

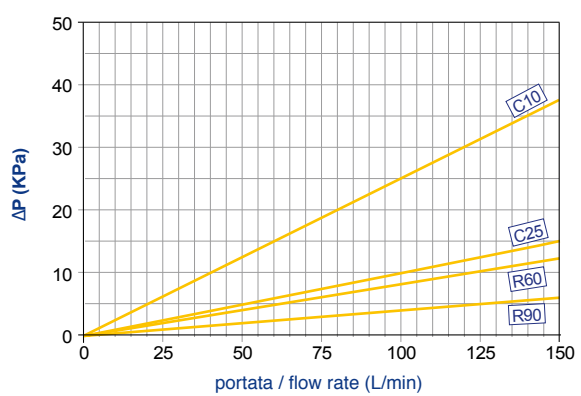

tipo CR11 3 series

ΔP ELEMENTI

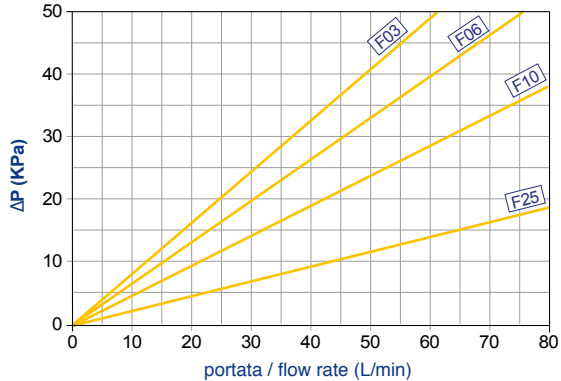

ΔP ELEMENTS

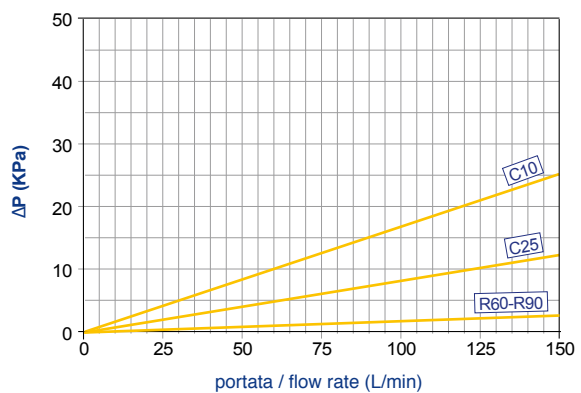

OMTF serie / series 17

ΔP CORPI / ΔP HOUSINGS

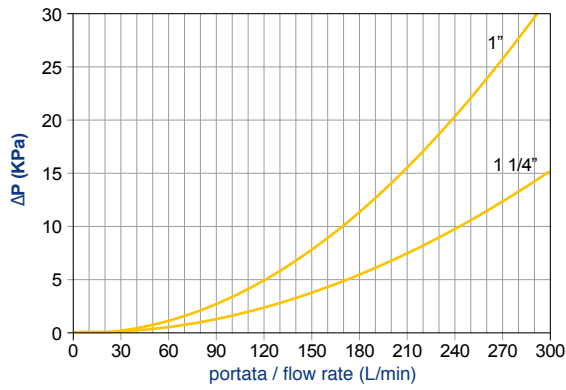

BY-PASS / BY-PASS

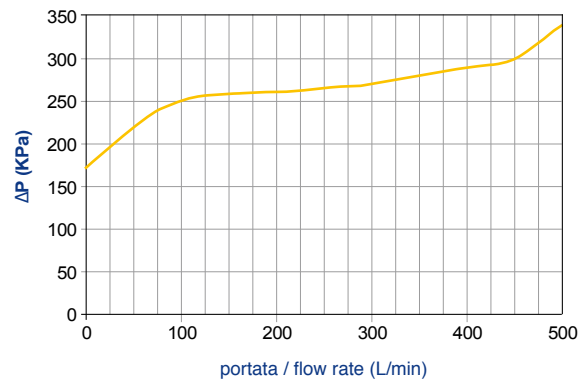

tipo CR17 1 series

ΔP ELEMENTI

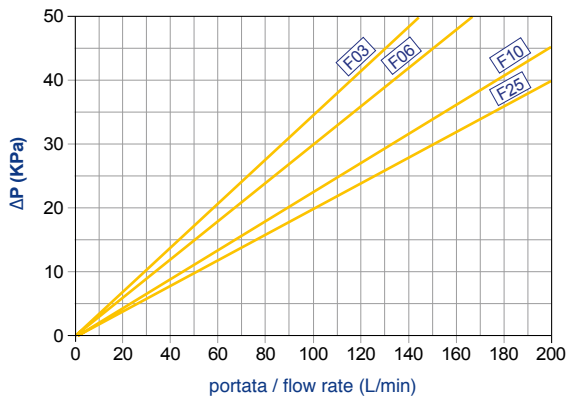

ΔP ELEMENTS

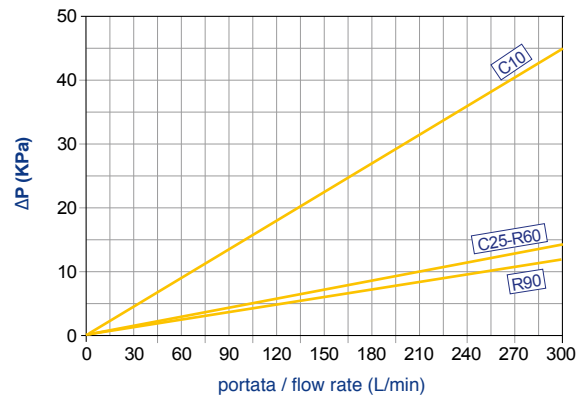

OMTF serie / series 22

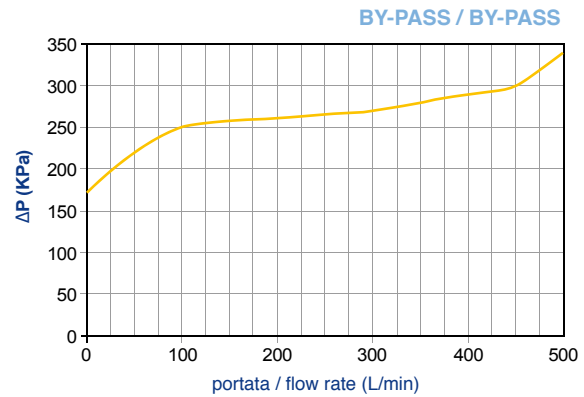
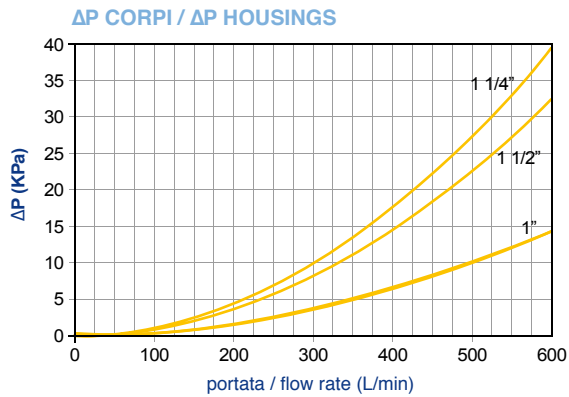

tipo CR22 1 series

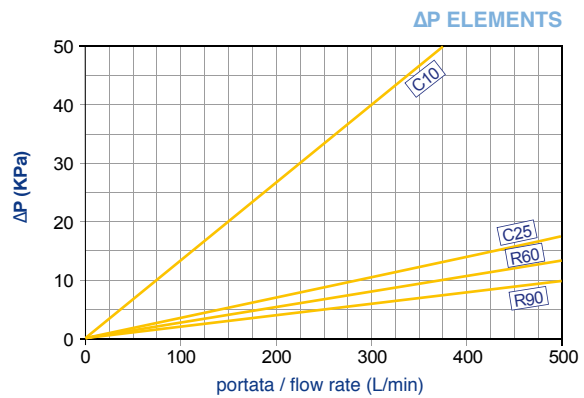
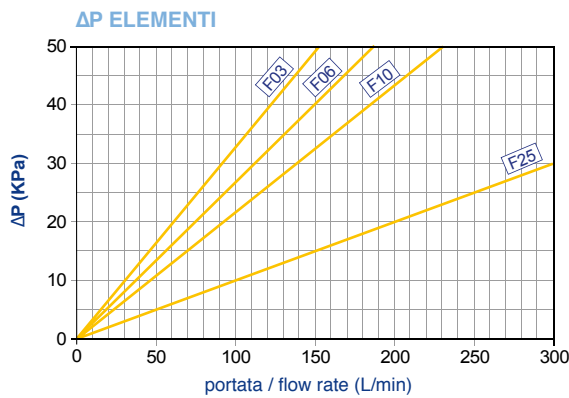

tipo CR22 2-3 series

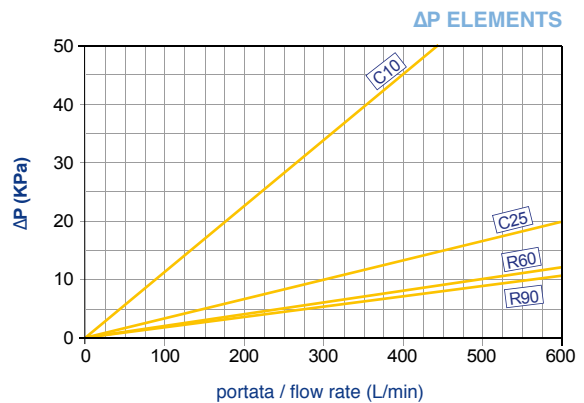
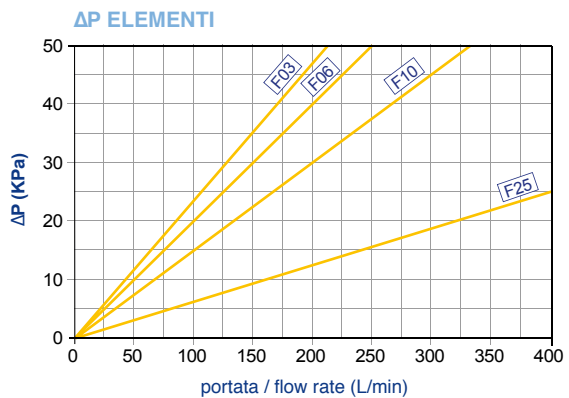

tipo CR22 4 series

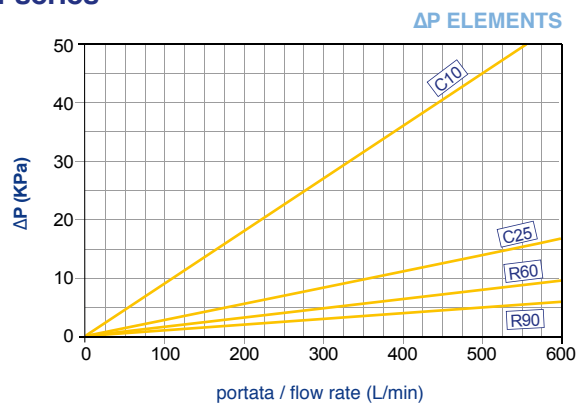
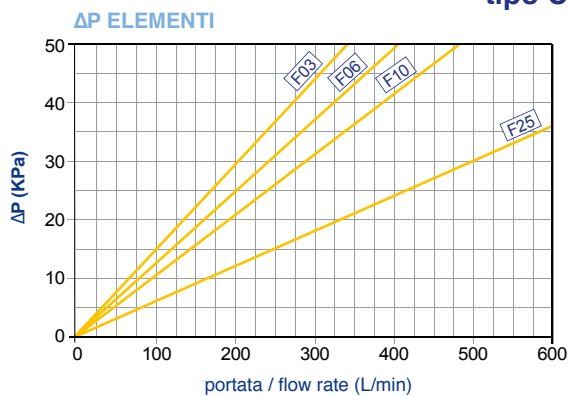

F10 - 001

Manometro
Pressure gauge

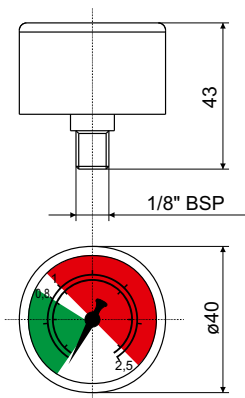

PV1

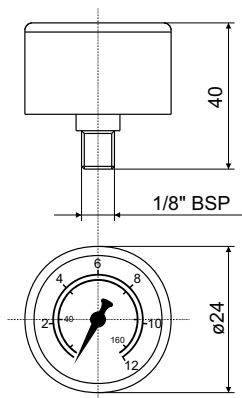

PE1 - PE2

Pressostato
con contatti N.A. o N.C.
Pressure switch
with contacts N.O. or N.C.

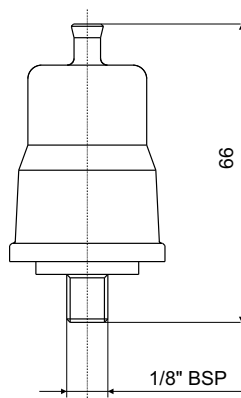

PE3

Pressostato
con contatti in scambio
Pressure switch
with changeover contacts

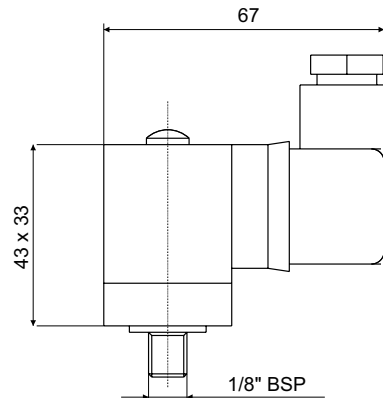

NB. La caduta di pressione (Δp) attraverso il filtro cresce durante l'utilizzo. L'elemento filtrante deve essere sostituito quando l'indicatore lo segnala e prima che Δp raggiunga il valore di taratura della valvola di by-pass. Accertarsi che l'indicatore non dia un falso allarme in caso di partenza a freddo (alta viscosità dovuta a bassa temperatura).

NB. The Pressure Drop (Δp) through the filter increases during the system operation. The cartridge must be replaced when the indicator shows and before the Δp reaches the by-pass value setting. In cold start conditions a false alarm can be caused by higher oil viscosity due to low temperature.

CARATTERISTICHE TECNICHE TECHNICAL DATA

Codice Part number	Descrizione Description	Scala taratura Setting	Contatti elettrici Electrical Contacts	Tipo Type
F10-001	visivo visual	0-2,5 bar	-	Puntuale On the spot
PV1	visivo visual	0-12 bar	-	
PE1	elettrico electrical	1,3 bar	N.A. / N.O.	
PE2			N.C.	
PE3			Scambio Changeover	

CARATTERISTICHE ELETTRICHE ELECTRICAL DATA

Codice Part number	Tensione max di alimen. (V) Max feeder voltage (V)	Carico resistivo (A) Resistive load (A)	Carico induttivo (A) Inductive load (A)	Protezione (completo) Protection (complete)
PE1	C.A. 48	0,5	0,2	IP 54
PE2	C.A. 48	0,5	0,2	IP 54
PE3	C.A. 250	3	2	IP 65 DIN40050

SIMBOLOGIA / SIMBOLOGY

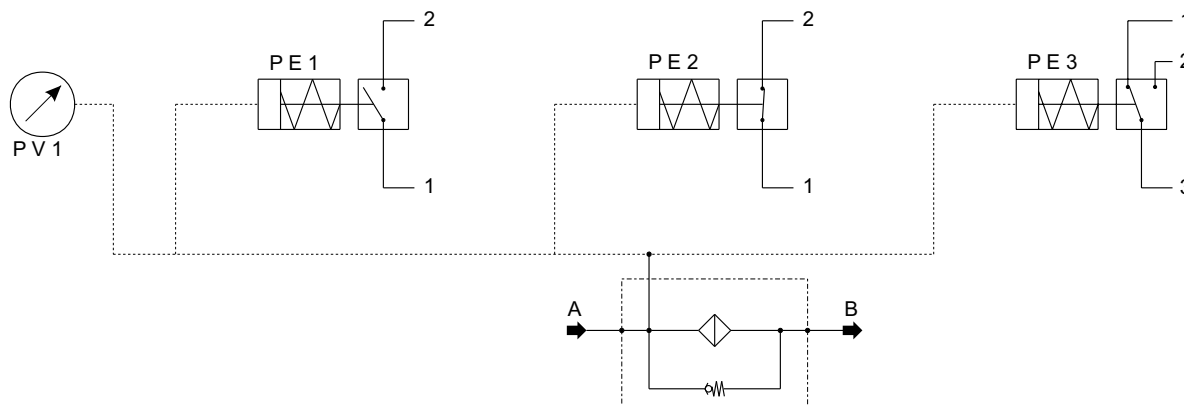

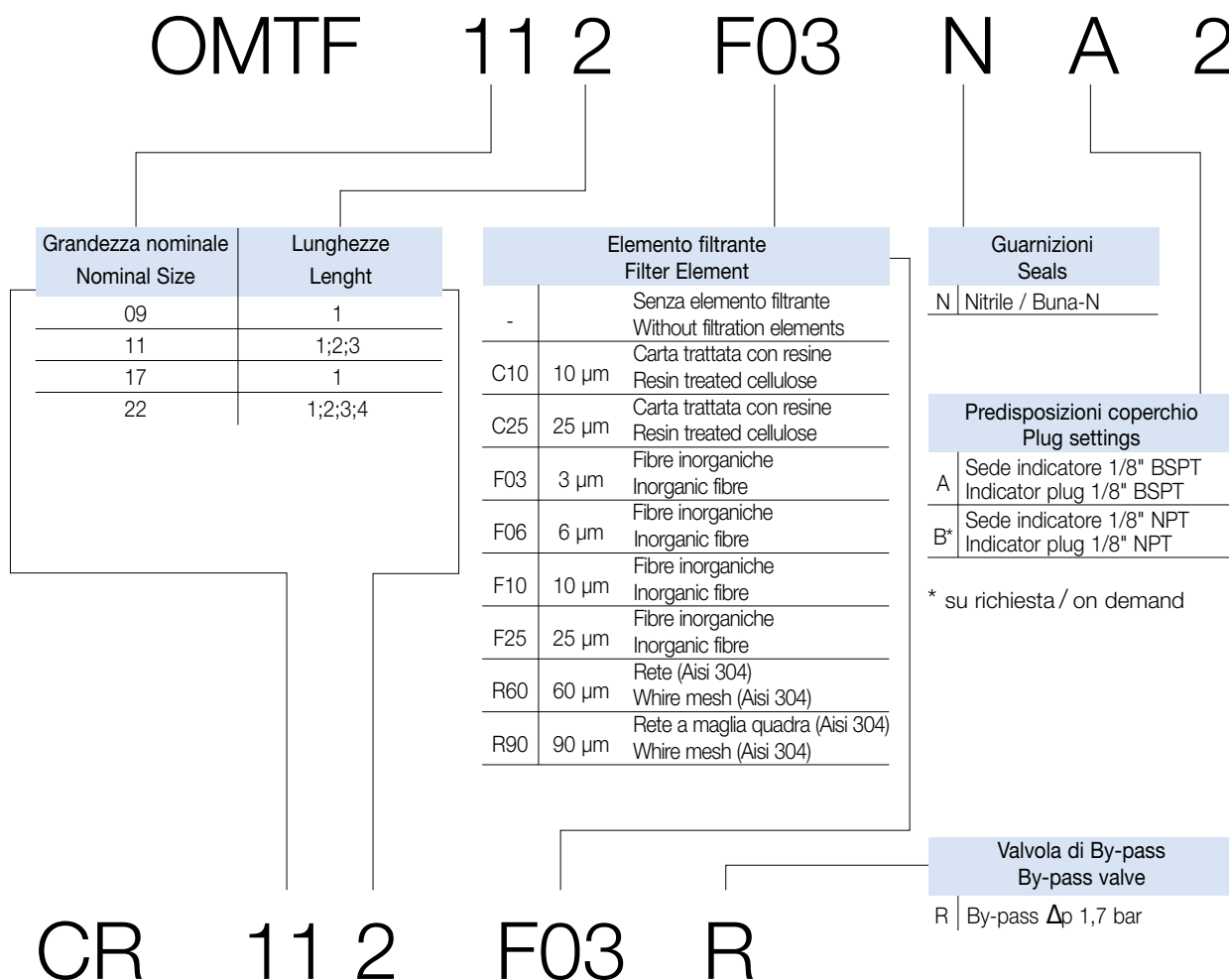

Codice per l'ordinazione dell'elemento filtrante di ricambio
Filter element code

ATTACCHI CONNECTION PORTS

A	OMTF09	OMTF11	OMTF17	OMTF22
-	1/2" BSP	1/2" BSP	1" BSP	1 1/4" BSP
1		3/4" BSP	1 1/4" BSP	1 1/2" BSP
2		1" BSP		2" BSP

CODICE KIT GUARNIZIONI SPARE SEAL KIT P/N

TIPO - TYPE	NBR - BUNA N
OMTF09	KIT - OMTF09
OMTF11	KIT - OMTF11
OMTF17	KIT - OMTF17
OMTF22	KIT - OMTF22

* Per l'ordinazione degli indicatori di intasamento, guardare pag.67

* See page 67 for information how to order clogging indicators