

HYDRAULIC GEAR
PUMPS AND
MOTORS

POLARIS[®]

INDEX

Section	Page
INTRODUCTION.....	3
INSTRUCTIONS	4
FEATURES.....	5
GEAR PUMPS PERFORMANCE CURVES.....	9
GEAR MOTORS PERFORMANCE CURVES	21
SINGLE UNITS DIMENSIONS.....	34
MULTIPLE PUMPS.....	39
MULTIPLE PUMPS DIMENSIONS.....	44
OUTBOARD BEARING OPTIONS	48
VERSION WITH OUTBOARD BEARING.....	49
DRIVE SHAFTS.....	52
MOUNTING FLANGES AND TABLE OF COMPATIBILITY.....	58
PORTS POSITION AND TYPE.....	70
PORTS SIZE	72
VALVE OPTIONS.....	76
HOW TO ORDER POLARIS SINGLE UNITS	78
HOW TO ORDER POLARIS MULTIPLE PUMPS.....	84
HOW TO ORDER POLARIS DOUBLE PUMPS DIFFERENT GROUPS	90

Replaces: 04/10.2020

05/04.2023

Modification from former edition.

INTRODUCTION

“POLARIS” more than fifty years of Casappa experience in design and production of hydraulic components, characterized by large investments in research and development in order to propose new and personalized solutions to the market.

Our use of CAD 3D in the development of this generation permit us the 3D modelling and the virtual simulation of the behaviour of the components inserted in the hydraulic circuit. This means that the process will take less time and the quality of the products is better.

Polaris pumps and motors are basically composed of a gear housing in aluminium alloy, two gear wheels supported by sleeve bearings and two end plates, the front and the rear cover, either in aluminium or in cast iron with excellent mechanical characteristics.

Our success is based largely on the quality of our product. This guaranties the consistencies of the efficiencies and low level of noise emission during the life of our products.

DISPLACEMENTS

From 1,07 cm³/rev (0.07 in³/rev)

To 91,10 cm³/rev (5.56 in³/rev)

PRESSURE

Max. constant operating pressure 260 bar (3770 psi)

Max. system pressure (relief valve setting) 280 bar (4060 psi)

Max. peak of pressure 300 bar (4350 psi)

SPEED

Max. 4000 min⁻¹

- Available in groups 10, 20 and 30.
- Drive shafts, mounting flanges and ports according to the international standards.
- Combination of multiple pumps in standard version, common inlet and separated stages.
- Integrated outboard bearings for heavy duty application.
- Many types of built-in valves.

TYPICAL APPLICATIONS

- Building & Construction
- Material Handling
- Agriculture
- Forestry
- Turf care & Mowers
- Fan Drive

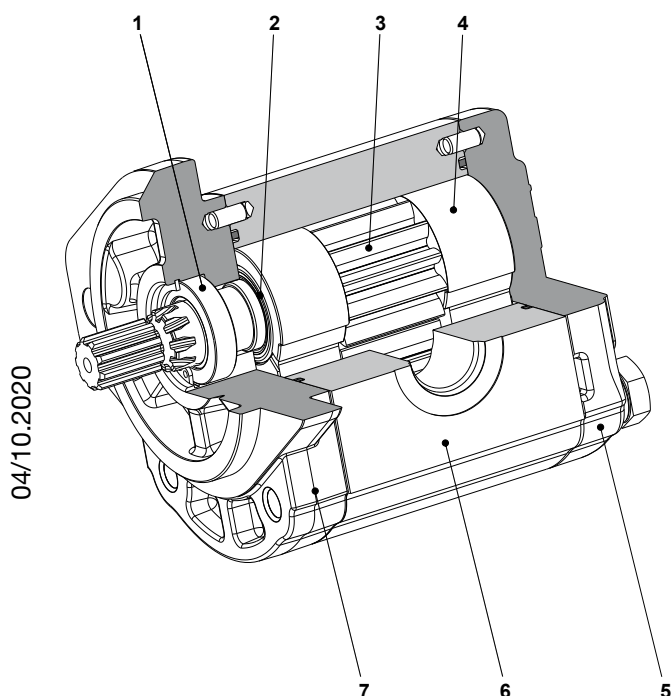

1	Shaft seal
2	Seal
3	Gear
4	Thrust plate
5	Rear cover
6	Body
7	Mounting flange

INSTRUCTIONS

INSTALLATION

Pump

The direction of rotation of single-rotation pumps must be the same as that of the drive shaft. Check that the coupling flange correctly aligns the transmission shaft and the pump shaft. Flexible couplings should be used (never rigid fittings) which will not generate an axial or radial load on the pump shaft.

Motor

The direction of rotation of single-rotation motors must match circuit connections. Check that the coupling flange correctly aligns the transmission shaft and the motor shaft. Flexible couplings should be used (never rigid fittings) which will not generate an axial or radial load on the motor shaft.

TANK

Tank capacity must be sufficient for the system's operating conditions (~ 3 times the amount of oil in circulation) to avoid overheating of the fluid. A heat exchanger should be installed if necessary. The intake and return lines in the tank must be spaced apart (by inserting a vertical divider) to prevent the return-line oil from being taken up again immediately.

LINES

The lines must have a major diameter which is at least as large as the diameter of pump or motor ports, and must be perfectly sealed. To reduce loss of power, the lines should be as short as possible, reducing the sources of hydraulic resistance (elbow, throttling, gate valves, etc.) to a minimum. A length of flexible tubing is recommended to reduce the transmission of vibrations. All return lines must end below the minimum oil level, to prevent foaming. Before connecting the lines, remove any plugs and make sure that the lines are perfectly clean.

HYDRAULIC FLUID

Use hydraulic fluid conforming to viscosity data as specified in the first pages of the catalogue. Avoid using mixtures of different oils which could result in decomposition and reduction of the oil's lubricating power.

FILTERS

We recommend filtering the entire system flow. Filters on suction and return line must be fitted in according to the contamination class as indicated in the first pages of the catalogue. Casappa recommends to use its own production filters:



STORAGE

The storage must be in a dry environment.

Max storage time in ideal conditions is 24 months.

The ideal storage temperature is between 5 °C (41 °F) and 20 °C (68 °F). No problem in case of temperature between -40 °C (-40 °F) and 50 °C (122 °F). Below -40 °C (-40 °F) please consult our pre-sales department.

STARTING UP

Check that all circuit connections are tight and that the entire system is completely clean. Insert the oil in the tank, using a filter. Bleed the circuit to assist in filling. Set the pressure relief valves to the lowest possible setting. Turn on the system for a few moments at minimum speed, then bleed the circuit again and check the level of oil in the tank.

If the difference between pump or motor temperature and fluid temperature exceeds 10 °C (18 °F), rapidly switch the system on and off to heat it up gradually. Then gradually increase the pressure and speed of rotation until the pre-set operating levels as specified in the catalogue are attained.

COLD START

Cold start is meant short term and low idle. During cold start of the machine the following limits can be applied:

Minimum inlet pressure	0,5 bar abs. (7 psi)
Outlet pressure (pumps) Inlet pressure (motors)	≤ 50 bar (725 psi)
Max drain pressure / Max back pressure for single rotation motors	+ 50% of standard values
Speed	≤ 1500 min ⁻¹
Minimum temperature	-40 °C (-40 °F)
Max oil viscosity	2000 mm ² /s (cSt) [9100 SSU]

If the ambient temperature is lower than -20 °C (-4 °F) the system speed and pressure must be limited until the hydraulic oil temperature exceeds -20 °C (-4 °F).

PERIODICAL CHECKS - MAINTENANCE

Keep the outside surface clean especially in the area of the drive shaft seal. In fact, abrasive powder can accelerate wear on the seal and cause leakage. Replace filters regularly to keep the fluid clean. The oil level must be checked and oil replaced periodically depending on the system's operating conditions.

Replaces: 04/10.2020

 05/04.2023

FEATURES

Construction	External gear pumps and motors 3-piece construction
Mounting	EUROPEAN - SAE - GERMAN standard flanges
Ports	Threaded or flanged
Direction of rotation (looking on drive shaft)	Anti-clockwise (S) - clockwise (D) - reversible external drain (R - L) reversible internal drain (B)
Inlet pressure range for pumps	0,7 ÷ 3 bar abs. (10 ÷ 44 psi) If p > 1,5 bar abs. (22 psi) specific shaft sealing have to be applied. Please consult our pre-sales department.
Max back pressure for single rotation motors	5 bar (73 psi) continuous @ min. speed 350 min ⁻¹ 1 bar (14.5 psi) continuous @ max. speed (see page 7)
Max drain line pressure on reversible rotation motors	5 bar (73 psi) continuous @ min. speed 350 min ⁻¹ 1 bar (14.5 psi) continuous @ max. speed (see page 7)
Max back pressure on in series motors	150 bar (2175 psi)
Fluid temperature range	See table (1)
Fluid	Mineral oil based hydraulic fluids to ISO/DIN. Please contact us for other fluids
Viscosity range	From 12 to 100 mm ² /s (cSt) [60 to 456 SSU] recommended Up to 750 mm ² /s (cSt) [3410 SSU] permitted
Filtering requirement and recommended fluid contamination	See table (2) page 6

Tab. 1

Type	Fluid composition	Max pressure bar (psi)	Max speed min ⁻¹	Temperature - °C (°F)			Seals (●)	Shaft seals option (◆)
				Min	Max continuous	Max peak		
ISO/DIN	Mineral oil based hydraulic fluid to ISO/DIN	See page 7	See page 7	-25 (-13)	80 (176)	100 (212)	N	D C1
				-25 (-13)	110 (230)	125 (257)	V	
				-25 (-13)	110 (230)	125 (257)	T-PV	

(●) **N** = Buna NBR (standard) - **V** = Viton-FKM - **T-PV** = Hydrogenated buna HNBR seals with Viton-FKM shaft seals (only for PLP20)

D (◆) shaft seals with wiper seal

C1 (◆) High pressure special shaft seal

04/10.2020

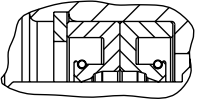
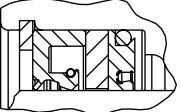
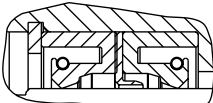
Single rotation pumps	Max drain line pressure: 0,5 bar (7 psi)		Max drain line pressure: 10 bar (145 psi) @ 350 min ⁻¹	
Single rotation motors Reversible rotation pumps and motors	Max drain line pressure: 5 bar (73 psi) @ 350 min ⁻¹			

FEATURES

Filtration

Casappa recommends to use its own production filters:

Tab. 2

Working pressure bar (psi)	$\Delta p < 140$ (2030)	$140 < \Delta p < 210$ (2030) (3045)	$\Delta p > 210$ (3045)
Contamination class NAS 1638	10	9	8
Contamination class ISO 4406	21/19/16	20/18/15	19/17/14
Achieved with filter $\beta_{10}(c) \geq 75$ according to ISO 16889	-	10 μm	10 μm
Achieved with filter $\beta_{25}(c) \geq 200$ according to ISO 16889	25 μm	-	-



DEFINITION OF ROTATION DIRECTION LOOKING AT THE DRIVE SHAFT

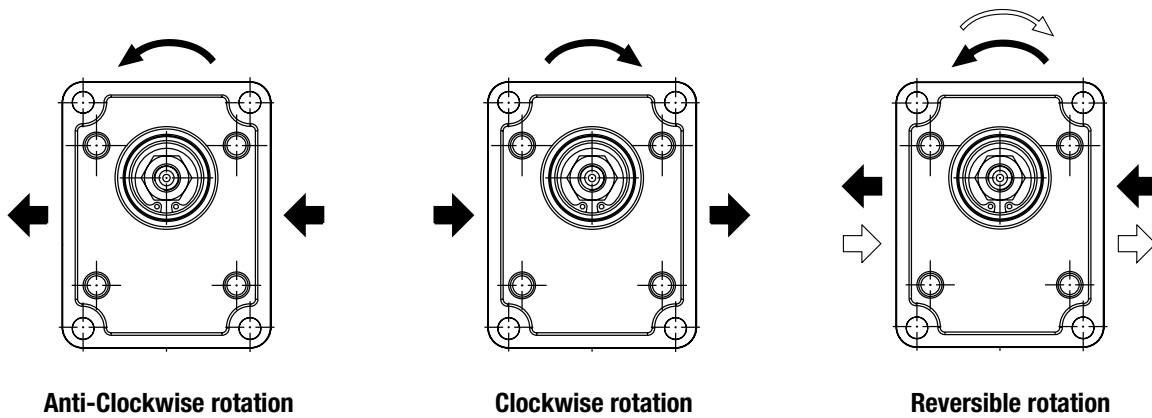

GENERAL NOTES

Available with different inlet and outlet ports.
Please contact us for more information.

PRESSURE DEFINITION

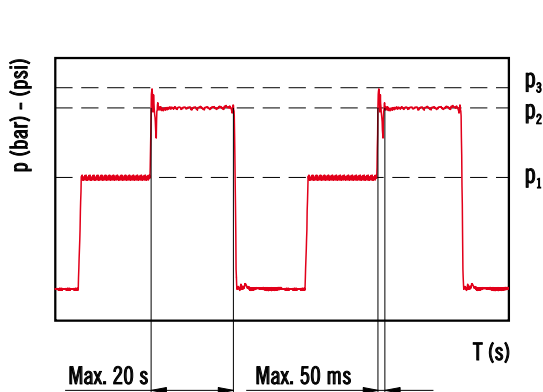

- p_1 Constant operating pressure
- p_2 System pressure (relief valve setting)
- p_3 Peak of pressure

The peak of pressure is the max pressure allowed and it corresponds to the overshoot of the relief valve.

Please note that both relief valve setting and overshoot must be lower than their limits.
If the relief setting is compliant but the overshoot is higher than the limit, the relief setting must be decreased until the overshoot is compliant to Casappa limit.

Please contact us for high frequency applications.

04/10.2020

FEATURES

Series	Pump type PLP Motor type PLM	Displacement cm ³ /rev (in ³ /rev)	Max. pressure			Max. speed	Min. speed min ⁻¹
			P ₁	P ₂	P ₃		
			bar (psi)				
POLARIS 10	PL. 10•1	1,07 (0.07)	260 (3770)	280 (4060)	290 (4205)	4000	650
	PL. 10•1,5	1,60 (0.10)	260 (3770)	280 (4060)	290 (4205)	4000	650
	PL. 10•2	2,13 (0.13)	260 (3770)	280 (4060)	290 (4205)	4000	650
	PL. 10•2,5	2,67 (0.16)	260 (3770)	280 (4060)	290 (4205)	4000	650
	PL. 10•3,15	3,34 (0.20)	260 (3770)	280 (4060)	290 (4205)	4000	650
	PL. 10•4	4,27 (0.26)	250 (3625)	270 (3915)	280 (4060)	4000	650
	PL. 10•5	5,34 (0.33)	250 (3625)	270 (3915)	280 (4060)	4000	650
	PL. 10•5,8	6,20 (0.38)	230 (3335)	250 (3625)	260 (3770)	3500	650
	PL. 10•6,3	6,67 (0.41)	230 (3335)	250 (3625)	260 (3770)	3500	650
	PL. 10•8	8,51 (0.52)	180 (2610)	200 (2900)	210 (3045)	3500	650
PL. 10•10	10,67 (0.65)	140 (2030)	160 (2320)	170 (2465)	3500	650	
POLARIS 20	PL. 20•4	4,95 (0.30)	250 (3625)	280 (4060)	300 (4350)	4000	600
	PL. 20•6,3	6,61 (0.40)	250 (3625)	280 (4060)	300 (4350)	4000	600
	PL. 20•7,2	7,29 (0.44)	250 (3625)	280 (4060)	300 (4350)	4000	600
	PL. 20•8	8,26 (0.50)	250 (3625)	280 (4060)	300 (4350)	3500	600
	PL. 20•9	9,17 (0.56)	250 (3625)	280 (4060)	300 (4350)	3500	600
	PL. 20•10,5	10,9 (0.66)	250 (3625)	280 (4060)	300 (4350)	3500	600
	PL. 20•11,2	11,23 (0.69)	250 (3625)	280 (4060)	300 (4350)	3500	600
	PL. 20•14	14,53 (0.89)	250 (3625)	280 (4060)	300 (4350)	3500	500
	PL. 20•16	16,85 (1.03)	250 (3625)	280 (4060)	300 (4350)	3000	500
	PL. 20•19	19,09 (1.16)	200 (2900)	220 (3190)	240 (3480)	3000	500
	PL. 20•20	21,14 (1.29)	200 (2900)	220 (3190)	240 (3480)	3000	500
	PL. 20•24,5	24,84 (1.52)	170 (2465)	190 (2755)	210 (3045)	2500	500
	PL. 20•25	26,42 (1.61)	170 (2465)	190 (2755)	210 (3045)	2500	500
	PL. 20•27,8	28,21 (1.72)	130 (1885)	150 (2175)	170 (2465)	2000	500
PL. 20•31,5	33,03 (2.01)	130 (1885)	150 (2175)	170 (2465)	2000	500	
POLARIS 30	PL. 30•22	21,99 (1.34)	250 (3625)	270 (3915)	280 (4060)	3000	350
	PL. 30•27	26,70 (1.63)	250 (3625)	270 (3915)	280 (4060)	3000	350
	PL. 30•34	34,55 (2.11)	240 (3480)	260 (3770)	270 (3915)	3000	350
	PL. 30•38	39,27 (2.40)	240 (3480)	260 (3770)	270 (3915)	3000	350
	PL. 30•43	43,98 (2.68)	230 (3335)	250 (3625)	260 (3770)	3000	350
	PL. 30•51	51,83 (3.16)	210 (3045)	230 (3335)	240 (3480)	2500	350
	PL. 30•61	61,26 (3.74)	190 (2755)	210 (3045)	220 (3190)	2500	350
	PL. 30•73	73,82 (4.50)	170 (2465)	190 (2755)	200 (2900)	2500	350
	PL. 30•82	81,68 (4.98)	160 (2320)	170 (2465)	180 (2610)	2200	350
PL. 30•90	91,10 (5.56)	150 (2175)	160 (2320)	170 (2465)	2200	350	

Pressure values in the table refer to side ports unidirectional pumps and motors.

For reversible pumps and motors, max pressures are 250 bar (3600 psi) excepted those with lower pressure values.

Please contact us for different working conditions.

04/10.2020

GENERAL DATA PUMPS AND MOTORS

Q	l/min (US gpm)	Flow
M	Nm (lbf in)	Torque
P	kW (HP)	Power
V	cm ³ /rev (in ³ /rev)	Displacement
n	min ⁻¹	Speed
Δp	bar (psi)	Pressure
$\eta_v = \eta_v(V, \Delta p, n)$		Volumetric efficiency
$\eta_{hm} = \eta_{hm}(V, \Delta p, n)$		Hydro-mechanical efficiency
$\eta_t = \eta_v \cdot \eta_{hm}$		Overall efficiency

○

Replaces: 03/02.2012

DESIGN CALCULATIONS FOR PUMP

$$Q = Q_{\text{theor.}} \cdot \eta_v \quad [\text{l/min}]$$

$$Q_{\text{theor.}} = \frac{V \cdot n}{1000} \quad [\text{l/min}]$$

$$M = \frac{M_{\text{theor.}}}{\eta_{hm}} \quad [\text{Nm}]$$

$$M_{\text{theor.}} = \frac{\Delta p \cdot V}{62,83} \quad [\text{Nm}]$$

$$P_{\text{in}} = \frac{P_{\text{out}}}{\eta_t} \quad [\text{kW}]$$

$$P_{\text{out}} = \frac{\Delta p \cdot Q}{600} \quad [\text{kW}]$$

DESIGN CALCULATIONS FOR MOTOR

$$Q = \frac{Q_{\text{theor.}}}{\eta_v} \quad [\text{l/min}]$$

$$Q_{\text{theor.}} = \frac{V \cdot n}{1000} \quad [\text{l/min}]$$

$$M = M_{\text{theor.}} \cdot \eta_{hm} \quad [\text{Nm}]$$

$$M_{\text{theor.}} = \frac{\Delta p \cdot V}{62,83} \quad [\text{Nm}]$$

$$P_{\text{in}} = \frac{\Delta p \cdot Q}{600} \quad [\text{kW}]$$

$$P_{\text{out}} = P_{\text{in}} \cdot \eta_t \quad [\text{kW}]$$

NOTES

Diagrams providing approximate selection data will be found on subsequent pages.

○ 05/04.2023

PLP 10

POLARIS 10 GEAR PUMPS PERFORMANCE CURVES

PLP 10

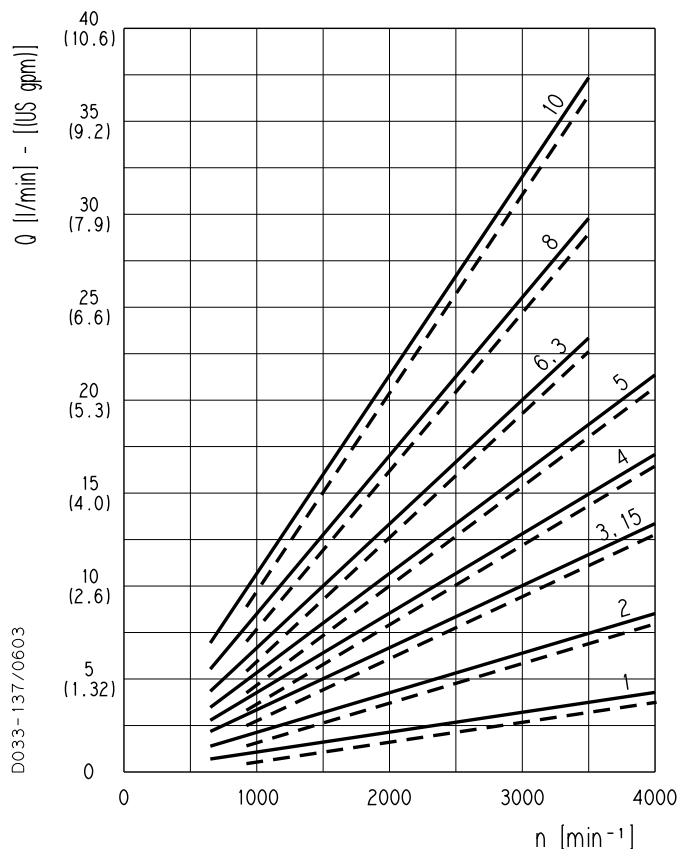

Each curve has been obtained at 50 °C (122 °F), using oil with viscosity 46 cSt (210 SSU) at 40 °C (104 °F) and at these pressures.

PLP 10•1 — 20 bar (290 psi)
 - - - 260 bar (3770 psi)

PLP 10•2 — 20 bar (290 psi)
 - - - 260 bar (3770 psi)

PLP 10•3,15 — 20 bar (290 psi)
 - - - 260 bar (3770 psi)

PLP 10•4 — 20 bar (290 psi)
 - - - 250 bar (3625 psi)

PLP 10•5 — 20 bar (290 psi)
 - - - 250 bar (3625 psi)

PLP 10•6,3 — 20 bar (290 psi)
 - - - 230 bar (3335 psi)

PLP 10•8 — 20 bar (290 psi)
 - - - 180 bar (2610 psi)

PLP 10•10 — 20 bar (290 psi)
 - - - 140 bar (2030 psi)

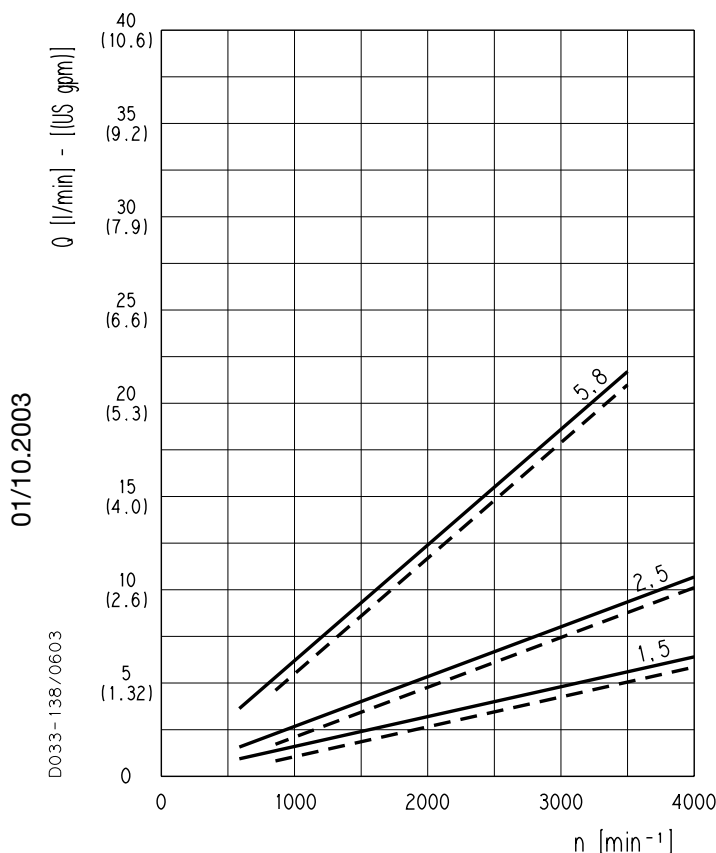

PLP 10•1,5 — 20 bar (290 psi)
 - - - 260 bar (3770 psi)

PLP 10•2,5 — 20 bar (290 psi)
 - - - 260 bar (3770 psi)

PLP 10•5,8 — 20 bar (290 psi)
 - - - 230 bar (3335 psi)

01/10.2003

D033-138/0603

PLP 10

POLARIS 10 GEAR PUMPS PERFORMANCE CURVES

PLP 10•1

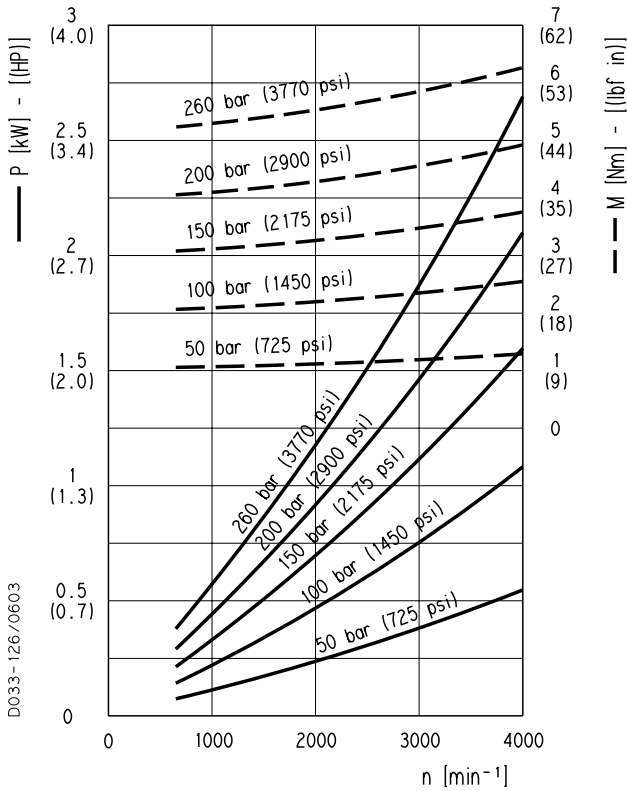

PLP 10•1,5

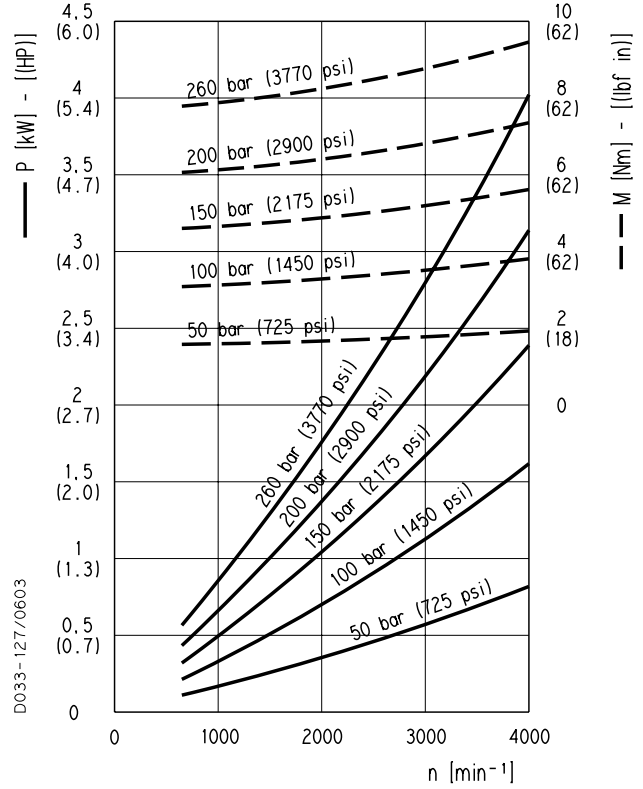

PLP 10•2

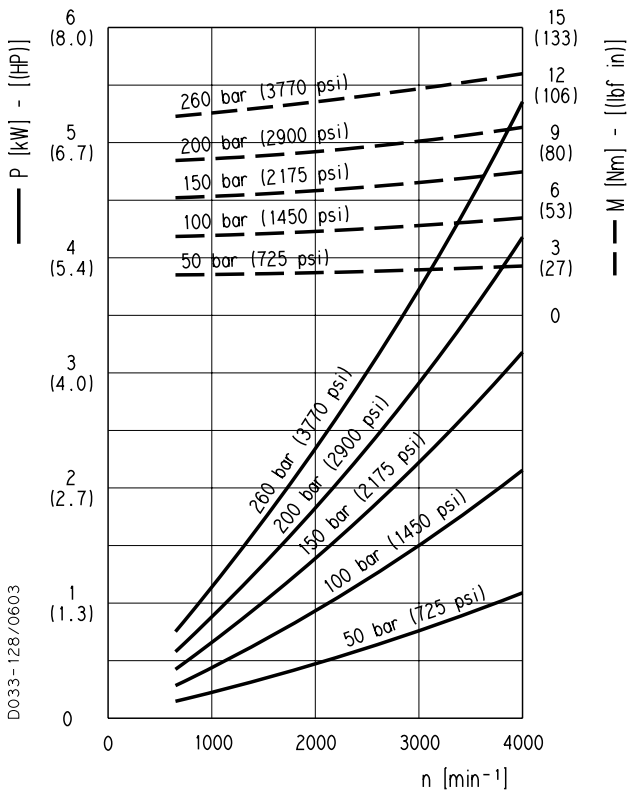

PLP 10•2,5

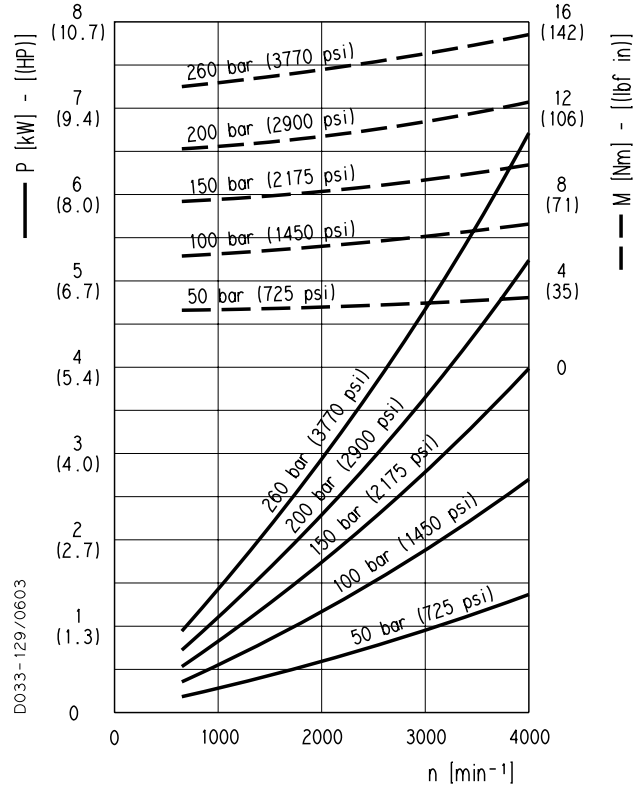

01/10.2003

PLP 10

POLARIS 10 GEAR PUMPS PERFORMANCE CURVES

PLP 10•3,15

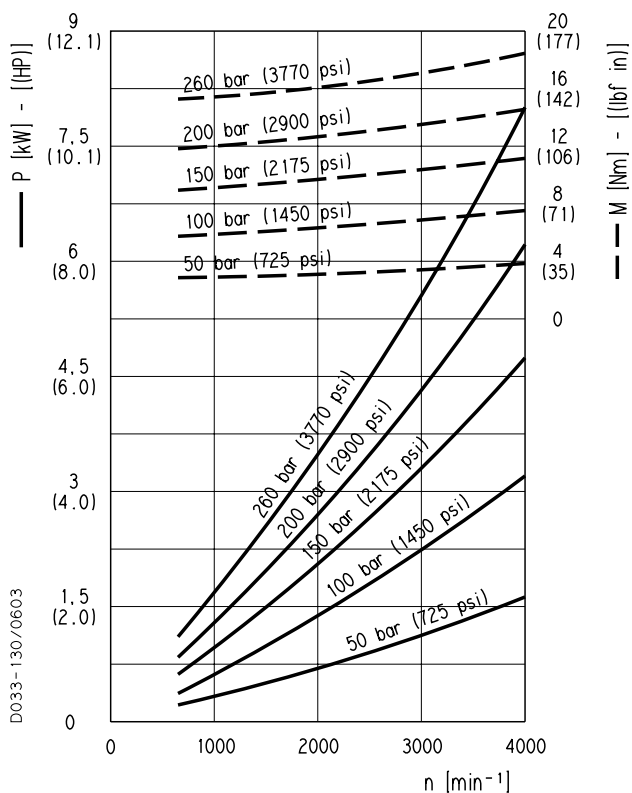

PLP 10•4

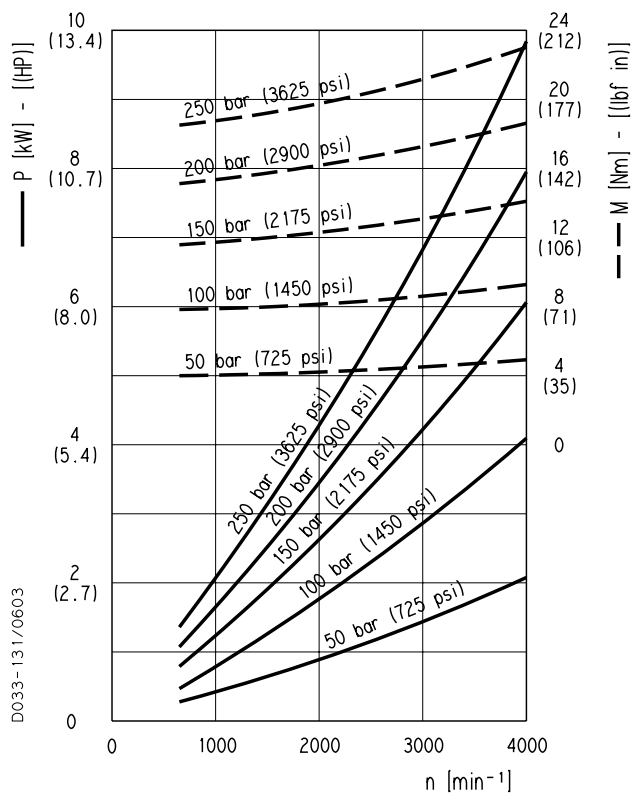

PLP 10•5

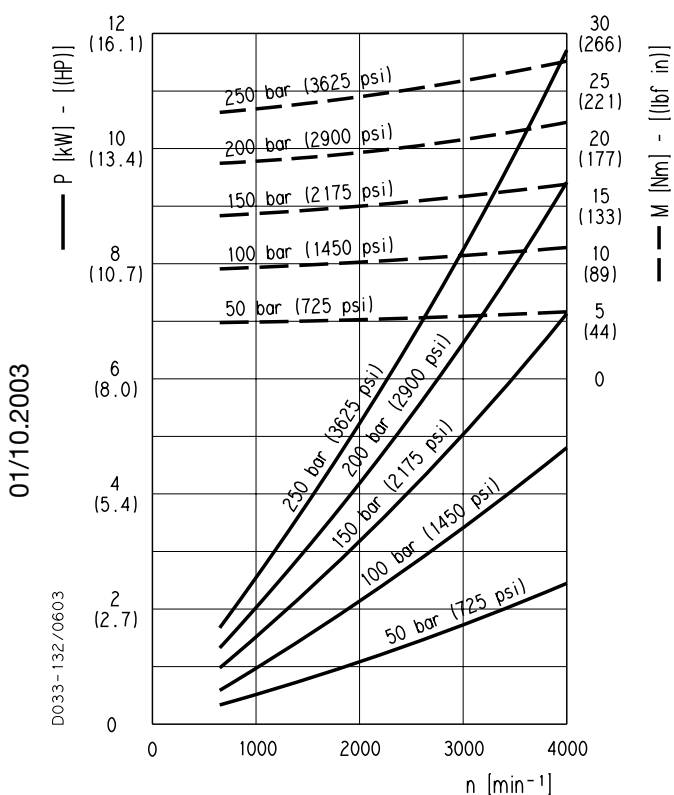

PLP 10•5,8

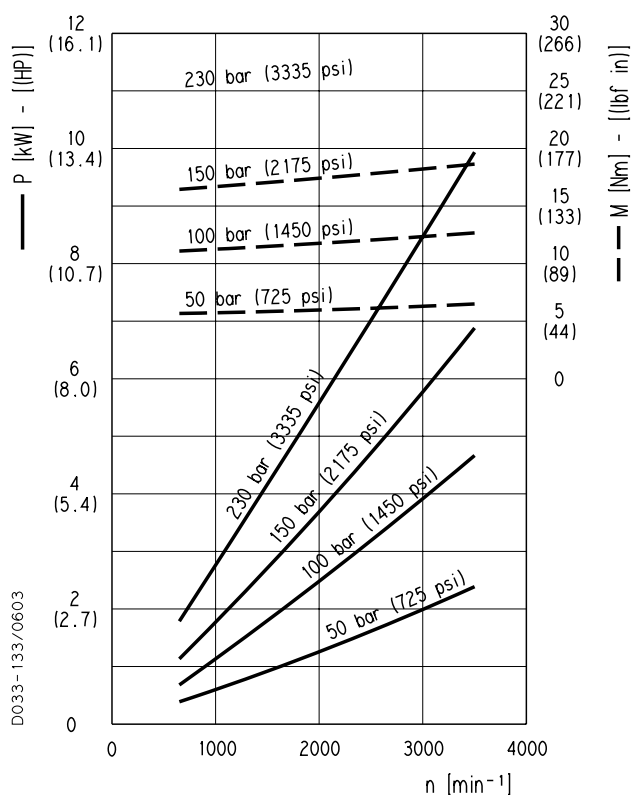

01/10.2003

PLP 10

POLARIS 10 GEAR PUMPS PERFORMANCE CURVES

PLP 10•6,3

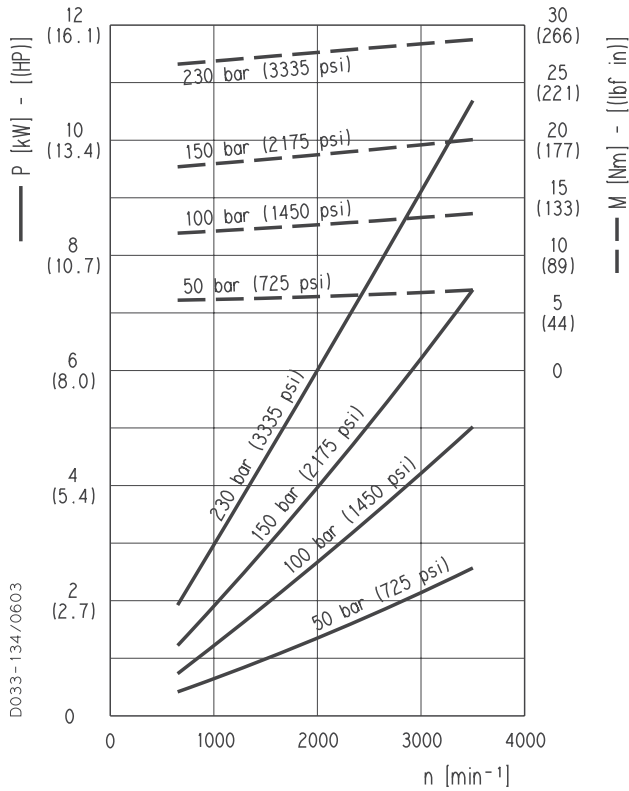

PLP 10•8

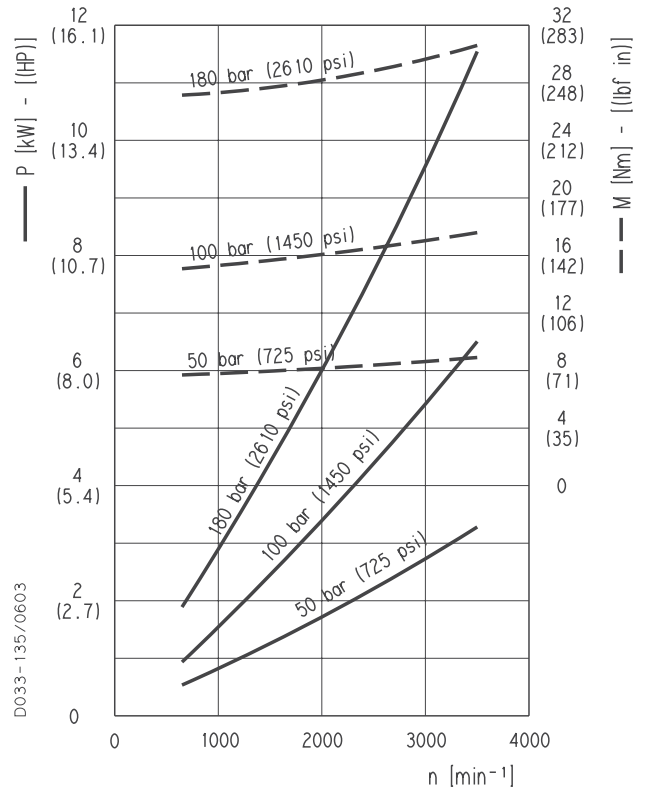

PLP 10•10

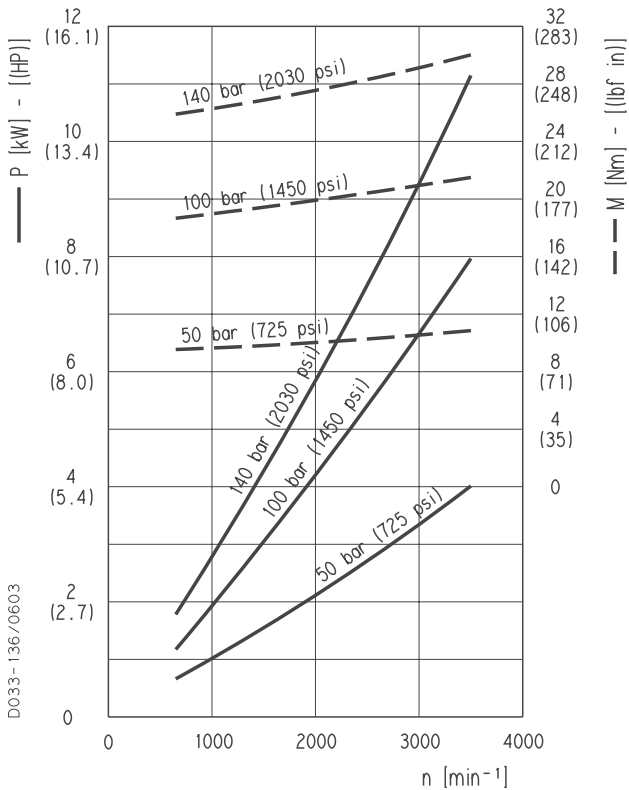

01/10.2003

PLP 20

POLARIS 20 GEAR PUMPS PERFORMANCE CURVES

PLP 20

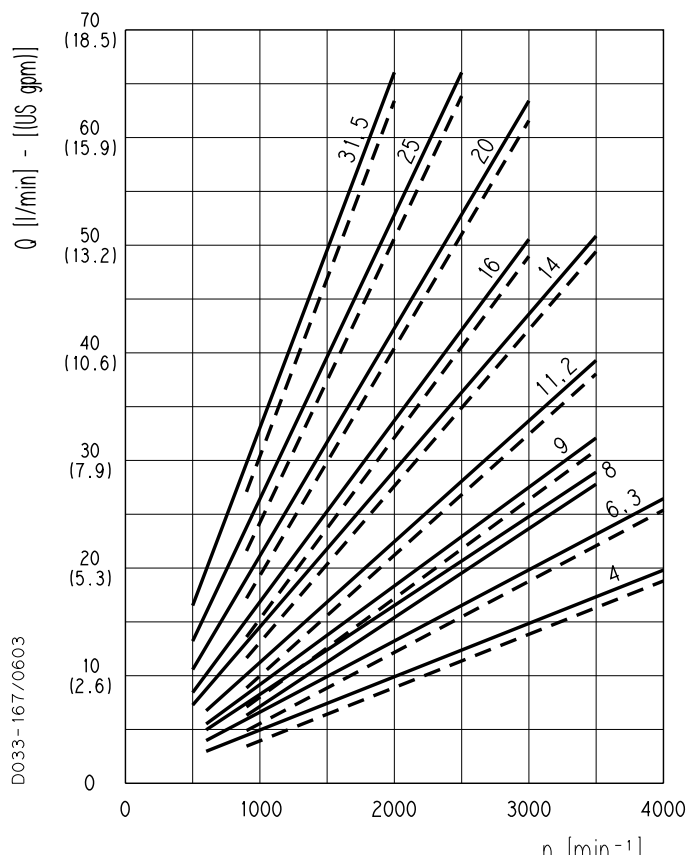

Each curve has been obtained at 50 °C (122 °F), using oil with viscosity 46 cSt (210 SSU) at 40 °C (104 °F) and at these pressures.

PLP 20•4 ——— 20 bar (290 psi)
 - - - 250 bar (3625 psi)

PLP 20•6,3 ——— 20 bar (290 psi)
 - - - 250 bar (3625 psi)

PLP 20•8 ——— 20 bar (290 psi)
 - - - 250 bar (3625 psi)

PLP 20•9 ——— 20 bar (290 psi)
 - - - 250 bar (3625 psi)

PLP 20•11,2 ——— 20 bar (290 psi)
 - - - 250 bar (3625 psi)

PLP 20•14 ——— 20 bar (290 psi)
 - - - 250 bar (3625 psi)

PLP 20•16 ——— 20 bar (290 psi)
 - - - 250 bar (3625 psi)

PLP 20•20 ——— 20 bar (290 psi)
 - - - 200 bar (2900 psi)

PLP 20•25 ——— 20 bar (290 psi)
 - - - 170 bar (2465 psi)

PLP 20•31,5 ——— 20 bar (290 psi)
 - - - 130 bar (1885 psi)

PLP 20•7,2 ——— 20 bar (290 psi)
 - - - 250 bar (3625 psi)

PLP 20•10,5 ——— 20 bar (290 psi)
 - - - 250 bar (3625 psi)

PLP 20•19 ——— 20 bar (290 psi)
 - - - 200 bar (2900 psi)

PLP 20•24,5 ——— 20 bar (290 psi)
 - - - 270 bar (2465 psi)

PLP 20•27,8 ——— 20 bar (290 psi)
 - - - 130 bar (1885 psi)

01/10.2003

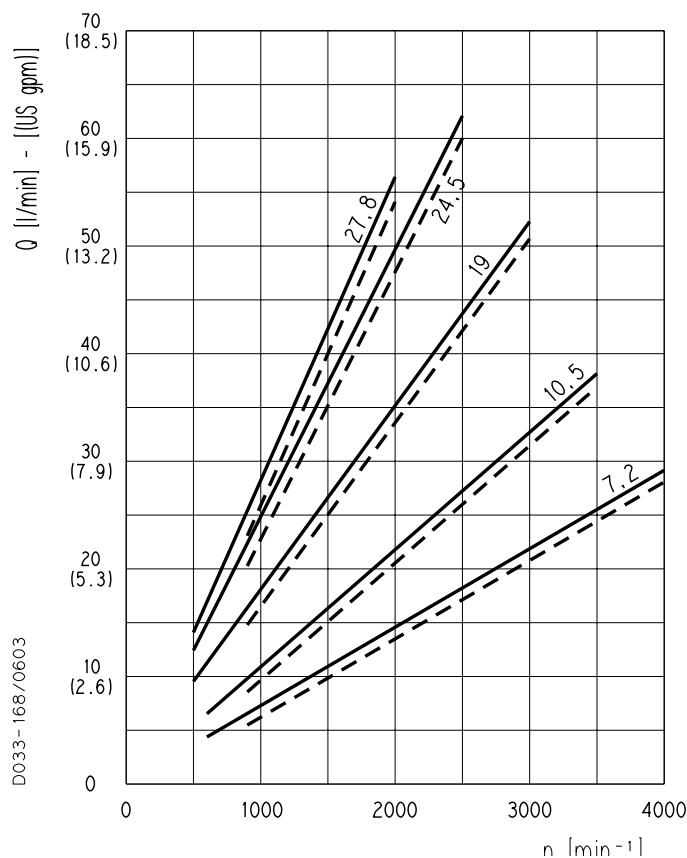

PLP 20

POLARIS 20 GEAR PUMPS PERFORMANCE CURVES

PLP 20•4

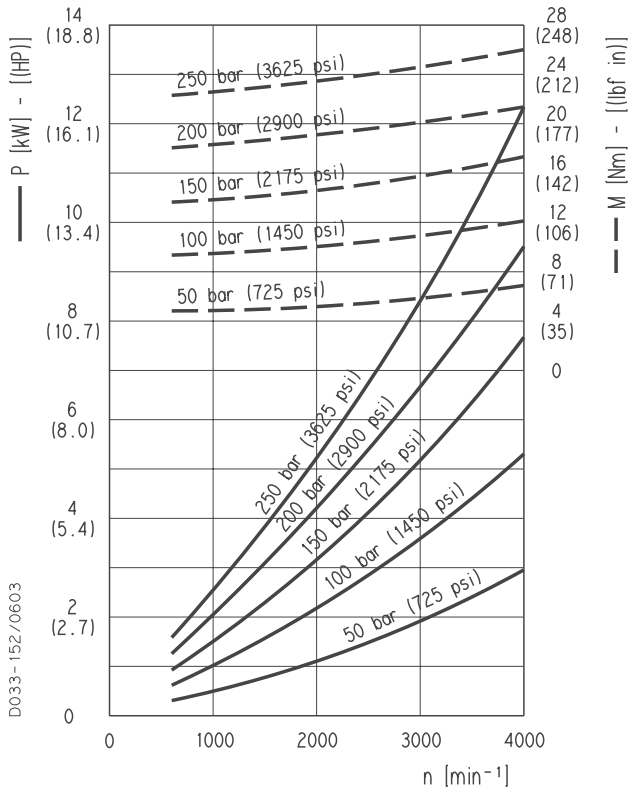

PLP 20•6,3

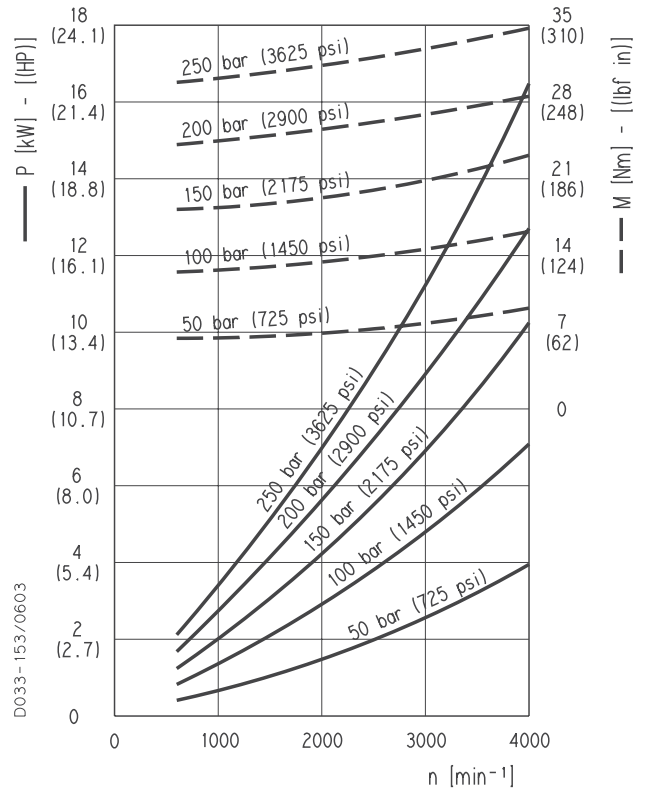

PLP 20•7,2

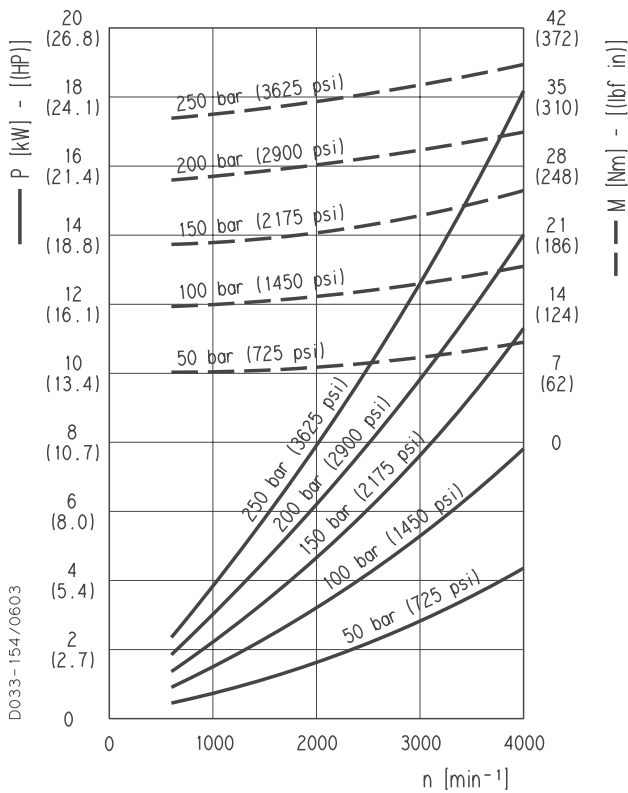

PLP 20•8

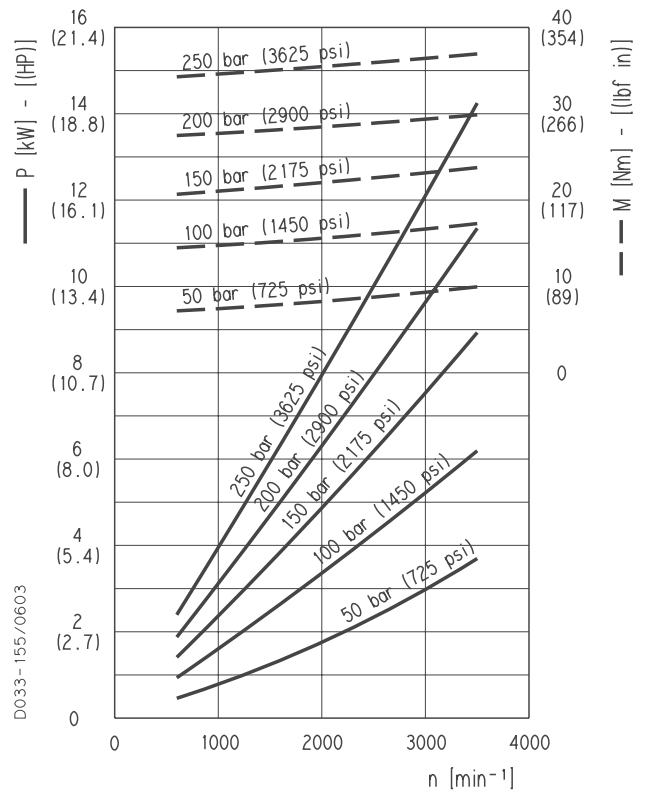

01/10.2003

PLP 20

POLARIS 20 GEAR PUMPS PERFORMANCE CURVES

PLP 20•9

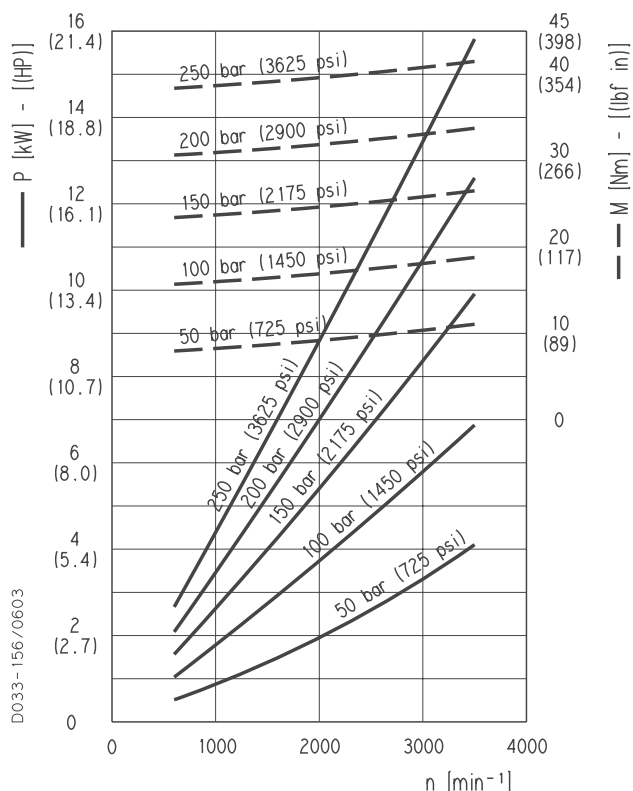

PLP 20•10,5

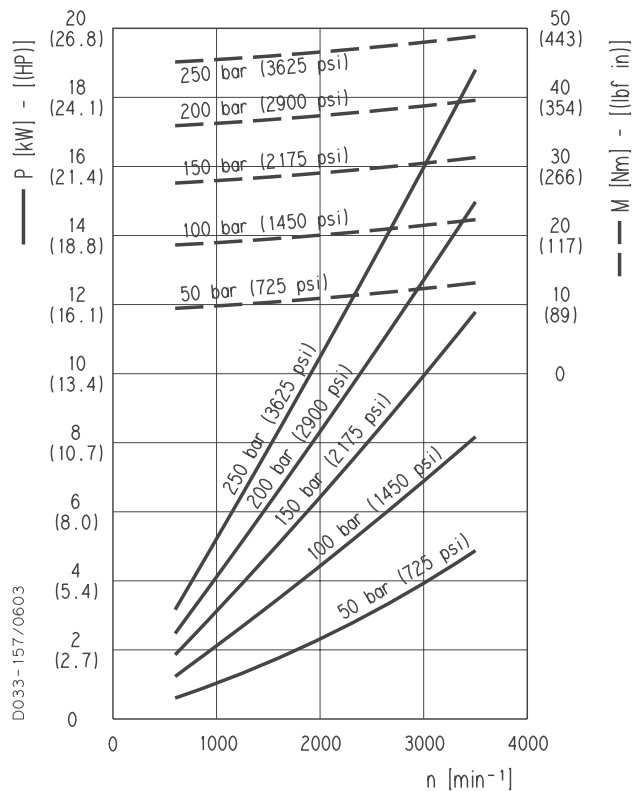

PLP 20•11,2

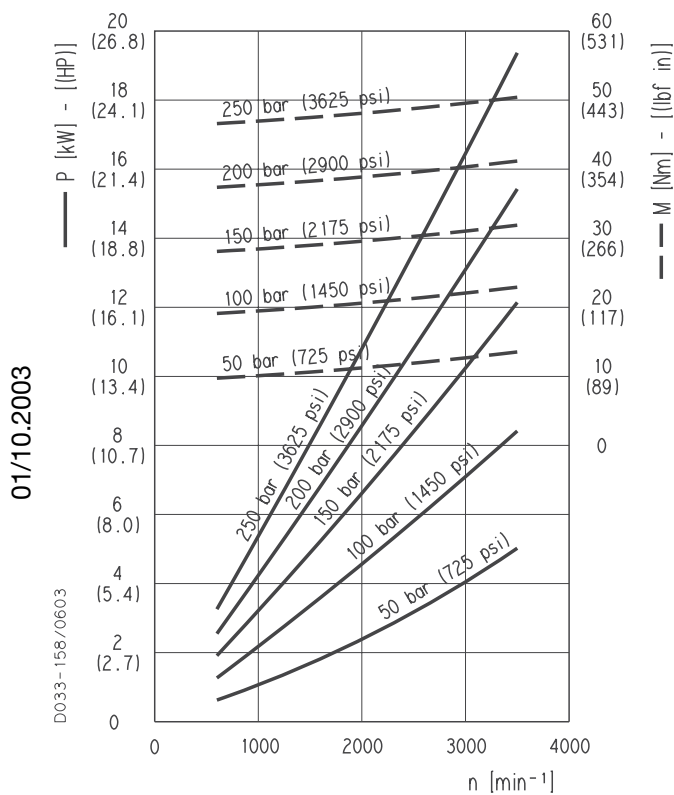

PLP 20•14

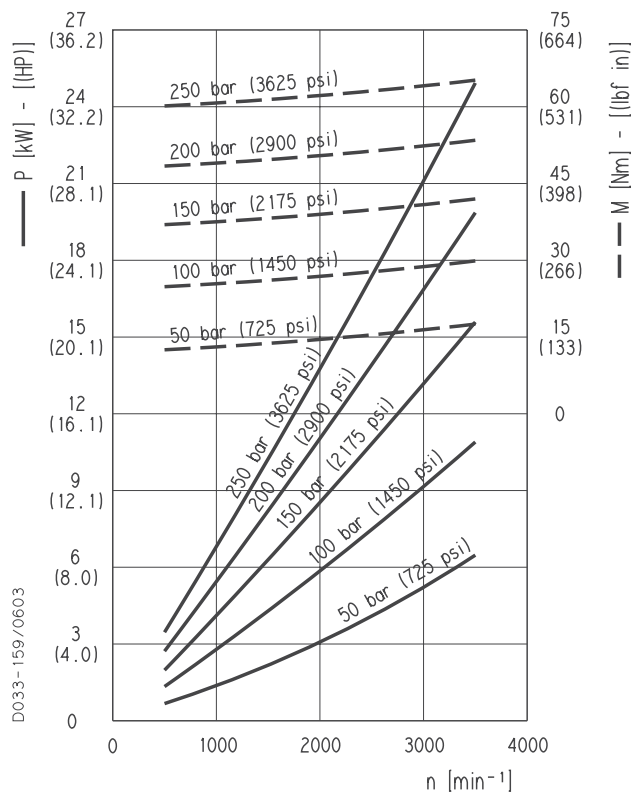

PLP 20

POLARIS 20 GEAR PUMPS PERFORMANCE CURVES

PLP 20•16

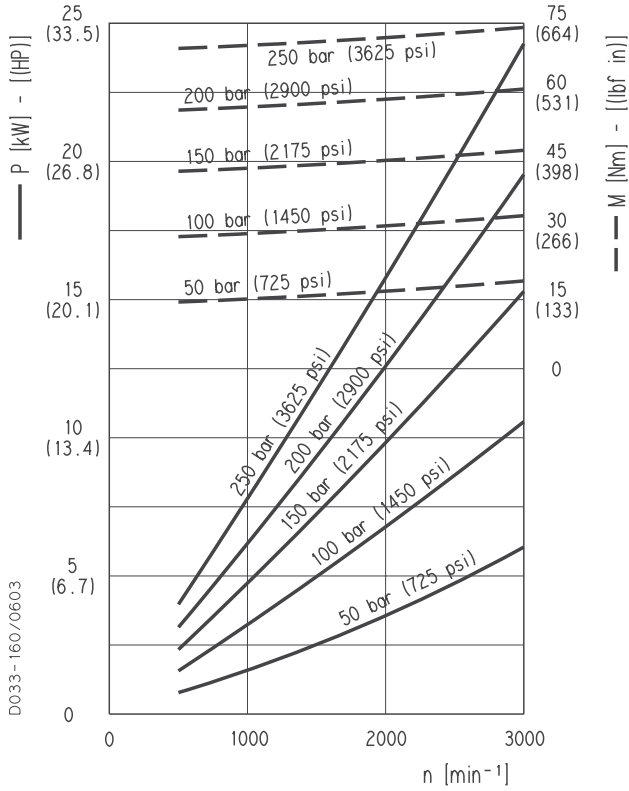

PLP 20•19

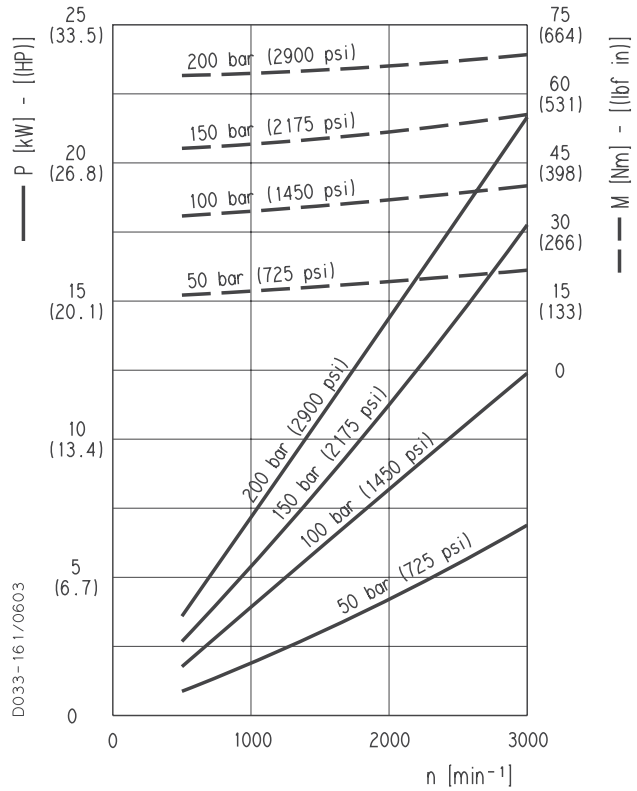

PLP 20•20

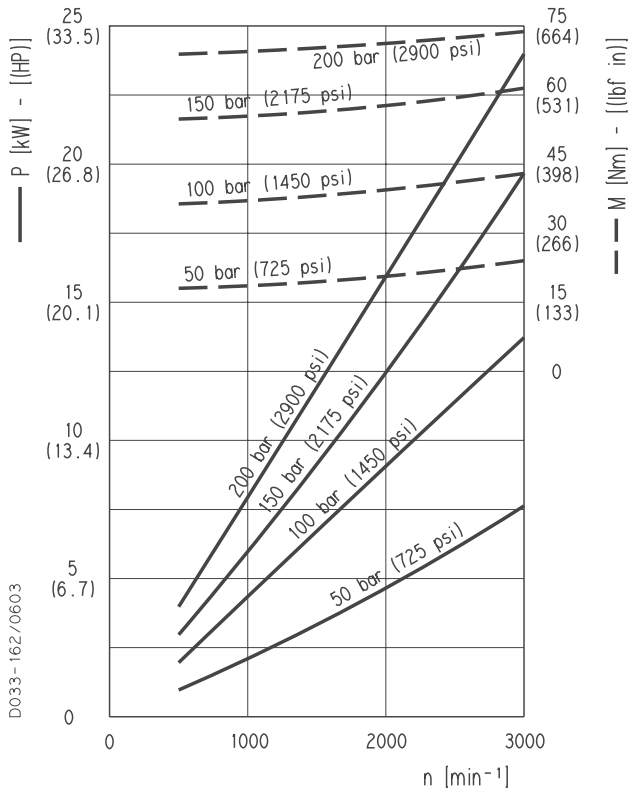

PLP 20•24,5

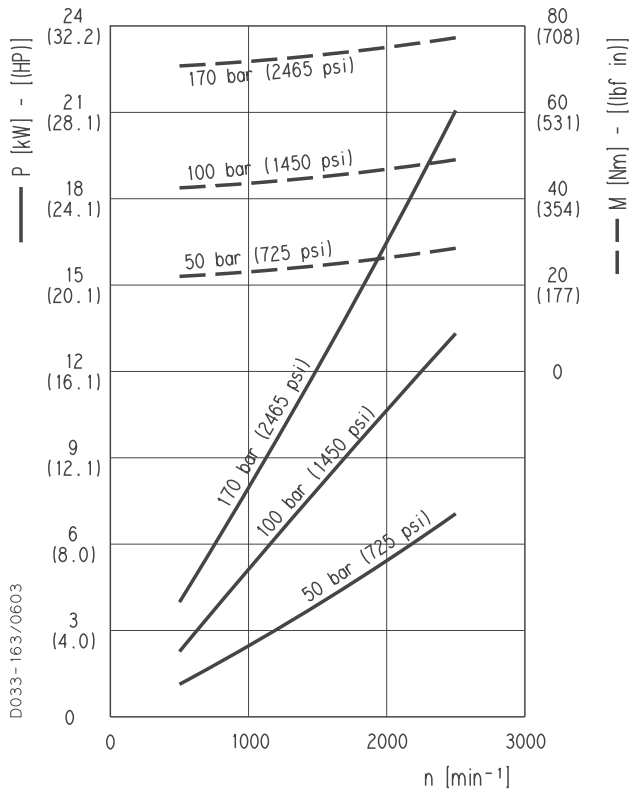

01/10.2003

PLP 20

POLARIS 20 GEAR PUMPS PERFORMANCE CURVES

PLP 20•25

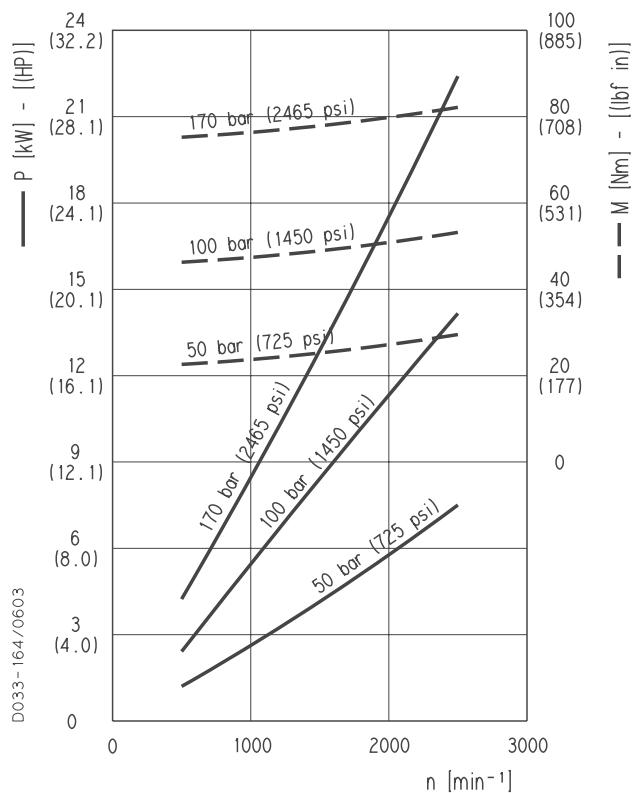

PLP 20•27,8

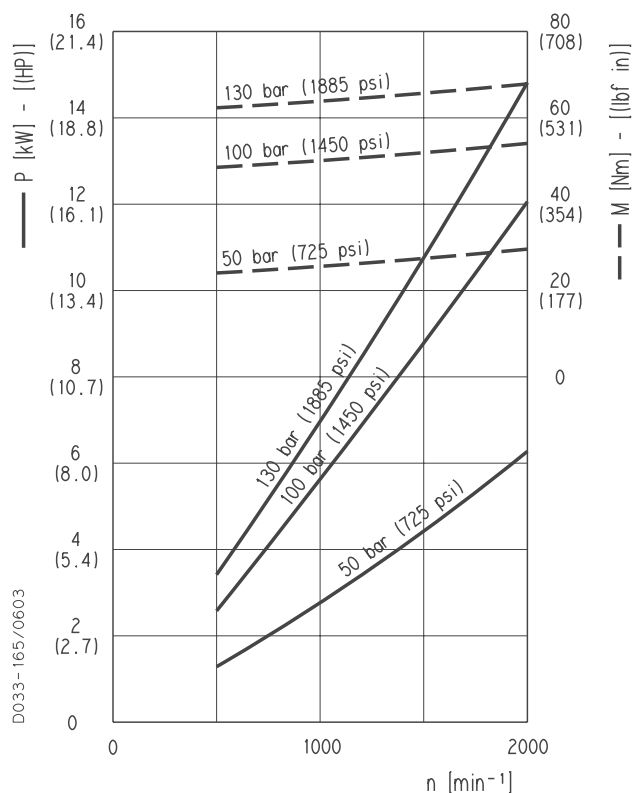

PLP 20•31,5

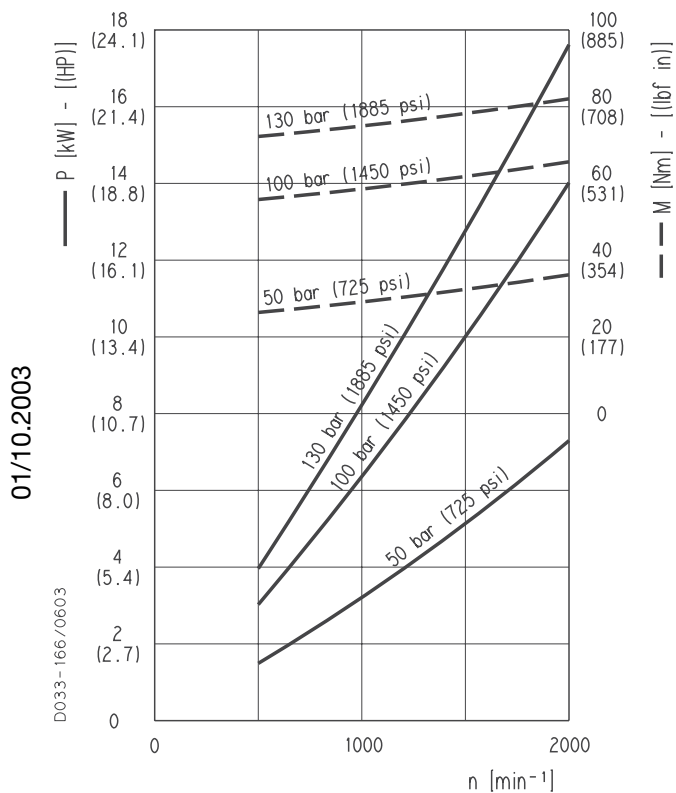

01/10.2003

PLP 30

POLARIS 30 GEAR PUMPS PERFORMANCE CURVES

Each curve has been obtained at 50 °C (122 °F), using oil with viscosity 46 cSt (210 SSU) at 40 °C (104 °F) and at these pressures.

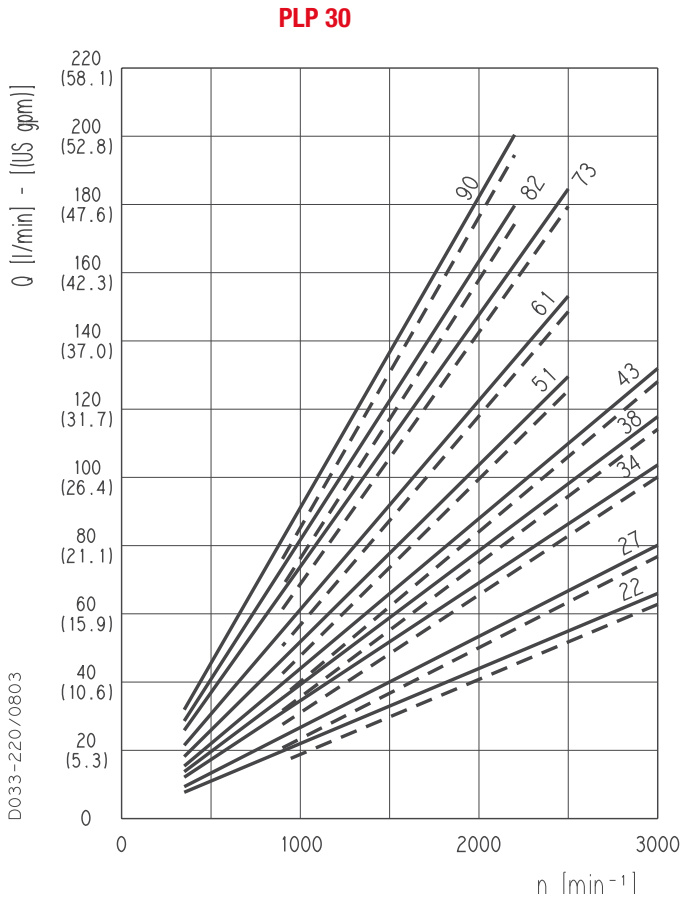

PLP 30•22	—	20 bar (290 psi)
	- - -	250 bar (3625 psi)
PLP 30•27	—	20 bar (290 psi)
	- - -	250 bar (3625 psi)
PLP 30•34	—	20 bar (290 psi)
	- - -	240 bar (3480 psi)
PLP 30•38	—	20 bar (290 psi)
	- - -	240 bar (3480 psi)
PLP 30•43	—	20 bar (290 psi)
	- - -	230 bar (3335 psi)
PLP 30•51	—	20 bar (290 psi)
	- - -	210 bar (3045 psi)
PLP 30•61	—	20 bar (290 psi)
	- - -	190 bar (2775 psi)
PLP 30•73	—	20 bar (290 psi)
	- - -	170 bar (2465 psi)
PLP 30•82	—	20 bar (290 psi)
	- - -	160 bar (2320 psi)
PLP 30•90	—	20 bar (290 psi)
	- - -	150 bar (2175 psi)

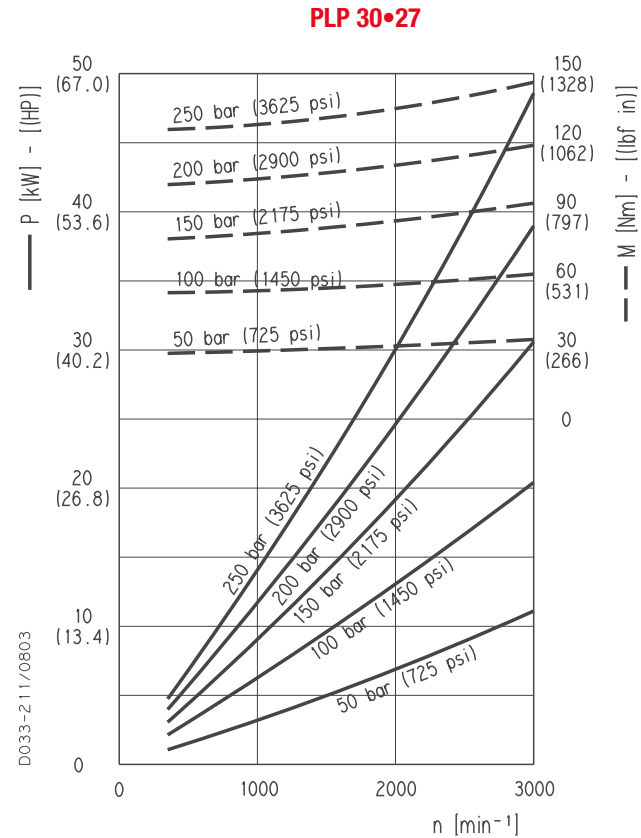
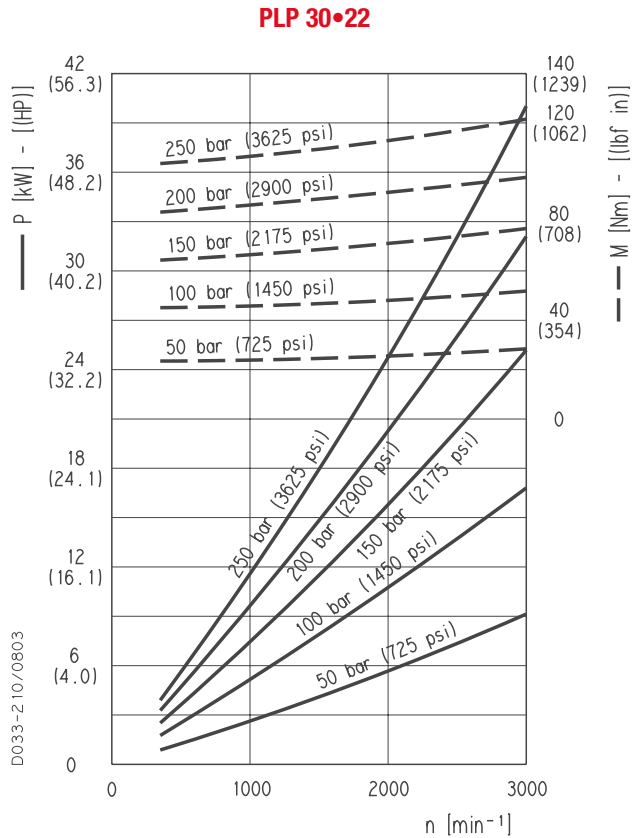

01/10.2003

PLP 30

POLARIS 30 GEAR PUMPS PERFORMANCE CURVES

PLP 30•34

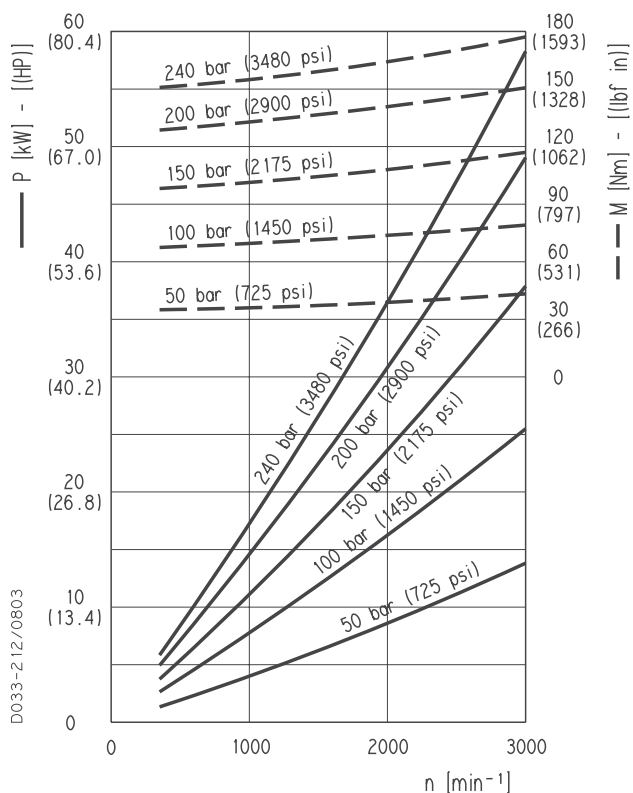

PLP 30•38

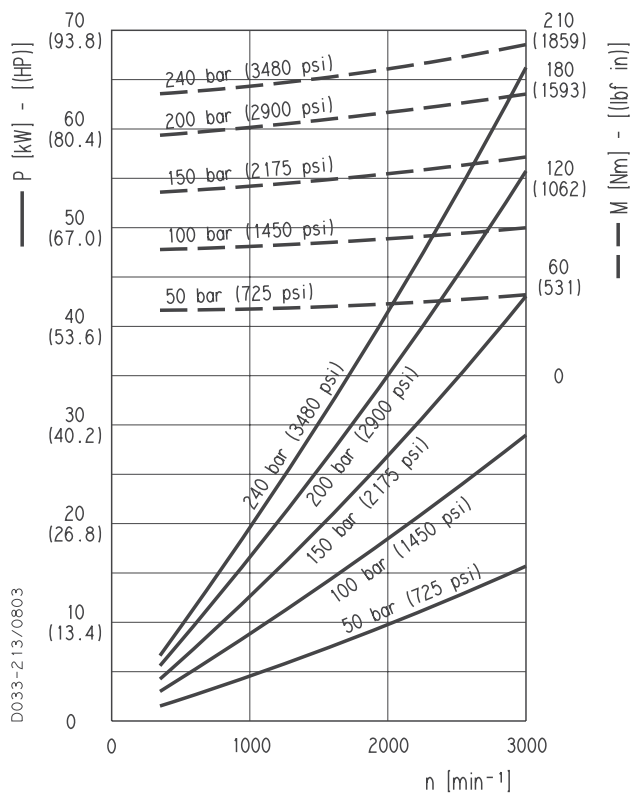

PLP 30•43

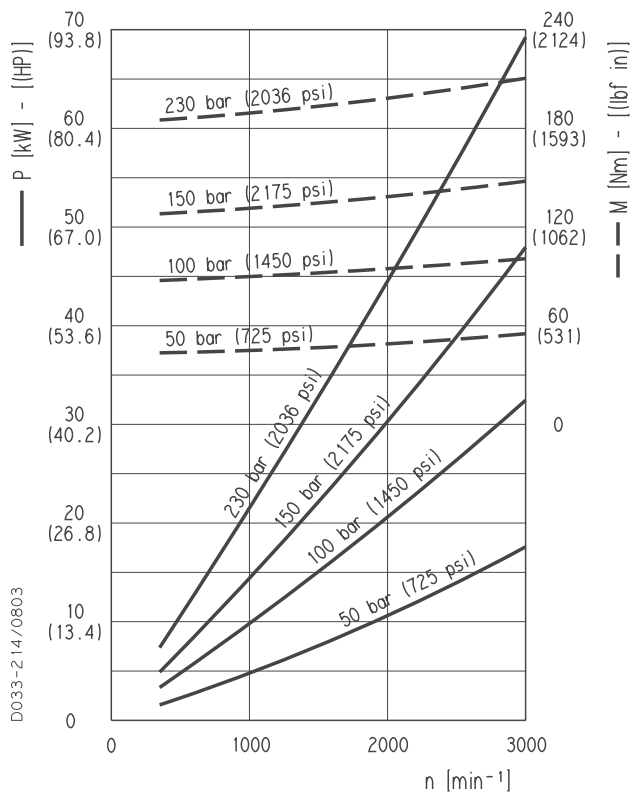

PLP 30•51

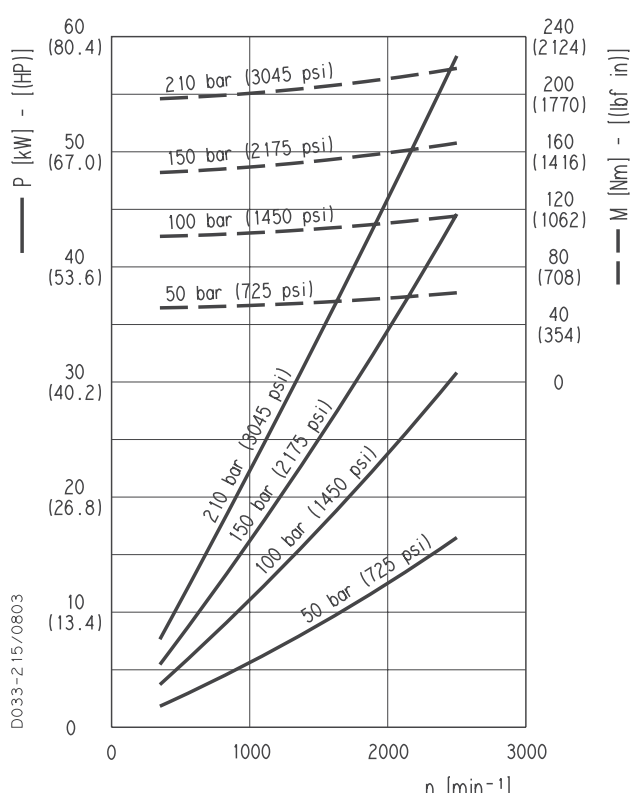

01/10.2003

PLP 30

POLARIS 30 GEAR PUMPS PERFORMANCE CURVES

PLP 30•61

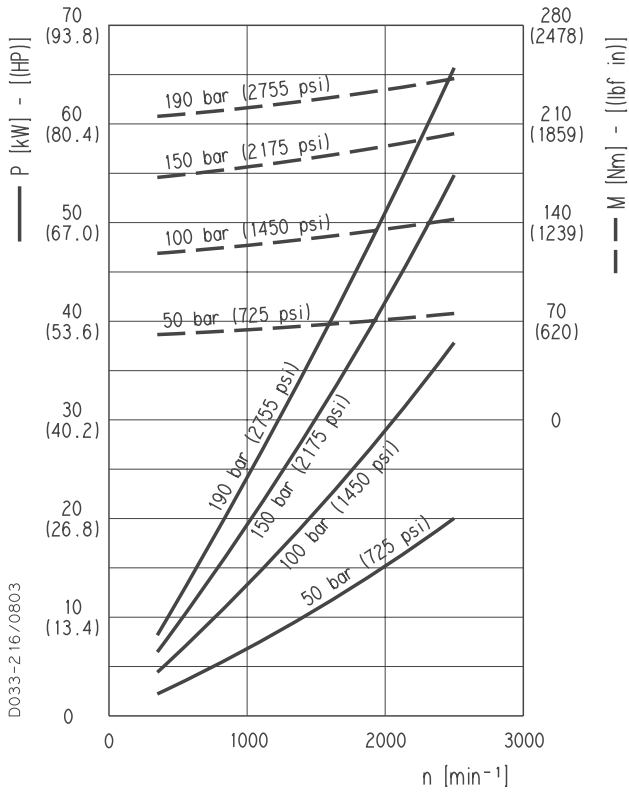

PLP 30•73

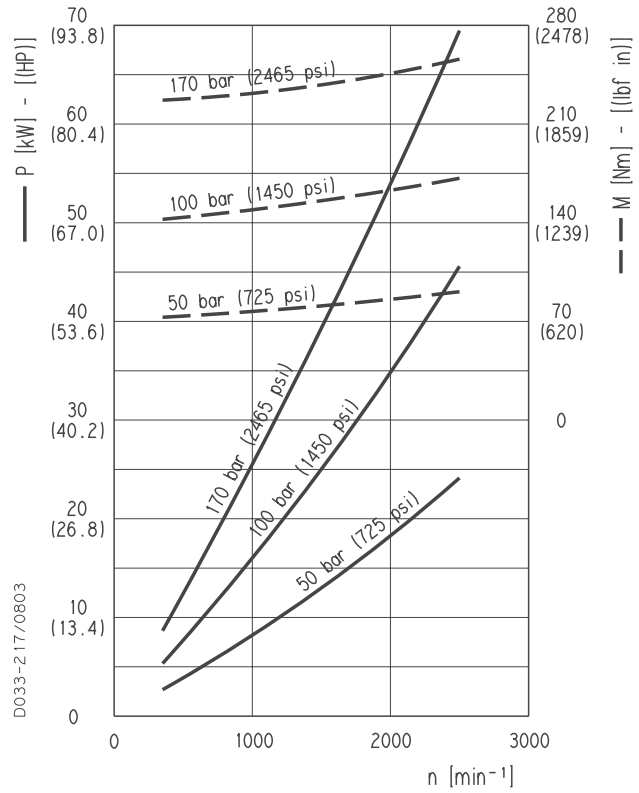

PLP 30•82

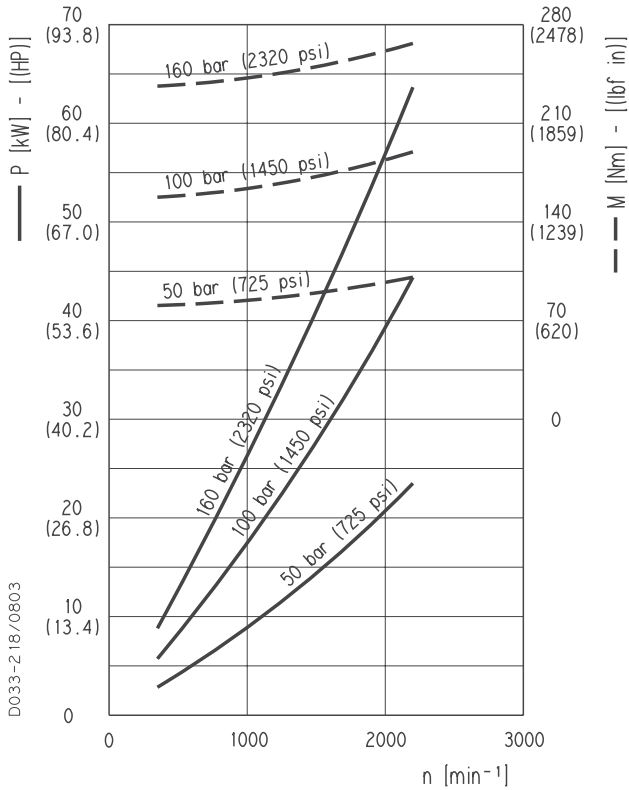

PLP 30•90

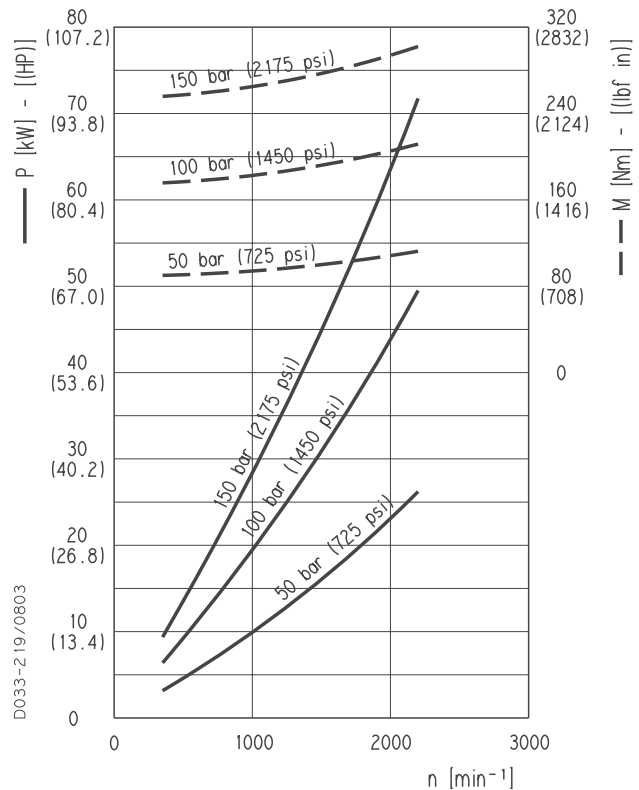

01/10.2003

PLM 10

POLARIS 10 GEAR MOTORS PERFORMANCE CURVES

PLM 10

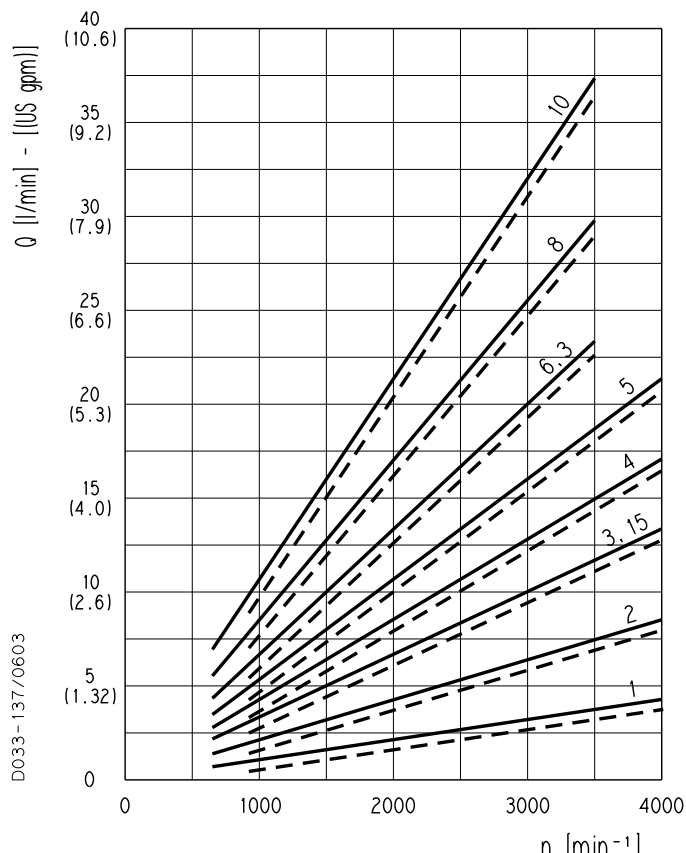

Each curve has been obtained at 50 °C (122 °F), using oil with viscosity 46 cSt (210 SSU) at 40 °C (104 °F) and at these pressures.

PLM 10•1	—	20 bar (290 psi)
	- - -	260 bar (3770 psi)
PLM 10•2	—	20 bar (290 psi)
	- - -	260 bar (3770 psi)
PLM 10•3,15	—	20 bar (290 psi)
	- - -	260 bar (3770 psi)
PLM 10•4	—	20 bar (290 psi)
	- - -	250 bar (3625 psi)
PLM 10•5	—	20 bar (290 psi)
	- - -	250 bar (3625 psi)
PLM 10•6,3	—	20 bar (290 psi)
	- - -	230 bar (3335 psi)
PLM 10•8	—	20 bar (290 psi)
	- - -	180 bar (2610 psi)
PLM 10•10	—	20 bar (290 psi)
	- - -	140 bar (2030 psi)

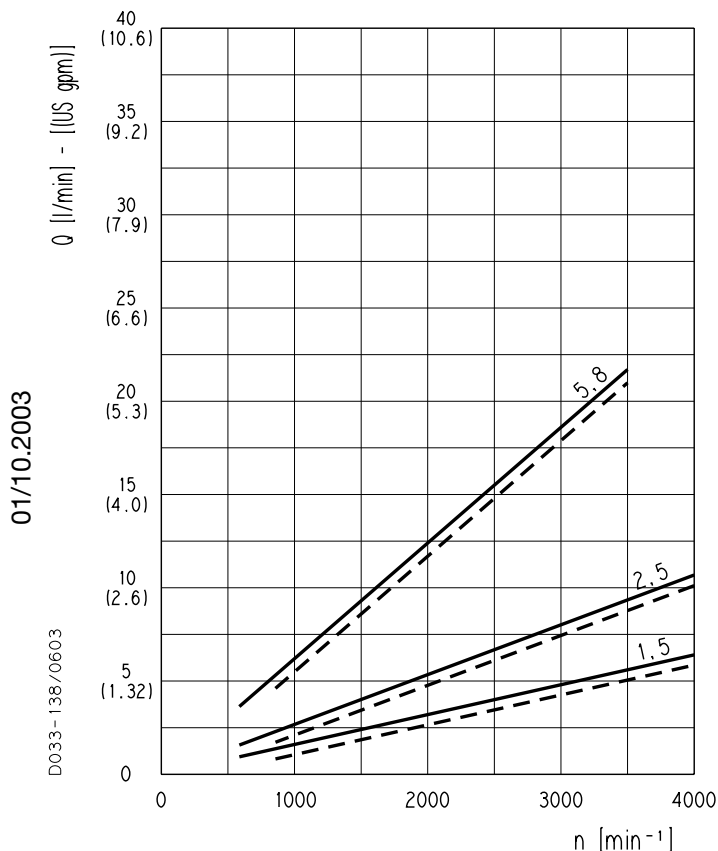

PLM 10•1,5	—	20 bar (290 psi)
	- - -	260 bar (3770 psi)
PLM 10•2,5	—	20 bar (290 psi)
	- - -	260 bar (3770 psi)
PLM 10•5,8	—	20 bar (290 psi)
	- - -	230 bar (3335 psi)

PLM 10

POLARIS 10 GEAR MOTORS PERFORMANCE CURVES

PLM 10•1

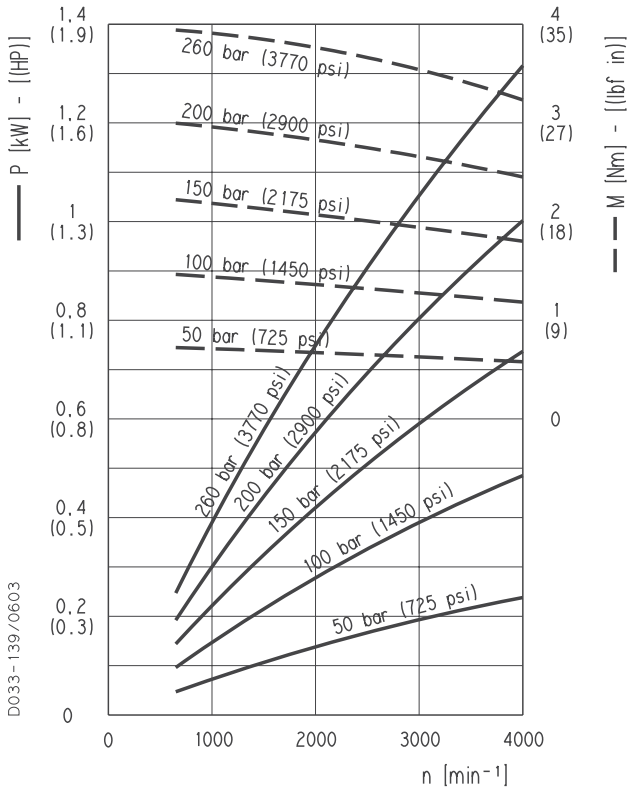

PLM 10•1,5

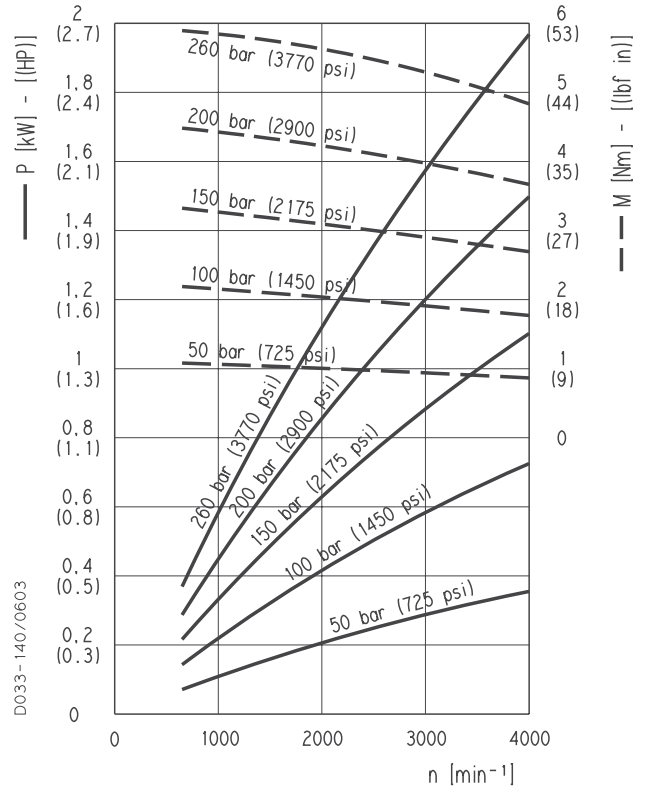

PLM 10•2

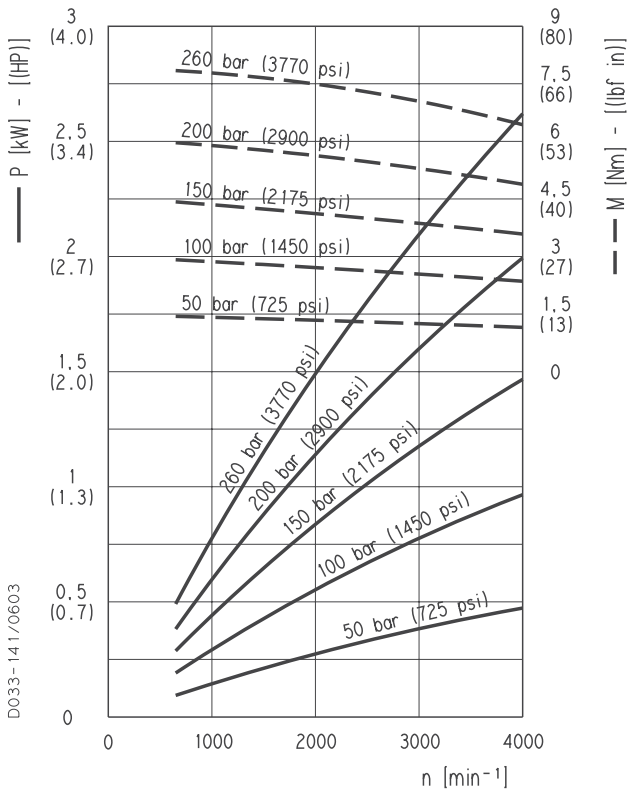

PLM 10•2,5

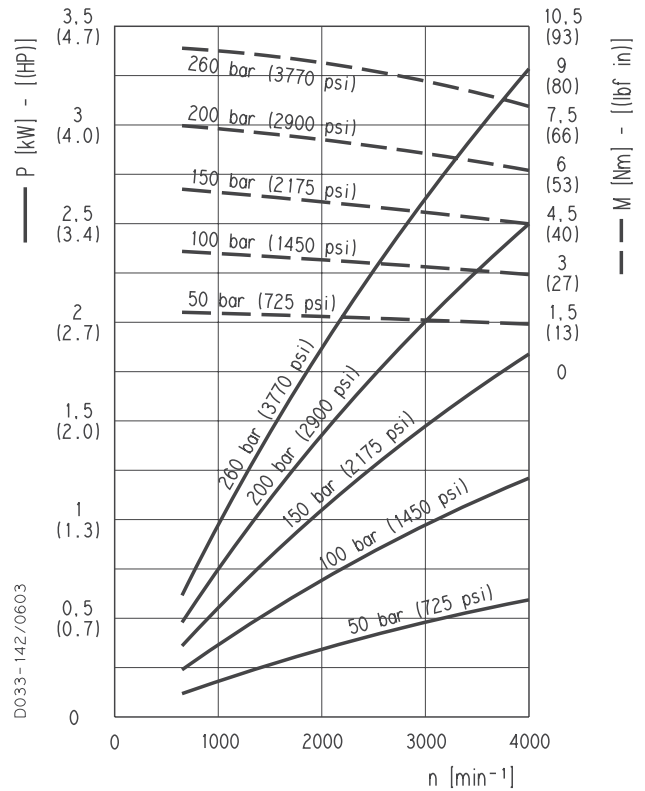

01/10.2003

PLM 10

POLARIS 10 GEAR MOTORS PERFORMANCE CURVES

PLM 10•3,15

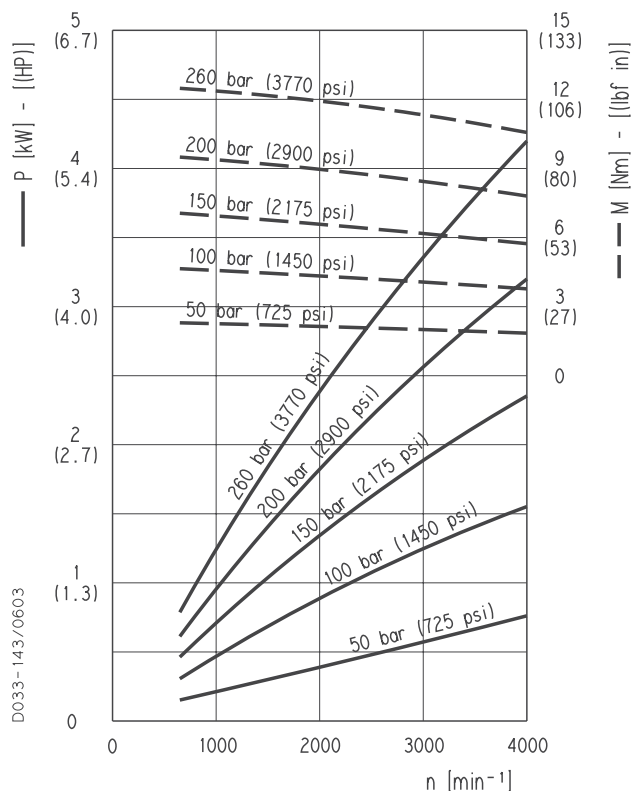

PLM 10•4

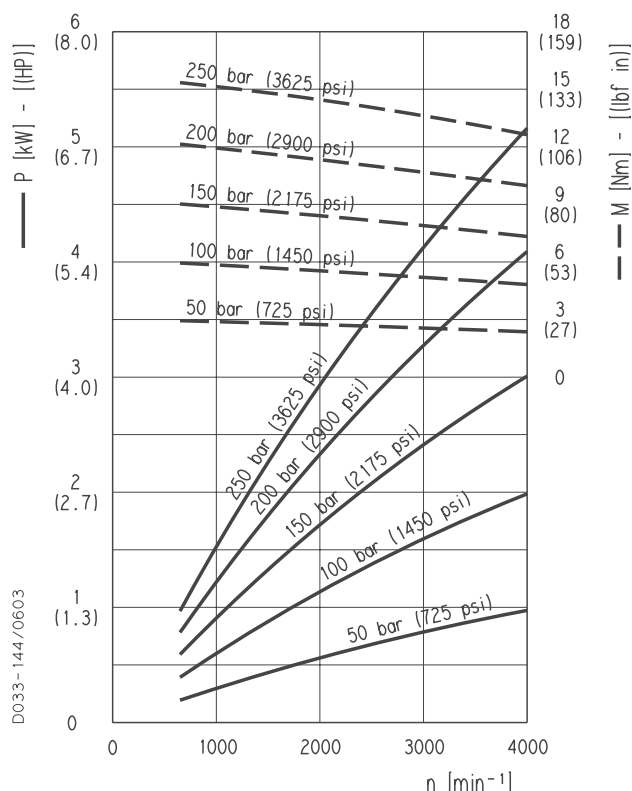

PLM 10•5

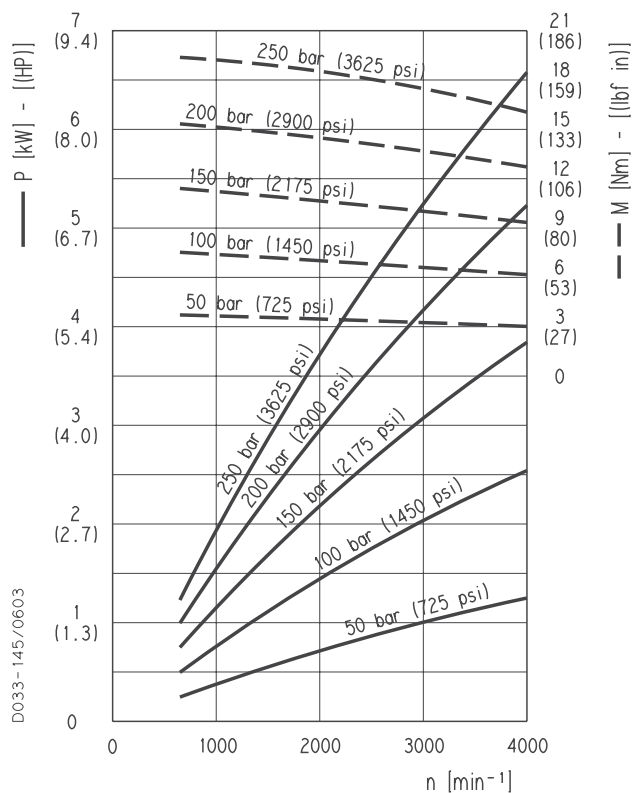

PLM 10•5,8

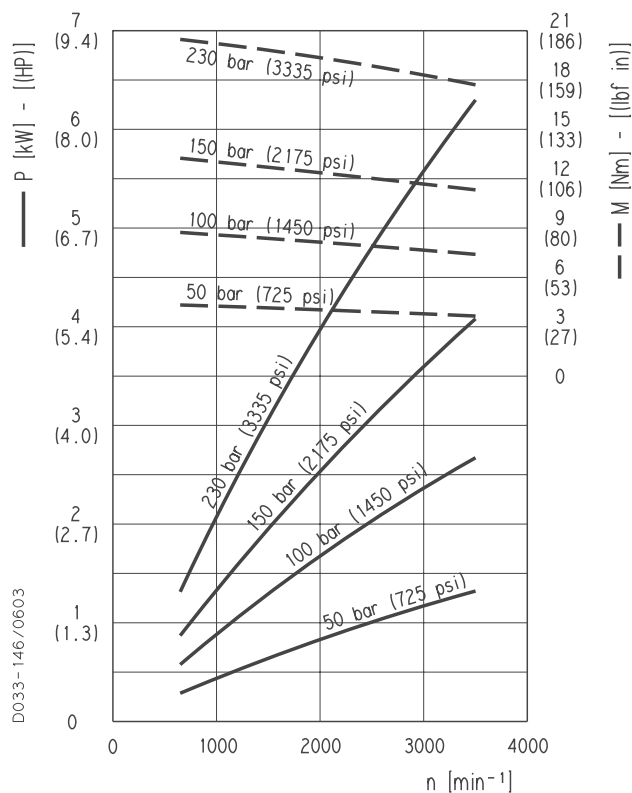

01/10.2003

PLM 10

POLARIS 10 GEAR MOTORS PERFORMANCE CURVES

PLM 10•6,3

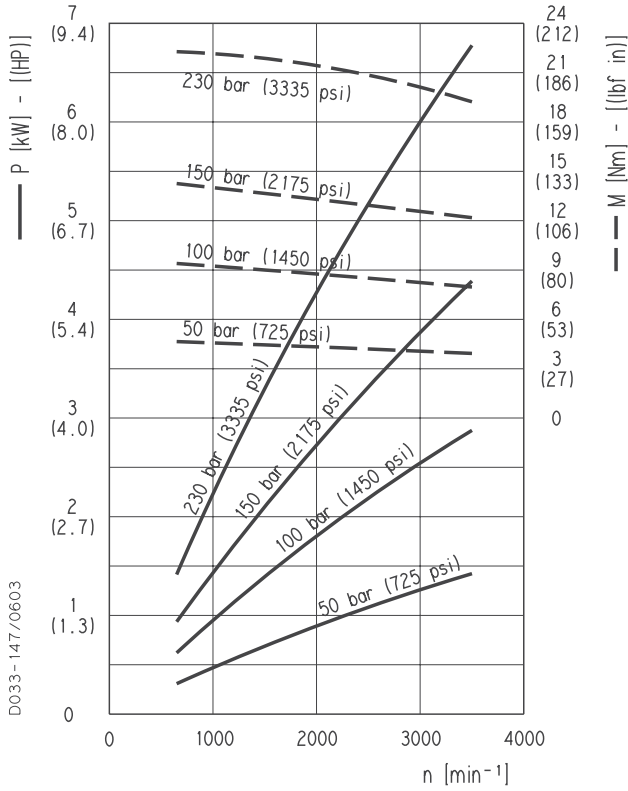

PLM 10•8

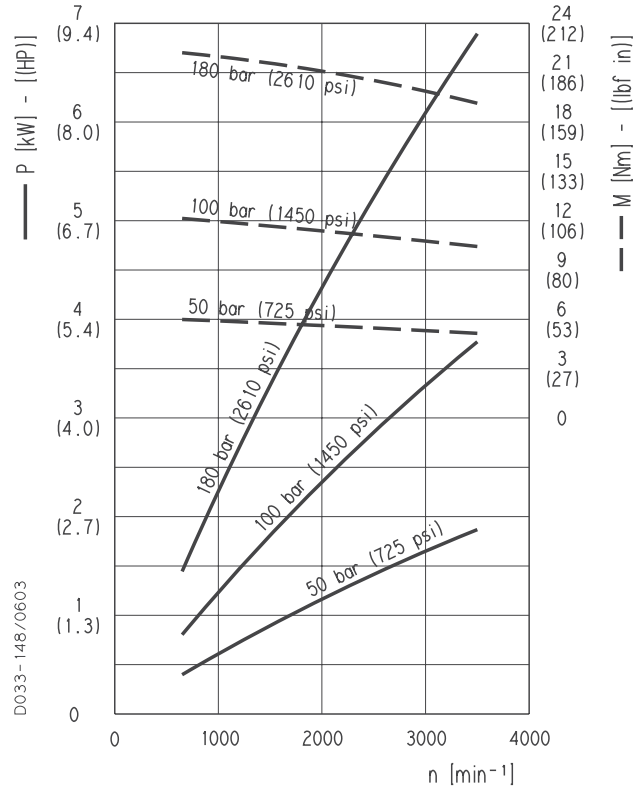

PLM 10•10

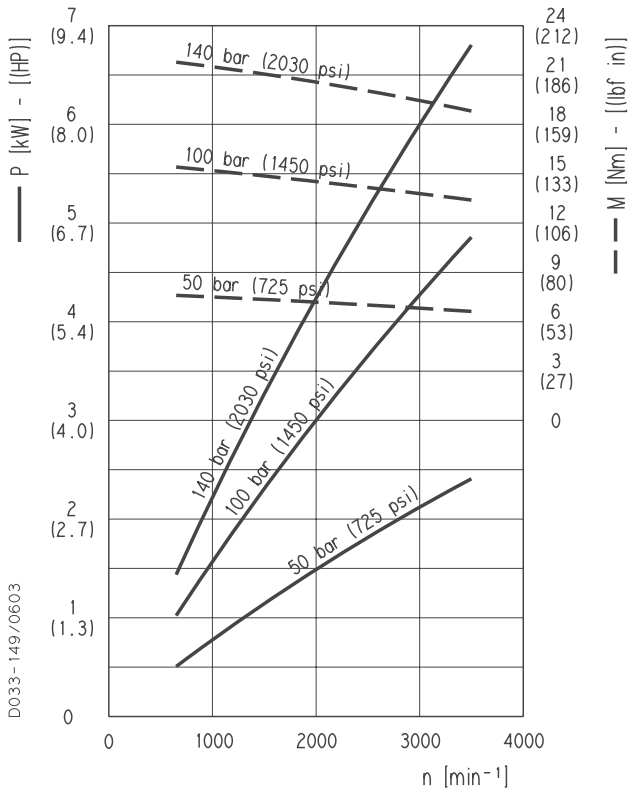

01/10.2003

PLM 20

POLARIS 20 GEAR MOTORS PERFORMANCE CURVES

PLM 20

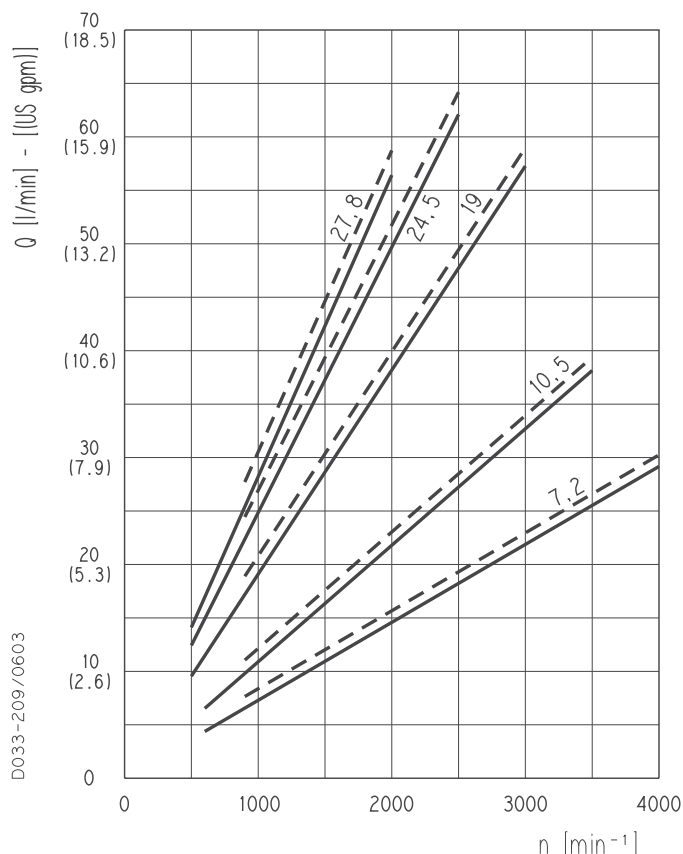
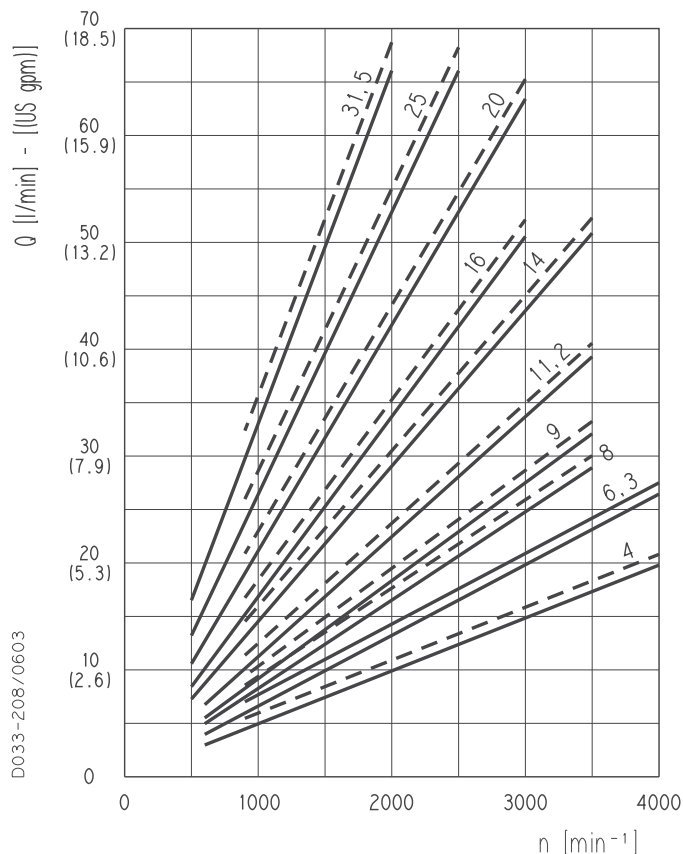

Each curve has been obtained at 50 °C (122 °F), using oil with viscosity 46 cSt (210 SSU) at 40 °C (104 °F) and at these pressures.

PLM 20•4	—	20 bar (290 psi)
	- - -	250 bar (3625 psi)
PLM 20•6,3	—	20 bar (290 psi)
	- - -	250 bar (3625 psi)
PLM 20•8	—	20 bar (290 psi)
	- - -	250 bar (3625 psi)
PLM 20•9	—	20 bar (290 psi)
	- - -	250 bar (3625 psi)
PLM 20•11,2	—	20 bar (290 psi)
	- - -	250 bar (3625 psi)
PLM 20•14	—	20 bar (290 psi)
	- - -	250 bar (3625 psi)
PLM 20•16	—	20 bar (290 psi)
	- - -	250 bar (3625 psi)
PLM 20•20	—	20 bar (290 psi)
	- - -	200 bar (2900 psi)
PLM 20•25	—	20 bar (290 psi)
	- - -	170 bar (2465 psi)
PLM 20•31,5	—	20 bar (290 psi)
	- - -	130 bar (1885 psi)
PLM 20•7,2	—	20 bar (290 psi)
	- - -	250 bar (3625 psi)
PLM 20•10,5	—	20 bar (290 psi)
	- - -	250 bar (3625 psi)
PLM 20•19	—	20 bar (290 psi)
	- - -	200 bar (2900 psi)
PLM 20•24,5	—	20 bar (290 psi)
	- - -	270 bar (2465 psi)
PLM 20•27,8	—	20 bar (290 psi)
	- - -	130 bar (1885 psi)

01/10.2003

D033-209/0603

PLM 20

POLARIS 20 GEAR MOTORS PERFORMANCE CURVES

PLM 20•4

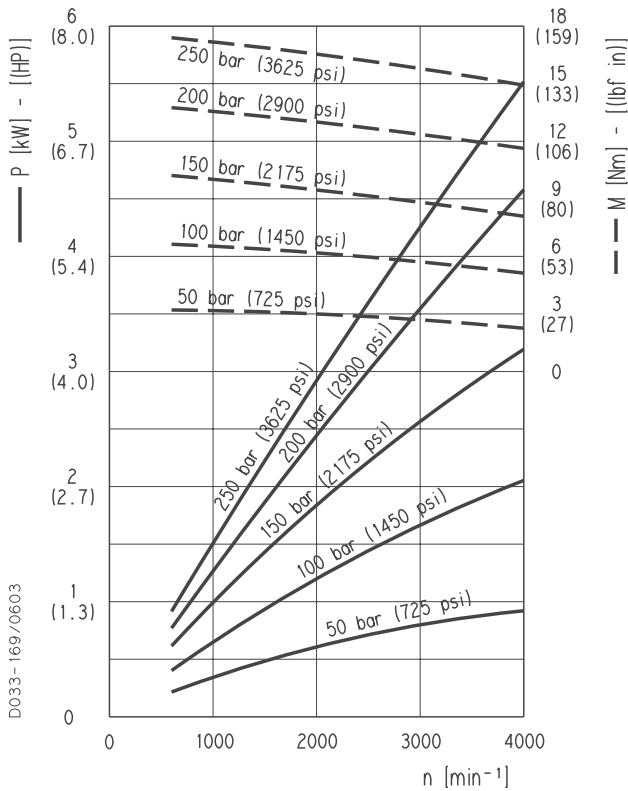

PLM 20•6,3

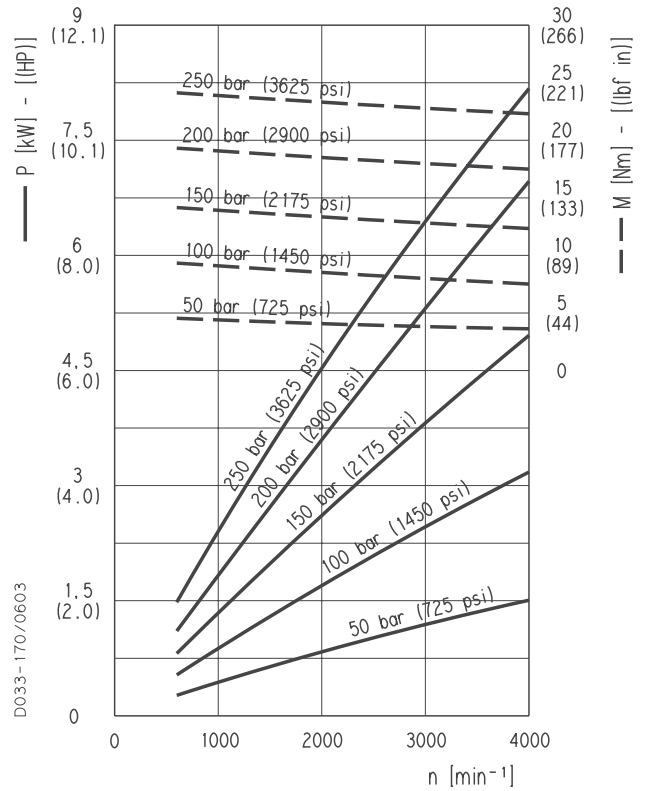

PLM 20•7,2

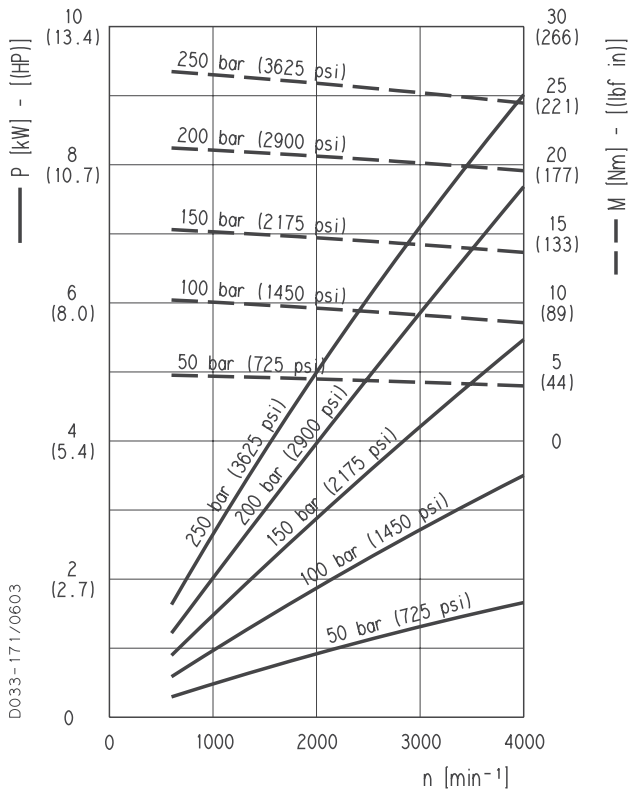

PLM 20•8

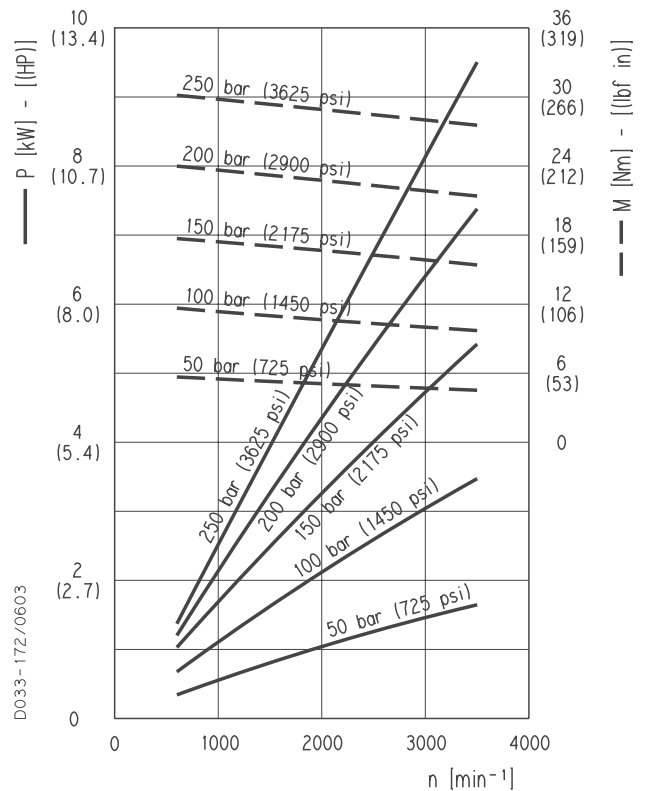

01/10.2003

PLM 20

POLARIS 20 GEAR MOTORS PERFORMANCE CURVES

PLM 20•9

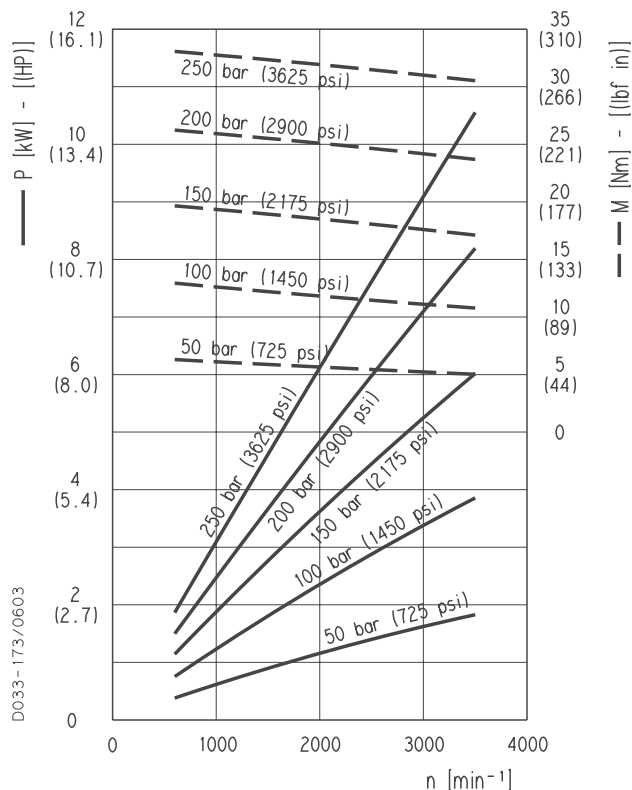

PLM 20•10,5

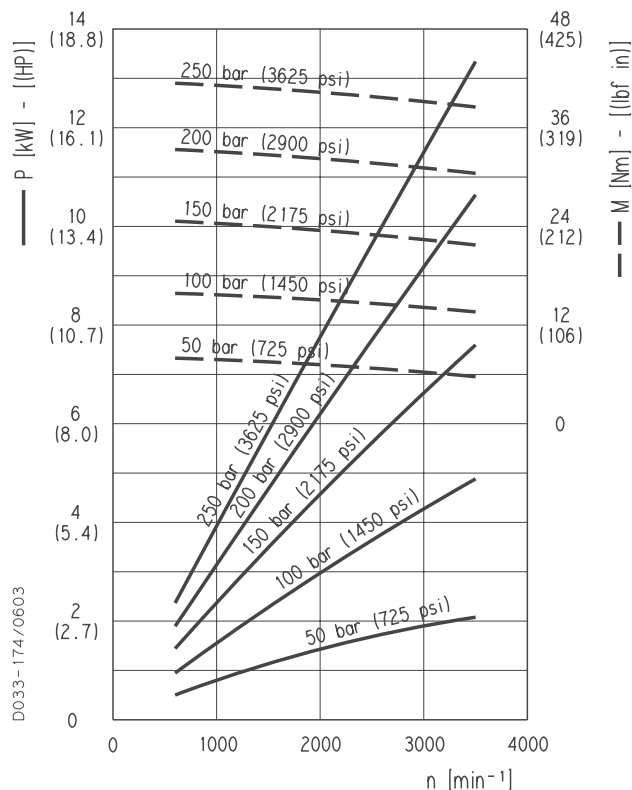

PLM 20•11,2

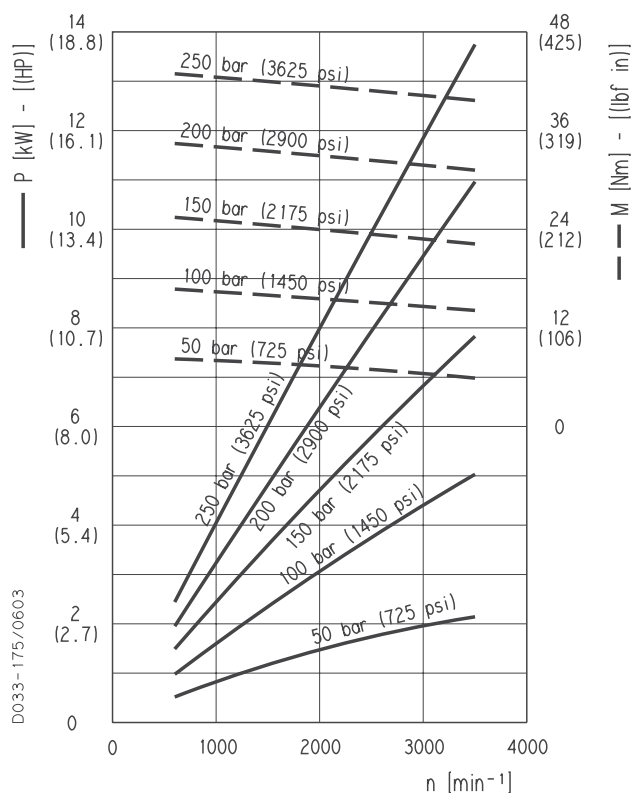

PLM 20•14

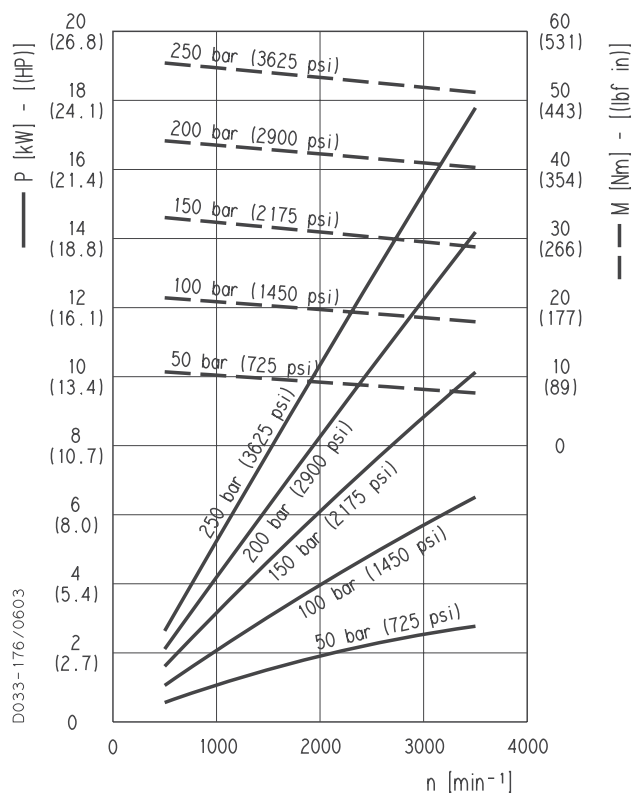

01/10.2003

PLM 20

POLARIS 20 GEAR MOTORS PERFORMANCE CURVES

PLM 20•16

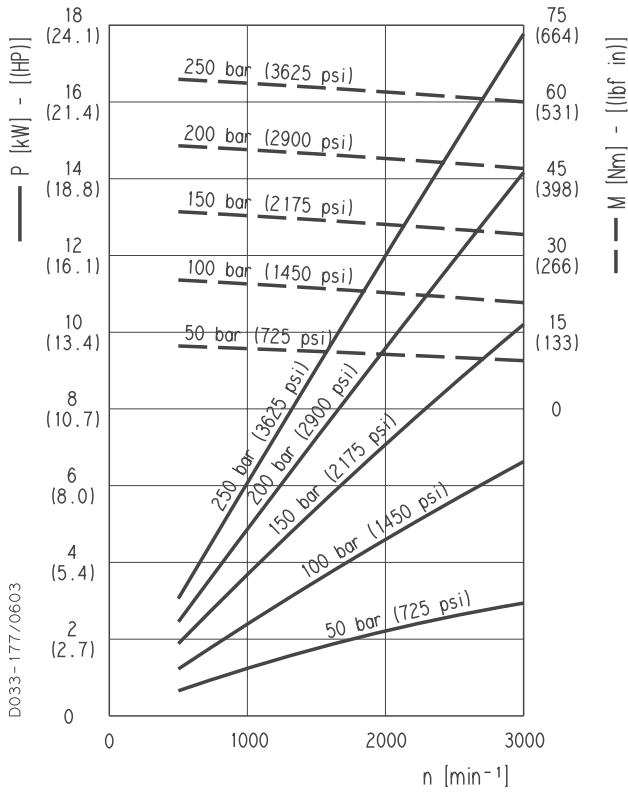

PLM 20•19

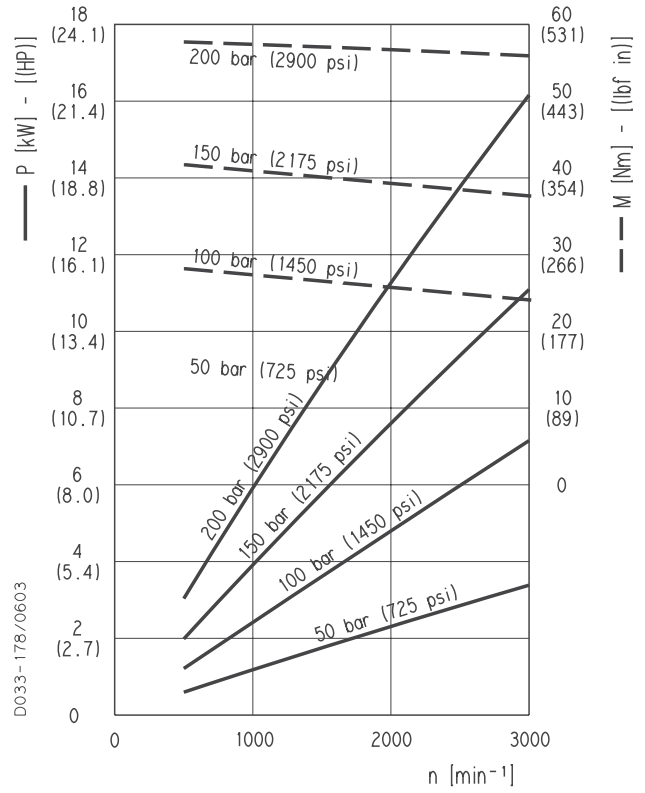

PLM 20•20

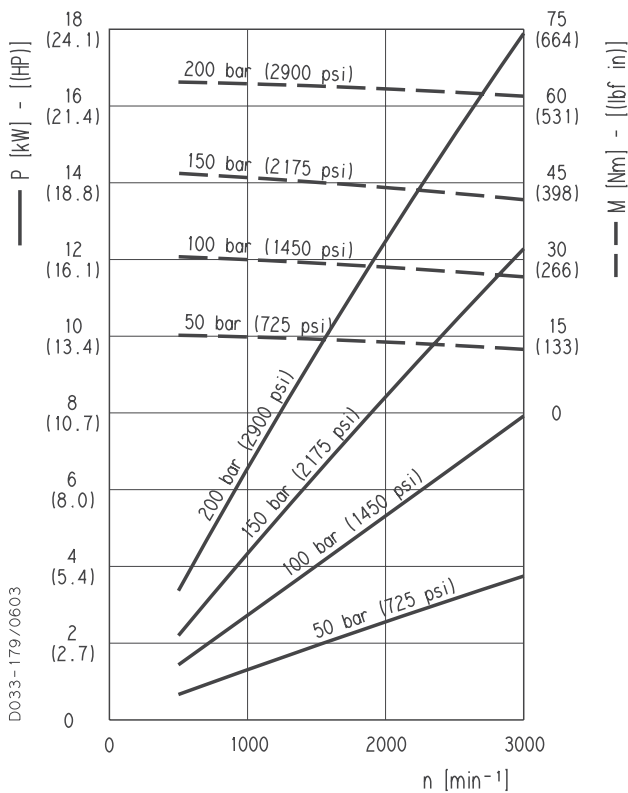

PLM 20•24,5

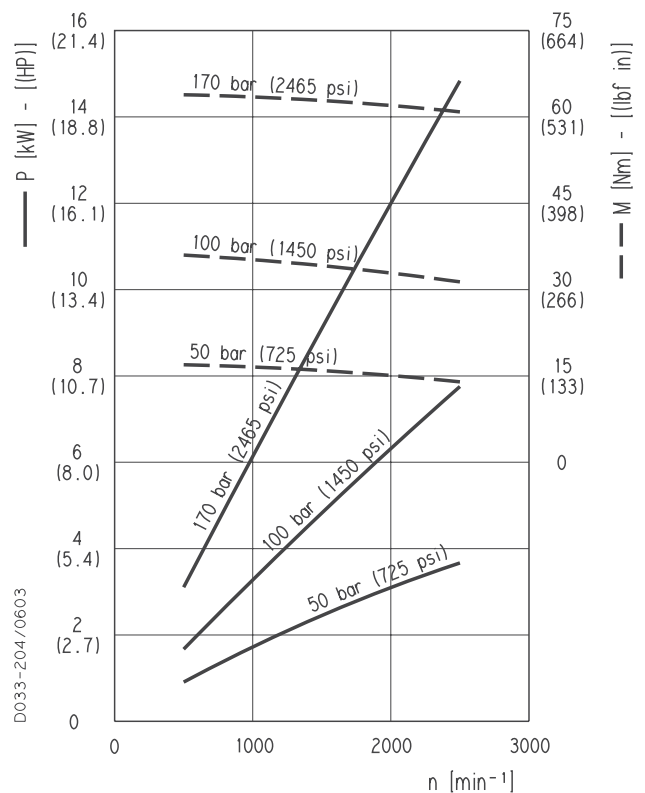

01/10.2003

PLM 20

POLARIS 20 GEAR MOTORS PERFORMANCE CURVES

PLM 20•25

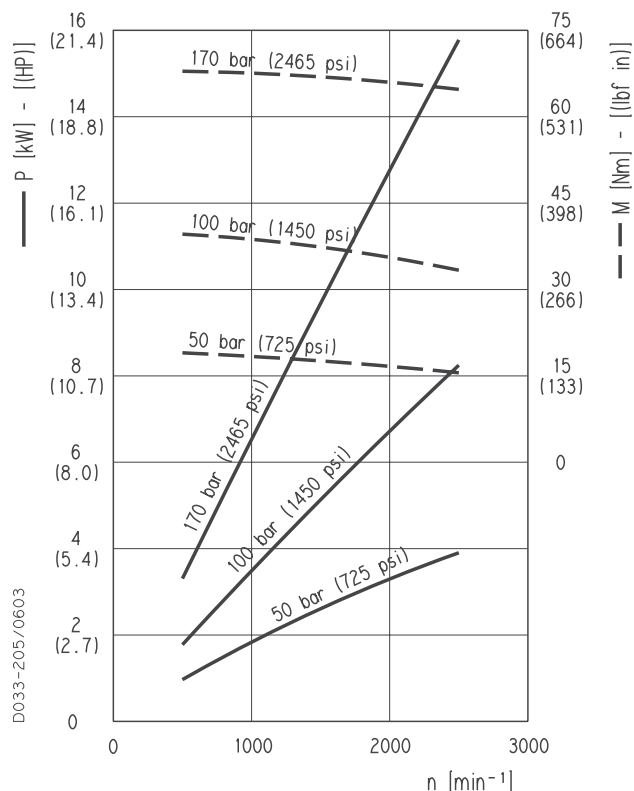

PLM 20•27,8

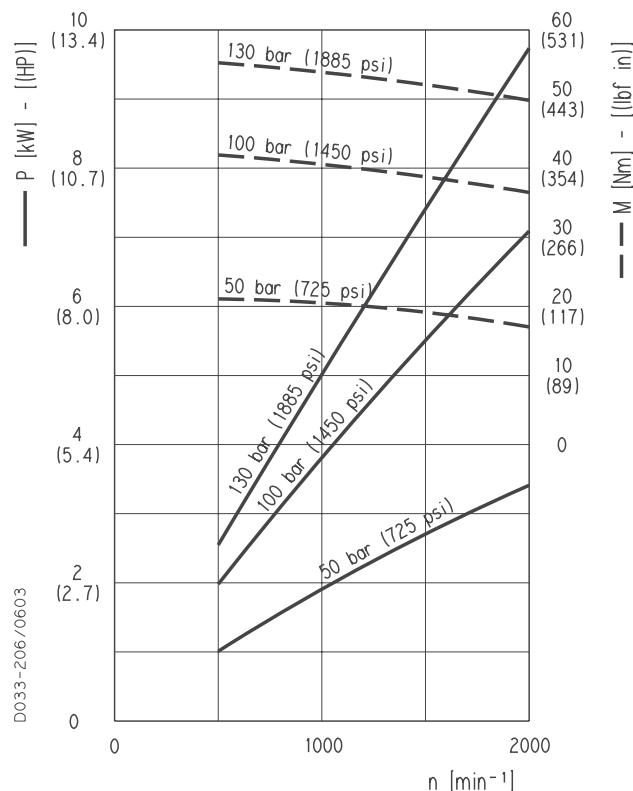

PLM 20•31,5

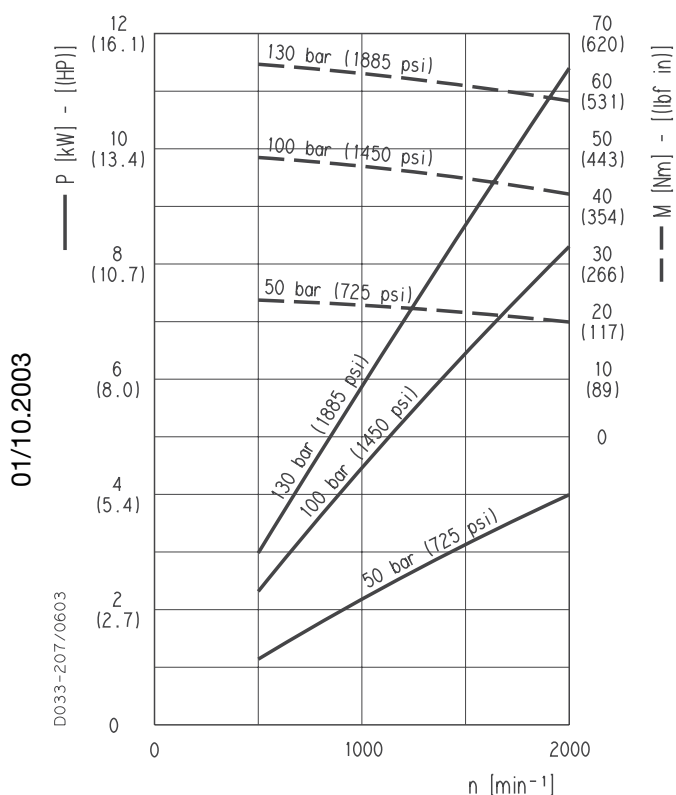

01/10.2003

PLM 30

POLARIS 30 GEAR MOTORS PERFORMANCE CURVES

Each curve has been obtained at 50 °C (122 °F), using oil with viscosity 46 cSt (210 SSU) at 40 °C (104 °F) and at these pressures.

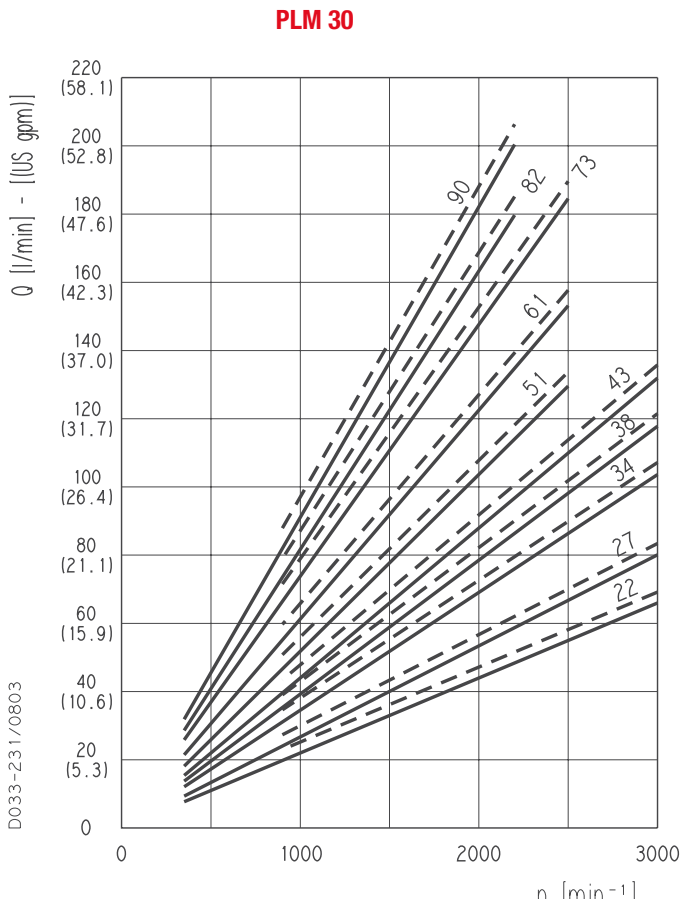

PLM 30•22	—	20 bar (290 psi)
	- - -	250 bar (3625 psi)
PLM 30•27	—	20 bar (290 psi)
	- - -	250 bar (3625 psi)
PLM 30•34	—	20 bar (290 psi)
	- - -	240 bar (3480 psi)
PLM 30•38	—	20 bar (290 psi)
	- - -	240 bar (3480 psi)
PLM 30•43	—	20 bar (290 psi)
	- - -	230 bar (3335 psi)
PLM 30•51	—	20 bar (290 psi)
	- - -	210 bar (3045 psi)
PLM 30•61	—	20 bar (290 psi)
	- - -	190 bar (2775 psi)
PLM 30•73	—	20 bar (290 psi)
	- - -	170 bar (2465 psi)
PLM 30•82	—	20 bar (290 psi)
	- - -	160 bar (2320 psi)
PLM 30•90	—	20 bar (290 psi)
	- - -	150 bar (2175 psi)

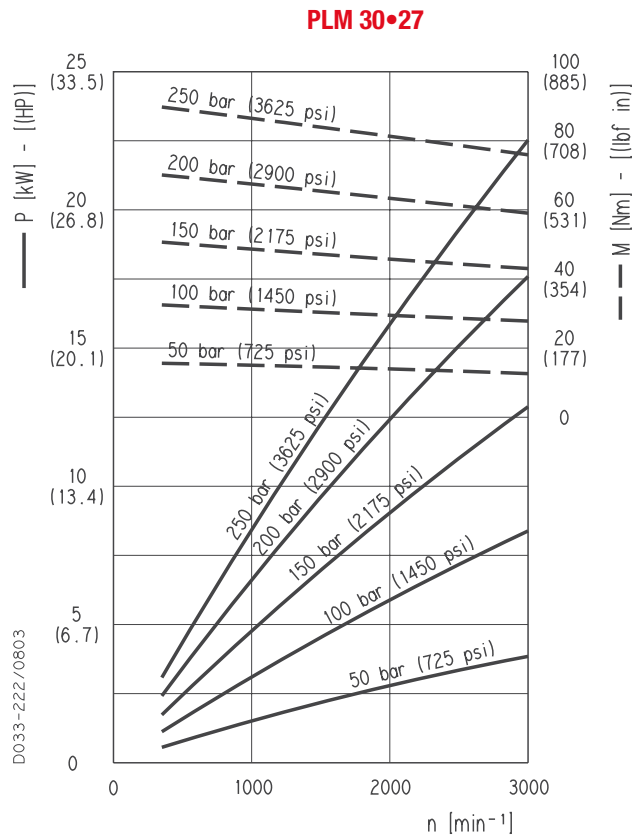
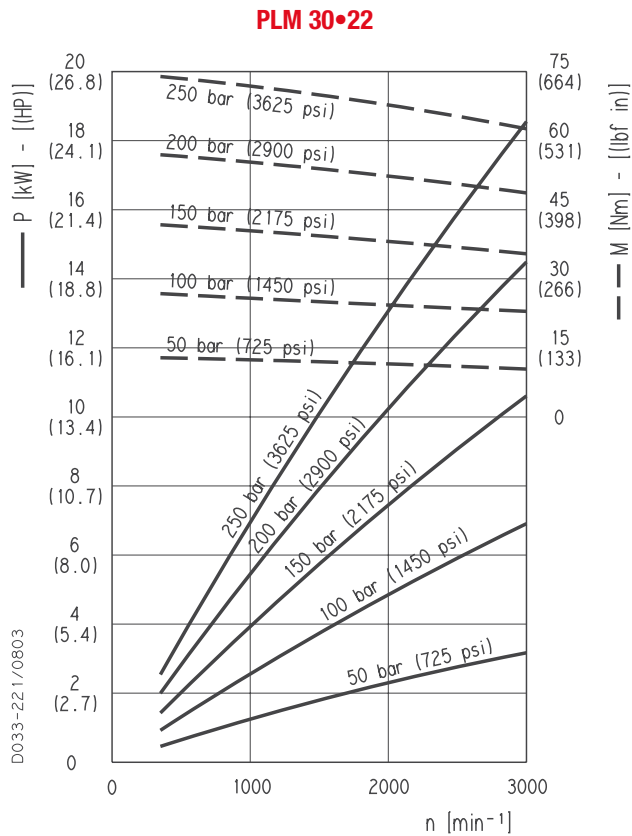

01/10.2003

PLM 30

POLARIS 30 GEAR MOTORS PERFORMANCE CURVES

PLM 30•34

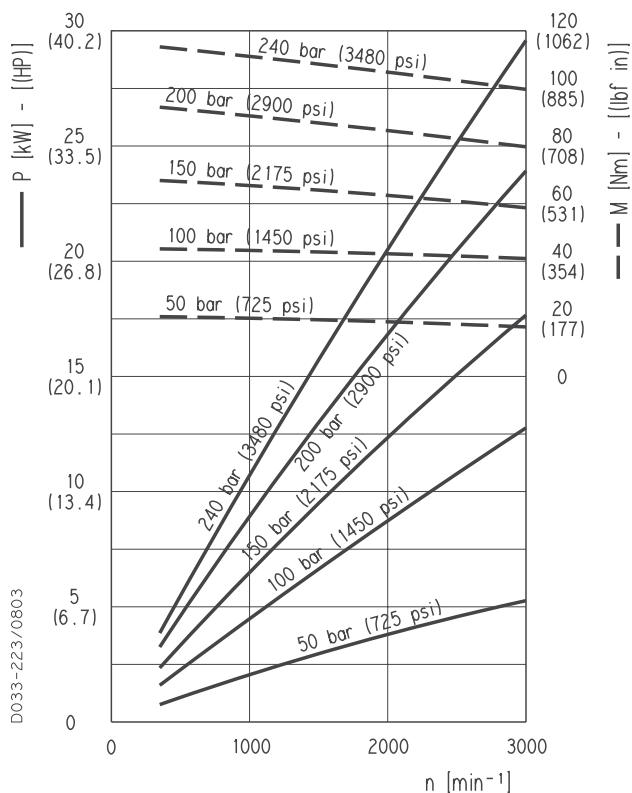

PLM 30•38

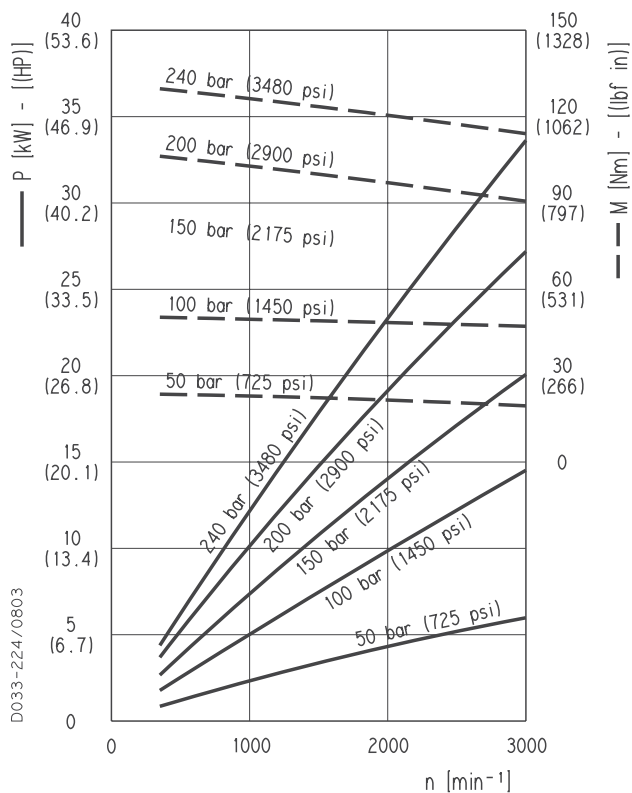

PLM 20•43

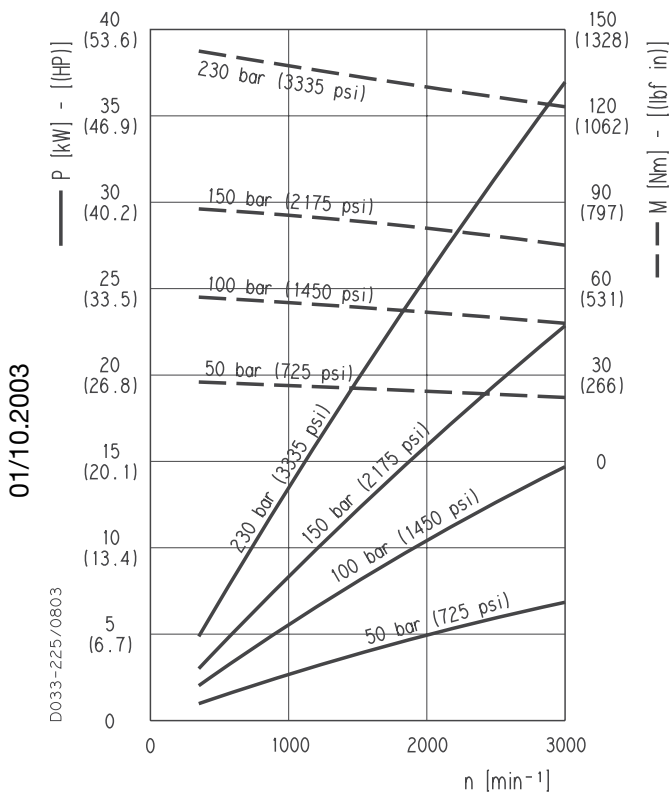

PLM 20•51

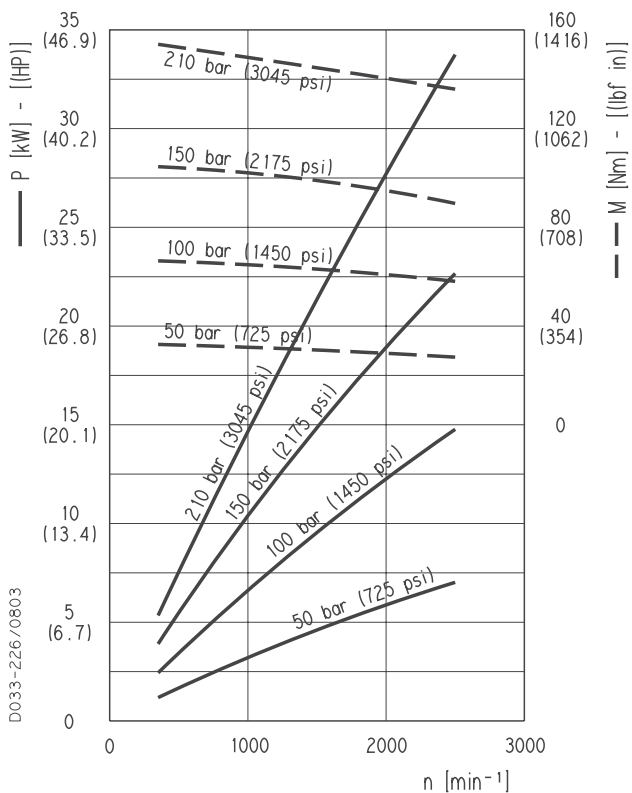

01/10.2003

PLM 30

POLARIS 30 GEAR MOTORS PERFORMANCE CURVES

PLM 30•61

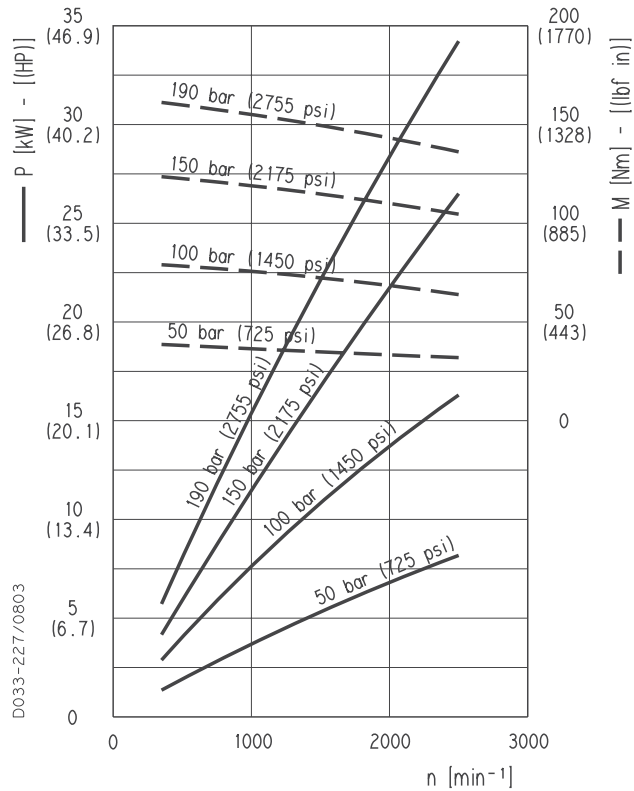

PLM 30•73

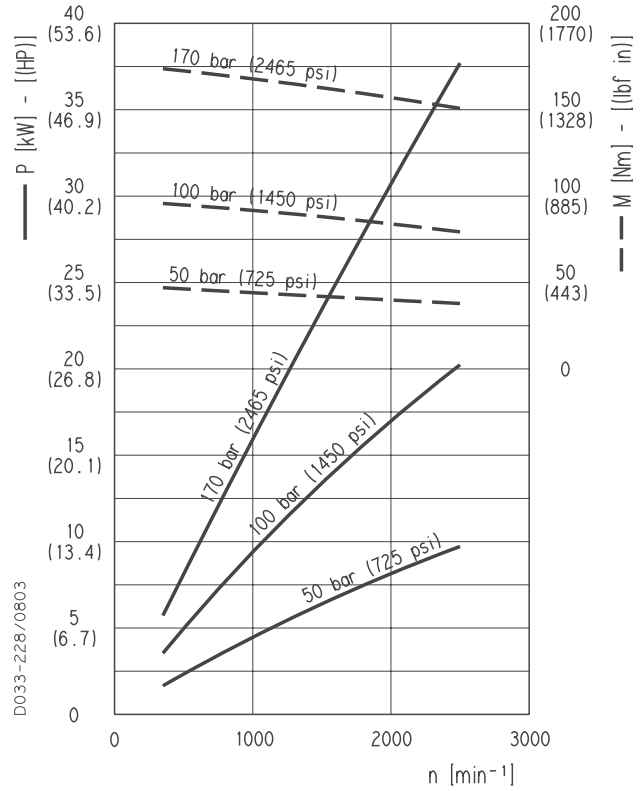

PLM 30•82

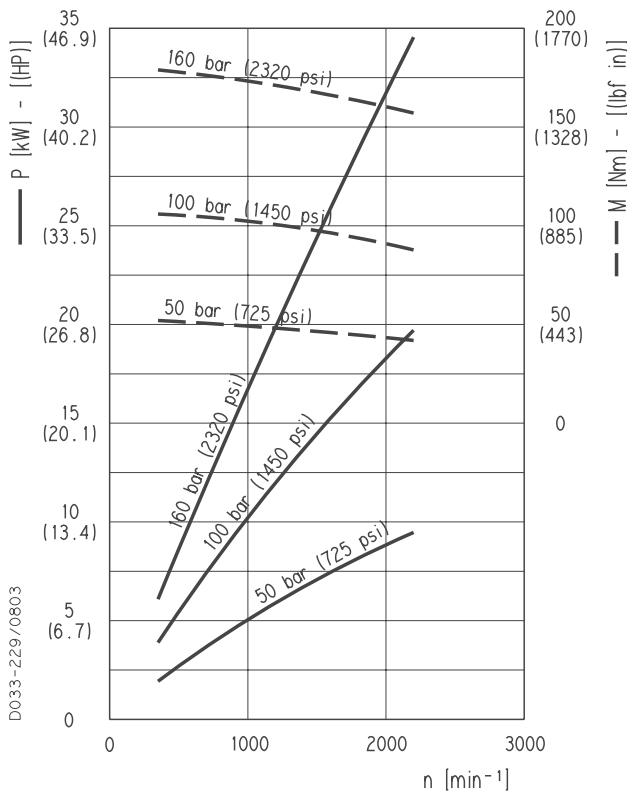

PLM 30•90

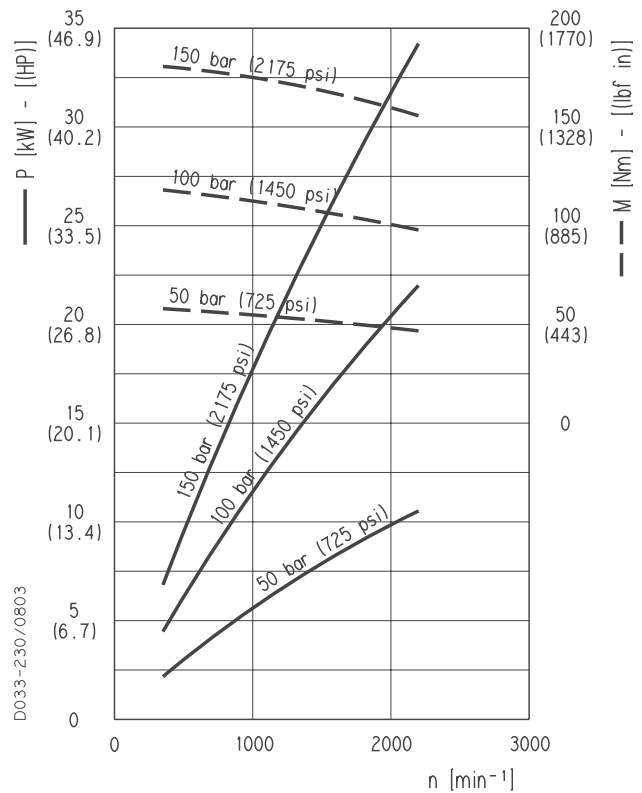

01/10.2003

NOTES

04/10.2020

POLARIS 10

SINGLE UNITS DIMENSIONS - SIDE PORTS

L

Drive shafts: page 52
Mounting flange: for X dimension see page 58 ÷ 60

Ports availability: Gas, SAE, German. See page 70

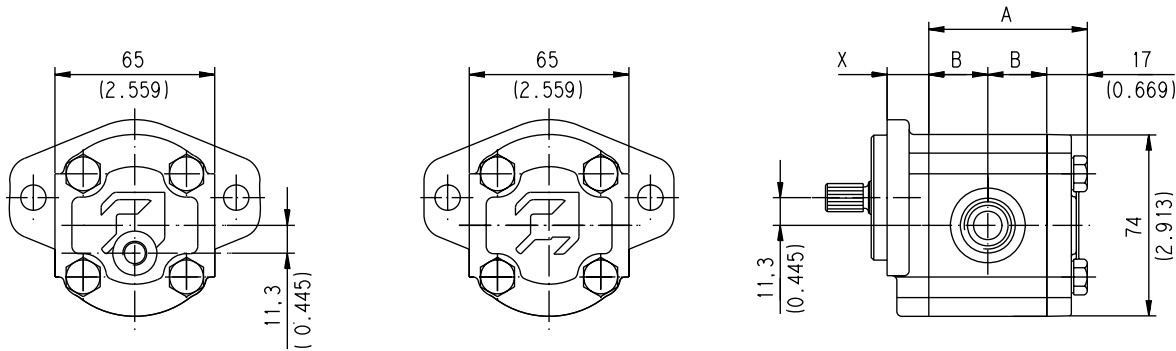

Reversible R

Single rotation S - D

D033-180/0903

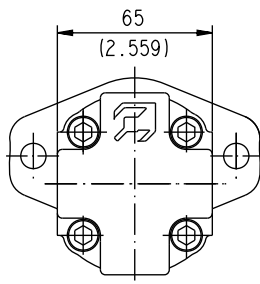

Reversible B

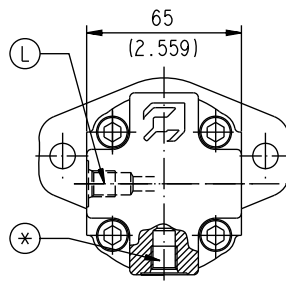

Reversible L

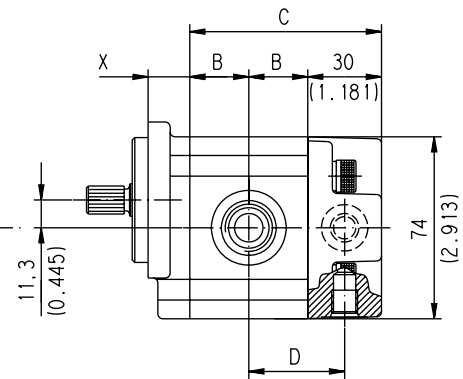
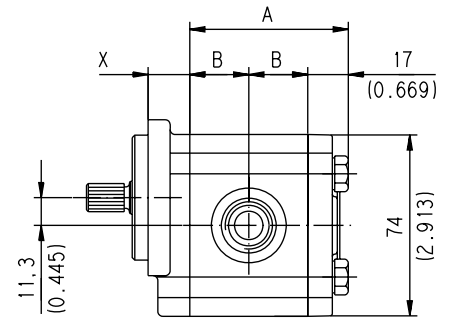

For single rotation S - D and reversible rotation R the rear cover is available in cast iron and aluminium.
For reversible rotation B and L the rear cover is in aluminium only.

Reversible L drain port position:
L = Side
* = Bottom

Pump type Motor type	A	B	C	D
	mm (in)	mm (in)	mm (in)	mm (in)
PL 10•1	52,2 (2.0551)	17,6 (0.6929)	65,2 (2.5669)	32,6 (1.2835)
PL 10•1,5	53,8 (2.1181)	18,4 (0.7244)	66,8 (2.6299)	33,4 (1.3150)
PL 10•2	55,4 (2.1811)	19,2 (0.7559)	68,4 (2.6929)	34,2 (1.3465)
PL 10•2,5	57 (2.2441)	20 (0.7874)	70 (2.7559)	35 (1.3780)
PL 10•3,15	59 (2.3228)	21 (0.8268)	72 (2.8346)	36 (1.4173)
PL 10•4	61,8 (2.4331)	22,4 (0.8819)	74,8 (2.9449)	37,4 (1.4724)
PL 10•5	65 (2.5591)	24 (0.9449)	78 (3.0709)	39 (1.5354)
PL 10•5,8	67,6 (2.6614)	25,3 (0.9961)	80,6 (3.1732)	40,3 (1.5866)
PL 10•6,3	69 (2.7165)	26 (1.0236)	82 (3.2283)	41 (1.6142)
PL 10•8	74,5 (2.9331)	28,75 (1.1319)	87,5 (3.4449)	43,75 (1.7224)
PL 10•10	81 (3.1890)	32 (1.2598)	94 (3.7008)	47 (1.8504)

04/10.2020

POLARIS 10

SINGLE UNITS DIMENSIONS - REAR PORTS

P

Drive shafts: page 52

Ports availability: Gas, SAE

Mounting flange: for X dimension see

See page 70

page 58 ÷ 60

D033-181/0903

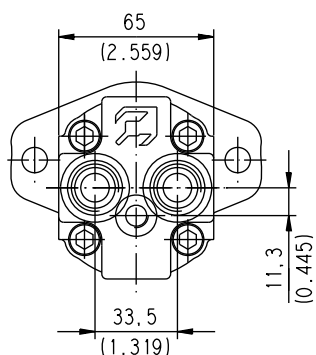

Reversible R

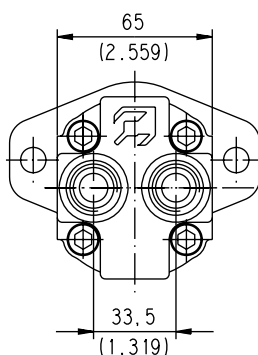

Single rotation S - D

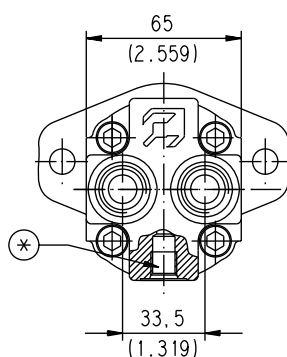

Reversible L

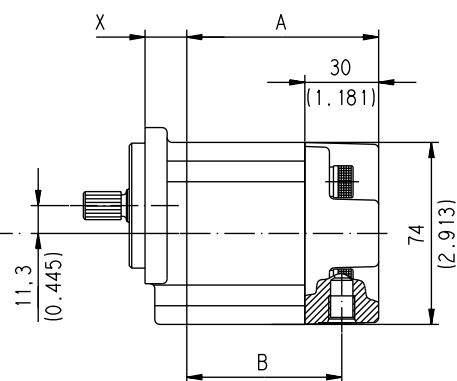
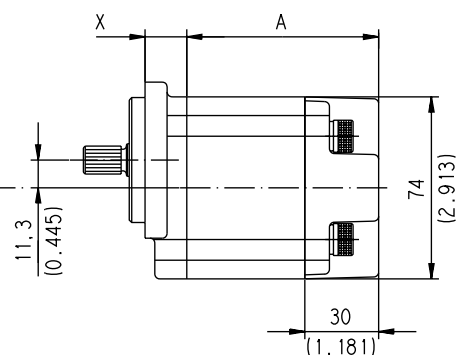

Rear cover in aluminium only.

Reversible L drain port position:

*= Bottom

04/10.2020

Pump type Motor type	A	B
	mm (in)	mm (in)
PL. 10•1	65,2 (2.5669)	50,2 (1.9764)
PL. 10•1,5	66,8 (2.6299)	51,8 (2.0394)
PL. 10•2	68,4 (2.6929)	53,4 (2.0124)
PL. 10•2,5	70 (2.7559)	55 (2.1654)
PL. 10•3,15	72 (2.8346)	57 (2.2441)
PL. 10•4	74,8 (2.9449)	59,8 (2.3543)
PL. 10•5	78 (3.0709)	63 (2.4803)
PL. 10•5,8	80,6 (3.1732)	65,6 (2.5827)
PL. 10•6,3	82 (3.2283)	67 (2.6378)
PL. 10•8	87,5 (3.4449)	72,5 (2.8543)
PL. 10•10	94 (3.7008)	79 (3.1102)

POLARIS 20

SINGLE UNITS DIMENSIONS - SIDE PORTS

L

Drive shafts: page 53 ÷ 55
Mounting flange: for X dimension see page 61 ÷ 66

Ports availability: European, Split, Gas, SAE German. See page 70

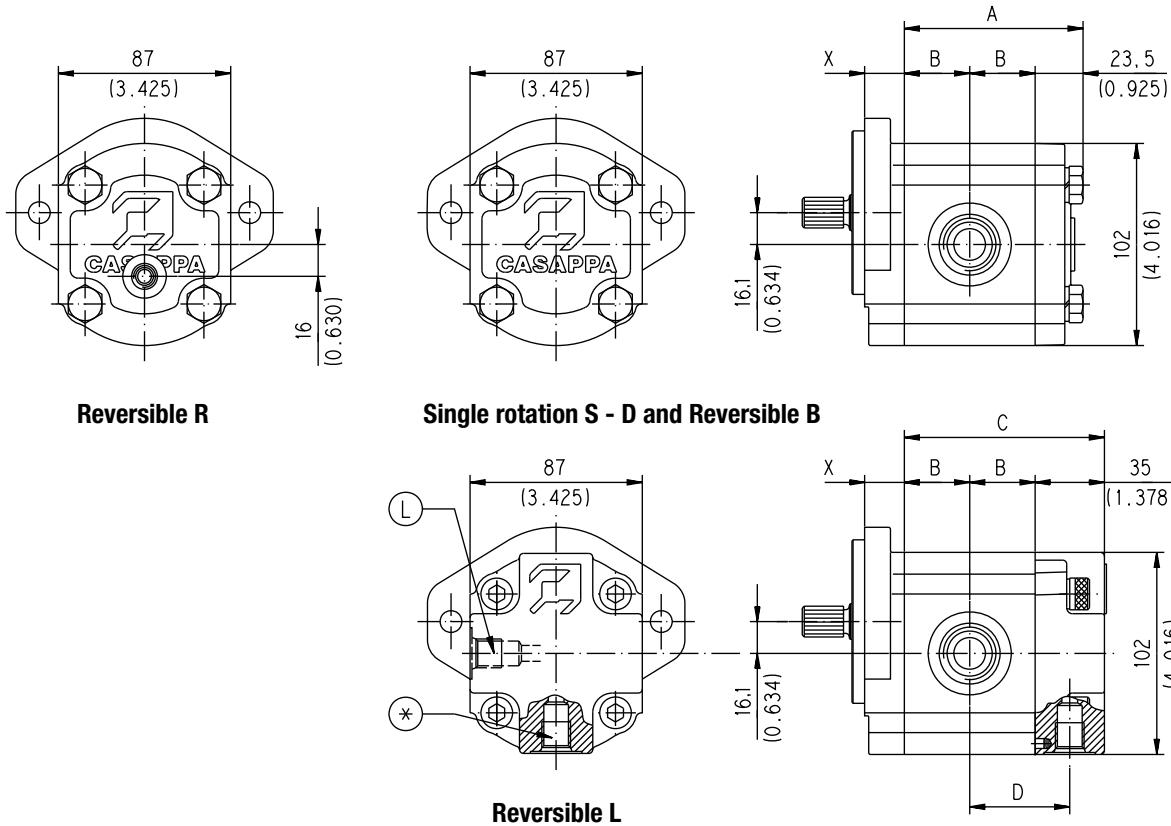

D033-182/0903

For single rotation S - D and reversible B and R the rear cover is available in cast iron and aluminium.
For reversible rotation L the rear cover is in aluminium only.

Reversible L drain port position:
L = Side
* = Bottom

Pump type Motor type	A	B	C	D
	mm (in)	mm (in)	mm (in)	mm (in)
PL. 20•4	75 (2.9528)	25,75 (1.0138)	86,5 (3.4055)	43,25 (1.7028)
PL. 20•6,3	77,5 (3.0512)	27 (1.0630)	89 (3.5039)	44,5 (1.7520)
PL. 20•7,2	78,5 (3.0917)	27,5 (1.083)	90 (3.5445)	45 (1.7722)
PL. 20•8	80 (3.1496)	28,25 (1.1122)	91,5 (3.6024)	45,75 (1.8012)
PL. 20•9	81,3 (3.2008)	28,9 (1.1378)	92,8 (3.6535)	46,4 (1.8268)
PL. 20•10,5	84 (3.3070)	30,25 (1.1909)	95,5 (3.7598)	47,75 (1.8799)
PL. 20•11,2	84,5 (3.3268)	30,5 (1.2008)	96 (3.7795)	48 (1.8898)
PL. 20•14	89,5 (3.5236)	33 (1.2992)	101 (3.9764)	50,5 (1.9882)
PL. 20•16	93 (3.6614)	34,75 (1.3681)	104,5 (4.1142)	52,25 (2.0571)
PL. 20•19	96,4 (3.7952)	36,45 (1.4350)	107,9 (4.2480)	53,9 (2.12)
PL. 20•20	99,5 (3.9173)	38 (1.4961)	111 (4.3701)	55,5 (2.1850)
PL. 20•24,5	105,1 (4.1378)	40,8 (1.6063)	116,6 (4.5905)	58,3 (2.2953)
PL. 20•25	107,5 (4.2323)	42 (1.6535)	119 (4.6850)	59,5 (2.3425)
PL. 20•27,8	110,2 (4.3386)	43,35 (1.7067)	121,7 (4.7913)	60,85 (2.3957)
PL. 20•31,5	117,5 (4.6260)	47 (1.8504)	129 (5.0787)	64,5 (2.5394)

04/10.2020

POLARIS 20

SINGLE UNITS DIMENSIONS - REAR PORTS

P

Drive shafts: page 53 ÷ 55

Ports availability: Gas, SAE.

Mounting flange: for X dimension see page 61 ÷ 66

See page 70

D033-183/0903

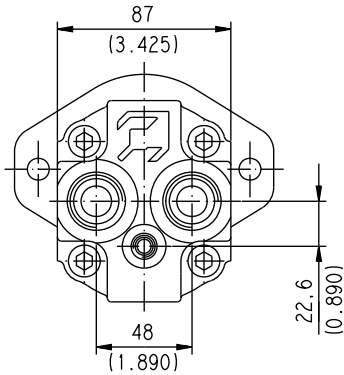

Reversible R

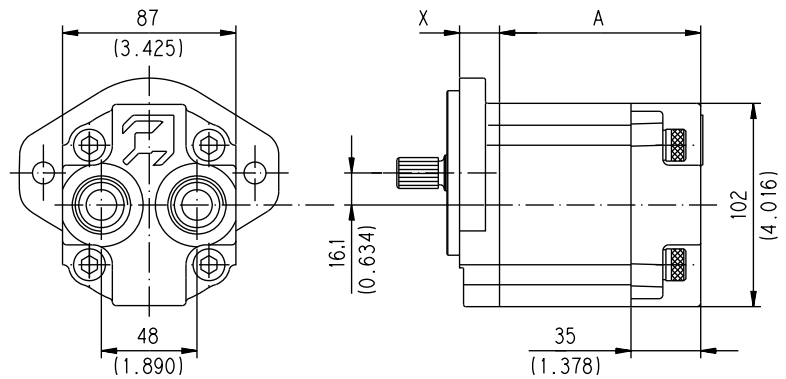

Single rotation S - D and Reversible B

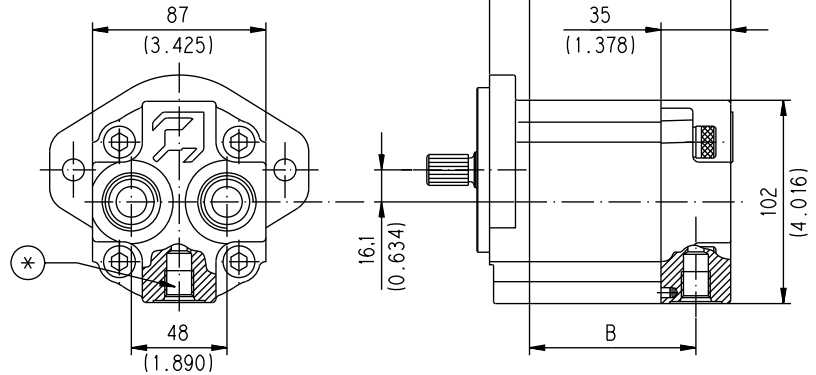

Reversible L

Rear cover in aluminium only.

Reversible L drain port position:

* = Bottom

04/10.2020

Pump type Motor type	A	B
	mm (in)	mm (in)
PL. 20•4	86,5 (3.4055)	69 (2.7165)
PL. 20•6,3	89 (3.5039)	71,5 (2.8150)
PL. 20•7,2	90 (3.5445)	72,5 (2.8555)
PL. 20•8	91,5 (3.6024)	74 (2.9134)
PL. 20•9	92,8 (3.6535)	75,3 (2.9646)
PL. 20•10,5	95,5 (3.7598)	78 (3.0708)
PL. 20•11,2	96 (3.7795)	78,5 (3.0906)
PL. 20•14	101 (3.9764)	83,5 (3.2874)
PL. 20•16	104,5 (4.1142)	87 (3.4252)
PL. 20•19	107,9 (4.2480)	90,4 (3.5591)
PL. 20•20	111 (4.3701)	93,5 (3.6811)
PL. 20•24,5	116,6 (4.5905)	99,1 (3.9016)
PL. 20•25	119 (4.6850)	101,5 (3.9961)
PL. 20•27,8	121,7 (4.7913)	104,2 (4.1024)
PL. 20•31,5	129 (5.0787)	111,5 (4.3898)

POLARIS 30

SINGLE UNITS DIMENSIONS - SIDE PORTS

L

Drive shafts: page 56 ÷ 57

Ports availability: European, Split, Gas,

Mounting flange: for X dimension see
page 67 ÷ 69

SAE German. See page 70

D033-184/0903

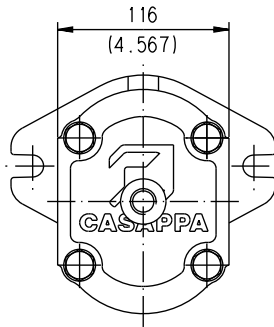

Reversible R

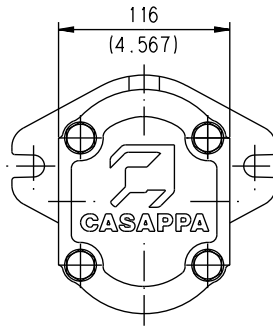

Single rotation S - D

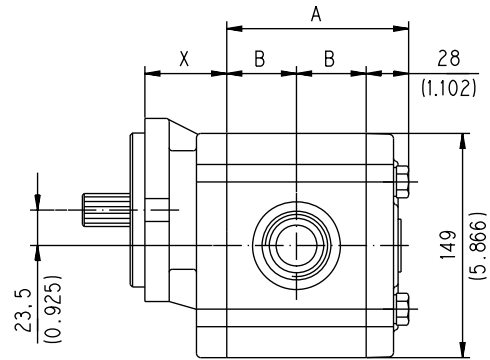

Rear cover in cast iron only.

Pump type Motor type	A	B
	mm (in)	mm (in)
PL. 30•22	106 (4.1732)	39 (1.5354)
PL. 30•27	109 (4.2913)	40,5 (1.5945)
PL. 30•34	114 (4.4882)	43 (1.6929)
PL. 30•38	117 (4.6063)	44,5 (1.7520)
PL. 30•43	120 (4.7244)	46 (1.8110)
PL. 30•51	125 (4.9212)	48,5 (1.9094)
PL. 30•61	131 (5.1575)	51,5 (2.0276)
PL. 30•73	139 (5.4724)	55,5 (2.1850)
PL. 30•82	144 (5.6693)	58 (2.2835)
PL. 30•90	150 (5.9055)	61 (2.4016)

04/10.2020

MULTIPLE PUMPS

POLARIS series pumps can be coupled together in combination. Where the input power requirements of each section varies, that with the greater requirement must be at the drive shaft end, and progressively smaller to the rear.

Replaces: 03/02.2012 Features and performances are the same as the corresponding single pumps, but pressures must be limited by the transmissible torque of the drive and connecting shafts. To have appropriate data, use the formula below.

The maximum rotational speed is that of the lowest rated speed of the single units incorporated.

Available with common inlet and separated stages. For more information please consult our pre-sales department.

M	Nm (lbf in)	Torque
V	cm ³ /rev (in ³ /rev)	Displacement
Δp	bar (psi)	Pressure
$\eta_{hm} = \eta_{hm}(V, \Delta p, n)$		Hydro-mechanical efficiency

$$M = \frac{M_{theor.}}{\eta_{hm}} \quad [Nm]$$

$$M_{theor.} = \frac{\Delta p \text{ (bar)} \cdot V \text{ (cm}^3\text{/rev)}}{62,83} \quad [Nm]$$

NOTE

The torque absorbed from the shaft of the first pump results from the sum of the torques of all the single stages. The achieved value must not exceed the maximum torque limit given for the shaft of the first pump.

05/04.2023

COMMON INLET - PORTS POSITION

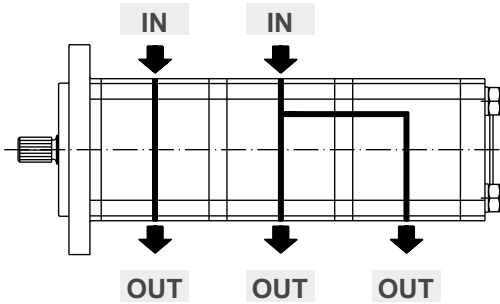
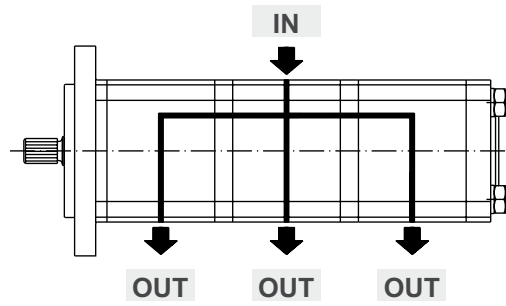
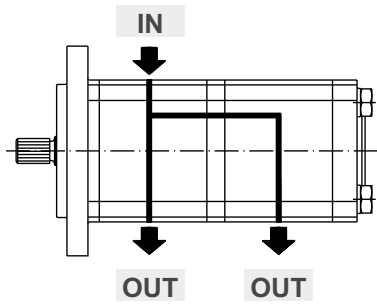

Reduced inlets provide overall systems savings by reducing the cost of redundant inlet hose and fittings.

Please contact us for other combinations.

MULTIPLE PUMPS COMBINATION

PL10

Polaris 10/10	STANDARD VERSION	V6
Polaris 10/10	COMMON INLET VERSION	V7

D033-112/0603

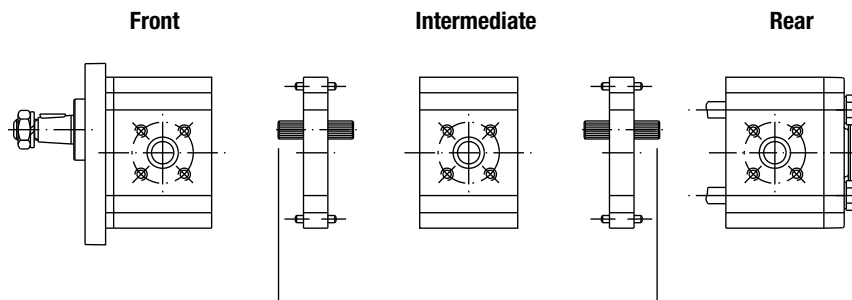

88 MAX 30 Nm (266 lbf in)

88 MAX 30 Nm (266 lbf in)

02/07.2006

MULTIPLE PUMPS COMBINATION

PLP 20

Polaris 20/20	STANDARD VERSION	S6
Polaris 20/20	COMMON INLET VERSION	S7

D033-106/0603

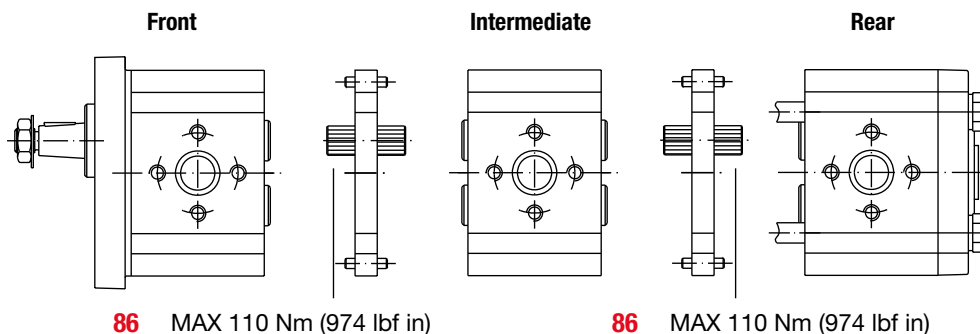

Polaris 20/20	SEPARATED SRAGES VERSION	Z6
----------------------	---------------------------------	-----------

D033-110/0603

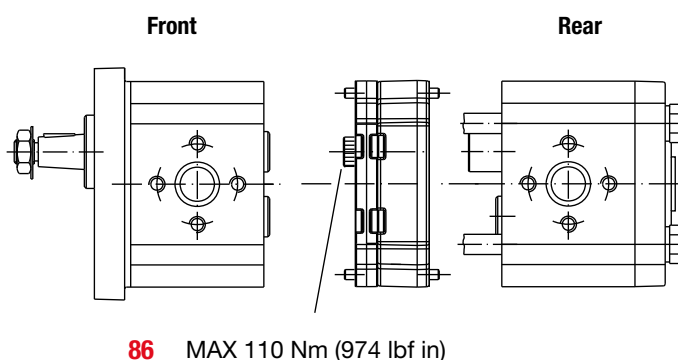

Polaris 20/10	STANDARD VERSION	T6
Polaris 20/10	COMMON INLET VERSION	T7

D033-107/0603

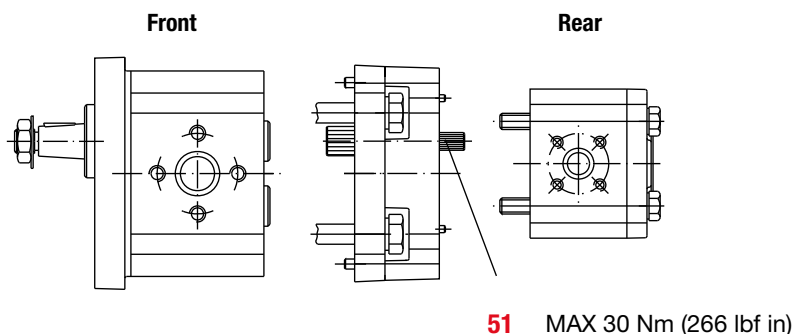

Polaris 20/10	SEPARATED SRAGES VERSION	Z6
----------------------	---------------------------------	-----------

D033-111/0603

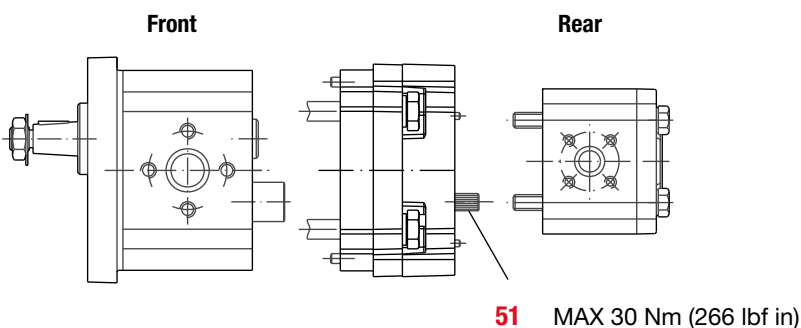

04/10.2020

MULTIPLE PUMPS COMBINATION

PLP 30

Polaris 30/30

STANDARD VERSION

M6

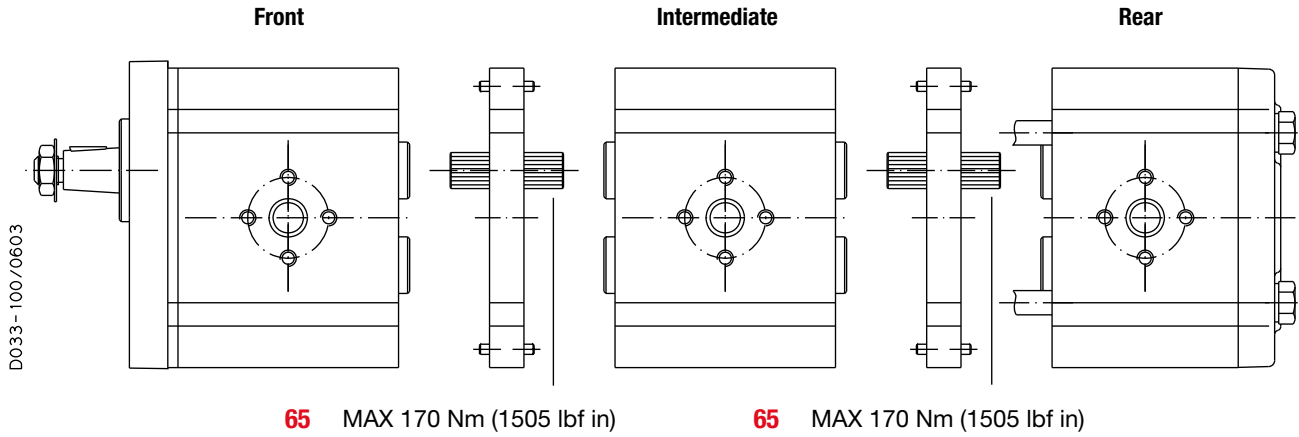

Polaris 30/20

STANDARD VERSION

N6

Polaris 30/20

COMMON INLET VERSION

N7

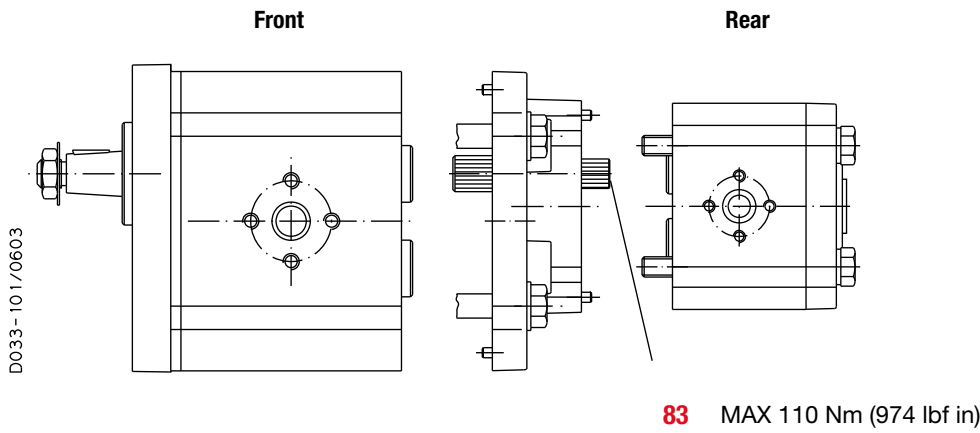

Polaris 30/20

SEPARATED SRAGES VERSION

Z6

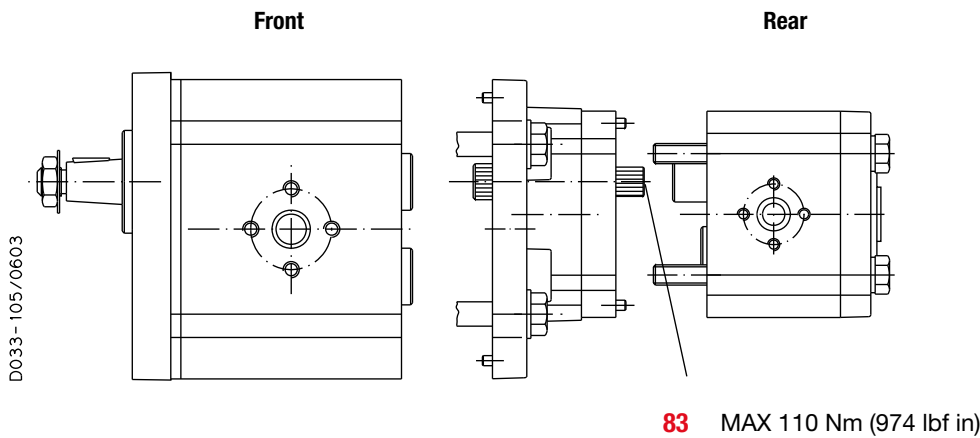

04/10.2020

MULTIPLE PUMPS COMBINATION

PLP 30

Polaris 30/20	STANDARD VERSION	Q6
Polaris 30/10	COMMON INLET VERSION	Q7

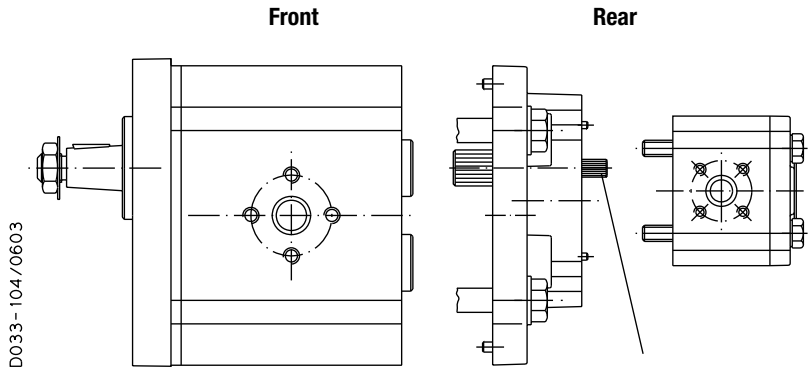

52 MAX 30 Nm (266 lbf in)

02/07.2006

POLARIS 10

MULTIPLE PUMPS DIMENSIONS

PLP10

Drive shafts: page 52
Mounting flange: for X dimension see page 58 ÷ 60

Ports availability: Gas, SAE, German. See page 70

PLP 10/10

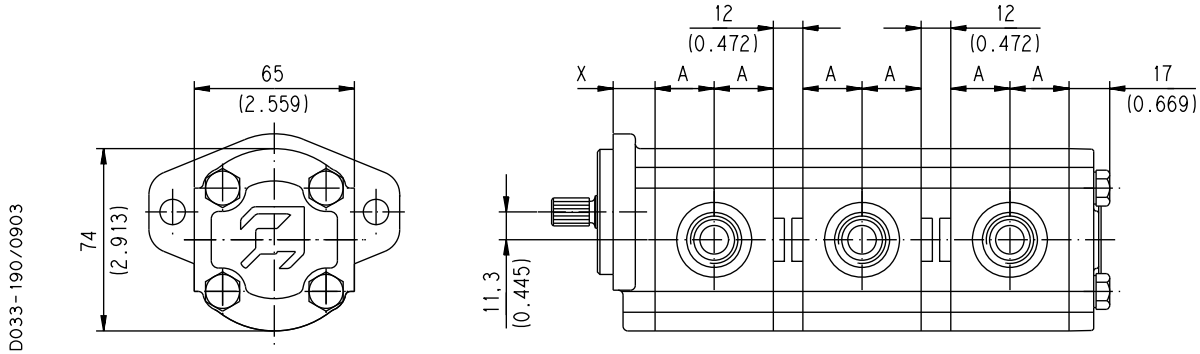

Rear cover available in cast iron and aluminium.

Pump type	A
	mm (in)
PLP. 10•1	17,6 (0.6929)
PLP. 10•1,5	18,4 (0.7244)
PLP. 10•2	19,2 (0.7559)
PLP. 10•2,5	20 (0.7874)
PLP. 10•3,15	21 (0.8268)
PLP. 10•4	22,4 (0.8819)
PLP. 10•5	24 (0.9449)
PLP. 10•5,8	25,3 (0.9961)
PLP. 10•6,3	26 (1.0236)
PLP. 10•8	28,7 (1.1319)
PLP. 10•10	32 (1.2598)

04/10.2020

POLARIS 20

MULTIPLE PUMPS DIMENSIONS

PLP 20

Drive shafts: page 53 ÷ 55
Mounting flange: for X dimension see page 61 ÷ 65

Ports availability: European, Split, Gas, SAE German. See page 70

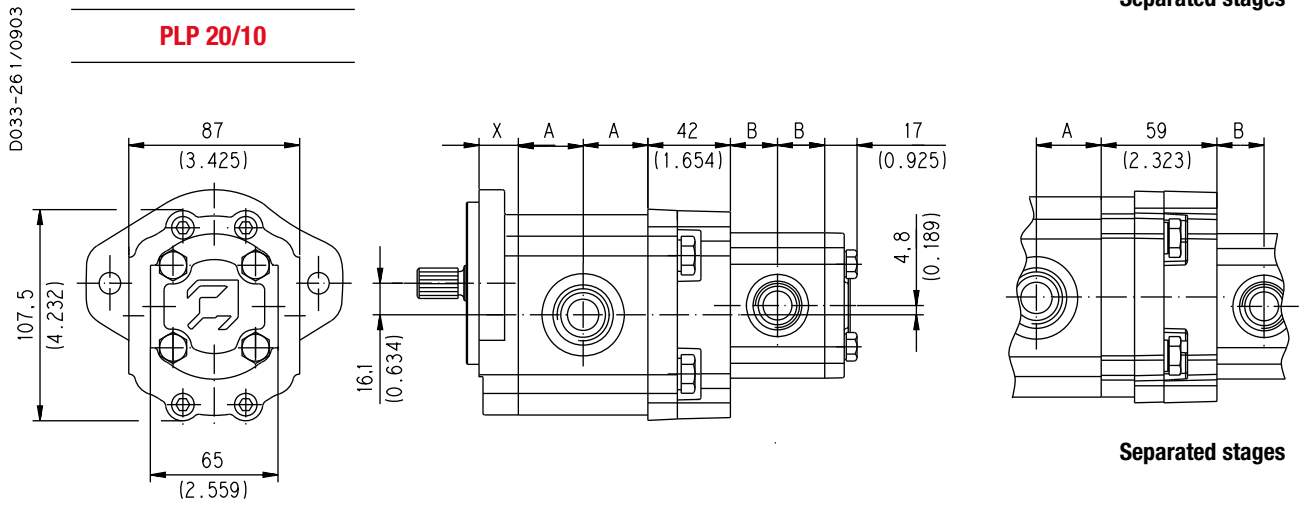
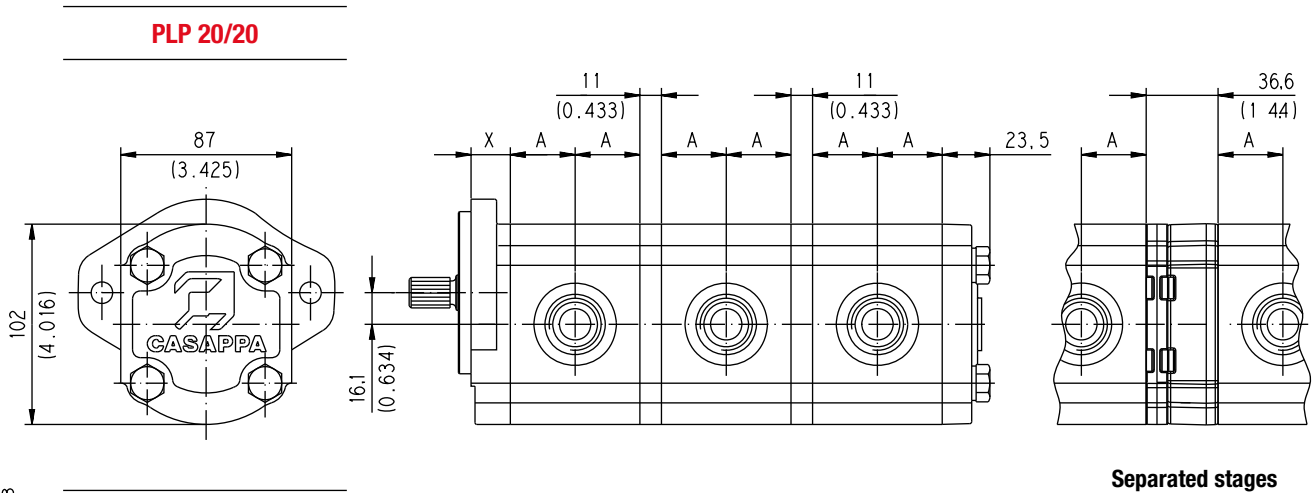

Pump type	A mm (in)
PLP 20•4	25,75 (1.0138)
PLP 20•6,3	27 (1.0630)
PLP 20•7,2	27,5 (1.0827)
PLP 20•8	28,25 (1.1122)
PLP 20•9	28,9 (1.1378)
PLP 20•10,5	30,25 (1.1909)
PLP 20•11,2	30,5 (1.2008)
PLP 20•14	33 (1.2992)
PLP 20•16	34,75 (1.3681)
PLP 20•19	36,45 (1.4350)
PLP 20•20	38 (1.4961)
PLP 20•24,5	40,8 (1.6063)
PLP 20•25	42 (1.6535)
PLP 20•27,5	43,35 (1.7067)
PLP 20•31,5	47 (1.8504)

Rear cover available in cast iron and aluminium.

Pump type	B mm (in)
PLP 10•1	17,6 (0.6929)
PLP 10•1,5	18,4 (0.7244)
PLP 10•2	19,2 (0.7559)
PLP 10•2,5	20 (0.7874)
PLP 10•3,15	21 (0.8268)
PLP 10•4	22,4 (0.8819)
PLP 10•5	24 (0.9449)
PLP 10•5,8	25,3 (0.9961)
PLP 10•6,3	26 (1.0236)
PLP 10•8	28,75 (1.1319)
PLP 10•10	32 (1.2598)

04/10.2020

POLARIS 30

MULTIPLE PUMPS DIMENSIONS

PLP30

Drive shafts: page 56 ÷ 57
Mounting flange: for X dimension see page 67 ÷ 69

Ports availability: European, Split, Gas, SAE German. See page 70

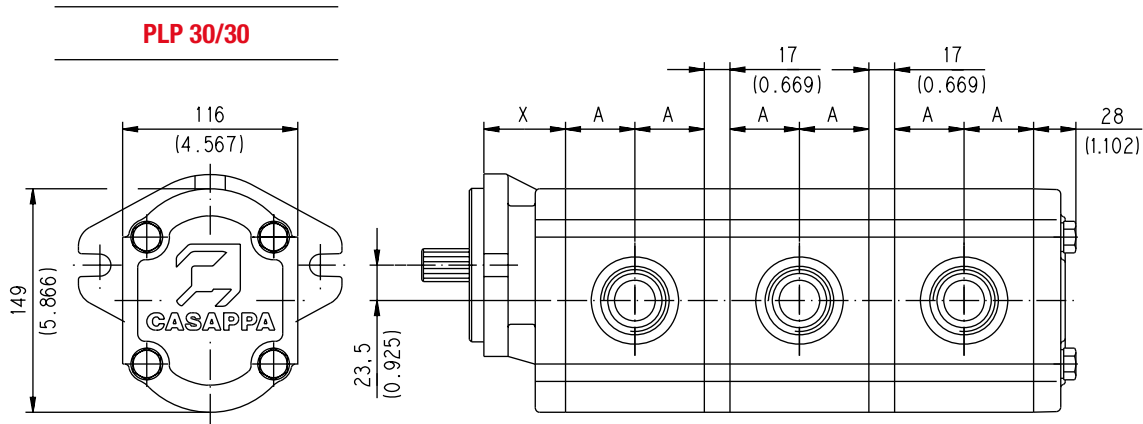

Rear cover in cast iron only.

PLP 30/20

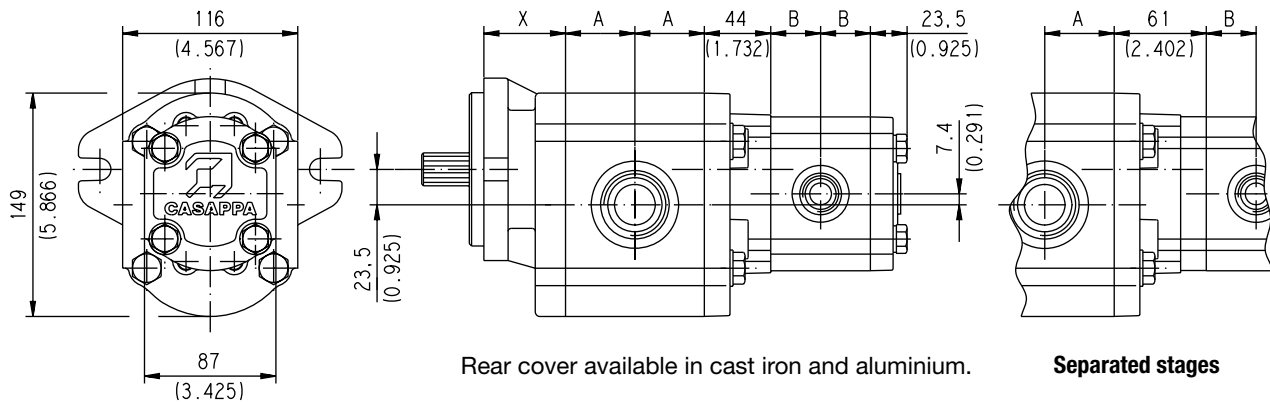

Rear cover available in cast iron and aluminium.

Separated stages

PLP 30/10

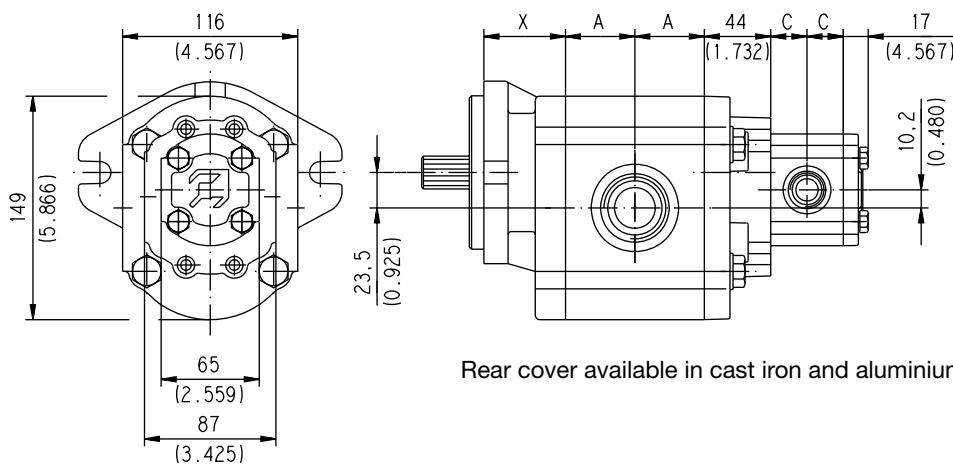

Rear cover available in cast iron and aluminium.

D033-260/0903

04/10.2020

POLARIS 30
MULTIPLE PUMPS DIMENSIONS
PLP30

Pump type	A
	mm (inch)
PLP 30•22	39 (1.5354)
PLP 30•27	40,5 (1.5945)
PLP 30•34	43 (1.6929)
PLP 30•38	44,5 (1.7520)
PLP 30•43	46 (1.8110)
PLP 30•51	48,5 (1.9094)
PLP 30•61	51,5 (2.0276)
PLP 30•73	55,5 (2.1850)
PLP 30•82	58 (2.2835)
PLP 30•90	61 (2.4016)

Pump type	B
	mm (inch)
PLP 20•4	25,75 (1.0138)
PLP 20•6,3	27 (1.0630)
PLP 20•7,2	27,5 (1.0827)
PLP 20•8	28,25 (1.1122)
PLP 20•9	28,9 (1.1378)
PLP 20•10,5	30,25 (1.1909)
PLP 20•11,2	30,5 (1.2008)
PLP 20•14	33 (1.2992)
PLP 20•16	34,75 (1.3681)
PLP 20•19	36,45 (1.4350)
PLP 20•20	38 (1.4961)
PLP 20•24,5	40,8 (1.6063)
PLP 20•25	42 (1.6535)
PLP 20•27,5	43,35 (1.7067)
PLP 20•31,5	47 (1.8504)

Pump type	C
	mm (inch)
PLP 10•1	17,6 (0.6929)
PLP 10•1,5	18,4 (0.7244)
PLP 10•2	19,2 (0.7559)
PLP 10•2,5	20 (0.7874)
PLP 10•3,15	21 (0.8268)
PLP 10•4	22,4 (0.8819)
PLP 10•5	24 (0.9449)
PLP 10•5,8	25,3 (0.9961)
PLP 10•6,3	26 (1.0236)
PLP 10•8	28,75 (1.1319)
PLP 10•10	32 (1.2598)

02/07.2006

OUTBOARD BEARING OPTIONS

For each version, the possible combination between drive shafts and mounting flanges are shown on pages 58 ÷ 69. For the outboard bearing life expectancy, diagrams providing approximate selection data will be found on subsequent pages. Please contact us for particular applications.

PLP 10 - 20 - 30

VERSION

0

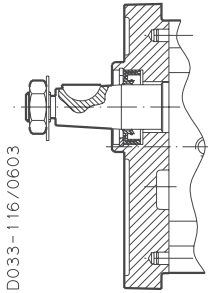

Version for applications without radial and axial load on the drive shaft.

PLP20 VERSION

W8

Only available in 55 W8

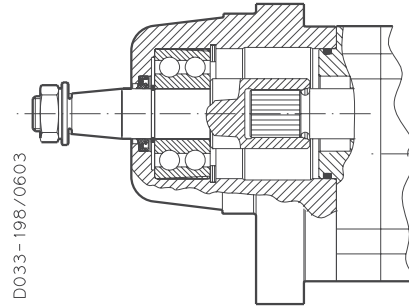

PLP20 VERSION

5

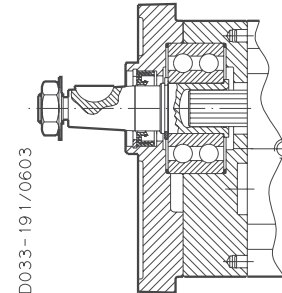

PLP20 VERSION

7

Only available in 82 E2

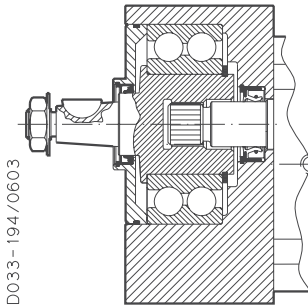

PLP20 VERSION

8

Only available in B1 E2

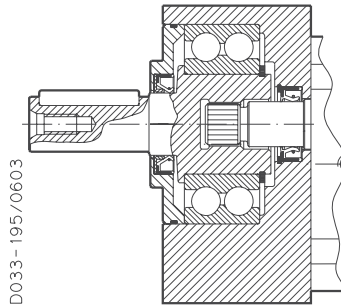

PLP20 VERSION

9

Only available in 55 B2

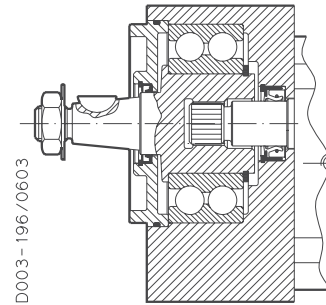

04/10.2020

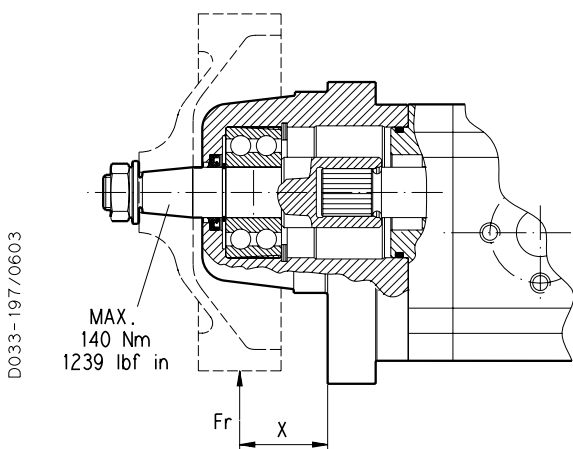

X = Distance of the radial load result from the mounting flange [mm (in)].

Each curve has been obtained at:

- Lubricant oil ISO VG 46
- Temperature 60 °C (140 °F)
- Without axial load
- Contamination level according ISO 281: $\beta_{12}(C) = 200$
- Reliability level of the calculation 90%

Example

Fr Radial load	1900 N (427.5 lbf)
X	20 mm (0.79 in)
Speed	2000 min ⁻¹
Rated fatigue life	≈ 3050 h

Values shown in the diagrams are indicative only. Please contact us for more information.

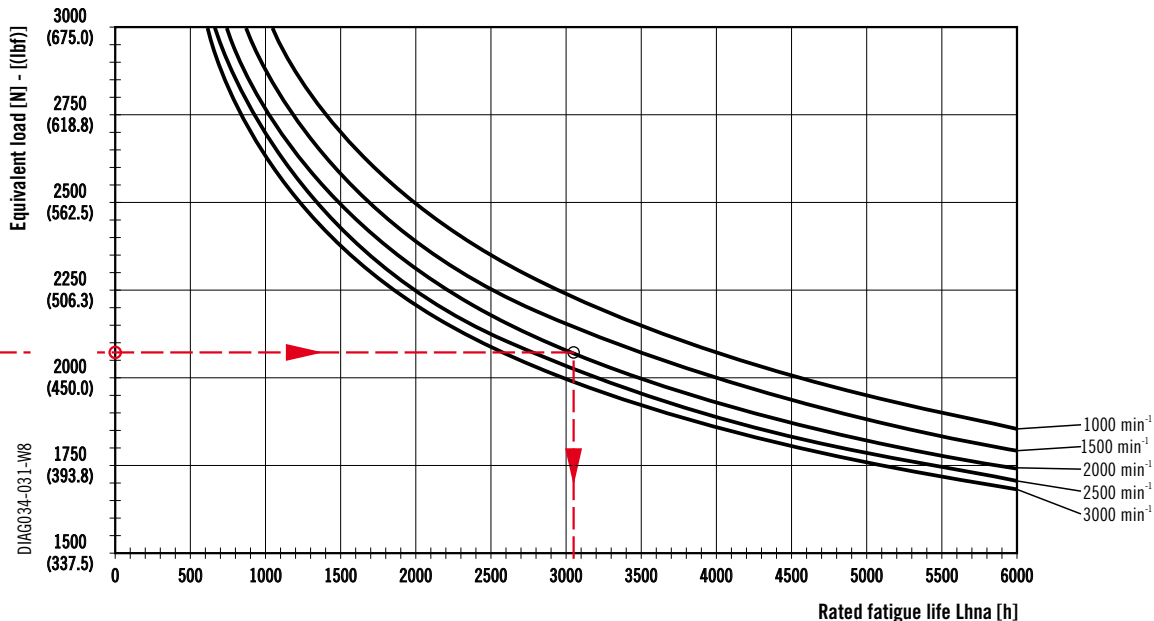
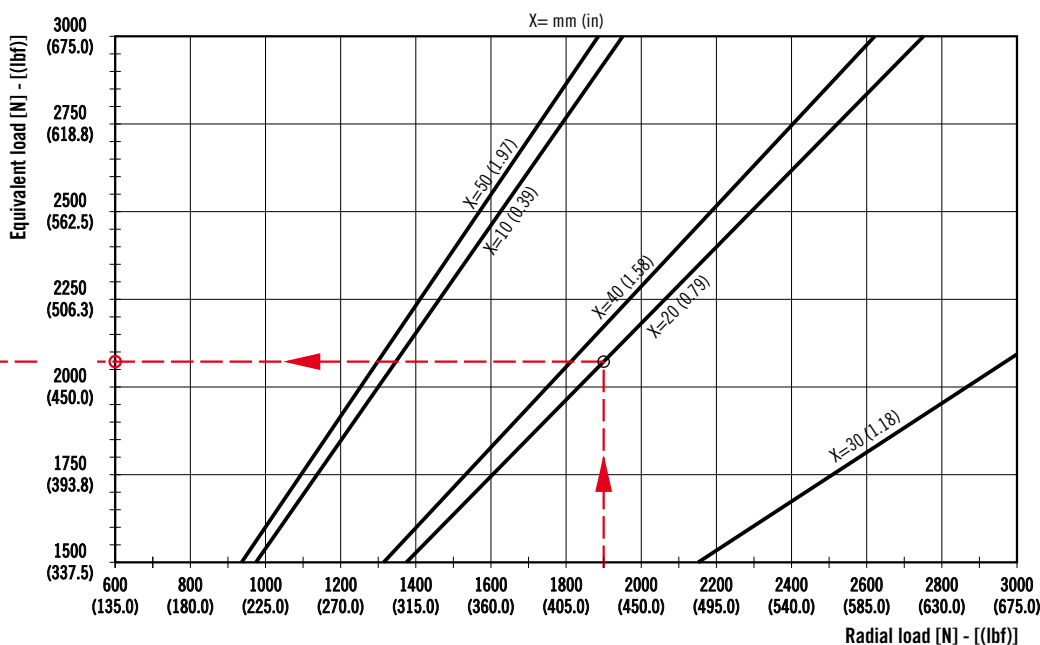

02/07.2006

DIAG034-031-W8

D033-115/0603

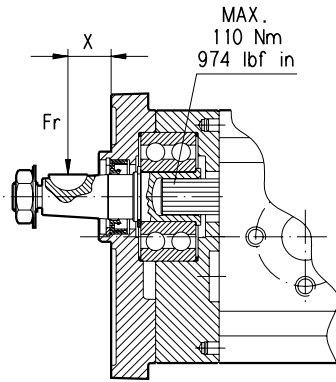

X = Distance of the radial load result from the mounting flange [mm (in)].

Each curve has been obtained at:

- Lubricant oil ISO VG 46
- Temperature 60 °C (140 °F)
- Without axial load
- Contamination level according ISO 281: $\beta_{12}(C) = 200$
- Reliability level of the calculation 90%

Example

Fr Radial load	850 N (191.3 lbf)
X	20 mm (0.79 in)
Speed	2000 min ⁻¹
Rated fatigue life	≈ 2100 h

Values shown in the diagrams are indicative only. Please contact us for more information.

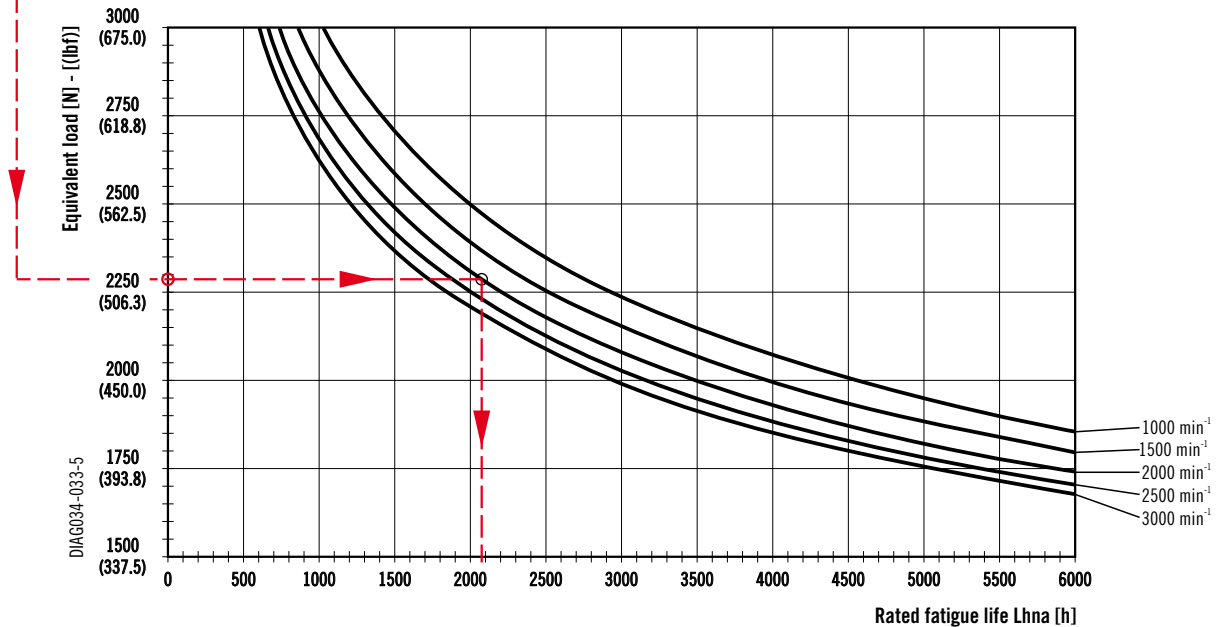
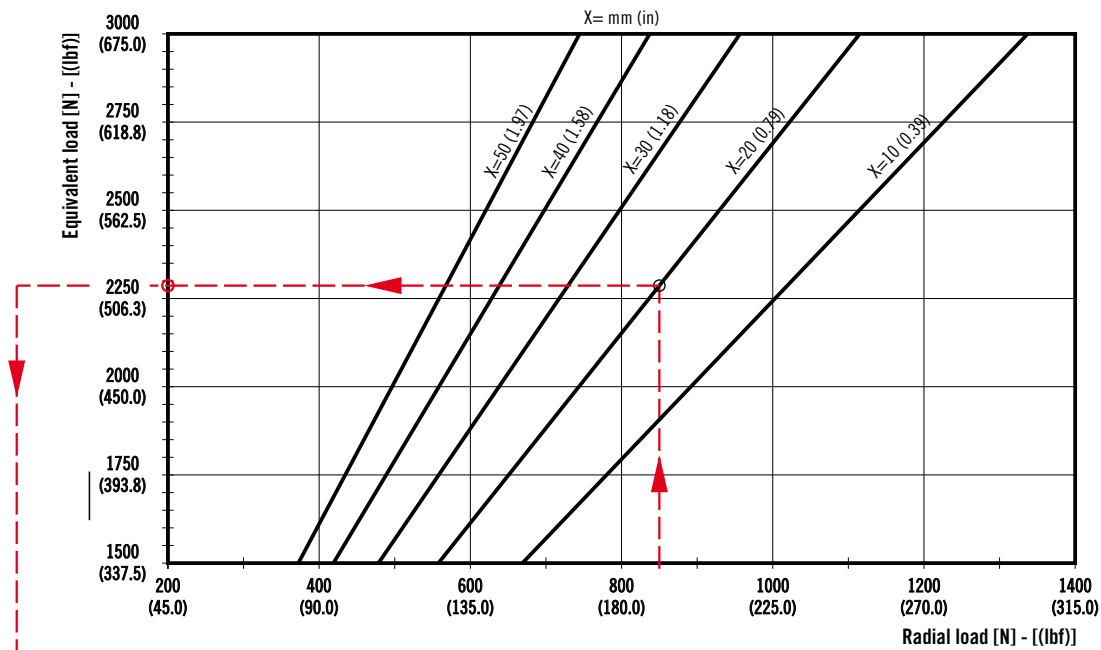

04/10.2020

D033-118/0603

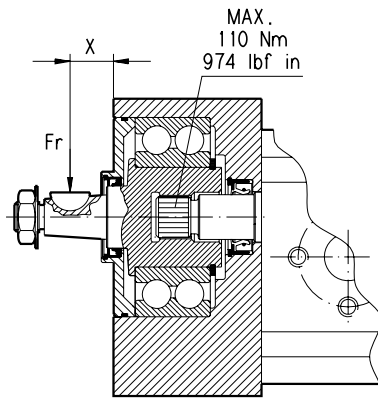

X = Distance of the radial load result from the mounting flange [mm (in)].

Each curve has been obtained at:

- Lubricant oil ISO VG 46
- Temperature 60 °C (140 °F)
- Without axial load
- Contamination level according ISO 281: $\beta_{12}(C) = 200$
- Reliability level of the calculation 90%

Example

Fr Radial load	1900 N (427.5 lbf)
X	20 mm (0.79 in)
Speed	2000 min ⁻¹
Rated fatigue life	≈ 4600 h

Values shown in the diagrams are indicative only.
Please contact us for more information.

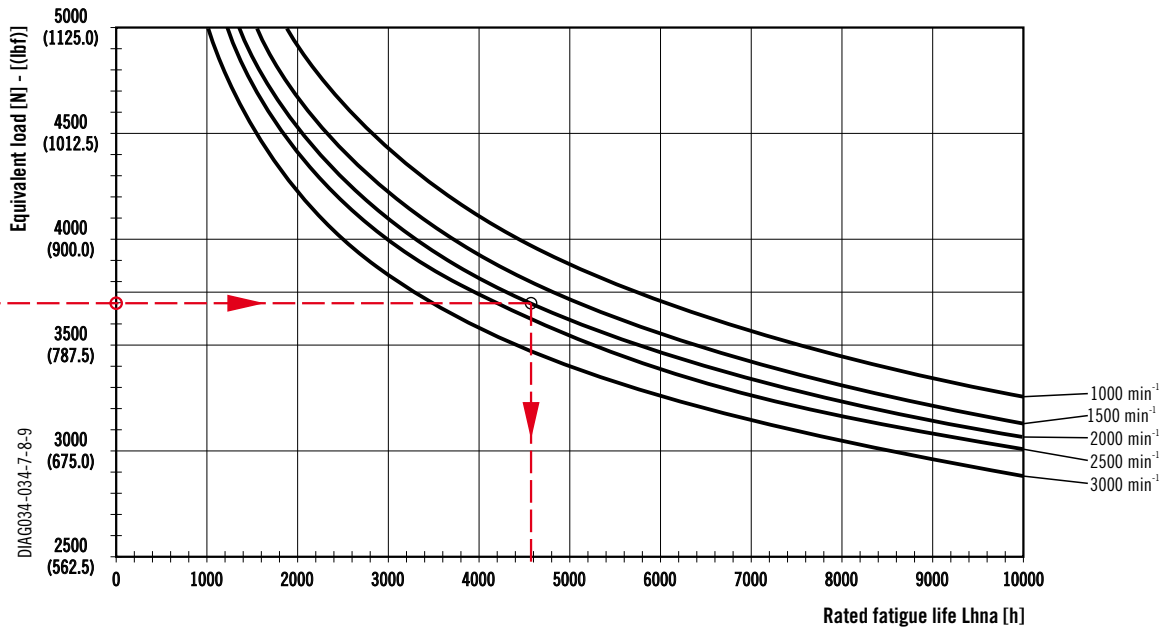
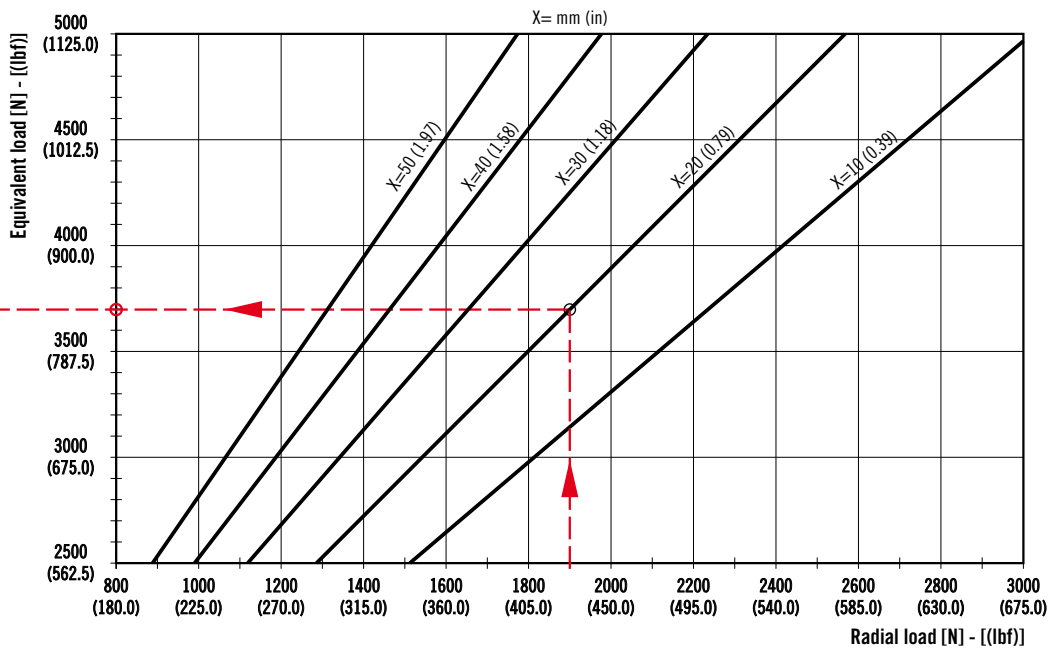

04/10.2020

DIA G034-034-7-8-9

POLARIS 10

DRIVE SHAFTS

EUROPEAN TAPERED 1:8

81

Mounting face refer to flange code **E1**

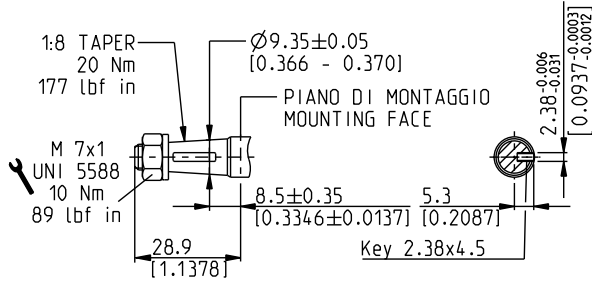

DCAT_033_041

EUROPEAN TAPERED 1:8

86

Mounting face refer to flange code **E7**

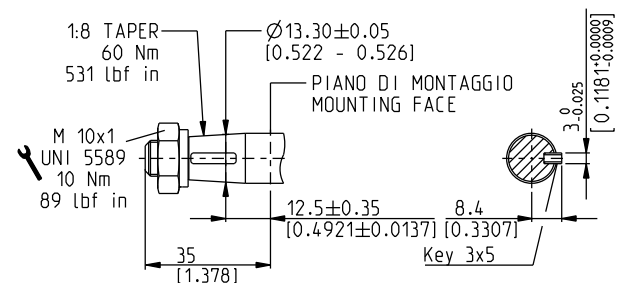

DCAT_033_042

SAE "AA" SPLINE

02

Mounting face refer to flange code **R9**

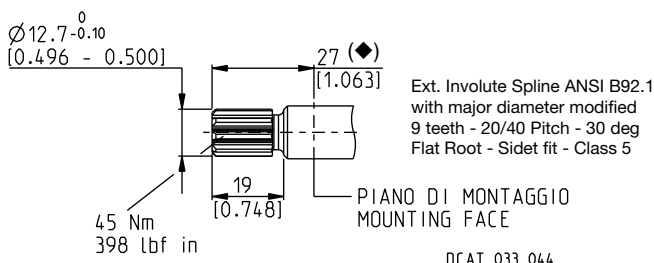

DCAT_033_044

(◆) 24 (0.9449) with flange code **S0**

SAE "AA" STRAIGHT

30

Mounting face refer to flange code **S0**

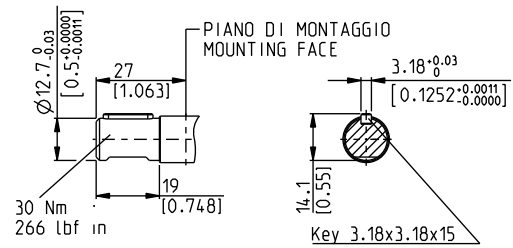

DCAT_033_045

SAE STRAIGHT

36

Not available with size:

10•1,5 10•2,5

Mounting face refer to flange code **R8**

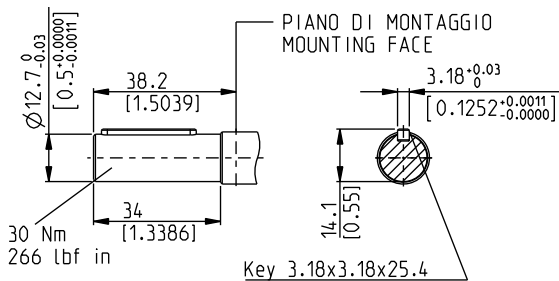

DCAT_033_046

STRAIGHT

29

Not available with size:

10•5,8

Mounting face refer to flange code **E8**

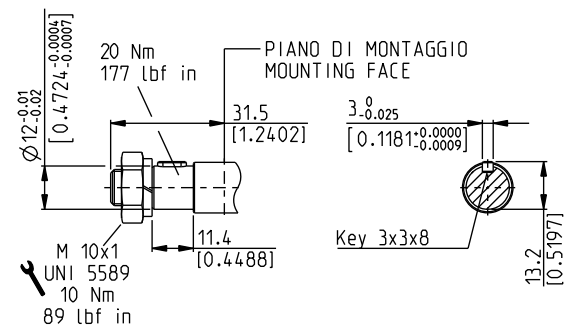

DCAT_033_043

04/10.2020

POLARIS 20

DRIVE SHAFTS

EUROPEAN TAPERED 1:8

82

Not available with size:

20•24,5

Mounting face refer to flange code **E2**

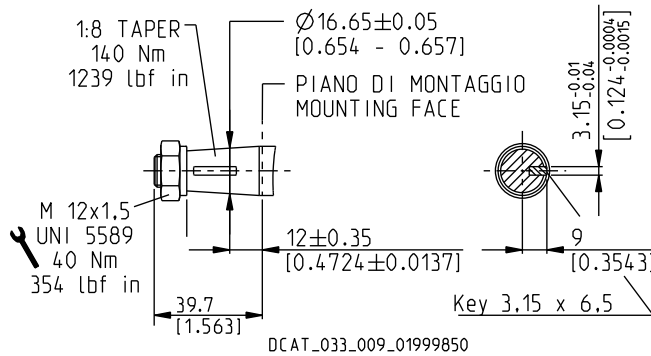

GERMAN TAPERED 1:5

55

Mounting face refer to flange code **B2**

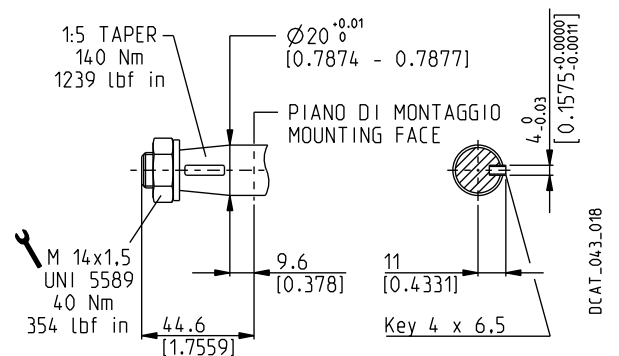

GERMAN TAPERED 1:5

54

Mounting face refer to flange code **B2**

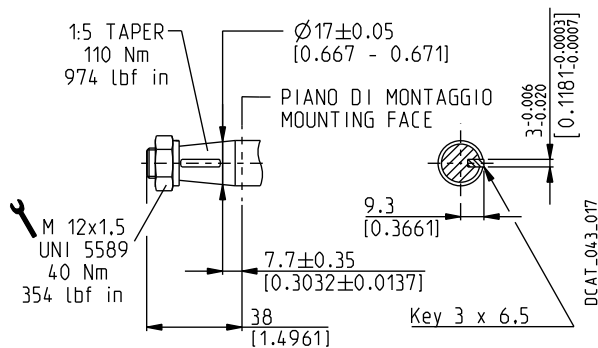

STRAIGHT

46

Not available with size:

20•7,2 20•19 20•24,5 20•27,8

Mounting face refer to flange code **E2**

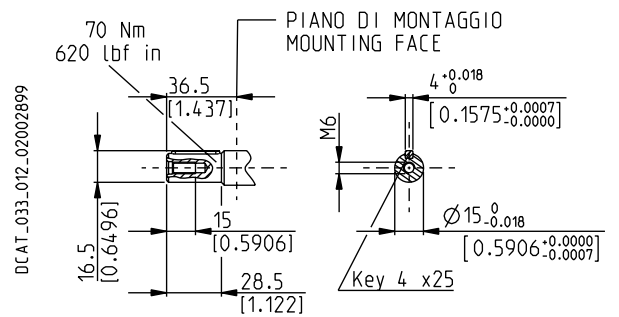

SAE "A" SPLINE

03

Mounting face refer to flange code **S1**

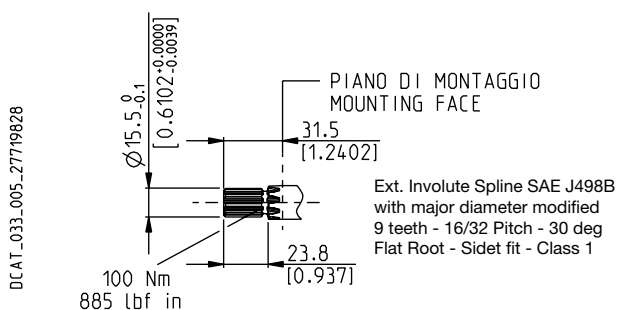

SPLINE

01

Mounting face refer to flange code **S1**

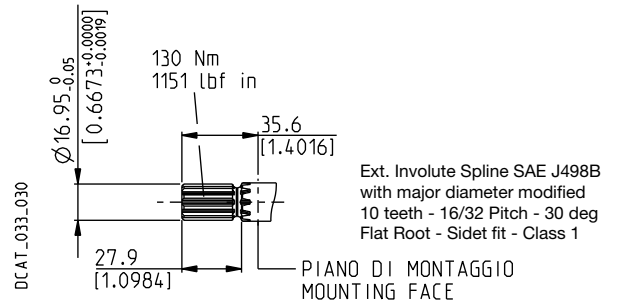

04/10.2020

POLARIS 20

DRIVE SHAFTS

SAE SPLINE

07

Mounting face refer to flange code **S1**

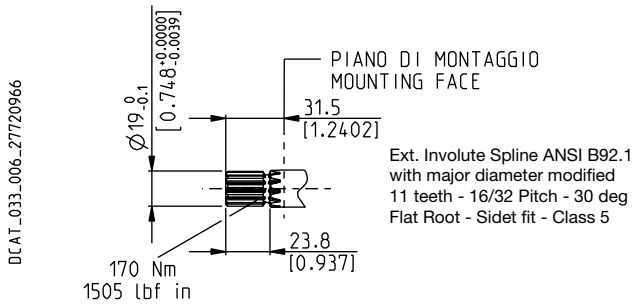

SAE "A" STRAIGHT

31

Not available with size:

20•24,5 20•27,8

Mounting face refer to flange code **S1**

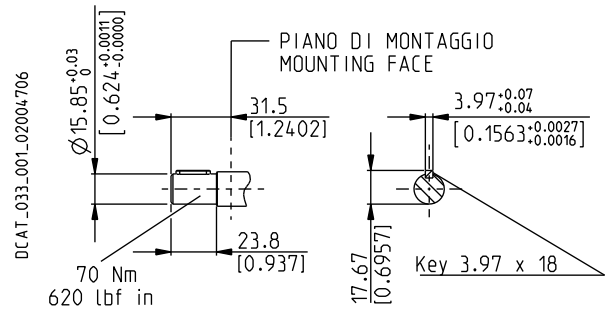

STRAIGHT

49

Not available with size:

20•19 20•24,5

Mounting face refer to flange code **S1**

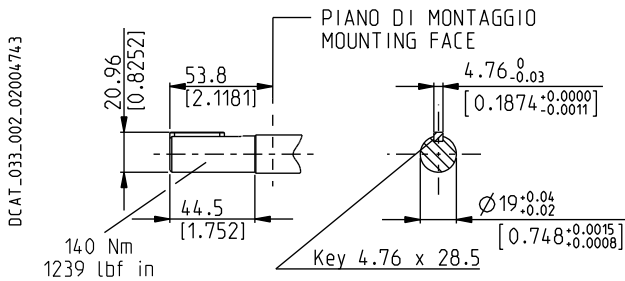

STRAIGHT

50

Mounting face refer to flange code **S1**

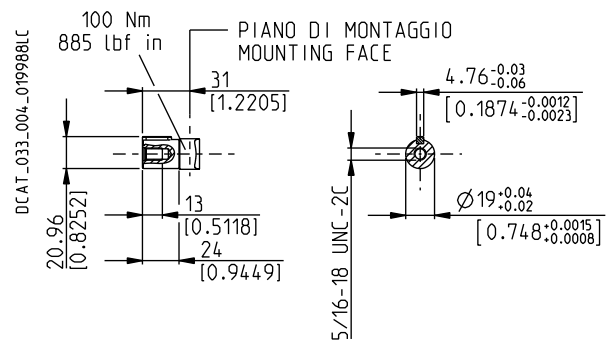

SAE "B" SPLINE

04

Mounting face refer to flange code **S5**

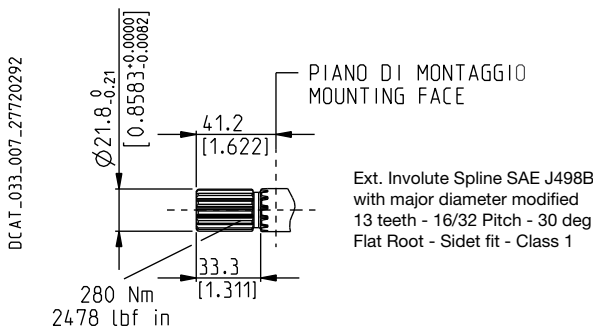

SAE "B" STRAIGHT

32

Not available with size:

20•24,5

Mounting face refer to flange code **S5**

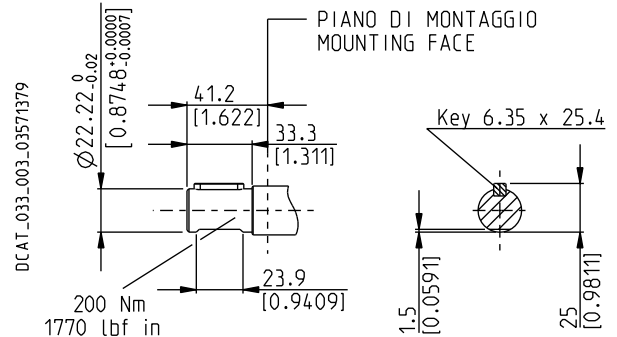

04/10.2020

POLARIS 20

DRIVE SHAFTS

DIN 5482 SPLINE

12

Mounting face refer to flange code **B2**

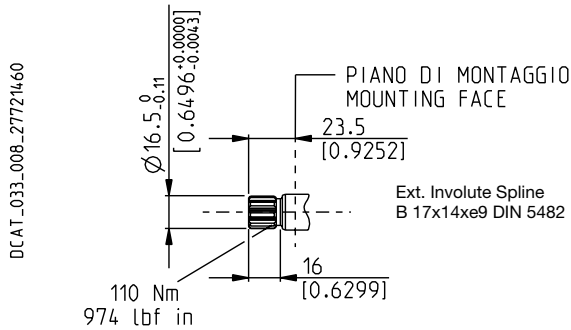

STRAIGHT

48

Only for version **5** with outboard bearing

Available in 0 version only with size:

20•20

Mounting face refer to flange code **E2**

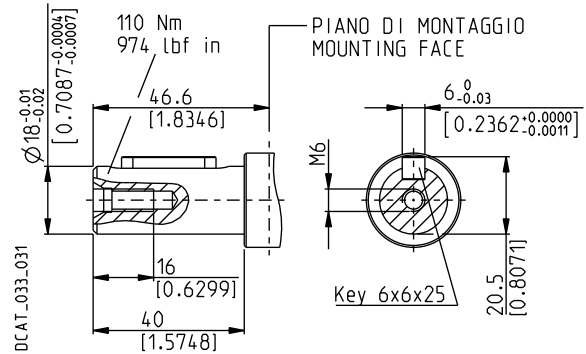

STRAIGHT

B1

Only for version **5** and **8** with outboard bearing

Mounting face refer to flange code **E2**

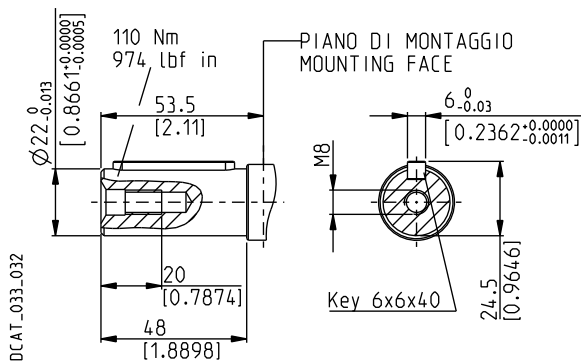

TANG

95

Not available with size:

20•19 20•24,5

Mounting face refer to flange code **B6**

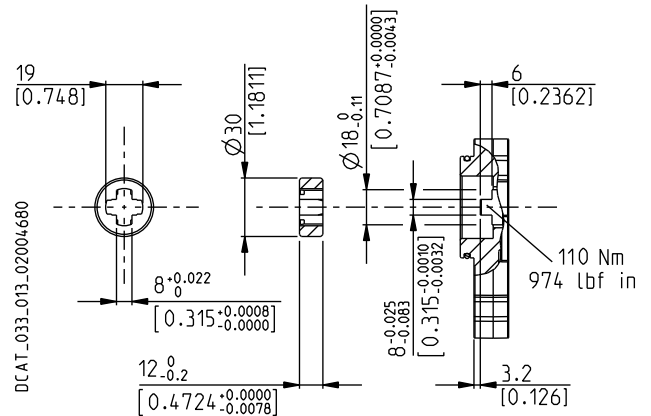

04/10.2020

POLARIS 30

DRIVE SHAFTS

EUROPEAN TAPERED 1:8

83

Not available with size:

30•82 30•90

Mounting face refer to flange code **E3**

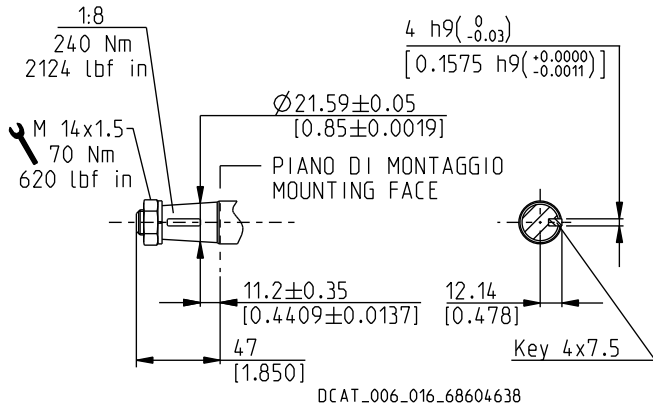

EUROPEAN TAPERED 1:8

84

Not available with size:

30•22 30•34

Mounting face refer to flange code **E4**

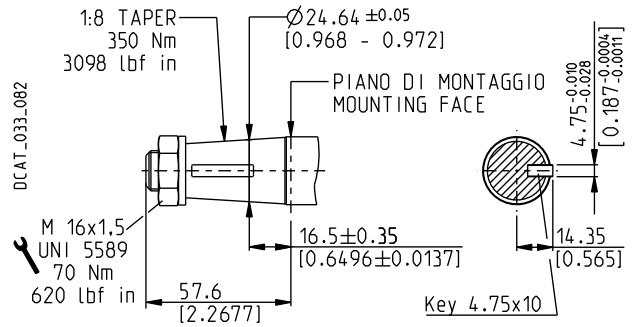

GERMAN TAPERED 1:5

56

Not available with size:

30•61 30•73 30•82 30•90

Mounting face refer to flange code **B3**

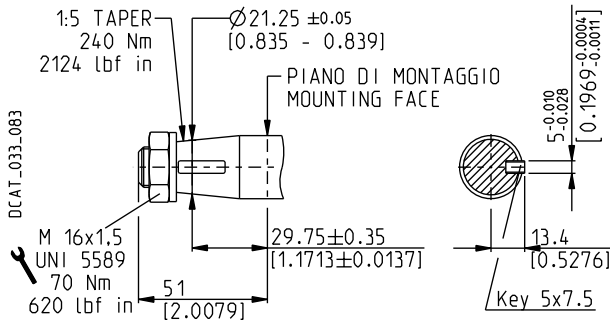

STRAIGHT

41

Not available with size:

30•82 30•90

Mounting face refer to flange code **E3**

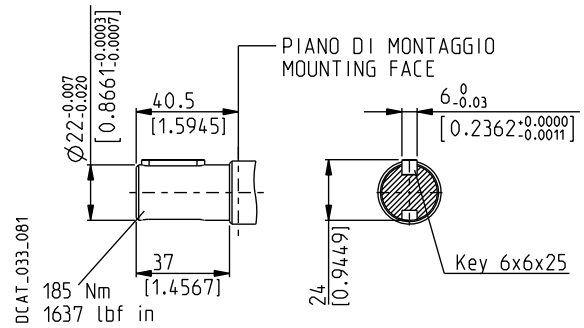

SAE "B" SPLINE

A8

Not available with size:

30•82 30•90

Mounting face refer to flange code **U3**

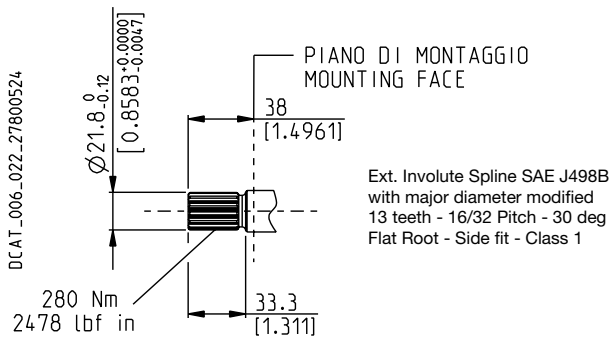

SAE "BB" SPLINE

A5

Mounting face refer to flange code **U3**

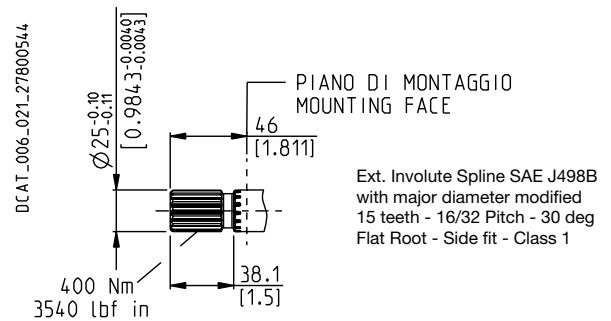

04/10.2020

POLARIS 30

DRIVE SHAFTS

SAE "B" SPLINE

04

Mounting face refer to flange code **S5**

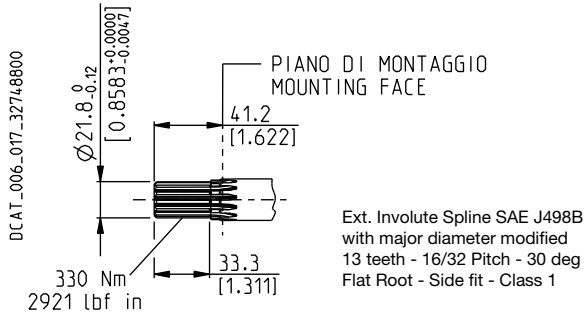

SAE "BB" SPLINE

05

Mounting face refer to flange code **S5**

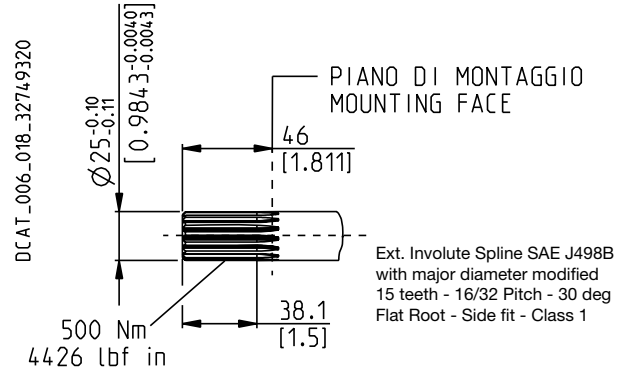

SAE "B" STRAIGHT

32

Mounting face refer to flange code **S5**

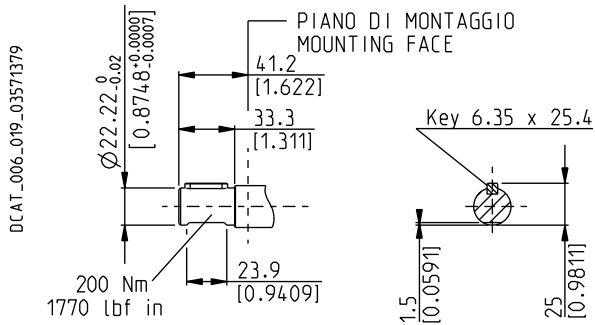

SAE "BB" STRAIGHT

33

Mounting face refer to flange code **S5**

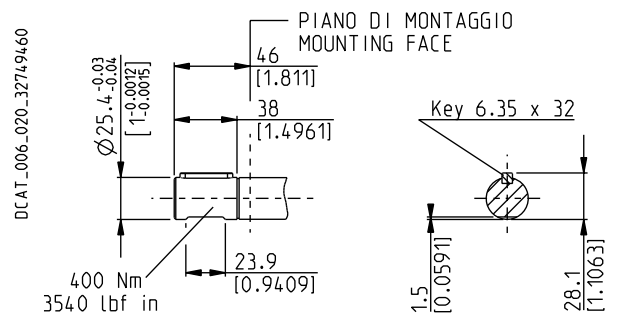

04/10.2020

POLARIS 10

MOUNTING FLANGES AND TABLE OF COMPATIBILITY

EUROPEAN

E1

Material: cast iron and aluminium

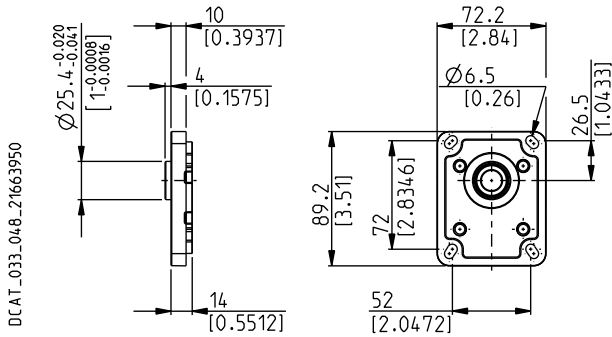

DRIVE SHAFTS
See page 52

VERSIONS	81	02	29	86
See page 48				
0	#	X	X	X

Standard combination
X Available combination

EUROPEAN

E7

Material: cast iron and aluminium

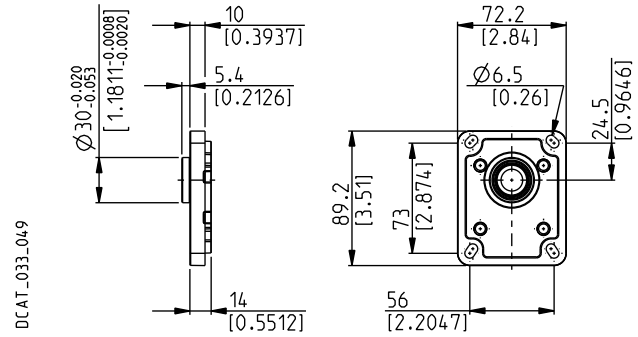

DRIVE SHAFTS
See page 52

VERSIONS	86	29	30
See page 48			
0	#	X	X

Standard combination
X Available combination

EUROPEAN

E8

Material: cast iron and aluminium

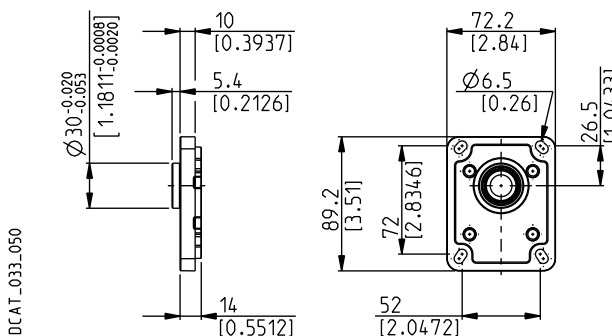

DRIVE SHAFTS
See page 52

VERSIONS	29	02
See page 48		
0	#	X

Standard combination
X Available combination

GERMAN 2 BOLTS

B1

Material: aluminium

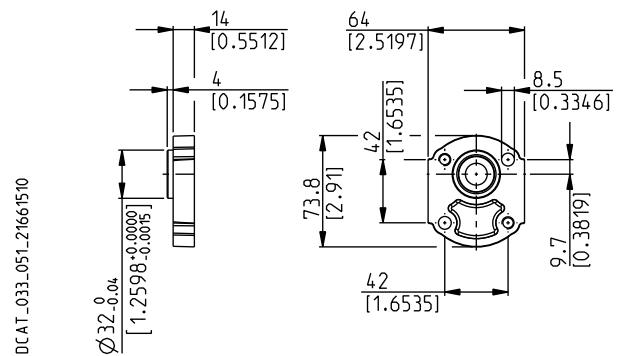

DRIVE SHAFTS
See page 52

VERSIONS	30	86
See page 48		
0	#	X

Standard combination
X Available combination

02/07.2006

POLARIS 10

MOUNTING FLANGES AND TABLE OF COMPATIBILITY

GERMAN 4 BOLTS

K2

Material: aluminium

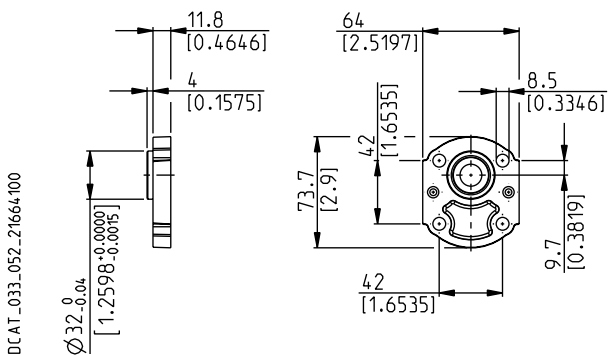

DRIVE SHAFTS

See page 52

VERSIONS	02	30
See page 48		
0	X	X

Standard combination
 X Available combination

SAE "A-A" 2 BOLTS

S0

Material: cast iron and aluminium

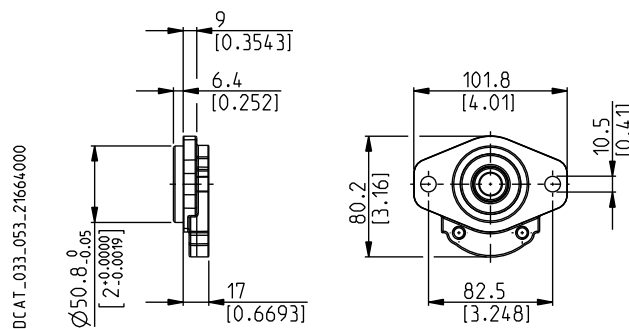

DRIVE SHAFTS

See page 52

VERSIONS	30	02	86
See page 48			
0	#	X	X

Standard combination
 X Available combination

SAE "A-A" 2-4 BOLTS

R9

Material: cast iron

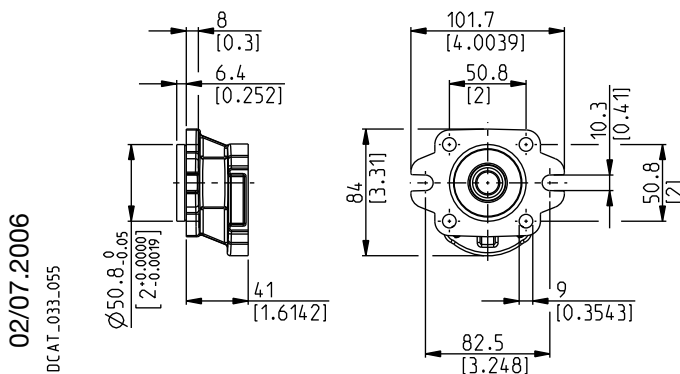

DRIVE SHAFTS

See page 52

VERSIONS	02	30	36
See page 48			
0	#	X	#

Standard combination
 X Available combination

SAE 2-4 BOLTS

R8

Material: cast iron

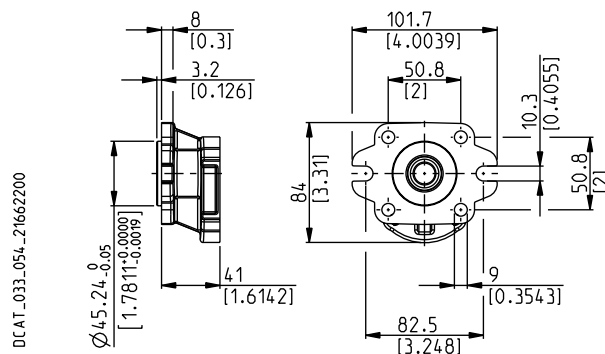

DRIVE SHAFTS

See page 52

VERSIONS	02	30	36
See page 48			
0	#	X	#

Standard combination
 X Available combination

POLARIS 10

MOUNTING FLANGES AND TABLE OF COMPATIBILITY

SAE 2 BOLTS

W9

Material: cast iron

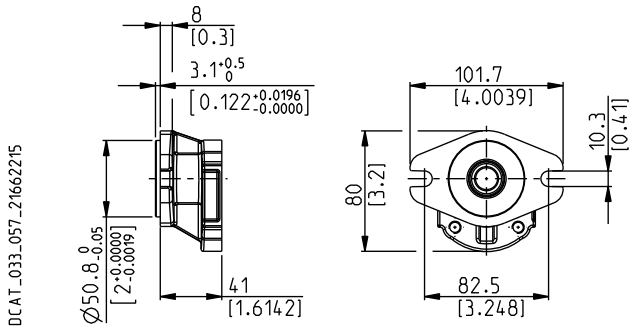

DRIVE SHAFTS

See page 52

VERSIONS

See page 48

36

0

#

Standard combination

X Available combination

02/07.2006

POLARIS 20

MOUNTING FLANGES AND TABLE OF COMPATIBILITY

EUROPEAN

E2

Material: cast iron and aluminium

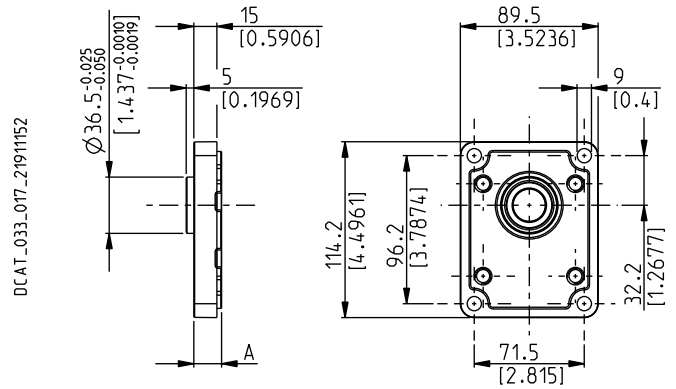

DRIVE SHAFTS

See page 53 ÷ 55

VERSIONS See page 48	A mm (in)	82	46	B1	03	04	07	12	31	48	49	50	54
0	18 (0.7087)	#	#		X	X	X	X	X	X	X	X	X
5	43,6 (1.7165)	#		X	X					#	X	X	X
7	59,4 (2.3386)	#											
8	59,4 (2.3386)			#									

Standard combination

X Available combination

GERMAN

B2

Material: cast iron and aluminium

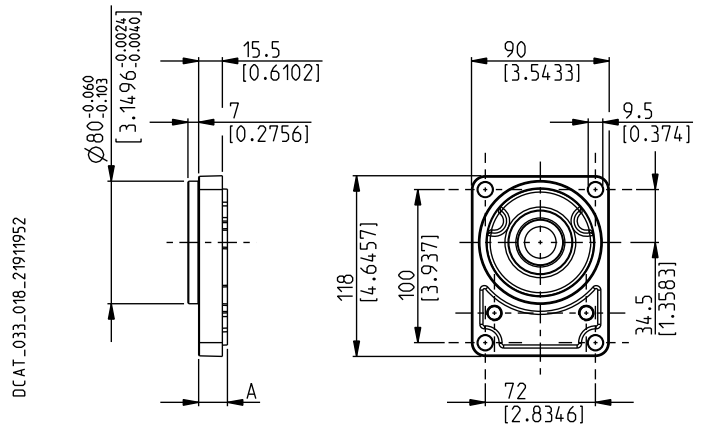

DRIVE SHAFTS

See page 53 ÷ 55

VERSIONS See page 48	A mm (in)	12	54	55	01	03	31	46	49	82
0	18,8 (0.7402)	#	#		X	X	X	X	X	X
5	44,4 (1.7480)		X	X		X			X	X
9	59,4 (1.7441)			X						

Standard combination

X Available combination

04/10.2020

POLARIS 20

MOUNTING FLANGES AND TABLE OF COMPATIBILITY

GERMAN 2 BOLTS

B4

Material: cast iron and aluminium

⊕ Through hole

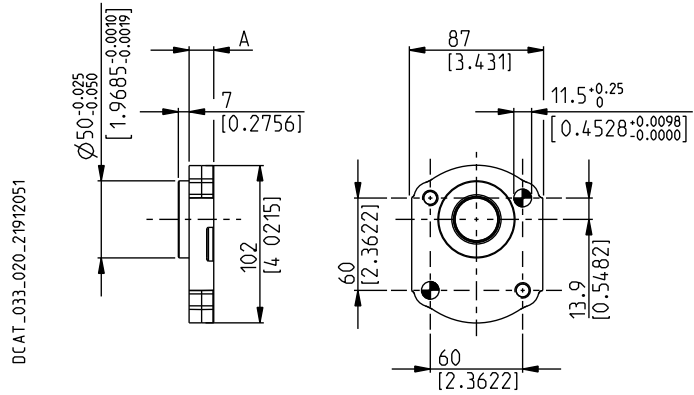

DRIVE SHAFTS

See page 53 ÷ 55

VERSIONS See page 48	A mm (in)	54	03	12	31	49	82
0	16 (0.63)	#	x	x	x	x	x
5	41,6 (1.6378)	x	x			x	x

Standard combination

x Available combination

GERMAN 2 BOLTS

B5

Material: cast iron and aluminium

⊕ Through hole

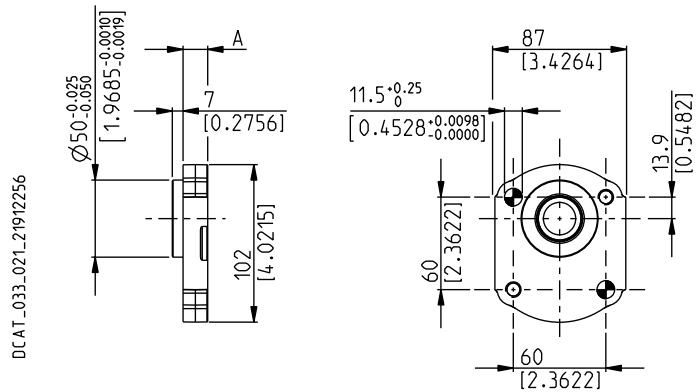

DRIVE SHAFTS

See page 53 ÷ 55

VERSIONS See page 48	A mm (in)	54	03	12	31	49	82
0	16 (0.63)	#	x	x	x	x	x
5	41,6 (1.6378)	x	x			x	x

Standard combination

x Available combination

02/07.2006

POLARIS 20

MOUNTING FLANGES AND TABLE OF COMPATIBILITY

GERMAN 2 BOLTS

U2

Material: cast iron and aluminium

⊕ Through hole

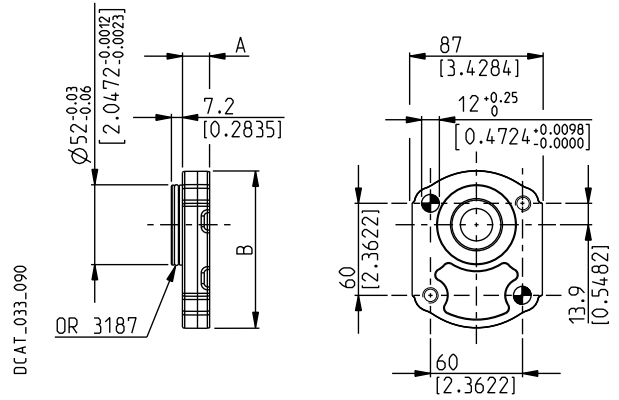

DRIVE SHAFTS

See page 54 ÷ 55

VERSIONS See page 48	A mm (in)	B mm (in)	03	54	07
0	17,7 (0.6968)	(◆) 102 (4.0157)	#		X
5	43,3 (1.747)	(●) 105 (4.1339)		X	

Standard combination (◆) Aluminium
 X Available combination (●) Cast iron

GERMAN 4 BOLTS

B6

Material: cast iron and aluminium

⊕ Through hole

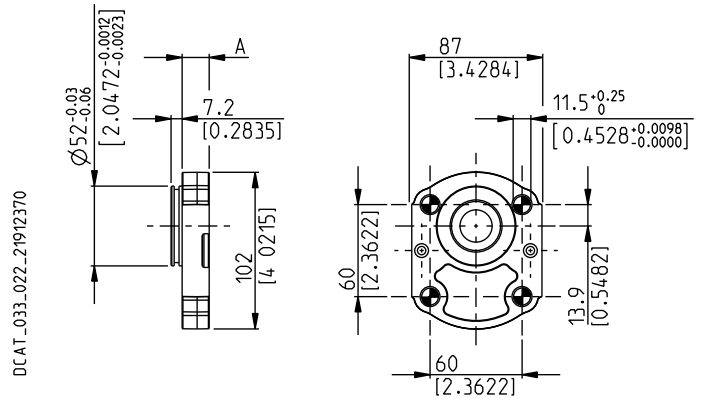

DRIVE SHAFTS

See page 54 ÷ 55

VERSIONS See page 48	A mm (in)	95	07	12
0	17,7 (0.6968)	#	X	X
5	43,3 (1.747)	X		

Standard combination
 X Available combination

04/10.2020

POLARIS 20

MOUNTING FLANGES AND TABLE OF COMPATIBILITY

SAE "A" 2 BOLTS

S1

Material: cast iron and aluminium

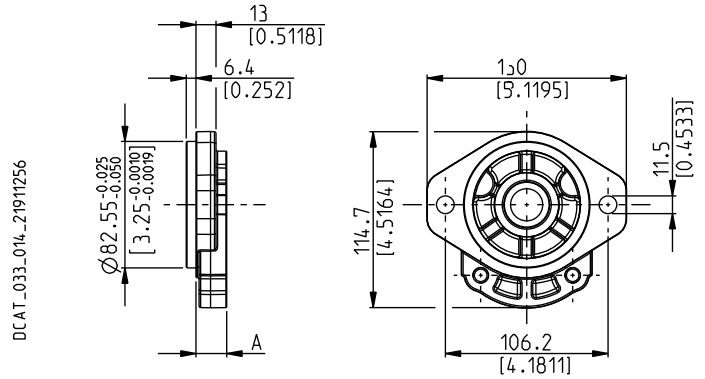

DRIVE SHAFTS

See page 53 ÷ 55

VERSIONS See page 48	A mm (in)	01	03	04	07	12	31	32	46	49	50	54	82
0	20 (0.787)	#	#	X	#	X	#	X	X	#	X	X	X
5	45,6 (1.7953)		X							X	X	X	X

Standard combination

X Available combination

SAE "A" 2 BOLTS

S2

Material: cast iron and aluminium

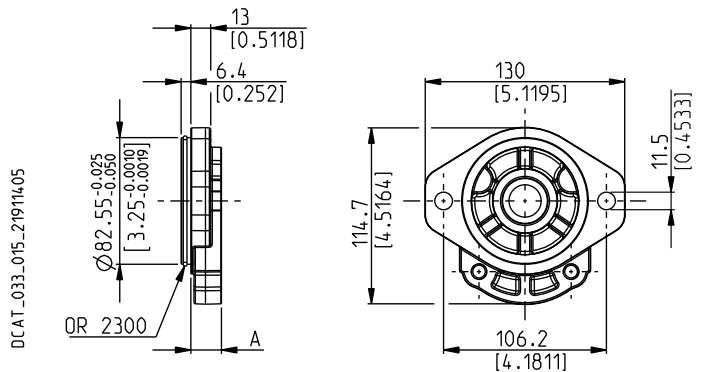

DRIVE SHAFTS

See page 53 ÷ 55

VERSIONS See page 48	A mm (in)	01	03	04	07	12	31	32	46	49	50	54	82
0	20 (0.7874)	#	#	X	#	X	#	X	X	#	X	X	X
5	45,6 (1.7953)		X							X	X	X	X

Standard combination

X Available combination

02/07.2006

POLARIS 20

MOUNTING FLANGES AND TABLE OF COMPATIBILITY

SAE "A" 2 BOLTS

S9

Material: cast iron and aluminium

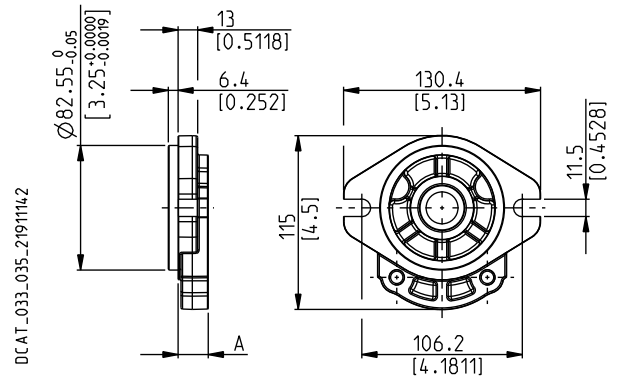

DRIVE SHAFTS

See page 53 ÷ 55

VERSIONS See page 48	A mm (in)	01	03	04	07	12	31	32	46	49	50	54	82
0	20 (0.7874)	#	#	X	#	X	#	X	X	#	X	X	X
5	45,6 (1.7953)		X							X	X	X	X

Standard combination

X Available combination

SAE "B" 2 BOLTS

S5

Material: cast iron

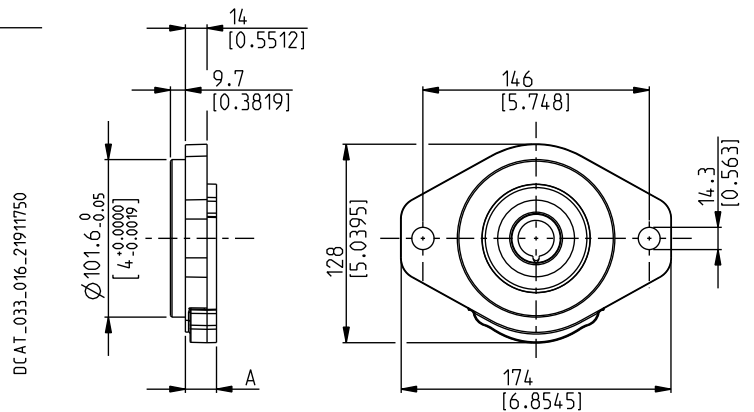

DRIVE SHAFTS

See page 54

VERSIONS See page 48	A mm (in)	04	32	49
0	20 (0.7874)	#	#	X
5	45,6 (1.7953)			X

Standard combination

X Available combination

02/07.2006

POLARIS 20

MOUNTING FLANGES AND TABLE OF COMPATIBILITY

GERMAN

W8

Material: cast iron

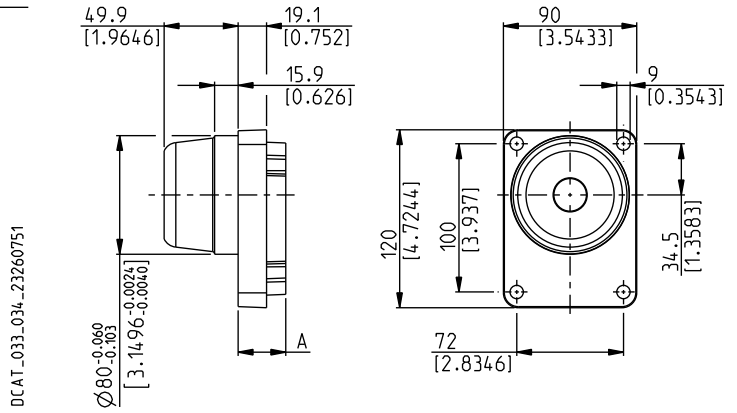

DRIVE SHAFTS

See page 53

VERSIONS See page 48	A mm (in)	55
W8	32,1 (1.2638)	#

Standard combination

X Available combination

02/07.2006

POLARIS 30

MOUNTING FLANGES AND TABLE OF COMPATIBILITY

EUROPEAN

E3

Material: cast iron

D033-199/0706

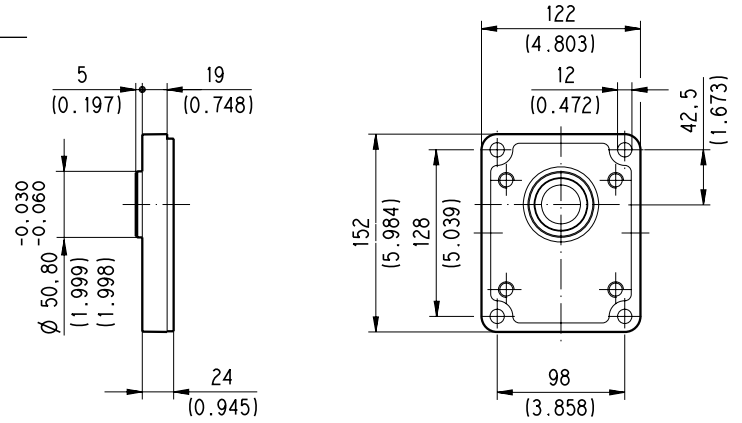

DRIVE SHAFTS

See page 56 ÷ 57

VERSIONS See page 48	83	41	04	05	32	33	A5	A8
0	#	#	X	X	X	X	X	X

Standard combination

X Available combination

EUROPEAN

E4

Material: cast iron

D033-200/0703

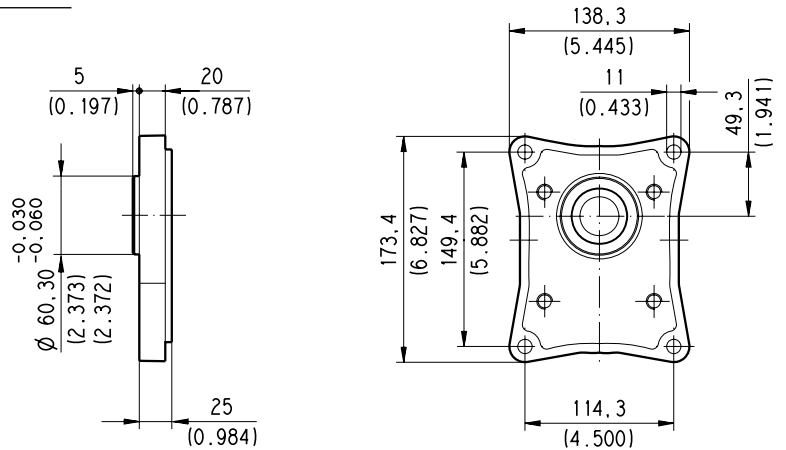

DRIVE SHAFTS

See page 56

VERSIONS See page 48	84	41	A5	A8
0	#	X	X	X

Standard combination

X Available combination

02/07.2006

POLARIS 30

MOUNTING FLANGES AND TABLE OF COMPATIBILITY

GERMAN

B3

Material: cast iron

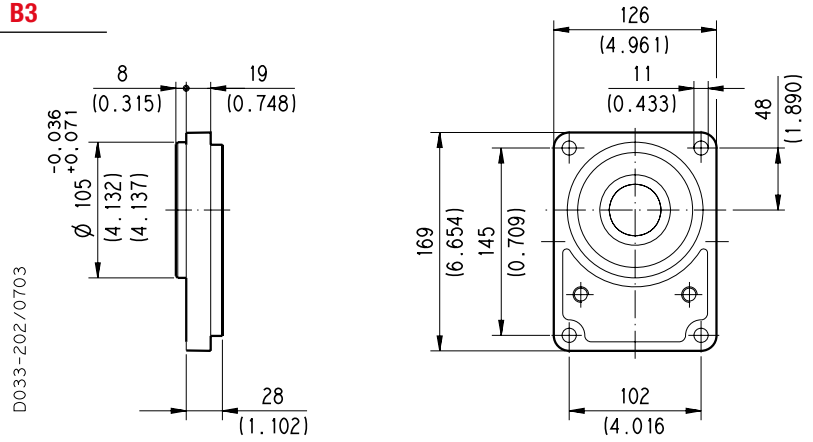

DRIVE SHAFTS
See page 56

VERSIONS See page 48	56	83	A5	A8
0	#	X	X	X

Standard combination

X Available combination

SAE "B" 2 BOLTS

S5

Material: cast iron

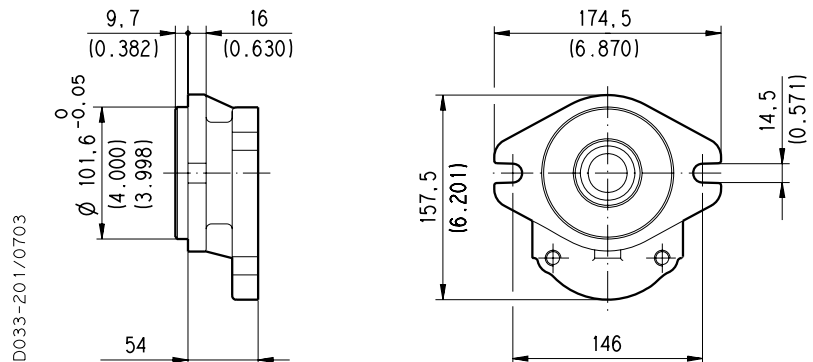

DRIVE SHAFTS
See page 57

VERSIONS See page 48	04	05	32	33
0	#	#	#	#

Standard combination

X Available combination

02/07.2006

POLARIS 30

MOUNTING FLANGES AND TABLE OF COMPATIBILITY

SAE "B" 2 BOLTS

U3

Material: cast iron

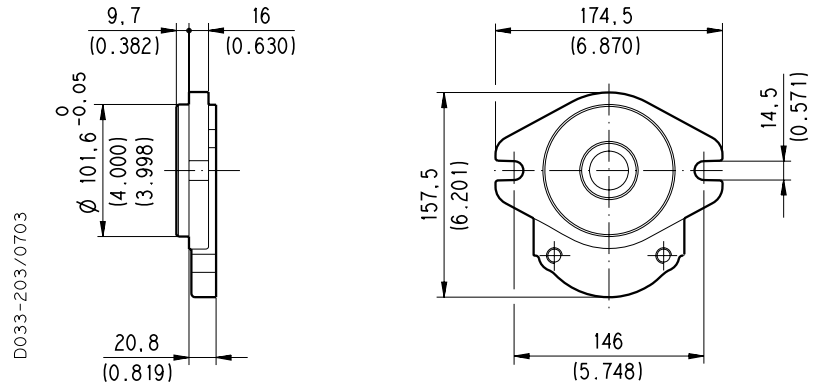

DRIVE SHAFTS
See page 56

VERSIONS See page 48	A5	A8	83
0	#	#	X

Standard combination
X Available combination

02/07.2006

PORTS POSITION AND TYPE

PORTS TYPE	SIDE PORTS												REAR PORTS			
	German		European		Split SSM		Spit SSS		Gas BSPP		SAE ODT		Gas BSPP		SAE ODT	
Pump type	IN	OUT	IN	OUT	IN	OUT	IN	OUT	IN	OUT	IN	OUT	IN	OUT	IN	OUT
Motor type	OUT	IN	OUT	IN	OUT	IN	OUT	IN	OUT	IN	OUT	IN	OUT	IN	OUT	IN
PL. 10•1	BB	BA							GC	GC	OB	OA	GC	GC	OB	OA
PL. 10•1,5	BB	BA							GC	GC	OB	OA	GC	GC	OB	OA
PL. 10•2	BB	BA							GC	GC	OB	OA	GC	GC	OB	OA
PL. 10•2,5	BB	BA							GC	GC	OB	OA	GC	GC	OB	OA
PL. 10•3,15	BB	BA							GC	GC	OB	OA	GC	GC	OB	OA
PL. 10•4	BB	BA							GC	GC	OB	OA	GC	GC	OB	OA
PL. 10•5	BB	BA							GD	GD	OB	OA	GD	GD	OB	OA
PL. 10•5,8	BB	BA							GD	GD	OB	OA	GD	GD	OB	OA
PL. 10•6,3	BB	BA							GD	GD	OB	OA	GD	GD	OB	OA
PL. 10•8	BB	BA							GD	GD	OC	OB	GD	GD	OB	OB
PL. 10•10	BB	BA							GD	GD	OC	OB	GD	GD	OB	OB
PL. 20•4	BE	BC	EA	EA	MA	MA	SA	SA	GD	GD	OC	OC	GD	GD	OC	OC
PL. 20•6,3	BE	BC	EA	EA	MA	MA	SA	SA	GD	GD	OC	OC	GD	GD	OC	OC
PL. 20•7,2	BE	BC	EA	EA	MA	MA	SA	SA	GD	GD	OC	OC	GD	GD	OC	OC
PL. 20•8	BE	BC	EA	EA	MA	MA	SA	SA	GD	GD	OC	OC	GD	GD	OC	OC
PL. 20•9	BE	BC	EA	EA	MA	MA	SA	SA	GD	GD	OC	OC	GD	GD	OC	OC
PL. 20•10,5	BE	BC	EA	EA	MA	MA	SA	SA	GD	GD	OC	OC	GD	GD	OC	OC
PL. 20•11,2	BE	BC	EA	EA	MA	MA	SA	SA	GD	GD	OC	OC	GD	GD	OC	OC
PL. 20•14	BE	BC	EB	EA	MB	MA	SB	SA	GE	GD	OD	OC	GE	GD	OD	OC
PL. 20•16	BE	BC	EB	EA	MB	MA	SB	SA	GE	GD	OD	OC	GE	GD	OD	OC
PL. 20•19	BE	BC	EB	EA	MB	MA	SB	SA	GE	GD	OD	OC	GE	GD	OD	OC
PL. 20•20	BE	BC	EB	EA	MB	MA	SB	SA	GE	GD	OD	OC	GE	GD	OD	OC
PL. 20•24,5	BE	BC	EB	EA	MC	MB	SC	SB	GE	GD	OD	OC	GE	GD	OD	OC
PL. 20•25	BE	BC	EB	EA	MC	MB	SC	SB	GE	GD	OD	OC	GE	GD	OD	OC
PL. 20•27,8	BE	BC	EB	EA	MC	MB	SC	SB	GE	GD	OD	OC	GE	GD	OD	OC
PL. 20•31,5	BE	BC	EB	EA	MC	MB	SC	SB	GE	GD	OD	OC	GE	GD	OD	OC
PL. 30•22	BM	BL	ED	EB	MB	MA	SB	SA	GF	GF	OF	OD				
PL. 30•27	BM	BL	ED	EB	MC	MB	SC	SB	GF	GF	OF	OD				
PL. 30•34	BM	BL	ED	EB	MC	MB	SC	SB	GF	GF	OF	OD				
PL. 30•38	BM	BL	ED	EB	MD	MC	SD	SC	GF	GF	OG	OF				
PL. 30•43	BM	BL	ED	EB	MD	MC	SD	SC	GF	GF	OG	OF				
PL. 30•51	BM	BL	ED	EB	MD	MC	SD	SC	GF	GF	OG	OF				
PL. 30•61	BM	BL	ED	EB	ME	MD	SE	SD	GG	GF	OH	OG				
PL. 30•73	BM	BL	EF	ED	ME	MD	SE	SD	GG	GF	OH	OG				
PL. 30•82	BM	BL	EF	ED	ME	MD	SE	SD	GH	GG	OH	OG				
PL. 30•90	BM	BL	EF	ED	MF	ME	SF	SE	GH	GG	OH	OG				

01/10.2003

EXTERNAL DRAIN PORTS

IN/OUT PORTS TYPE	SIDE PORTS						REAR PORTS	
	German	European	Split SSM	Spit SSS	Gas BSPP	SAE ODT	Gas BSPP	SAE ODT
PL. 10	GA	-	-	-	GA	03	GA	03
PL. 20	TA	GB	GB	03	GB	03	GB	03
PL. 30	GC	GC	GC	OA	GC	OA	-	-

DRAIN PORTS SIZES

 Tightening torque for low pressure side port

GAS STRAIGHT THREAD PORTS

BSPP

British standard pipe parallel (55°) conforms to UNI - ISO 228

CODE	NOMINAL SIZE	A	Ø B	Ø C	D	E	 Nm (lbf in)
			mm (in)	mm (in)	mm (in)	mm (in)	
GA	1/8"	G 1/8	16,5 (0.6496)	8,75 (0.3444)	12 (0.4724)	1 (0.0394)	5 ^{+0,25} (44 ÷ 46)
GB	1/4"	G 1/4	21,5 (0.8465)	12 (0.4724)	15 (0.5906)	1,5 (0.0591)	15 ⁺¹ (133 ÷ 142)

DCAT_006_026_21064779

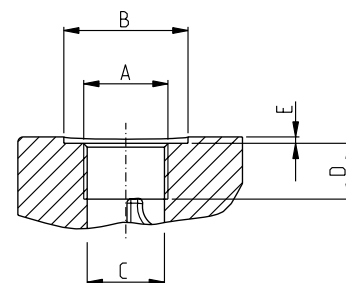

METRIC STRAIGHT THREAD PORTS ISO 6149

METRIC

Metric thread ISO 60° conforms to ISO/R 262

CODE	A	Ø B	Ø C	D	E	 Nm (lbf in)
		mm (in)	mm (in)	mm (in)	mm (in)	
TA	M 10x1	22 (0.8661)	9 (0.3543)	13 (0.5118)	0,5 (0.0197)	10 ^{+0,5} (89 ÷ 93)

DCAT_006_027_21060524

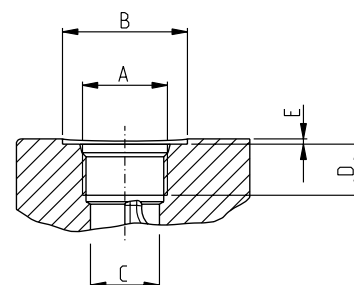

SAE STRAIGHT THREAD PORTS J514

ODT

American straight UNC-UNF 60° conforms to ANSI B 1.1

CODE	A	Ø B	Ø C	D	E	 Nm (lbf in)
		mm (in)	mm (in)	mm (in)	mm (in)	
03	7/16"-20 UNF-2B	21 (0.8267)	9,5 (0.3740)	14 (0.5512)	1 (0.0394)	12 ⁺¹ (106 ÷ 115)

Other drain ports are shown on subsequent pages.

01/10.2003

PORTS SIZE



Tightening torque for low pressure side port.





Tightening torque for high pressure side port.

For reversible rotation, please consult only the tightening torque for high pressure side port.

GERMAN FLANGED PORTS - 4 Bolts

GERMAN

Metric thread ISO 60° conforms to ISO/R 262

CODE	A	B	C		
	mm (in)	mm (in)	Thread Depth mm (in)	Nm (lbf in)	Nm (lbf in)
BA	8 (0.3150)	30 (1.1811)	M6 12 (0.4724)	8 ^{+0.5} (71 ÷ 75)	8 ^{+0.5} (71 ÷ 75)
BB	13 (0.5118)	30 (1.1811)	M6 12 (0.4724)	8 ^{+0.5} (71 ÷ 75)	8 ^{+0.5} (71 ÷ 75)
BC	15 (0.5906)	35 (1.3780)	M6 12 (0.4724)	8 ^{+0.5} (71 ÷ 75)	8 ^{+0.5} (71 ÷ 75)
BE	20 (0.7874)	40 (1.5748)	M6 12 (0.4724)	8 ^{+0.5} (71 ÷ 75)	8 ^{+0.5} (71 ÷ 75)
BL	19 (0.7480)	55 (2.1654)	M8 18 (0.7087)	15 ⁺¹ (133 ÷ 142)	20 ⁺¹ (177 ÷ 186)
BM	27 (1.0630)	55 (2.1654)	M8 18 (0.7087)	15 ⁺¹ (133 ÷ 142)	20 ⁺¹ (177 ÷ 186)

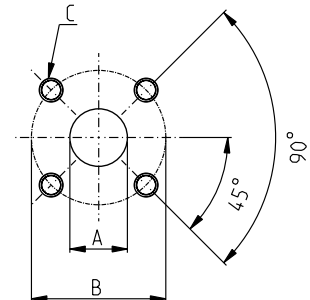

DCAT_033_028_17681888



EUROPEAN FLANGED PORTS - 4 Bolts

EUROPEAN

Metric thread ISO 60° conforms to ISO/R 262

CODE	A	B	C		
	mm (in)	mm (in)	Thread Depth mm (in)	Nm (lbf in)	Nm (lbf in)
EA	13 (0.5118)	30 (1.1811)	M 6	8 ^{+0.5} (71 ÷ 75)	8 ^{+0.5} (71 ÷ 75)
			M 8	15 ⁺¹ (133 ÷ 142)	15 ⁺¹ (133 ÷ 142)
EB	19 (0.7480)	40 (1.5748)	14 (0.5512)	(133 ÷ 142)	(133 ÷ 142)
			M 8 (◆)	15 ⁺¹ (◆)	15 ⁺¹ (◆)
			18 (0.7087)	(133 ÷ 142)	(133 ÷ 142)
ED	27 (1.0630)	51 (2.0079)	M 10 18 (0.7087)	20 ⁺¹ (177 ÷ 186)	35 ^{+2.5} (310 ÷ 332)
EF	33 (1.2992)	62 (2.4409)	M 12 18 (0.7087)	25 ⁺¹ (221 ÷ 230)	50 ^{+2.5} (443 ÷ 465)

(◆) For POLARIS 30

DCAT_006_024_21060533

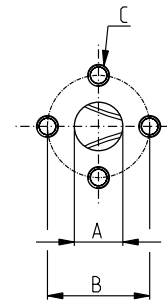

01/10.2003

PORTS SIZES



 Tightening torque for low pressure side port.

 Tightening torque for high pressure side port.

For reversible rotation, please consult only the tightening torque for high pressure side port.

SAE FLANGED PORTS J518 - Standard pressure series 3000 PSI SSM



Metric thread ISO 60° to ISO/R 262

CODE	A	B	C	D		
	mm (in)	mm (in)	mm (in)	Thread Depth mm (in)	Nm (lbf in)	Nm (lbf in)
MA	12,5 (0.4921)	38,1 (1.50)	17,5 (0.6890)	M 8	15 ⁺¹	15 ⁺¹
				14 (0.5512)	(133 ÷ 142)	(133 ÷ 142)
				M 8 (◆)	20 ⁺¹ (◆)	20 ⁺¹ (◆)
MB	19 (0.7480)	47,6 (1.8740)	22,2 (0.8740)	M 10	20 ⁺¹	25 ⁺¹
				14 (0.5512)	(177 ÷ 186)	(266 ÷ 288)
				M 10 (◆)	20 ⁺¹ (◆)	35 ^{+2,5} (◆)
MC	25,4 (1.0000)	52,4 (2.0630)	26,2 (1.0315)	M 10	20 ⁺¹	25 ⁺¹
				14 (0.5512)	(177 ÷ 186)	(266 ÷ 288)
				M 10 (◆)	20 ⁺¹ (◆)	35 ^{+2,5} (◆)
MD	30,5 (1.2008)	58,7 (2.3110)	30,2 (1.1890)	M 10	20 ⁺¹	30 ^{+2,5}
				15 (0.5906)	(177 ÷ 186)	(266 ÷ 288)
				M 10 (◆)	20 ⁺¹ (◆)	35 ^{+2,5} (◆)
ME	39,3 (1.5472)	69,8 (2.7480)	35,7 (1.4055)	M 12	30 ^{+2,5}	60 ⁺⁵
				22 (0.8661)	(266 ÷ 288)	(531 ÷ 575)
MF	51 (2.0079)	77,8 (3.0630)	42,9 (1.6890)	M 12	30 ^{+2,5}	60 ⁺⁵
				22 (0.8661)	(266 ÷ 288)	(531 ÷ 575)

(◆) For POLARIS 30

SAE FLANGED PORTS J518 - Standard pressure series 3000 PSI SSS

American straight thread UNC-UNF 60° conforms to ANSI B 1.1

CODE	A	B	C	D		
	mm (in)	mm (in)	mm (in)	Thread Depth mm (in)	Nm (lbf in)	Nm (lbf in)
SA	12,5 (0.4921)	38,1 (1.50)	17,5 (0.6890)	5/16-18 UNC-2B	15 ⁺¹	15 ⁺¹
				14 (0.5512)	(133 ÷ 142)	(133 ÷ 142)
				5/16-18 UNC-2B (◆)	20 ⁺¹ (◆)	20 ⁺¹ (◆)
SB	19 (0.7480)	47,6 (1.8740)	22,2 (0.8740)	3/8-16 UNC-2B	20 ⁺¹	20 ⁺¹
				14 (0.5512)	(177 ÷ 186)	(177 ÷ 186)
				3/8-16 UNC-2B (◆)	30 ^{+2,5} (◆)	20 ⁺¹ (◆)
SC	25,4 (1.0000)	52,4 (2.0630)	26,2 (1.0315)	3/8-16 UNC-2B	20 ⁺¹	25 ⁺¹
				14 (0.5512)	(177 ÷ 186)	(221 ÷ 230)
				3/8-16 UNC-2B (◆)	20 ⁺¹ (◆)	30 ^{+2,5} (◆)
SD	30,5 (1.2008)	58,7 (2.3110)	30,2 (1.1890)	7/16-14 UNC-2B	20 ⁺¹	45 ^{+2,5}
				22 (0.8661)	(177 ÷ 186)	(398 ÷ 420)
SE	39,3 (1.5472)	69,8 (2.7480)	35,7 (1.4055)	1/2-13 UNC-2B	30 ^{+2,5}	70 ⁺⁵
				22 (0.8661)	(266 ÷ 288)	(620 ÷ 664)
SF	51 (2.0079)	77,8 (3.0630)	42,9 (1.6890)	1/2-13 UNC-2B	30 ^{+2,5} (◆)	70 ⁺⁵
				22 (0.8661)	(266 ÷ 288)	(620 ÷ 664)

(◆) For POLARIS 30

DCAT_006_025_21064252

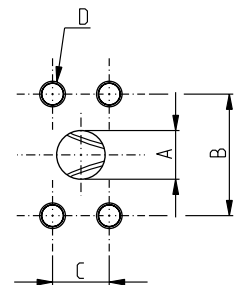

01/10.2003

DCAT_006_028_21060740

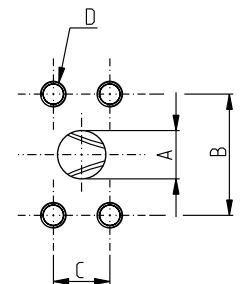

PORTS SIZE



Tightening torque for low pressure side port.



Tightening torque for high pressure side port.

For reversible rotation, please consult only the tightening torque for high pressure side port.

GAS STRAIGHT THREAD PORTS

BSPP

British standard pipe parallel (55°) conforms to UNI - ISO 228

DCAT_006-026-21064779

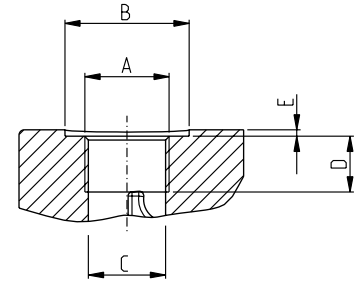

CODE	Nominal size	A	Ø B	Ø C	D	E		
			mm (in)	mm (in)	mm (in)	mm (in)	Nm (lbf in)	Nm (lbf in)
GC	3/8"	G 3/8	30 (#) (1.1811)	15 (0.5906)	10 (#) (0.3937)	2 (#) (0.0787)	15 ⁺¹ (#) (133 ÷ 142)	—
			—		14 (0.5512)	—	15 ⁺¹ (133 ÷ 142)	25 ⁺¹ (221 ÷ 230)
GD	1/2"	G 1/2	—	19 (0.7480)	14 (0.5512) 17 (◆) (0.6693)	—	20 ⁺¹ (177 ÷ 186)	50 ^{+2,5} (443 ÷ 465)
GE	3/4"	G 3/4	—	24,5 (0.9646)	18 (0.7087)	—	30 ^{+2,5} (266 ÷ 288)	90 ⁺⁵ (797 ÷ 841)
GF	1"	G 1	—	30,5 (1.2008)	18 (0.7086)	—	50 ^{+2,5} (443 ÷ 465)	130 ⁺¹⁰ (1151 ÷ 1239)
GG	1" 1/4	G 1 1/4	—	39 (1.5354)	22 (0.8661)	—	60 ⁺⁵ (531 ÷ 575)	170 ⁺¹⁰ (1505 ÷ 1593)
GH	1" 1/2	G 1 1/2	—	45 (1.7716)	24 (0.9448)	—	70 ⁺⁵ (620 ÷ 664)	210 ⁺¹⁵ (1859 ÷ 1992)

(#) = Drain port

(◆) For POLARIS 20

02/07.2006

PORTS SIZES

 Tightening torque for low pressure side port.

 Tightening torque for high pressure side port.



For reversible rotation, please consult only the tightening torque for high pressure side port.

SAE STRAIGHT THREAD PORTS J514

ODT

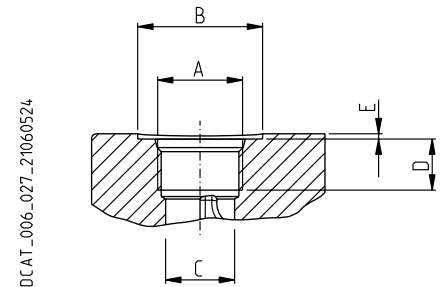
American straight thread UNC-UNF 60° conforms to ANSI B 1.1



CODE	Nominal size	A	Ø B		Ø C		D	E		
			mm (in)	mm (in)	mm (in)	mm (in)				
OA	3/8"	9/16" - 18 UNF - 2B	26 (1.0236)	13 (0.5118)	15 (0.5906)	1 (0.03934)	15 ⁺¹ (133 ÷ 142)	25 ⁺¹ (221 ÷ 230)	15 ⁺¹ (133 ÷ 142)	25 ⁺¹ (221 ÷ 230)
OB	1/2"	3/4" - 16 UNF - 2B	32 (1.2598)	17,5 (0.690)	15 (0.5906)	—	20 ⁺¹ (177 ÷ 186)	45 ^{+2,5} (398 ÷ 420)	20 ⁺¹ (177 ÷ 186)	45 ^{+2,5} (398 ÷ 420)
OC	5/8"	7/8" - 14 UNF - 2B	35 (1.3780)	20,5 (0.8071)	15 (◆) (0.5906)	0,5 (0.0197)	30 ^{+2,5} (266 ÷ 288)	70 ⁺⁵ (620 ÷ 664)	30 ^{+2,5} (266 ÷ 288)	70 ⁺⁵ (620 ÷ 664)
					17 (0.6693)					
OD	3/4"	1 1/16" - 12 UNF - 2B	42 (1.6535)	24,8 (0.9764)	20 (0.7874)	0,5 (0.0197)	40 ^{+2,5} (354 ÷ 376)	120 ⁺¹⁰ (1062 ÷ 1151)	40 ^{+2,5} (354 ÷ 376)	120 ⁺¹⁰ (1062 ÷ 1151)
OF	1"	1 5/16" - 12 UNF - 2B	49 (1.9291)	30,5 (1.2008)	20 (0.7874)	0,5 (0.0197)	60 ⁺⁵ (531 ÷ 575)	170 ⁺¹⁰ (1505 ÷ 1593)	60 ⁺⁵ (531 ÷ 575)	170 ⁺¹⁰ (1505 ÷ 1593)
OG	1" 1/4	1 5/8" - 12 UNF - 2B	58 (2.2835)	39,1 (1.5394)	20 (0.7874)	0,5 (0.0197)	70 ⁺⁵ (620 ÷ 664)	200 ⁺¹⁵ (1770 ÷ 1858)	70 ⁺⁵ (620 ÷ 664)	200 ⁺¹⁵ (1770 ÷ 1858)
OH	1" 1/2	1 7/8" - 12 UNF - 2B	65 (2.5591)	45 (1.7717)	20 (0.7874)	0,5 (0.0197)	100 ⁺⁵ (885 ÷ 929)	270 ⁺¹⁵ (2389 ÷ 2522)	100 ⁺⁵ (885 ÷ 929)	270 ⁺¹⁵ (2389 ÷ 2522)

(#) = Drain port

(◆) For POLARIS 10

01/10.2003

VALVE OPTIONS

PRIORITY VALVE

P1

Costant delivery and internal recirculation of excess flow.

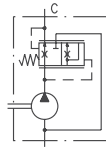

P2

Costant delivery at controlled pressure. Internal recirculation of excess flow and drain valve.

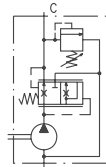

P3

Costant delivery at controlled pressure. Excess flow and drain valve must be connected to tank.

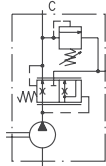

P4

Costant delivery and excess flow can both be used under load.

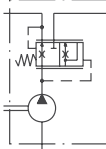

P5T

Costant delivery at controlled pressure with drain valve connected to tank. Excess flow can be used under load.

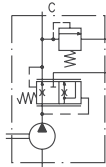

ELECTRIC VALVE

○

UNL...

By-pass valve with anti-cavitation valve.

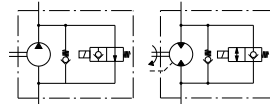

○

PRV...

Proportional relief valve.

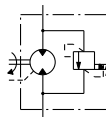

MAX PRESSURE RELIEF VALVE

VPEF...

Fixed setting with external drain.

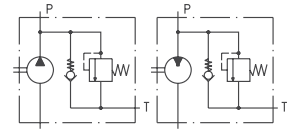

VPIF...

Fixed setting with internal drain.

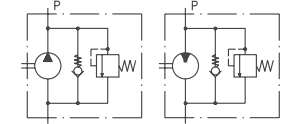

VPER...

Adjustable setting with external drain.

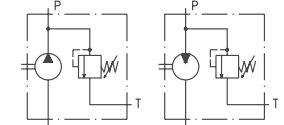

VPIR...

Adjustable setting with internal drain.

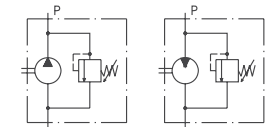

LOAD SENSING VALVE

...

Static.

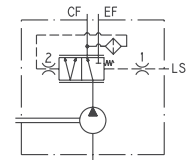

...

Dynamic.

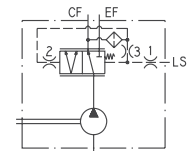

...

Dynamic with relief valve fitted on the main line.

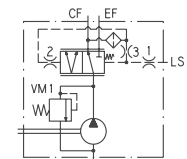

...

Dynamic with relief valve fitted on controlled line.

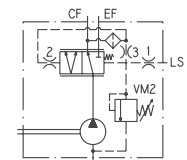

CHECK VALVE

V8

Anti-cavitation valve.

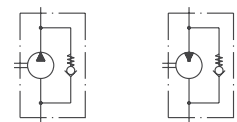

Replaces: 04/10.2020

05/04.2023

Please refer to our built-in valves and fan drive technical catalogues for more information.

NOTES

04/10.2020

HOW TO ORDER POLARIS 10 SINGLE UNITS

1	2	3	4	5	6	7	8	9	10	11	12	13							
PLP 10-1	L	0	-	81	E1	-	L	BB/BA	-	N	-	EL	-	C	-	L	GA	-	FS

1	Type	Pump type	Motor type
1,07 cm ³ /rev (0.07 in ³ /rev)		PLP 10-1	PLM 10-1
1,60 cm ³ /rev (0.10 in ³ /rev)		PLP 10-1,5	PLM 10-1,5
2,13 cm ³ /rev (0.13 in ³ /rev)		PLP 10-2	PLM 10-2
2,67 cm ³ /rev (0.16 in ³ /rev)		PLP 10-2,5	PLM 10-2,5
3,34 cm ³ /rev (0.20 in ³ /rev)		PLP 10-3,15	PLM 10-3,15
4,27 cm ³ /rev (0.26 in ³ /rev)		PLP 10-4	PLM 10-4
5,34 cm ³ /rev (0.33 in ³ /rev)		PLP 10-5	PLM 10-5
6,20 cm ³ /rev (0.38 in ³ /rev)		PLP 10-5,8	PLM 10-5,8
6,67 cm ³ /rev (0.41 in ³ /rev)		PLP 10-6,3	PLM 10-6,3
8,51 cm ³ /rev (0.52 in ³ /rev)		PLP 10-8	PLM 10-8
10,67 cm ³ /rev (0.65 in ³ /rev)		PLP 10-10	PLP 10-10

2	Rotation	Code
Left		S
Right		D
Reversible rear external drain		R
Reversible side external drain		L
Reversible internal drain		B

3	Versions - Outboard bearing options	Code
Without outboard bearing		0

4	Drive shaft	Code
European tapered 1:8		81
European tapered 1:8		86
SAE "AA" spline (9 teeth)		02
SAE "AA" straight		30
SAE straight		36
Straight		29

5	Mounting flange	Code
European		E1
European		E7
European		E8
German 2 bolt		B1
German 4 bolt		K2
SAE "AA" 2 bolt		S0
SAE "AA" 2-4 bolt		R9
SAE 2-4 bolt		R8
SAE 2 bolt		W9

Code	Ports position	6
L	Side	
P	Rear	

Code	Ports IN/OUT	7
GERMAN FLANGED PORTS		
Side	Rear	Type
BB/BA	PLP 10	1-1,5-2-2,5-3,15
BA/BB	PLM 10	4-5-5,8-6,3-8-10

GAS STRAIGHT THREAD PORTS (BSPP)			
Side	Rear	Type	
GC/GC	GC/GC	PLP 10	1-1,5-2-2,5-3,15-4
		PLM 10	
GD/GD	GD/GD	PLP 10	5-5,8-6,3-8-10
		PLM 10	

SAE STRAIGHT THREAD PORTS (ODT)			
Side	Rear	Type	
OB/OA	OB/OA	PLP 10	1-1,5-2-2,5-3,15-4
OA/OB	OA/OB	PLM 10	5-5,8-6,3
OC/OB	OB/OB	PLP 10	8-10
OB/OC	OB/OB	PLM 10	

Code	Seals (a)	8
N	Buna (standard)	
V	Viton	

Code	Cover options (b)	9
	Cast iron mounting flange and rear cover (standard - no code)	
E	Aluminium mounting flange and cast iron rear cover	
L	Cast iron mounting flange and aluminium rear cover	
EL	Aluminium mounting flange and rear cover	

Code	Shaft seal options	10
D	Standard seal with wiper seal	
C1	High back pressure seal	

04/10.2020

HOW TO ORDER POLARIS 10 SINGLE UNITS

11	Drain port position - Rev. Rotation L	Code
	Side drain with side port position	L
	Side drain with bottom port position	*

12	Drain port	Code
IN/OUT GERMAN FLANGED PORTS		
	Type	Side Rear
	1-1,5-2-2,5-3,15 PLP 10	GA
	4-5-5,8-6,3-8-10 PLM 10	
IN/OUT GAS STRAIGHT THREAD PORTS (BSPP)		
	Type	Side Rear
	1-1,5-2-2,5-3,15 PLP 10	GA GA
	4-5-5,8-6,3-8-10 PLM 10	
IN/OUT SAE STRAIGHT THREAD PORTS (ODT)		
	Type	Side Rear
	1-1,5-2-2,5-3,15 PLP 10	03 03
	4-5-5,8-6,3-8-10 PLM 10	

13	Shaft arrangement	Code
	Female spline	FS

- (a) Choose the seals according to the temperature shown on page 5
- (b) Mounting flange material on page 58 ÷ 60
Rear cover material on page 34

02/07.2006

HOW TO ORDER POLARIS 20 SINGLE UNITS

1	2	3	4	5	6	7	8	9	10	11	12	13							
PLP 20-4	L	0	-	82	E2	-	L	EA/EA	-	N	-	EL	-	C	-	*	GB	-	FS

1	Type	Pump type	Motor type
4,95 cm ³ /rev (0.30 in ³ /rev)		PLP 20-4	PLM 20-4
6,61 cm ³ /rev (0.40 in ³ /rev)		PLP 20-6,3	PLM 20-6,3
7,29 cm ³ /rev (0.44 in ³ /rev)		PLP 20-7,2	PLM 20-7,2
8,26 cm ³ /rev 0.50 in ³ /rev)		PLP 20-8	PLM 20-8
9,17 cm ³ /rev 0.56 in ³ /rev)		PLP 20-9	PLM 20-9
10,9 cm ³ /rev (0.66 in ³ /rev)		PLP 20-10,5	PLM 20-10,5
11,23 cm ³ /rev (0.69 in ³ /rev)		PLP 20-11,2	PLM 20-11,2
14,53 cm ³ /rev (0.89 in ³ /rev)		PLP 20-14	PLM 20-14
16,85 cm ³ /rev (1.03 in ³ /rev)		PLP 20-16	PLM 20-16
19,09 cm ³ /rev (1.16 in ³ /rev)		PLP 20-19	PLM 20-19
21,14 cm ³ /rev (1.29 in ³ /rev)		PLP 20-20	PLM 20-20
24,84 cm ³ /rev 1.52 in ³ /rev)		PLP 20-24,5	PLM 20-24,5
26,42 cm ³ /rev (1.61 in ³ /rev)		PLP 20-25	PLM 20-25
28,21 cm ³ /rev (1.72 in ³ /rev)		PLP 20-27,8	PLM 20-27,8
33,03 cm ³ /rev (2.01 in ³ /rev)		PLP 20-31,5	PLM 20-31,5

2	Rotation	Code
Left		S
Right		D
Reversible rear external drain		R
Reversible side external drain		L
Reversible internal drain		B

3	Versions - Outboard bearing options	Code
Without outboard bearing		0
With outboard bearing		W8
With outboard bearing		5
With outboard bearing		6
With outboard bearing		7
With outboard bearing		9

4	Drive shaft	Code
European tapered 1:8		82
German tapered 1:5		54
German tapered 1:5		55
Straight		46
SAE "A" spline (9 teeth)		03
SAE spline (10 teeth)		01
SAE "A" spline (11 teeth)		07
SAE "A" straight		31

Code	Drive shaft	4
49	Straight	
50	Straight	
04	SAE "B" spline	
32	SAE "B" straight	
12	DIN 54 82	
48	Straight (only for version 6)	
B1	Straight (for version 5 and 8)	
95	Tang	

Code	Mounting flange	5
E2	European	
B2	German	
B4	German 2 bolt	
B5	German 2 bolt	
B6	German 4 bolt	
U2	German 2 bolt	
S1	SAE "A" 2 bolt	
S2	SAE "A" 2 bolt	
S9	SAE "A" 2 bolt	
S5	SAE "B" 2 bolt	
W8	German	

Code	Ports position	6
L	Side	
P	Rear	

Code	Ports IN/OUT	7
GERMAN FLANGED PORTS		
Side	Rear	Type
BE/BC	PLP 20	4-6,3-7,2-8-9-10,5-11,2-14-16-19-20-24,5-25-27,8-31,5
BC/BE	PLM 20	27,8-31,5
EUROPEAN FLANGED PORTS		
Side	Rear	Type
EA/EA	PLP 20	4-6,3-7,2-8-9-10,5-11,2
	PLM 20	
EB/EA	PLP 20	14-16-19-20-24,5-25-27,8-31,5
EA/EB	PLM 20	27,8-31,5

04/10.2020

HOW TO ORDER POLARIS 20 SINGLE UNITS

7	Ports IN/OUT		Code
SAE FLANGED PORTS (SSM)			
Type	Side	Rear	
4-6,3-7,2-8-9-10,5-11,2	PLP 20	MA/MA	
	PLM 20		
14-16-19-20	PLP 20	MB/MA	
	PLM 20	MA/MB	
24,5-25-27,8-31,5	PLP 20	MC/MB	
	PLM 20	MB/MC	
SAE FLANGED PORTS (SSS)			
Type	Side	Rear	
4-6,3-7,2-8-9-10,5-11,2	PLP 20	SA/SA	
	PLM 20		
14-16-19-20	PLP 20	SB/SA	
	PLM 20	SA/SB	
24,5-25-27,8-31,5	PLP 20	SC/SB	
	PLM 20	SB/SC	
GAS STRAIGHT THREAD PORTS (BSPP)			
Type	Side	Rear	
4-6,3-7,2-8-9-10,5-11,2	PLP 20	GD/GD	GD/GD
	PLM 20		
14-16-19-20-24,5-25-27,8-31,5	PLP 20	GE/GD	GE/GD
	PLM 20	GD/GE	GD/GE
SAE STRAIGHT THREAD PORTS (ODT)			
Type	Side	Rear	
4-6,3-7,2-8-9-10,5-11,2	PLP 20	OC/OC	OC/OC
	PLM 20		
14-16-19-20-24,5-25-27,8-31,5	PLP 20	OD/OC	OD/OC
	PLM 20	OC/OD	OC/OD

8	Seals (a)	Code
	Buna (standard)	N
	Viton	V
	Hydrogenated buna HNBR seals with Viton-FKM shaft seals	T-PV

9	Cover options (b)	Code
	Cast iron mounting flange and rear cover (standard - no code)	
	Aluminium mounting flange and cast iron rear cover	E
	Cast iron mounting flange and aluminium rear cover	L
	Aluminium mounting flange and rear cover	EL

10	Shaft seal options	Code
	Standard seal with wiper seal	D
	High back pressure seal	C1

Code	Drain port position - Rev. rotation L	11
L	Side drain with side port position	
*	Side drain with bottom port position	

Code	Drain port		12
IN/OUT GERMAN FLANGED PORTS			
Side	Rear	Type	
TA	PLP 20	4-6,3-7,2-8-9-10,5-11,2-	
	PLM 20	24,5-25-27,8-31,5	

IN/OUT EUROPEAN FLANGED PORTS			
Side	Rear	Type	
GB	PLP 20	4-6,3-7,2-8-9-10,5-11,2-	
	PLM 20	24,5-25-27,8-31,5	

IN/OUT SAE FLANGED PORTS (SSM)			
Side	Rear	Type	
GB	PLP 20	4-6,3-7,2-8-9-10,5-11,2-	
	PLM20	24,5-25-27,8-31,5	

IN/OUT SAE FLANGED PORTS (SSS)			
Side	Rear	Type	
03	PLP 20	4-6,3-7,2-8-9-10,5-11,2-	
	PLM 20	24,5-25-27,8-31,5	

IN/OUT GAS STRAIGHT THREAD PORTS (BSPP)			
Side	Rear	Type	
GB	GB	PLP 20	4-6,3-7,2-8-9-10,5-11,2-
		PLM 20	24,5-25-27,8-31,5

IN/OUT SAE STRAIGHT THREAD PORTS (ODT)			
Side	Rear	Type	
03	03	PLP 20	4-6,3-7,2-8-9-10,5-11,2-
		PLM 20	24,5-25-27,8-31,5

Code	Shaft arrangement	13
FS	Female spline	

- (a) Choose the seals according to the temperature shown on page 4.
- (b) Mounting flange material on page 61 ÷ 66
Rear cover material on page 34 ÷ 35

04/10.2020

HOW TO ORDER POLARIS 30 SINGLE UNITS

1	2	3	4	5	6	7	8	9	10					
PLP 30-22	R	0	-	83	E3	-	L	ED/EB	-	N	-	C	-	FS

1	Type	Pump type	Motor type
21,99 cm ³ /rev (1.34 in ³ /rev)		PLP 30-22	PLM 30-22
26,70 cm ³ /rev (1.63 in ³ /rev)		PLP 30-27	PLM 30-27
34,55 cm ³ /rev (2.11 in ³ /rev)		PLP 30-34	PLM 30-34
39,27 cm ³ /rev (2.40 in ³ /rev)		PLP 30-38	PLM 30-38
43,98 cm ³ /rev (2.68 in ³ /rev)		PLP 30-43	PLM 30-43
51,83 cm ³ /rev (3.16 in ³ /rev)		PLP 30-51	PLM 30-51
61,26 cm ³ /rev (3.74 in ³ /rev)		PLP 30-61	PLM 30-61
73,82 cm ³ /rev (4.50 in ³ /rev)		PLP 30-73	PLM 30-73
81,68 cm ³ /rev (4.98 in ³ /rev)		PLP 30-82	PLM 30-82
91,10 cm ³ /rev (5.56 in ³ /rev)		PLP 30-90	PLM 30-90

2	Rotation	Code
Left		S
Right		D
Reversible rear external drain		R

3	Versions - Outboard bearing options	Code
Without outboard bearing		0

4	Drive shaft	Code
European tapered 1:8		83
European tapered 1:8		84
German tapered 1:5		56
Straight		41
SAE "B" spline		A8
SAE "BB" spline		A5
SAE "B" spline		04
SAE "BB" spline		05
SAE "B" straight		32
SAE "BB" straight		33

5	Mounting flange	Code
European		E3
European		E4
German		B3
SAE "B" 2 bolt		S5
SAE "B" 2 bolt		U3

6	Ports position	Code
Side		L

Code	Ports IN/OUT	7
GERMAN FLANGED PORTS		
Side		Type
BM/BL	PLP 30	22-27-34-38-43
BL/BM	PLM 30	46-51-61-73-82-90
EUROPEAN FLANGED PORTS		
Side		Type
ED/EB	PLP 30	22-27-34-38-43
EB/ED	PLM 30	46-51-61
EF/ED	PLP 30	73-82-90
ED/EF	PLM 30	
SAE FLANGED PORTS (SSM)		
Side		Type
MB/MA	PLP 30	22
MA/MB	PLM 30	
MC/MB	PLP 30	27-34
MB/MC	PLM 30	
MD/MC	PLP 30	38-43-46-51
MC/MD	PLM 30	
ME/MD	PLP 30	61-73-82
MD/ME	PLM 30	
MF/ME	PLP 30	90
ME/MF	PLM 30	
SAE FLANGED PORTS (SSS)		
Side		Type
SB/SA	PLP 30	22
SA/SB	PLM 30	
SC/SB	PLP 30	27-34
SB/SC	PLM 30	
SD/SC	PLP 30	38-43-46-51
SC/SB	PLM 30	
SE/SD	PLP 30	61-73-82
SD/SE	PLM 30	
SF/SE	PLP 30	90
SE/SF	PLM 30	
GAS STRAIGHT THREAD PORTS (BSPP)		
Side		Type
GF/GF	PLP 30	22-27-34-38-43-46-51
GF/GF	PLM 30	
GG/GF	PLP 30	61-73
GF/GG	PLM 30	
GH/GG	PLP 30	82-90
GG/GH	PLM 30	

02/07.2006

HOW TO ORDER POLARIS 30 SINGLE UNITS

7	Ports IN/OUT	Code
SAE STRAIGHT THREAD PORTS (ODT)		
	Type	Rear
	22-27-34	PLP 30 OF/OD PLM 30 OD/OF
	38-43-46-51	PLP 30 OG/OF PLM 30 OF/OG
	61-73-82-90	PLP 30 OH/OG PLM 30 OG/OH

8	Seals (a)	Code
	Buna (standard)	N
	Viton	V

9	Shaft seal options	Code
	Standard seal with wiper seal	D
	High back pressure seal	C1

10	Shaft arrangement	Code
	Female spline	FS

- (a) Choose the seals according to the temperature shown on page 5.

04/10.2020

HOW TO ORDER POLARIS 10 MULTIPLE PUMPS

1	2	3	4	5	6	7	8	9	10	11	12								
PLP 10-1	-	81	E1	-	L	BA/BA	/												
Front section																			
10-1	-				L	BA/BA	/												
Intermediate section																			
10-1	-				L	**/BA	-	V7	-	S	0	-	N	-	EL	-	C	/	FS
Rear section																			

1	Type	Pump type
	0,07 in ³ /rev (1,07 cm ³ /rev)	PLP 10-1
	1,60 cm ³ /rev (0.10 in ³ /rev)	PLP 10-1,5
	2,13 cm ³ /rev (0.13 in ³ /rev)	PLP 10-2
	2,67 cm ³ /rev 0.16 in ³ /rev)	PLP 10-2,5
	3,34 cm ³ /rev (0.20 in ³ /rev)	PLP 10-3,15
	4,27 cm ³ /rev 0.26 in ³ /rev)	PLP 10-4
	5,34 cm ³ /rev (0.33 in ³ /rev)	PLP 10-5
	6,20 cm ³ /rev (0.38 in ³ /rev)	PLP 10-5,8
	6,67 cm ³ /rev (0.41 in ³ /rev)	PLP 10-6,3
	8,51 cm ³ /rev (0.52 in ³ /rev)	PLP 10-8
	10,67 cm ³ /rev (0.65 in ³ /rev)	PLP 10-10

2	Drive shaft	Code
	European tapered 1:8	81
	European tapered 1:8	86
	SAE "AA" spline (9 teeth)	02
	SAE "AA" straight	30
	SAE straight	36
	Straight	29

3	Mounting flange	Code
	European	E1
	European	E7
	European	E8
	German 2 bolts	B1
	German 4 bolts	K2
	SAE "AA" 2 bolt	S0
	SAE "AA" 2-4 bolt	R9
	SAE 2-4 bolt	R8
	SAE 2 bolt	W9

4	Ports position	Code
	Side	L

Code	Ports IN/OUT	5
GERMAN FLANGED PORTS		
Side	Type	
BB/BA	PLP 10 1-1,5-2-2,5-3,15-4-5-5,8-6,3-8-10	
GAS STRAIGHT THREAD PORTS (BSPP)		
Side	Type	
GC/GC	PLP 10 1-1,5-2-2,5-3,15-4	
GD/GD	PLP 10 5-5,8-6,3-8-10	
SAE STRAIGHT THREAD PORTS (ODT)		
Side	Type	
OB/OA	PLP 10 1-1,5-2-2,5-3,15-4-5-5,8-6,3	
OC/OB	PLP 10 8-10	

Code	Combination type	6
V6	Standard	
V7	Common inlet	

Code	Rotation	7
S	Left	
D	Right	

Code	Versions - Outboard bearing options	8
0	Without outboard bearing (standard) no code	

Code	Seals (a)	9
N	Buna N (standard)	
V	Viton	

Code	Cover options (b)	10
	Cast iron mounting flange and rear cover (standard - no code)	
E	Aluminium mounting flange and cast iron rear cover	
L	Cast iron mounting flange and aluminium rear cover	
EL	Aluminium mounting flange and rear cover	

02/07.2006

HOW TO ORDER POLARIS 10 MULTIPLE PUMPS

11	Shaft seal options	Code
	Standard seal with wiper seal	D
	High back pressure seal	C1

12	Shaft arrangement	Code
	Female spline	FS

- (a) Choose the seals according to the temperature shown on page 5.
- (b) Mounting flange material on page 58 ÷ 60
Rear cover material on page 44

04/10.2020

HOW TO ORDER POLARIS 20 MULTIPLE PUMPS

1	2	3	4	5	6	7	8	9	10	11	12							
PLP 20-4	-	82	E2	-	L	EA/EA	/											
Front section																		
20-4	-			L	EA/EA	/												
Intermediate section																		
20-4	-			L	**/EA	-	S7	-	S	0	-	N	-	EL	-	C	/	FS
Rear section																		

1	Type	Pump Type
4,95 cm ³ /rev (0.30 in ³ /rev)		PLP 20-4
6,61 cm ³ /rev (0.40 in ³ /rev)		PLP 20-6,3
7,29 cm ³ /rev (0.44 in ³ /rev)		PLP 20-7,2
8,26 cm ³ /rev (0.50 in ³ /rev)		PLP 20-8
9,17 cm ³ /rev (0.56 in ³ /rev)		PLP 20-9
10,9 cm ³ /rev (0.66 in ³ /rev)		PLP 20-10,5
11,23 cm ³ /rev (0.69 in ³ /rev)		PLP 20-11,2
14,53 cm ³ /rev (0.89 in ³ /rev)		PLP 20-14
16,85 cm ³ /rev (1.03 in ³ /rev)		PLP 20-16
19,09 cm ³ /rev (1.16 in ³ /rev)		PLP 20-19
21,14 cm ³ /rev (1.29 in ³ /rev)		PLP 20-20
24,84 cm ³ /rev (1.52 in ³ /rev)		PLP 20-24,5
26,42 cm ³ /rev (1.61 in ³ /rev)		PLP 20-25
28,21 cm ³ /rev (1.72 in ³ /rev)		PLP 20-27,8
33,03 cm ³ /rev (2.01 in ³ /rev)		PLP 20-31,5

2	Drive shaft	Code
European tapered 1:8		82
German tapered 1:5		54
German tapered 1:5		55
Straight		46
SAE "A" spline (9 teeth)		03
SAE spline (10 teeth)		01
SAE "A" spline (11 teeth)		07
SAE "A" straight		31
Straight		49
Straight		50
SAE "B" spline		04
SAE "B" straight		32
DIN 54 82 spline		12
Straight (only for version 6)		48
Straight (only for version 8)		B1
Tang		95

Code	Mounting flange	3
E2	European	
B2	German	
B4	German 2 bolt	
B5	German 2 bolt	
B6	German 4 bolt	
U2	German 2 bolt	
S1	SAE "A" 2 bolt	
S2	SAE "A" 2 bolt	
S9	SAE "A" 2 bolt	
S5	SAE "B" 2 bolt	
W8	German	

Code	Ports position	4
L	Side	

Code	Ports IN/OUT	5
GERMAN FLANGED PORTS		
Side	Type	
BE/BC	PLP 20	4-6,3-7,2-8-9-10,5-11,2 14-16-19-20-24,5-25 27,8-31,5
EUROPEAN FLANGED PORTS		
Side	Type	
EA/EA	PLP 20	4-6,3-7,2-8-9-10,5-11,2
EB/EA	PLP 20	14-16-19-20-24,5-25 27,8-31,5
SAE FLANGED PORTS (SSM)		
Side	Type	
MA/MA	PLP 20	4-6,3-7,2-8-9-10,5-11,2
MB/MA	PLP 20	14-16-19-20
MC/MB	PLP 20	24,5-25-27,8-31,5
SAE FLANGED PORTS (SSS)		
Side	Type	
SA/SA	PLP 20	4-6,3-7,2-8-9-10,5-11,2
SB/SA	PLP 20	14-16-19-20
SC/SB	PLP 20	24,5-25-27,8-31,5

04/10.2020

HOW TO ORDER POLARIS 20 MULTIPLE PUMPS

5	Ports IN/OUT	Code
GAS STRAIGHT THREAD PORTS (BSPP)		
Type		Rear
4-6,3-7,2-8-9-10,5-11,2	PLP 20	GD/GD
14-16-19-20-24,5-25-27,8-31,5	PLP 20	GE/GD
SAE STRAIGHT THREAD PORTS (ODT)		
Type		Rear
4-6,3-7,2-8-9-10,5-11,2	PLP 20	OC/OC
14-16-19-20-24,5 25-27,8-31,5	PLP 20	OD/OC

6	Combination type	Code
Standard		S6
Common inlet		S7
Separate stages		Z6

7	Rotation	Code
Left		S
Right		D

8	Versions - Outboard bearing options	Code
Without outboard bearing (standard) no code		0
With outboard bearing		W8
With outboard bearing		5
With outboard bearing		7
With outboard bearing		8
With outboard bearing		9

Code	Seals (a)	9
N	Buna (standard)	
V	Viton	
T-PV	Hydrogenated buna HNBR seals with Viton-FKM shaft seals	

Code	Cover options (b)	10
	Cast iron mounting flange and rear cover (standard - no code)	
E	Aluminium mounting flange and cast iron rear cover	
L	Cast iron mounting flange and aluminium rear cover	
EL	Aluminium mounting flange and rear cover	

Code	Shaft seal options	11
D	Standard shaft seals with wiper seal	
C1	High back pressure seal	

Code	Shaft arrangement	12
FS	Female spline	

- (a) Choose the seals according to the temperature shown on page 5.
- (b) Mounting flange material on page 61 ÷ 66
Rear cover material on page 45

04/10.2020

HOW TO ORDER POLARIS 30 MULTIPLE PUMPS

1	2	3	4	5	6	7	8	9	10	11						
PLP 30-22	-	83	E3	-	L	ED/EB	/									
Front section																
30-22	-			L	ED/EB	/										
Intermediate section																
30-22	-			L	ED/EB	-	M6	-	S	O	-	N	-	C	/	FS
Rear section																

1	Type	Pump Type
	21,99 cm ³ /rev (1.34 in ³ /rev)	PLP 30-22
	26,70 cm ³ /rev (1.63 in ³ /rev)	PLP 30-27
	34,55 cm ³ /rev (2.11 in ³ /rev)	PLP 30-34
	39,27 cm ³ /rev (2.40 in ³ /rev)	PLP 30-38
	43,98 cm ³ /rev (2.68 in ³ /rev)	PLP 30-43
	51,83 cm ³ /rev (3.16 in ³ /rev)	PLP 30-51
	61,26 cm ³ /rev (3.74 in ³ /rev)	PLP 30-61
	73,82 cm ³ /rev (4.50 in ³ /rev)	PLP 30-73
	81,68 cm ³ /rev (4.98 in ³ /rev)	PLP 30-82
	91,10 cm ³ /rev (5.56 in ³ /rev)	PLP 30-90

2	Drive shaft	Code
	European tapered 1:8	83
	European tapered 1:8	84
	German tapered 1:5	56
	Straight	41
	SAE "B" spline	A8
	SAE "BB" spline	A5
	SAE "B" spline	04
	SAE "BB" spline	05
	SAE "B" straight	32
	SAE "BB" straight	33

3	Mounting flange	Code
	European	E3
	European	E4
	German	B3
	SAE "B" 2 bolt	S5
	SAE "B" 2 bolt	U3

4	Ports position	Code
	Side	L

Code	Ports IN/OUT	5
GERMAN FLANGED PORTS		
Side	Type	
BM/BL	PLP 30	22-27-34-38-43 46-51-61-73-82-90
EUROPEAN FLANGED PORTS		
Side	Type	
ED/EB	PLP 30	22-27-34-38-43 46-51-61
EF/ED	PLP 30	73-82-90
SAE FLANGED PORTS (SSM)		
Side	Type	
MB/MA	PLP 30	22
MC/MB	PLP 30	27-34
MD/MC	PLP 30	38-43-46-51
ME/MD	PLP 30	61-73-82
MF/ME	PLP 30	90
SAE FLANGED PORTS (SSS)		
Side	Type	
SB/SA	PLP 30	22
SC/SB	PLP 30	27-34
SD/SC	PLP 30	38-43-46-51
SE/SD	PLP 30	61-73-82
SF/SE	PLP 30	90
GAS STRAIGHT THREAD PORTS (BSPP)		
Side	Type	
GF/GF	PLP 30	22-27-34-38-43-46-51
GG/GF	PLP 30	61-73
GH/GG	PLP 30	82-90
SAE STRAIGHT THREAD PORTS (ODT)		
Side	Type	
OF/OD	PLP 30	22-27-34
OG/OF	PLP 30	38-43-46-51
OH/OG	PLP 30	61-73-82-90

01/10.2003

HOW TO ORDER POLARIS 30 MULTIPLE PUMPS

6	Combination type	Code
	Standard	M6

7	Rotation	Code
	Left	S
	Right	D

8	Versions - Outboard bearing options	Code
	Without outboard bearing (standard) no code	0

9	Seals (a)	Code
	Buna (standard)	N
	Viton	V

10	Shaft seal options	Code
	Standard seal with wiper seal	D
	High back pressure seal	C1

11	Shaft arrangement	Code
	Female spline	FS

- (a) Choose the seals according to the temperature shown on page 5.

04/10.2020

HOW TO ORDER POLARIS DOUBLE PUMPS DIFFERENT GROUPS

1		2		3		4		5		6		7		8		9		10		11	
PL 30-22 - 83 E3 - L ED/EB /																					
Front section																					
20-4 - L EA/EA S 0 / FS - L - N																					
Rear section																					

1		2		3		4		5		6		7		8		9		10		11	
PLP 30-22 - 83 E3 - L ED/EB - 52 /																					
Front section																					
10-1 - L BB/BA - S 0 / FS - L - N																					
Rear section																					

1		2		3		4		5		6		7		8		9		10		11	
PLP 20-4 - 82 E2 - L EA/EA - 51 /																					
Front section																					
10-1 - L BB/BA - S 0 / FS - EL - N																					
Rear section																					

1	Type	Pump Type
	The same of multiple pumps	PLP
2	Drive shaft	Code
	The same of multiple pumps	...
3	Mounting flange	Code
	The same of multiple pumps	...
4	Ports position	Code
	Side	L
5	Ports IN/OUT	Code
	The same of multiple pumps	../..
6	Combination type	Code
	PLP30/20 Standard - No code	N6
	PLP30/20 Common inlet	N7
	PLP30/20 Separate stages	Z6
	PLP30/10 Standard - No code	Q6
	PLP30/10 Common inlete	Q7
	PLP20/10 Standard - No code	T6
	PLP20/10 Common inlet	T7
	PLP20/10 Separate stages	Z6

	Code	Rotation	7
	S	Left	
	D	Right	
8	Code	Versions - Outboard bearing options	8
	...	The same of multiple pumps	
9	Code	Shaft arrangement	9
	FS	Female spline	
10	Code	Cover options (a)	10
		Cast iron mounting flange and rear cover (standard - no code)	
	E	Aluminium mounting flange and cast iron rear cover (only for PLP20/10)	
	L	Cast iron mounting flange and aluminium rear cover	
	EL	Aluminium mounting flange and rear cover (only for PLP20/10)	
11	Code	Seals	11
		The same of multiple pumps	

(a) Mounting flange material:
 PLP 20 on page 61 ÷ 66 - PLP 30 on page 67 ÷ 69
 Rear cover material:
 PLP 10 on page 44 - PLP 20 on page 45

02/07.2006

Our policy is one of continuous improvement in product. Specification of items may, therefore, be changed without notice.

ТОВ "Промислова Гідравліка": <https://promhydraulic.com.ua/ua/>
Телефонуйте: +380 (95) 670-15-32, +380 (98) 533-91-67, +380 (96) 244-48-42

PL 05 T A

Edition: 05/04.2023

Replaces: PL 04 T A



Headquarters:
CASAPPA S.p.A.
Via Balestrieri, 1
43044 Lemignano di Collecchio
Parma (Italy)
Tel. (+39) 0521 30 41 11
Fax (+39) 0521 80 46 00
E-mail: info@casappa.com
www.casappa.com

