



GEAR PUMPS

GROUP 1

MODEL MGP

SERIES K

WWW.OLEODINAMICAMOZIONI.IT

GEAR PUMPS SERIES "K" MANUFACTURED BY OLEODINAMICA MOZIONI ARE THE MOST USED IN HYDRAULIC UNITS IN THE HYDRAULIC SYSTEMS OF MOBILE MACHINES AND CONFORM TO INTERNATIONAL STANDARDS.

WE USE THE ADVANCED WORLD'S CONCEPTS – IMPROVING THE TECHNICAL CHARACTERISTICS OF THE PRODUCT, USE ONLY HIGH QUALITY MATERIALS AND HARDWARE MANUFACTURERS OF THE WORLD AT ALL STAGES OF DESIGN AND PRODUCTION. THE QUALITY MANAGEMENT SYSTEM CONFORMS INTERNATIONAL STANDARD ISO 9001: 2008.

GEAR PUMPS SERIES "K" OF OLEODINAMICA MOZIONI HAVE HIGH VOLUMETRIC AND MECHANICAL EFFICIENCY, LOW NOISE AND OPERATE RELIABLY IN A VARIETY HYDRAULIC SYSTEMS AND MOBILE MACHINERY.

- DIMENSIONS OF THE PUMPS ARE ACCORDING TO INTERNATIONAL STANDARDS SAE, DIN, EUROPEAN.
- GEAR PUMPS ARE SUPPLIED IN NEXT GROUPS: MGP1K, MGP2K, MGP2.5K, MGP3K WITH DISPLACEMENTS FROM 1 TO 90 CM³/REV.
- MAXIMUM CONTINUOUS PRESSURE UP TO 250 BAR.
- MOUNTING FLANGES AND REAR COVERS ARE PRODUCED WITH ALUMINIUM OR CAST IRON.
- BUILT-IN VALVES IN REAR COVER.
- MULTIPLE UNITS AVAILABLE WITH SEPARATED OR COMMON INLET FOR STAGES.
- PUMPS WITH BEARING SUPPORT FOR HEAVY DUTY APPLICATIONS.

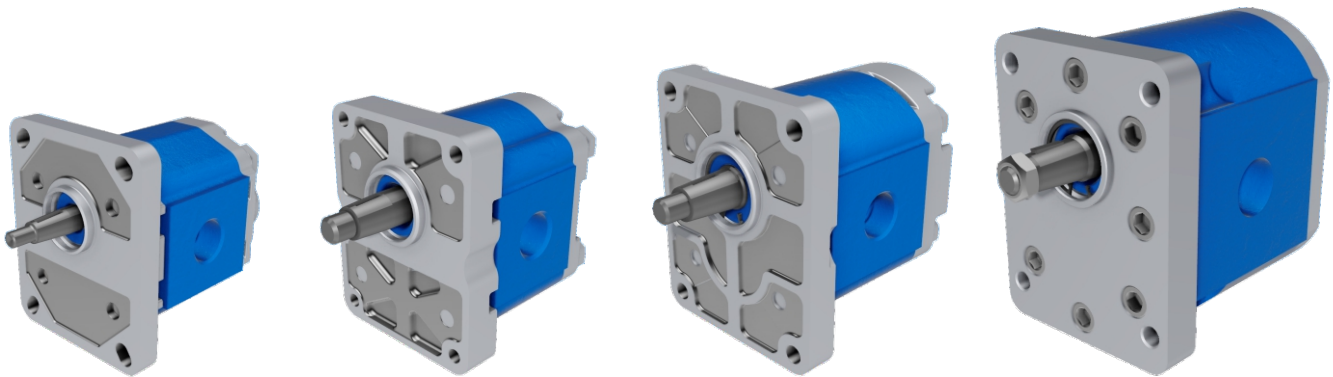

GEAR PUMPS SERIES "K" ARE MANUFACTURED WITH THRU-BOLT OF ROLLED ALUMINIUM, MOUNTING FLANGES AND REAR COVERS EITHER IN ALUMINIUM OR IN CAST IRON FOR MOBILE MACHINES, WHERE THERE ARE INCREASED REQUIREMENTS FOR THE NOISE LEVEL.

GEAR PUMPS SERIES "K" HAVE HIGH ANTI-FRICTION AND STRENGTH CHARACTERISTICS. THE SEALS REDUCE INTERNAL FLOW OF THE FLUID AND TO ACHIEVE A HIGH VOLUMETRIC EFFICIENCY.

1. DRIVE SHAFT
2. DRIVEN SHAFT
3. BEARING HOUSING
4. BODY
5. SLIDE BEARING
6. MOUNTING FLANGE
7. REAR COVER
8. COMPENSATION SEAL
9. ANTI-EXTRUSION PLATE
10. SEALING RING
11. SHAFT SEAL
12. STOP RING
13. CENTERING PIN
14. SCREW
15. WASHER

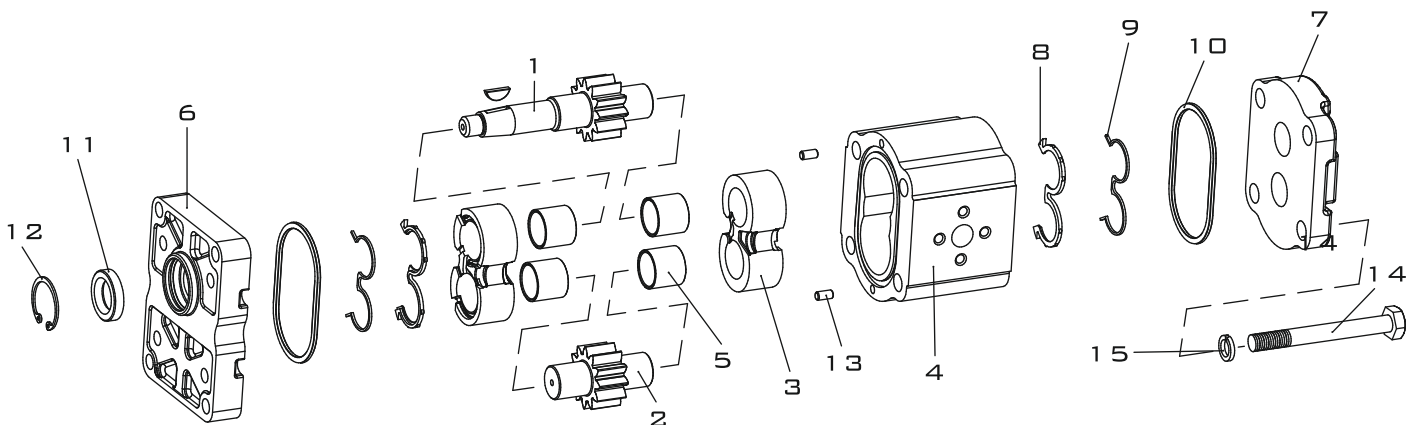



POMPE AD INGRANAGGI

MGP1K

GEAR PUMPS
GROUP 1

WORKING CONDITIONS

INLET PRESSURE (MAX.)	0.5 – 2.5 BAR
MIN. OPERATING FLUID VISCOSITY	10 MM ² /SEC
MAX. STARTING VISCOSITY (COLD START)	1000 MM ² /SEC
FLUID VISCOSITY RECOMMENDED RANGE	17 – 65 MM ² /SEC
FLUID OPERATING TEMPERATURE RANGE WITH NBR SEALS	-40 + 100 °C
FLUID OPERATING TEMPERATURE RANGE WITH FPM SEALS (VITON)	-20 + 170 °C
HYDRAULIC FLUID	MINERAL OIL
CONTAMINATION CLASS ISO 4406	18/15 (>200 BAR), 19/16 (<200 BAR)
CONTAMINATION CLASS NAS 1638	9 (>200 BAR), 10 (<200 BAR)
ACHIEVED WITH FILTER $\beta_x=75$	15 μ M (>200 BAR), 25 μ M (<200 BAR)

DEFINITION OF ROTATION DIRECTION LOOKING ON THE DRIVE SHAFT

COUNTERCLOCKWISE ROTATION

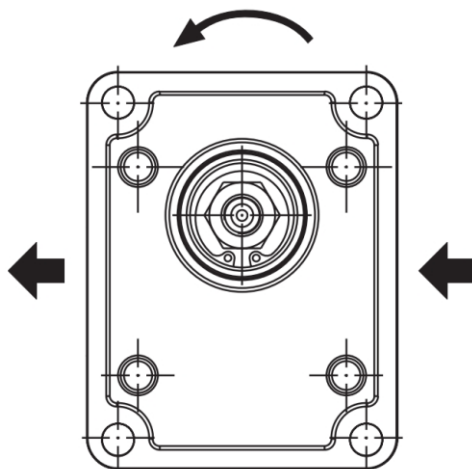

CLOCKWISE ROTATION

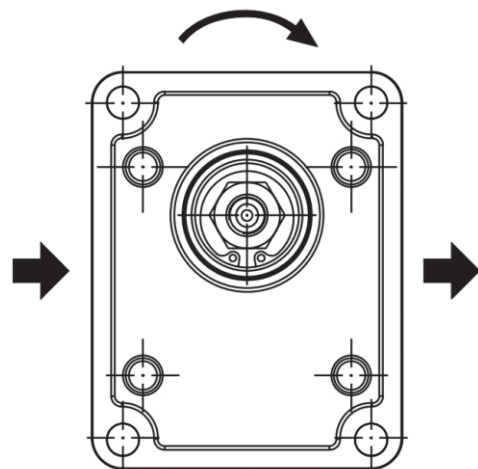

TECHNICAL DATA AND INSTALLATION DIMENSIONS

TYPE	MGP1K1	MGP1K1.2	MGP1K1.6	MGP1K2.1	MGP1K2.5	MGP1K3.2	MGP1K3.5	MGP1K4.2	MGP1K5	MGP1K6.2	MGP1K7	MGP1K8	MGP1K10
DISPLACEMENT, CM^3/REV	1,0	1,2	1,6	2,1	2,5	3,2	3,5	4,2	5,0	6,2	7,0	8,0	10,0
DIMENSION A, MM	37,7	38,4	39,9	41,8	43,3	45,9	47,0	49,6	52,6	57,2	60,2	63,6	71,0
DIMENSION B, MM	18,9	19,2	20,0	20,9	21,7	23,0	23,5	24,8	26,3	28,6	30,1	31,8	35,5
MAX. CONTINUOUS PRESSURE P_1 , BAR	250					240			230	220	210	170	140
MAX. INTERMITTENT PRESSURE P_2 , BAR	270					260			250	240	230	190	160
PEAK PRESSURE P_3 , BAR	290					280			270	260	250	210	180
MAX. SPEED N_{MAX} , MIN^{-1}	4000					3500					3200		
MIN. SPEED AT $P_1 \leq 100$ BAR, N_{MIN} , MIN^{-1}	750					650					600		
WEIGHT, KG	0,83	0,85	0,87	0,91	0,93	0,96	0,98	1,00	1,05	1,16	1,20	1,26	1,32

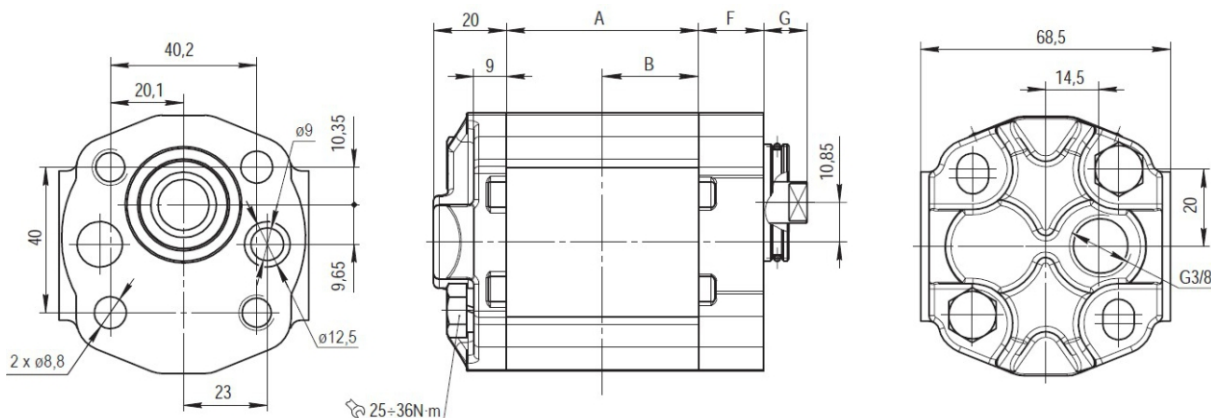
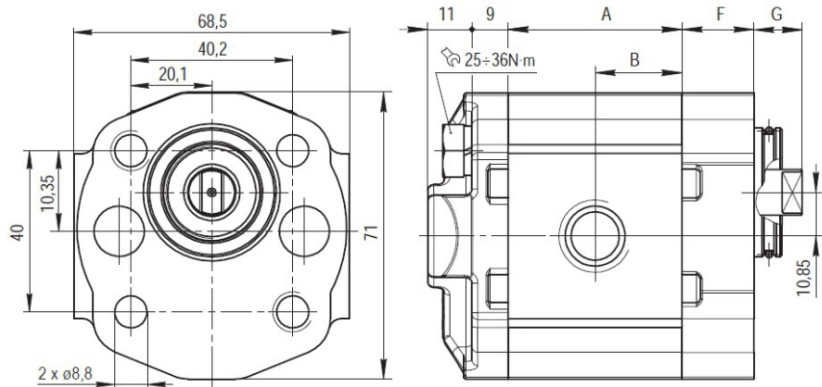
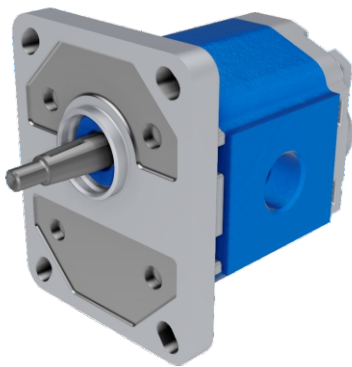

MGP1K4.2R-K210GC-A

DIMENSIONS G AND F SEE AT SECTIONS "DRIVE SHAFTS" AND "MOUNTING FLANGES"







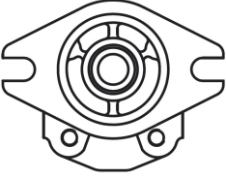
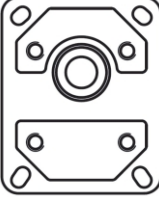
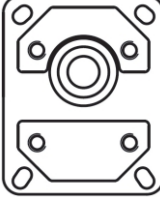

POMPE AD INGRANAGGI

MGP1K

GEAR PUMPS
GROUP 1

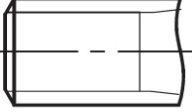
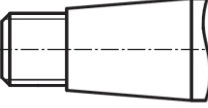
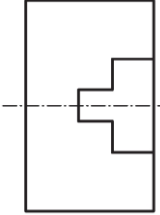
COMBINATIONS OF MOUNTING FLANGES & SHAFTS

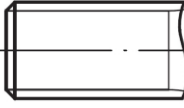
<p>MGP1K</p>	 <p>SAE "A-A" 2 BOLTS</p>	 <p>EUROPEAN ø25,4</p>	 <p>EUROPEAN ø30</p>	 <p>GERMAN 2 BOLTS (RIGHT)</p>	 <p>GERMAN 2 BOLTS (LEFT)</p>	 <p>GERMAN 2 BOLTS</p>
 <p>SAE SPLINED (8 TEETH)</p>	<p>B1 30</p>					
 <p>EUROPEAN TAPERED 1:8</p>		<p>G1 60</p>	<p>G1 70</p>			
 <p>TANG DRIVE</p>				<p>K1 10</p>	<p>K1 11</p>	<p>K1 12</p>
 <p>TANG DRIVE</p>				<p>K2 10</p>	<p>K2 11</p>	<p>K2 12</p>
 <p>DIN 5482 SPLINED (6 TEETH)</p>	<p>I1 30</p>					

THIS COMBINATIONS OF MOUNTING FLANGES AND SHAFTS ARE USED TO SERIAL PRODUCTION. THE OTHER COMBINATIONS AND DATE OF PRODUCTION, BEFORE ORDERING CLARIFY WITH THE MANUFACTURER.

SEE ALSO: MGP2K
MGP2.5K, MGP3K

DRIVE SHAFTS

MAX. TORQUE 35 N·M

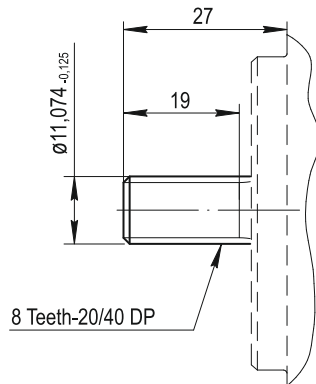

B1 – SAE SPLINED (8 TEETH)

MAX. TORQUE 20 N·M

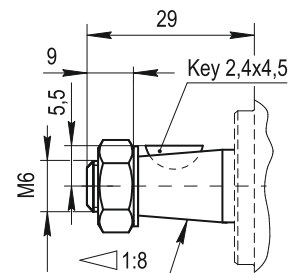

G1 – EUROPEAN TAPERED 1:8

MAX. TORQUE 20 N·M

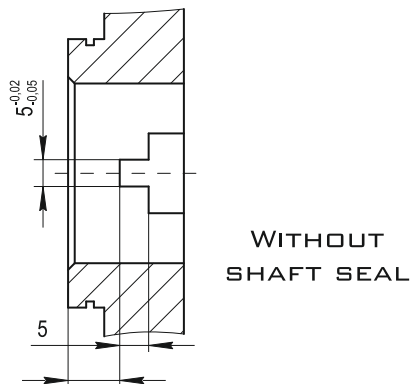

K1 – TANG DRIVE

MAX. TORQUE 20 N·M

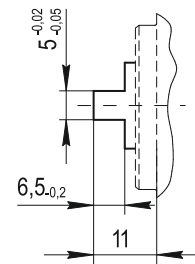

K2 – TANG DRIVE

MAX. TORQUE 20 N·M

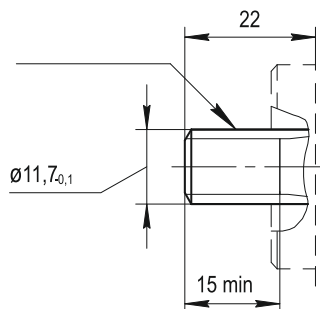

I1 – DIN 5482 SPLINED (6 TEETH)

THE TORQUE ON THE OUTPUT SHAFT FOR CODES G1 K1, K2 SHOULD BE RESTRICTED OUTLET PRESSURE.

MOUNTING FLANGES

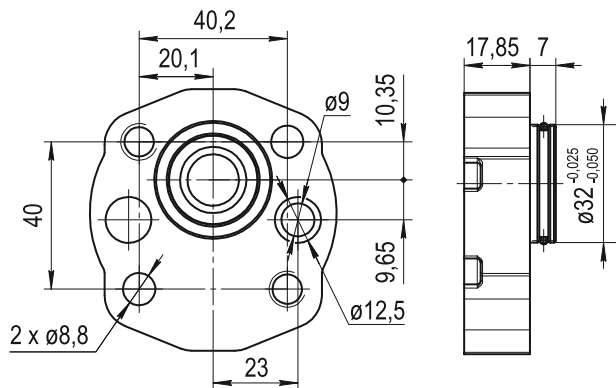

10 - GERMAN 2 BOLTS (RIGHT)

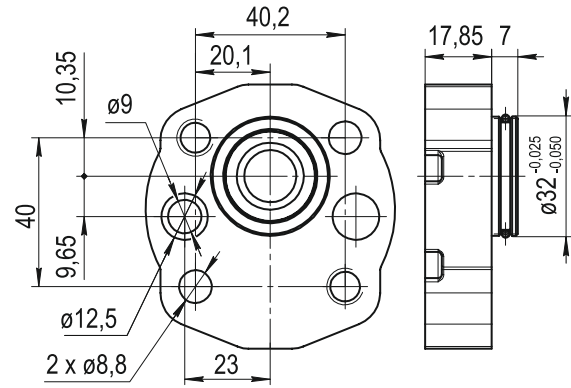

11 - GERMAN 2 BOLTS (LEFT)

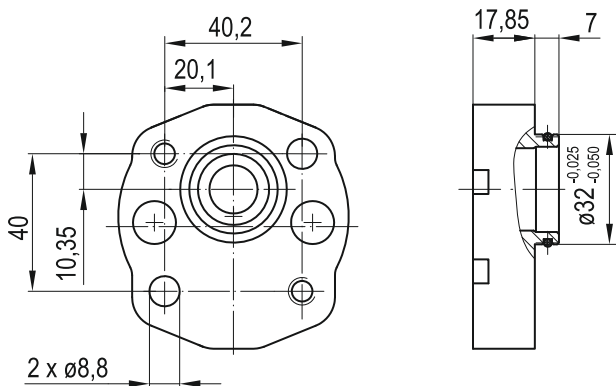

12 - GERMAN 2 BOLTS

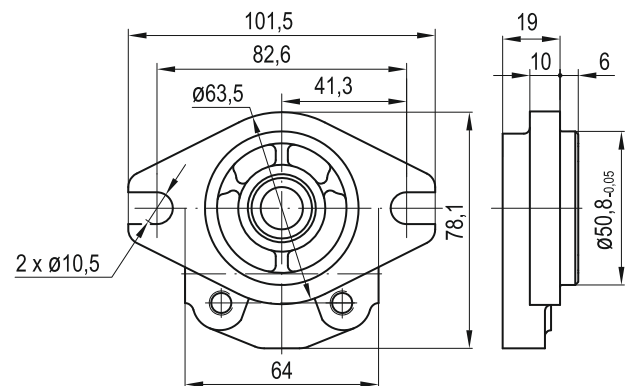

30 - SAE "A-A" 2 BOLTS

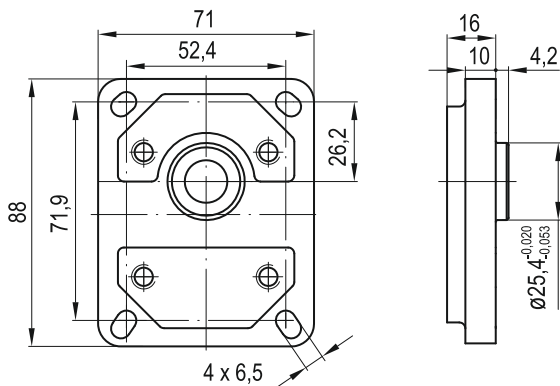

60 - EUROPEAN ø25,4

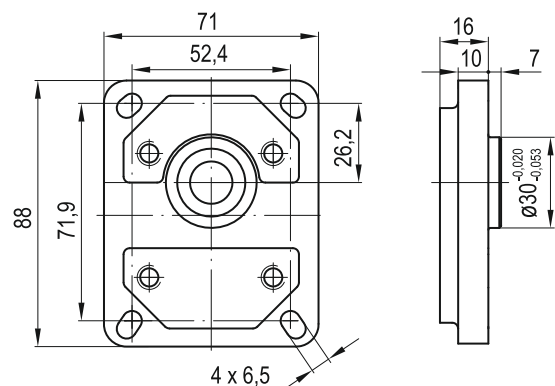

70 - EUROPEAN ø30

MGP1K

GEAR PUMPS
GROUP 1

POMPE AD INGRANAGGI



PORTS

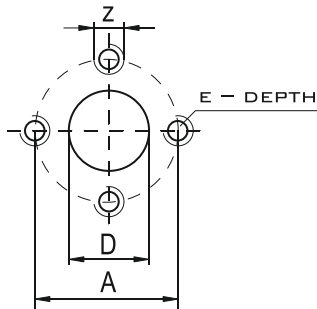

B - EUROPEAN FLANGE

TYPE	INLET				OUTLET			
	D	A	Z	E	D	A	Z	E
MGP1K1÷10	13	30	M6	12	13	30	M6	12

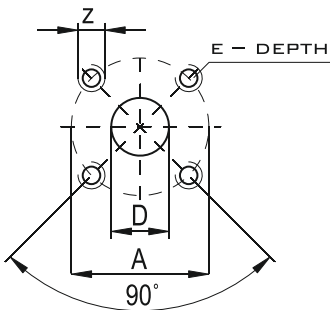

C - GERMAN FLANGE

TYPE	INLET				OUTLET			
	D	A	Z	E	D	A	Z	E
MGP1K1÷10	13	30	M6	12	13	30	M6	12

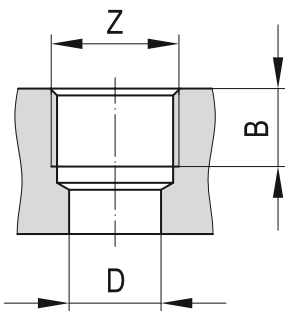

E - METRIC THREADED

TYPE	INLET			OUTLET		
	Z	B	D	Z	B	D
MGP1K1÷10	M18x1,5	15	13	M14x1,5	15	13

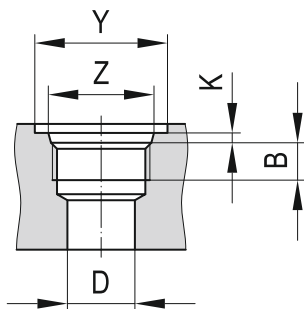

F - SAE THREADED

TYPE	INLET					OUTLET				
	Z	B	D	Y	K	Z	B	D	Y	K
MGP1K1÷5	9/16-18 UNF	15	12	26	2,5	9/16-18 UNF	15	12	26	2,5
MGP1K6.2÷10			13	32				3/4-16 UNF	13	



POMPE AD INGRANAGGI

MGP1K

GEAR PUMPS
GROUP 1

PORTS

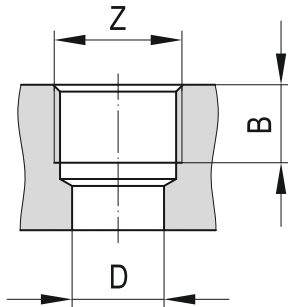

G - GAS THREADED (BSPP)

TYPE	INLET			OUTLET		
	Z	B	D	Z	B	D
MGP1K1÷5	3/8" GAS	15	12	3/8" GAS	15	12
MGP1K6.2÷10	1/2" GAS		13	1/2" GAS		13

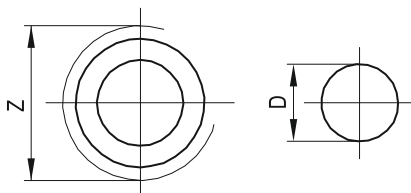

PORT POSITIONS ONLY FOR BACK-FRONT OR SIDE-FRONT
(CODE "A" OR "C")

GA - GAS THREADED (BSPP)

TYPE	INLET	OUTLET
	Z	D
MGP1K1÷10	1/4" GAS	9

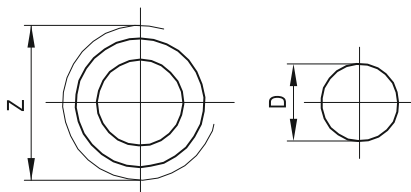

PORT POSITIONS ONLY FOR BACK-FRONT OR SIDE-FRONT
(CODE "A" OR "C")

GC - GAS THREADED (BSPP)

TYPE	INLET	OUTLET
	Z	D
MGP1K1÷10	3/8" GAS	9

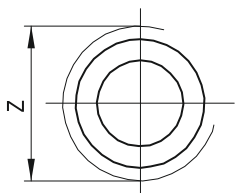

PORT POSITIONS ONLY FOR BACK INLET AND BACK OUTLET
(CODE "D")

GD - GAS THREADED (BSPP)

TYPE	INLET	OUTLET
	Z	
MGP1K1÷10	3/8" GAS	1/4" GAS



CHARACTERISTIC CURVES

CHARACTERISTIC CURVES CARRIED OUT WITH OIL VISCOSITY AT 30 MM²/SEC,
OIL TEMPERATURE AT 50 °C AND MAX. CONTINUOUS PRESSURES FOR EACH TYPE.

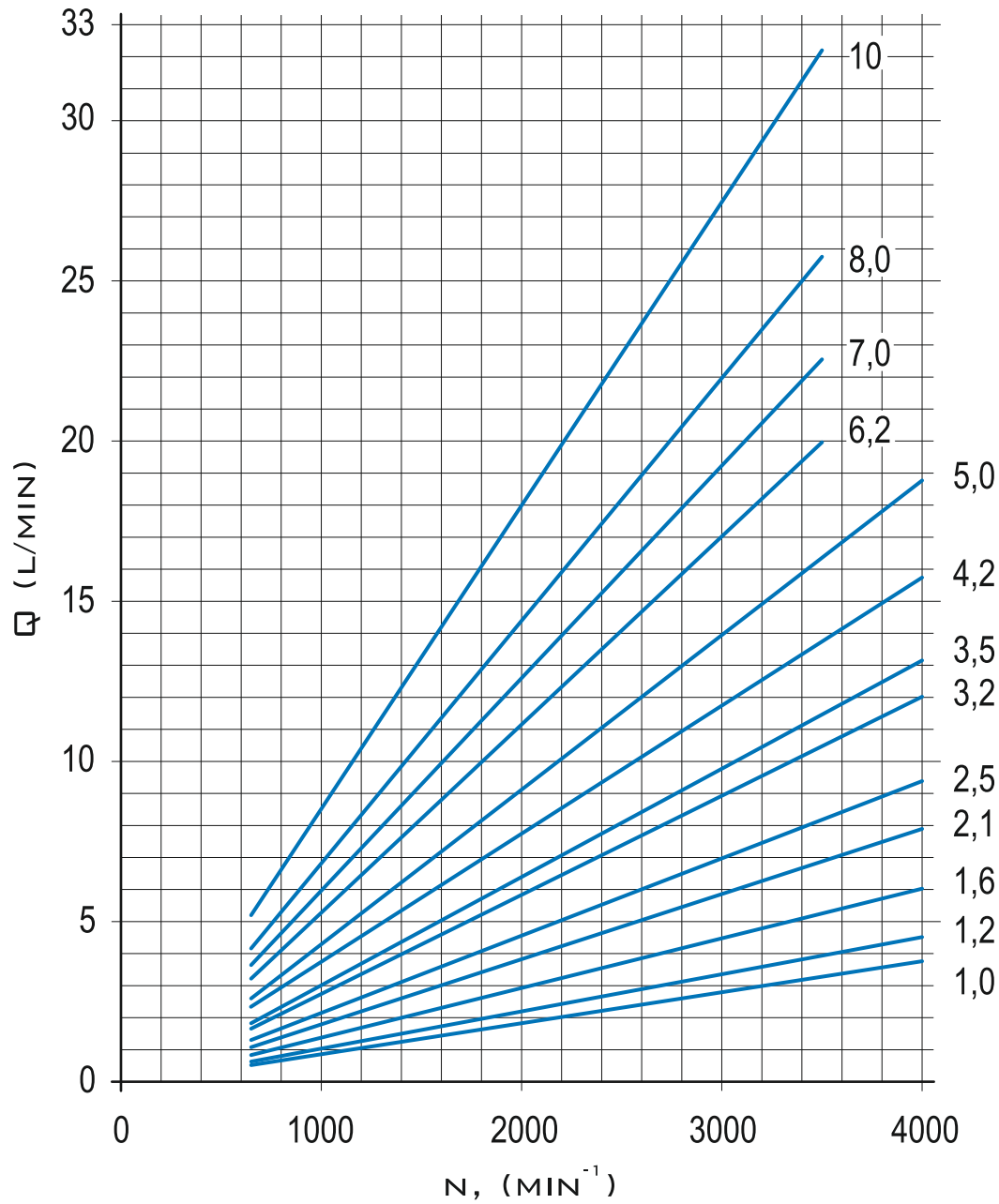



CHARACTERISTIC CURVES

CHARACTERISTIC CURVES CARRIED OUT WITH OIL VISCOSITY AT 30 MM²/SEC AND OIL TEMPERATURE AT 50 °C.

MGP1K1

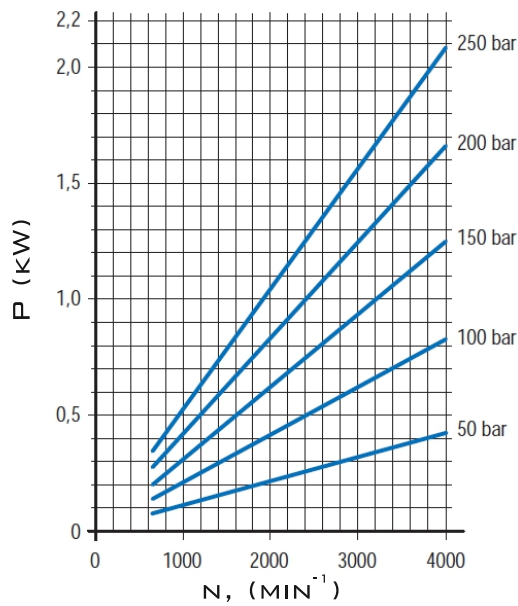

MGP1K1.2

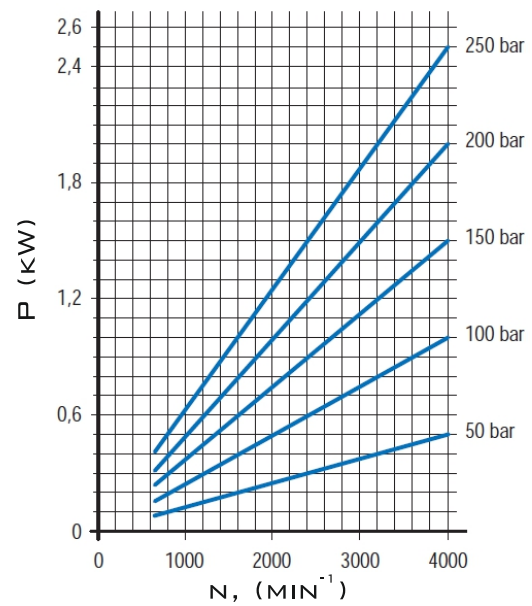

MGP1K1.6

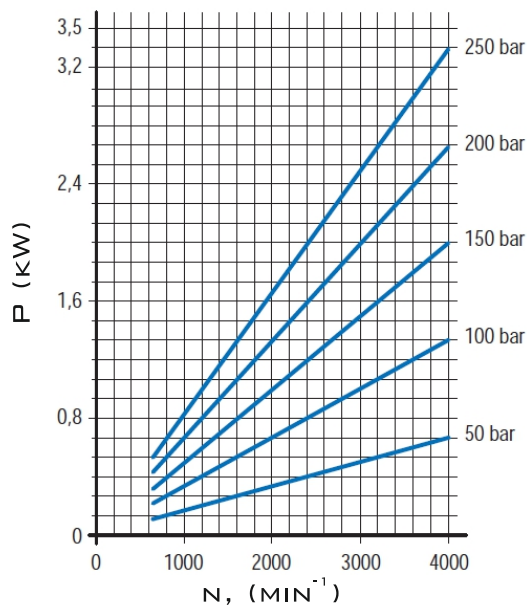

MGP1K2.1

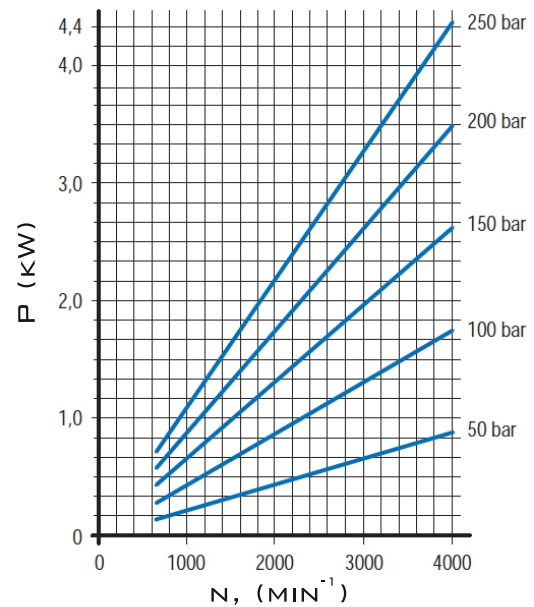



CHARACTERISTIC CURVES

CHARACTERISTIC CURVES CARRIED OUT WITH OIL VISCOSITY AT 30 MM²/SEC AND OIL TEMPERATURE AT 50 °C.

MGP1K2.5

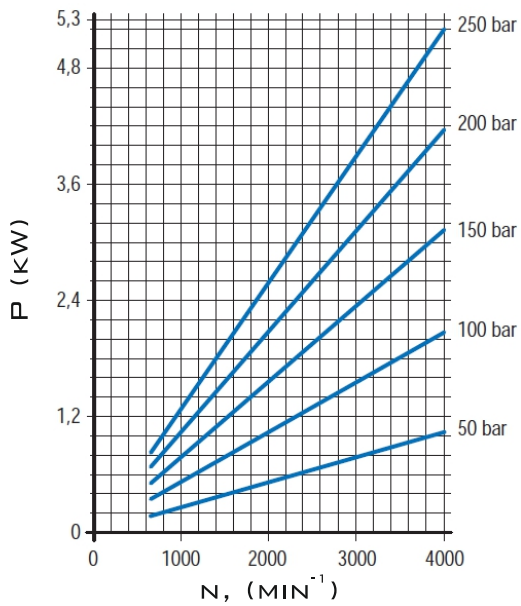

MGP1K3.2

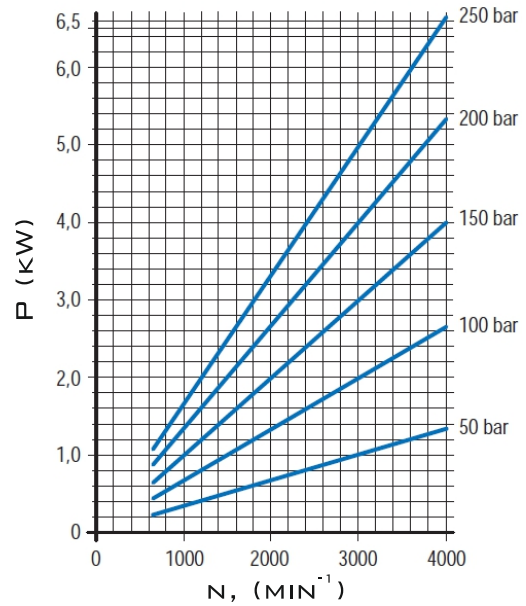

MGP1K3.5

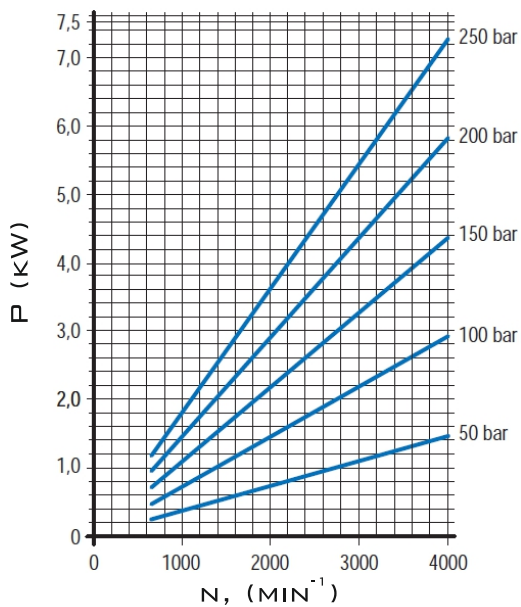

MGP1K4.2

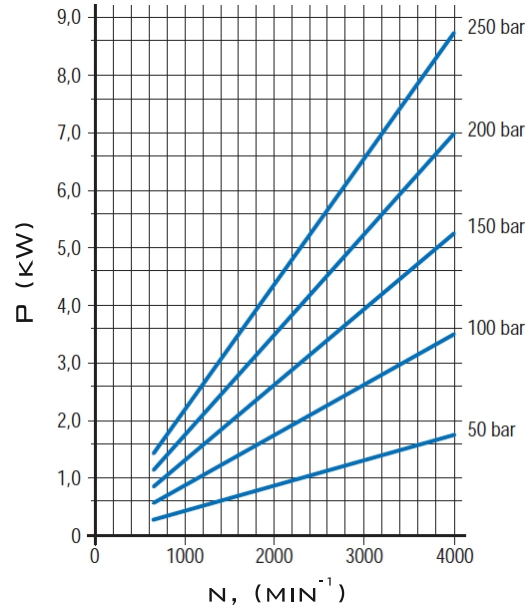



CHARACTERISTIC CURVES

CHARACTERISTIC CURVES CARRIED OUT WITH OIL VISCOSITY AT 30 MM²/SEC AND OIL TEMPERATURE AT 50 °C.

MGP1K5

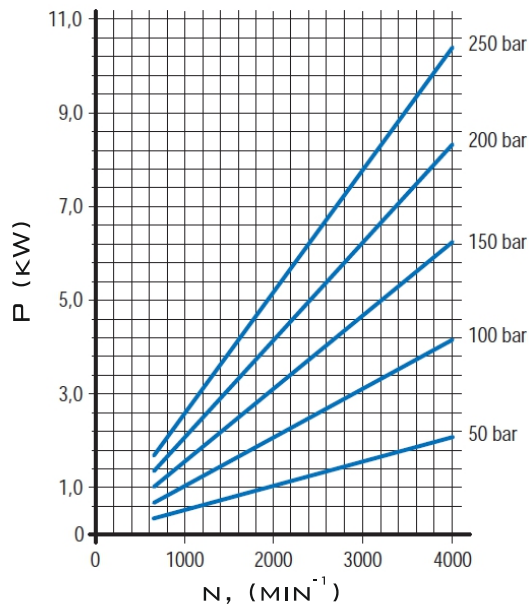

MGP1K6.2

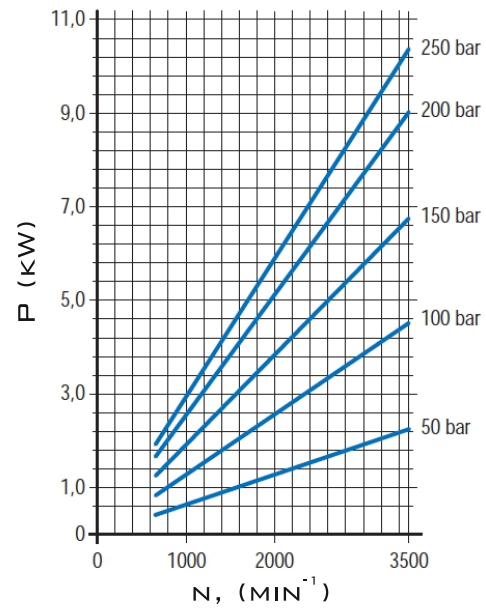

MGP1K7

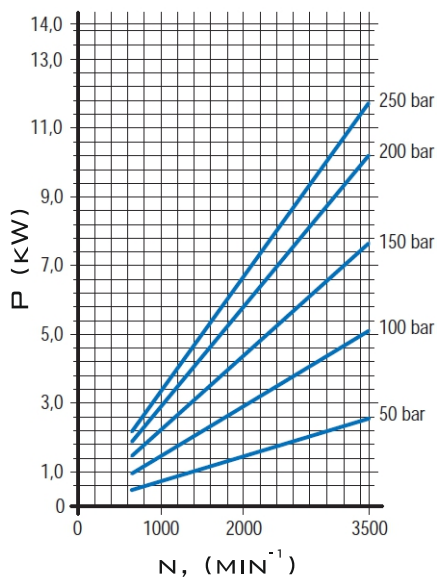

MGP1K8

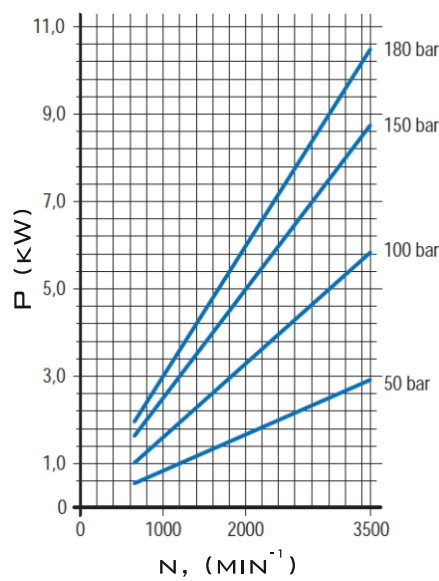

MGP1K10

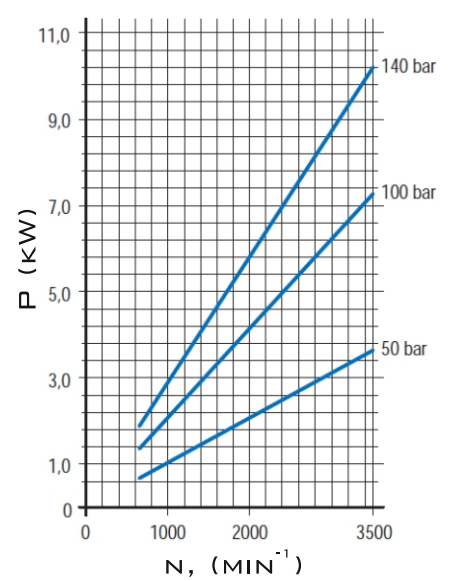

INSTRUCTIONS OF ROTATION CHANGING

PROCESS OF CHANGE DIRECTION SHOWN AT THE EXAMPLE FOR PUMP WITH CLOCKWISE ROTATION.

STEP 1

- UNSCREW AND REMOVE THE SCREWS COMPLETELY.
- PUT THE PUMP MOUNTING FLANGE UP.
- LUBRICATE THE DRIVE SHAFT WITH GREASE TO PREVENT DAMAGE TO THE SHAFT SEAL.

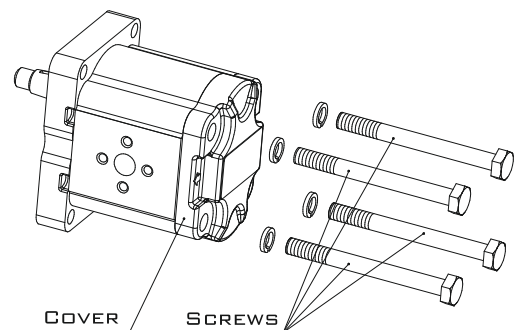

STEP 2

- REMOVE THE MOUNTING FLANGE.
- VERIFY THAT THE COMPENSATION SEAL IS CORRECTLY LOCATED IN THE BODY SEAT.

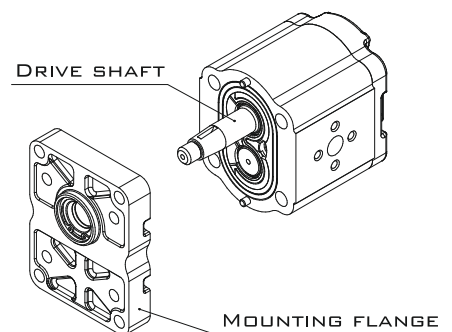

STEP 3

- MARK THE POSITION OF THE BEARING HOUSING (WITH MARKER) RELATIVE TO THE BODY.
- REMOVE THE BEARING HOUSING AND THE DRIVE SHAFT TAKING CARE TO AVOID DRIVEN SHAFT AXIAL SHIFTS.

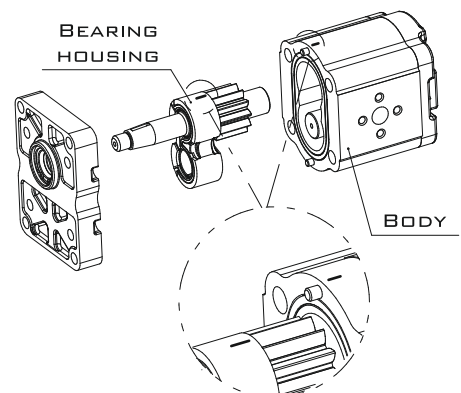

INSTRUCTIONS OF ROTATION CHANGING

PROCESS OF CHANGE DIRECTION SHOWN AT THE EXAMPLE FOR PUMP WITH CLOCKWISE ROTATION.

STEP 4

- DRAW OUT THE DRIVEN SHAFT FROM ITS HOUSING.
- RE-LOCATE THE DRIVEN SHAFT IN THE POSITION PREVIOUSLY OCCUPIED BY THE DRIVE SHAFT.

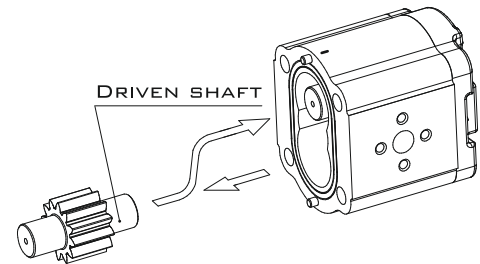

STEP 5

- RE-LOCATE THE DRIVE SHAFT IN THE POSITION PREVIOUSLY OCCUPIED BY THE DRIVEN SHAFT.

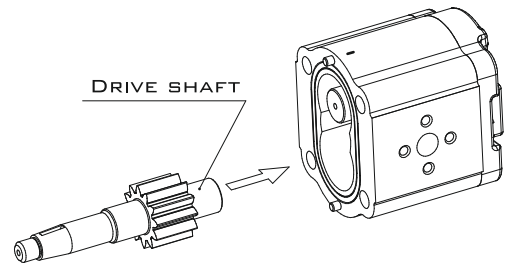

STEP 6

- REPLACE THE BEARING HOUSING TAKING CARE THAT:
 - MARKS SHALL BE LOCATED AS IN THE PICTURE.
 - COMPENSATION SEAL AND ANTI-EXTRUSION PLATE ARE CORRECTLY LOCATED.

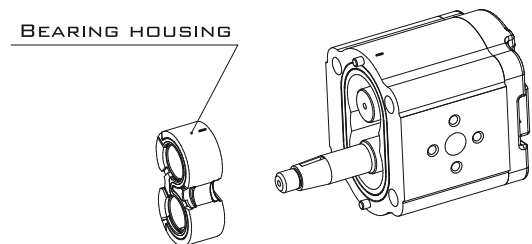

STEP 7

- CLEAN BODY AND MOUNTING FLANGE.
- REFIT THE MOUNTING FLANGE, TURNED 180° FROM ITS ORIGINAL POSITION.
- REPLACE THE CLAMP SCREWS AND TIGHTEN (TORQUE – SEE SECTION “TECHNICAL DATA”).
- CHECK THAT THE SHAFT ROTATES FREELY.

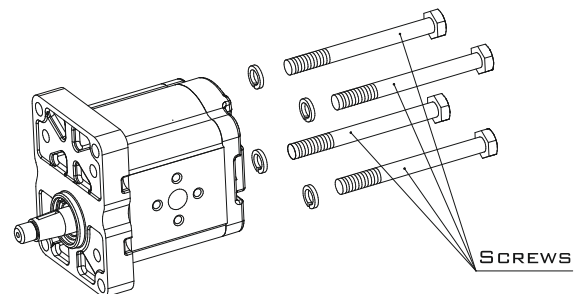

MGP1K

GEAR PUMPS
GROUP 1

POMPE AD INGRANAGGI



ORDER CODE

MGP 1 K

GROUP 1

SERIES K

1 = 1,0 CM³/REV
1.2 = 1,2 CM³/REV
1.6 = 1,6 CM³/REV
2.1 = 2,1 CM³/REV
2.5 = 2,5 CM³/REV
3.2 = 3,2 CM³/REV
3.5 = 3,5 CM³/REV
4.2 = 4,2 CM³/REV
5 = 5,0 CM³/REV
6.2 = 6,2 CM³/REV
7 = 7,0 CM³/REV
8 = 8,0 CM³/REV
10 = 10,0 CM³/REV

R = CLOCKWISE ROTATION
L = COUNTERCLOCKWISE ROTATION

DRIVE SHAFTS:
B1 = SAE SPLINED (8 TEETH)
G1 = EUROPEAN TAPERED 1:8
K1 = TANG DRIVE
K2 = TANG DRIVE
I1 = DIN 5482 SPLINED (6 TEETH)

NO CODE = NBR SEALS
V = FKM SEALS

PORTS POSITION:
NO CODE = SIDE INLET - SIDE OUTLET
A = BACK INLET - FRONT OUTLET
B = BACK INLET - SIDE OUTLET
C = SIDE INLET - FRONT OUTLET
D = BACK INLET - BACK OUTLET

PORTS:
B = EUROPEAN FLANGE
C = GERMAN FLANGE
E = METRIC THREADED
F = SAE THREADED
G = GAS THREADED (BSPP)
GA = GAS THREADED (BSPP)
GC = GAS THREADED (BSPP)
GD = GAS THREADED (BSPP)

MOUNTING FLANGES:
10 = GERMAN 2 BOLTS (RIGHT)
11 = GERMAN 2 BOLTS (LEFT)
12 = GERMAN 2 BOLTS
30 = SAE "A-A" 2 BOLTS
60 = EUROPEAN Ø25,4
70 = EUROPEAN Ø30