



VALVOLE DI PRESSIONE

DBE(E)/DBEM(E)

PROPORTIONAL RELIEF VALVE

DBE VALVE IS A PILOT OPERATED PRESSURE RELIEF VALVE. IT IS USED TO CONTINUOUSLY SET THE PRESSURE IN HYDRAULIC SYSTEMS BY ELECTRICAL SIGNAL.

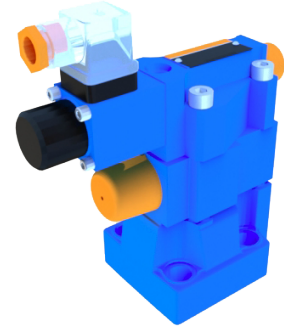

TECHNICAL DATA

FLUID		MINERAL OIL SUITABLE FOR NBR AND FKM SEAL		
		PHOSPHATE ESTER FOR FKM SEAL		
FLUID TEMPERATURE RANGE	°C	-30 TO +80 (NBR SEAL)		
		-20 TO +80 (FKM SEAL)		
VISCOSITY RANGE	MM <sup>2</sup> /S	2.8 TO 380		
DEGREE OF CONTAMINATION		MAXIMUM PERMISSIBLE DEGREE OF FLUID CONTAMINATION: CLASS 9. NAS 1638 OR 20/18/15, ISO4406		
MAX. OPERATING PRESSURE PORT A, B, X	BAR	315		
MAX.SETTING PRESSURE	BAR	50; 100; 200; 315		
MIN.SETTING PRESSURE		IN RELATION TO FLOW (Q), SEE CHARACTERISTIC CURVES		
PRESSURE AT ZERO COMMAND VALUE		= MIN.SETTING PRESSURE		
RETURN OIL PRESSURE PORT Y	BAR	SEPARATE AND AT ZERO PRESSURE TO TANK		
MAX. PRESSURE SAFETY (INFINITELY ADJUSTABLE)		SETTING PRESSURE	PRESSURE RANGE UNDER MAX. SAFETY PRESSURE	
		50 BAR	10-60 <sup>+20</sup> BAR	
		100 BAR	10-120 <sup>+20</sup> BAR	
		200 BAR	10-220 <sup>+20</sup> BAR	
		315 BAR	10-340 <sup>+20</sup> BAR	
MAX. PRESSURE SAFETY SETTING CONDITION		WHEN RATED PRESSURE IS 50 BAR, BETWEEN 60 BAR AND 80 BAR		
		WHEN RATED PRESSURE IS 100 BAR, BETWEEN 120 BAR AND 140 BAR		
		WHEN RATED PRESSURE IS 200 BAR, BETWEEN 220 BAR AND 240 BAR		
		WHEN RATED PRESSURE IS 315 BAR, BETWEEN 340 BAR AND 360 BAR		
NOMINAL SIZE		10	25	32
MAX. FLOW-RATE	L/MIN	200	400	600
PILOT OIL (FOR PILOT VALVE)	L/MIN	0.7 TO 2		
LINEARITY		±3.5%		
REPEATABILITY		< ±2%		
HYSTERESIS		WITH SHIMMY		WITHOUT SHIMMY
		±1.5% P MAX (200HZ, AMPLITUDE 200MASSL)		±4.5% P MAX
SHIFTING TIME		30~150MS (UNDEPENDENT WITH THE SYSTEM)		

## SYMBOLS

FOR EXTERNAL CONTROL ELECTRONICS:

TYPE DBEM...-7XJ/...Y...

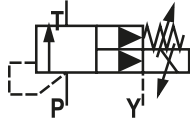

TYPE DBEM...-7XJ/...XY...

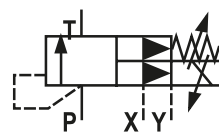

WITH INTEGRATED ELECTRONICS:

TYPE DBEME...-7XJ/...Y...

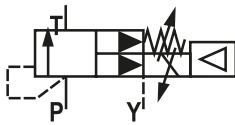

TYPE DBEM...-7XJ/...XY...

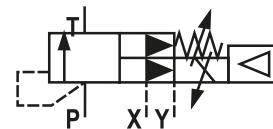

THE VALVE CONSISTS OF A PILOT VALVE (1) WITH PROPORTIONAL SOLENOID (2) AND THE MAIN VALVE (3) WITH MAIN SPOOL INSERT (4).

## TYPE DBE

THE PRESSURE LIMIT IS IN RELATION TO THE ELECTRICAL CURRENT VALUE AND SET BY THE PROPORTIONAL SOLENOID (2). THE SYSTEM PRESSURE IS APPLIED TO THE MAIN SPOOL (4). AT THE SAME TIME THE PRESSURE IS APPLIED TO THE SPRING LOADED SIDE OF THE MAIN SPOOL (4) AND THE PILOT POPPET (6) VIA ORIFICE (5) AT THE PILOT VALVE (1). IF THE HYDRAULIC FORCE EXCEEDS THE SOLENOID FORCE, THE PILOT POPPET (6) OPENS. PILOT FLUID CAN FLOW BACK TO TANK AND PRESSURE DROP CAUSED BY THE ORIFICES EFFECTS THE MAIN SPOOL (4). THEN MAIN SPOOL (4) OPENS THE CHANNEL FROM PUMP TO TANK.

## TYPE DBEM

OPTIONALLY THE VALVE CAN BE SUPPLIED WITH AN ADDITIONAL SPRING LOADED PILOT CONTROL VALVE (7) FOR MAXIMUM PRESSURE SAFETY (REDUNDANT PRESSURE SAFETY).

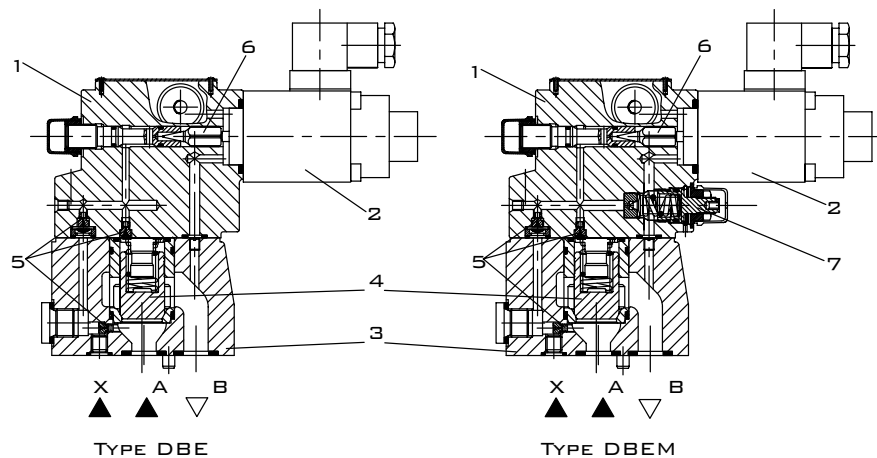



CHARACTERISTIC CURVES

(MEASURED AT  $\vartheta_{oil} = 40^{\circ}C \pm 5^{\circ}C$ , USING HLP46)

OPERATING PRESSURE IN RELATION TO THE FLOW

MIN. SETTING PRESSURE IN RELATION TO THE FLOW

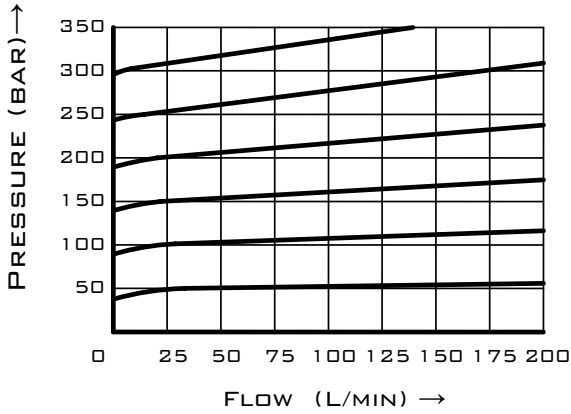

DBE10

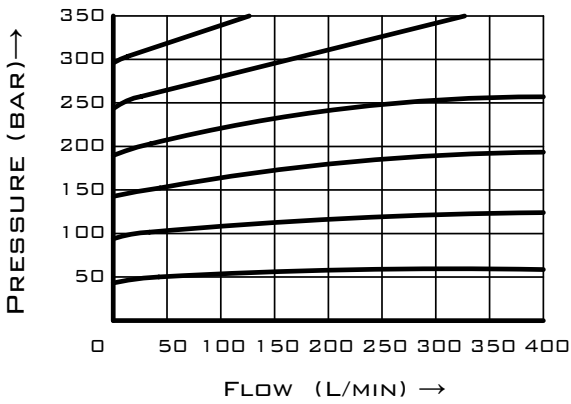
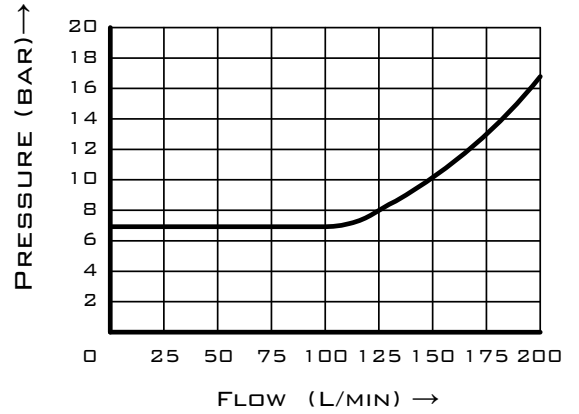

DBE20

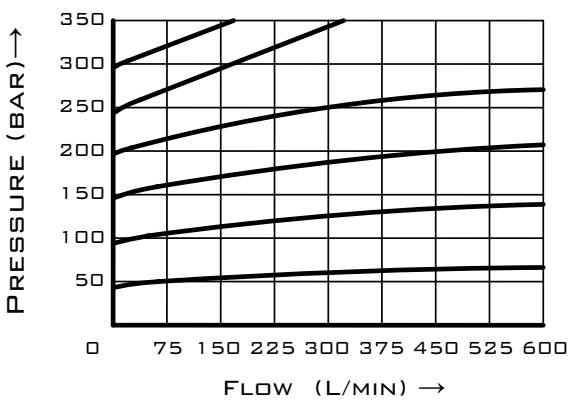
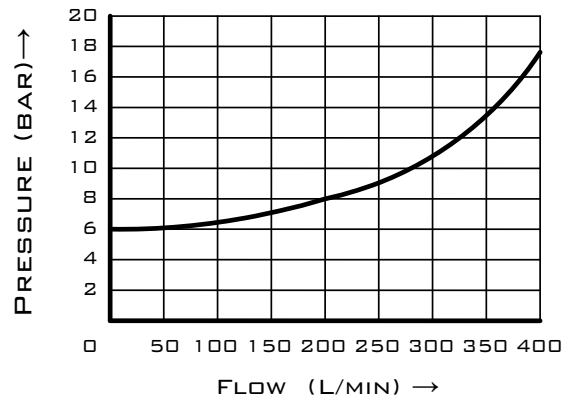

DBE30

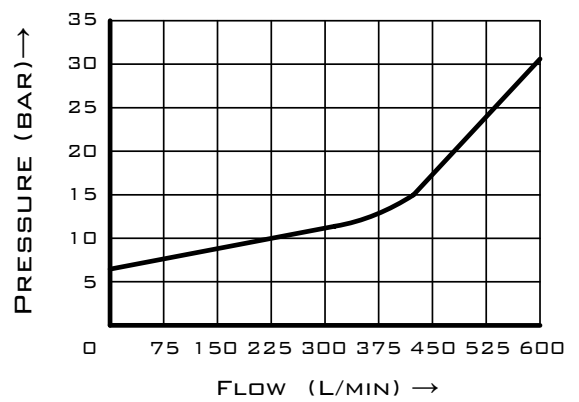



## CHARACTERISTIC CURVES

(MEASURED AT  $\vartheta_{oil} = 40^{\circ}C \pm 5^{\circ}C$ , USING HLP46)

INPUTTING PRESSURE/CURRENT DEMAND CURVE TYPE DBE10, 20 AND 30/DBET

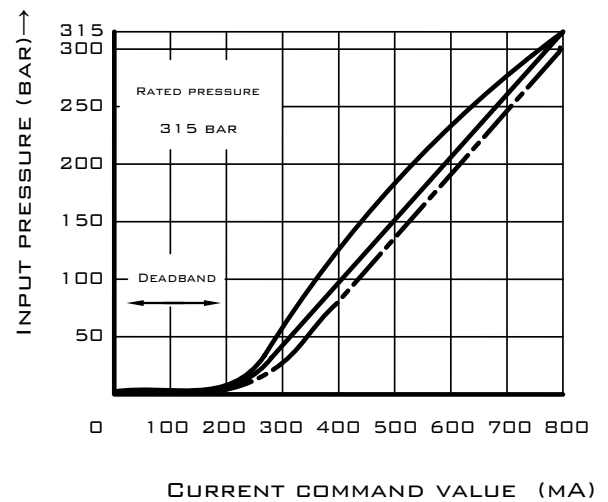
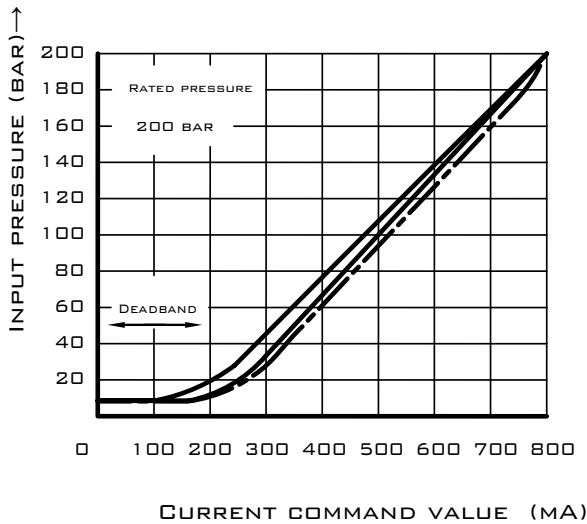
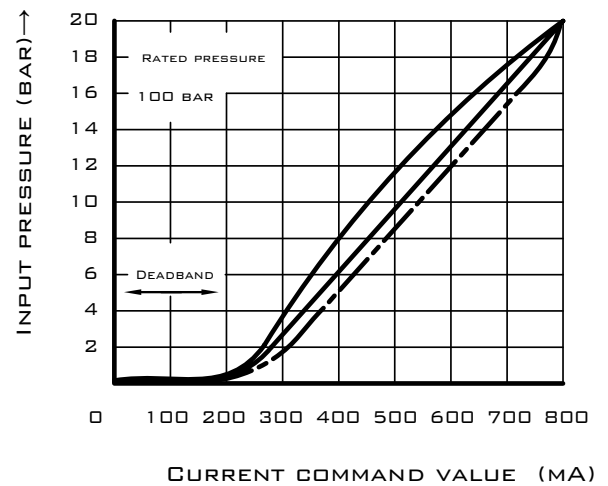
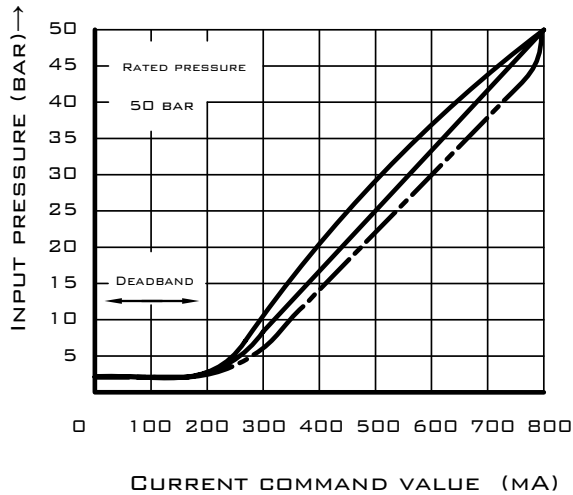

MEASURED UNDER FLOW 27 L/MIN OF TYPE DBE10, 20 AND 30.

MEASURED UNDER FLOW 0.8 L/MIN OF TYPE DBET.

— WITH SHIMMY  
 - - - WITHOUT SHIMMY



UNIT DIMENSIONS

PRESSURE RELIEF VALVE OF TYPE DBE/DBEM

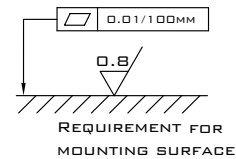
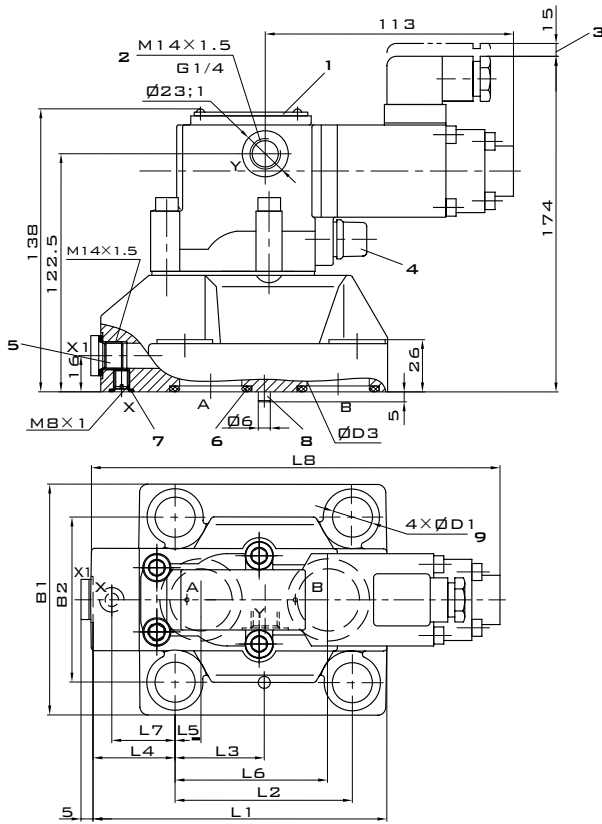

- 1 - NAME PLATE
- 2 - (PORT Y) PILOT OIL DRAIN ALWAYS EXTERNAL AND SEPARATE TO TANK AT ZERO PRESSURE.
- 3 - SPACE REQUIRED TO REMOVE PLUG-IN CONNECTOR.
- 4 - MAX. PRESSURE LIMITATION
- 5 - EXTERNAL PILOT SUPPLY (X AND X1, OPTIONAL)
- 6 - O-RING (PORT A AND B)
- 7 - O-RING 9.25X1.78 (PORT X)
- 8 - LOCATING PIN
- 9 - FIXING SCREW HOLE

TYPE	B1	B2	WEIGHT	O-RING (PORT A AND PORT B)
DWEM DWE 10	78	53.8	4.4 KG	17.12X2.62
DWEM DWE 20	100	70	4.8 KG	28.17X3.53
DWEM DWE 30	115	82.6	7.1 KG	34.52X3.53

TYPE	L1	L2	L3	L4	L5	L6
DWEM DWE 10	91	53.8	22.1	27.5	22.1	47.5
DWEM DWE 20	116	66.7	33.4	33.3	11.1	55.6
DWEM DWE 30	147.5	588.9	44.5	41	12.7	76.2

TYPE	L7	L8	D1	D2	D3	D4
DWEM DWE 10	0	176.5	14	M12	6	12
DWEM DWE 20	23.8	190	18	M16	5	22
DWEM DWE 30	31.8	200	20	M18	7	30

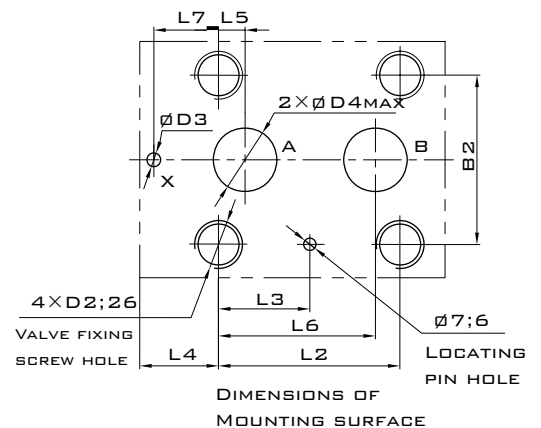



## UNIT DIMENSIONS

### PLUG-IN VALVE

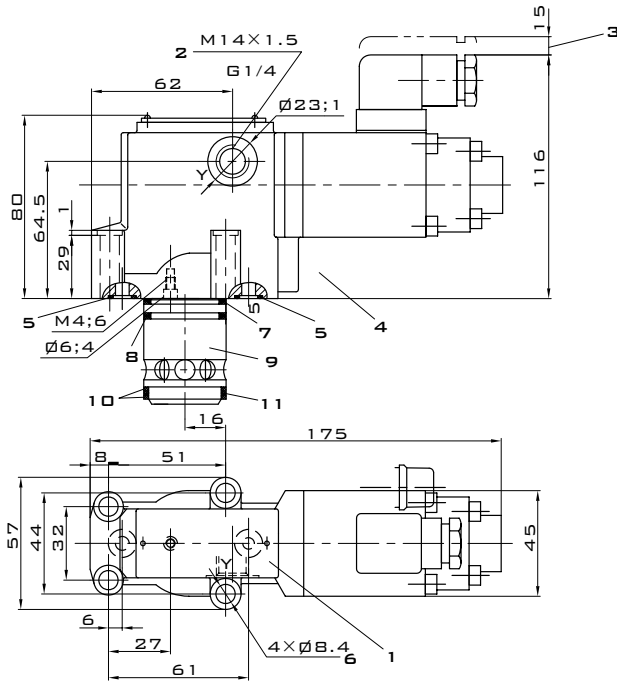

- 1 - NAME PLATE
- 2 - (PORT Y) PILOT OIL DRAIN ALWAYS EXTERNAL AND SEPARATE TO TANK AT ZERO PRESSURE
- 3 - SPACE REQUIRED TO REMOVE PLUG-IN CONNECTOR
- 4 - MAX. PRESSURE LIMITATION
- 5 - O-RING 9.25×1.78( PORT X AND Y)
- 6 - FIXING SCREW HOLE
- 7 - O-RING 28×2.65
- 8 - O-RING 28×1.8
- 9 - MAIN SPOOL ASSEMBLY
- 10 - RETAINING RING 28.4×32×0.8
- 11 - O-RING 27.3×2.4
- 12 - RETAINING RING AND O-RING SHALL BE FIXED ONTO THE HOLE BEFORE FIXING THE MAIN SPOOL
- 13 - THE THROTTLE SHALL BE ORDERED SEPARATELY

SIZE	D1	D2	D3	MAIN SPOOL ASSEMBLY CODE		VALVE FIXING SCREW	TIGHTING TOUQUE	WEIGHT
10	10	40	10	307341 (NBR)	307342 (FKM)	4-M8X40 INTERNAL HEXAGON GB/T70.1-10.9	20NM	2.9KG
20	25	45	25					
30	32	45	32					

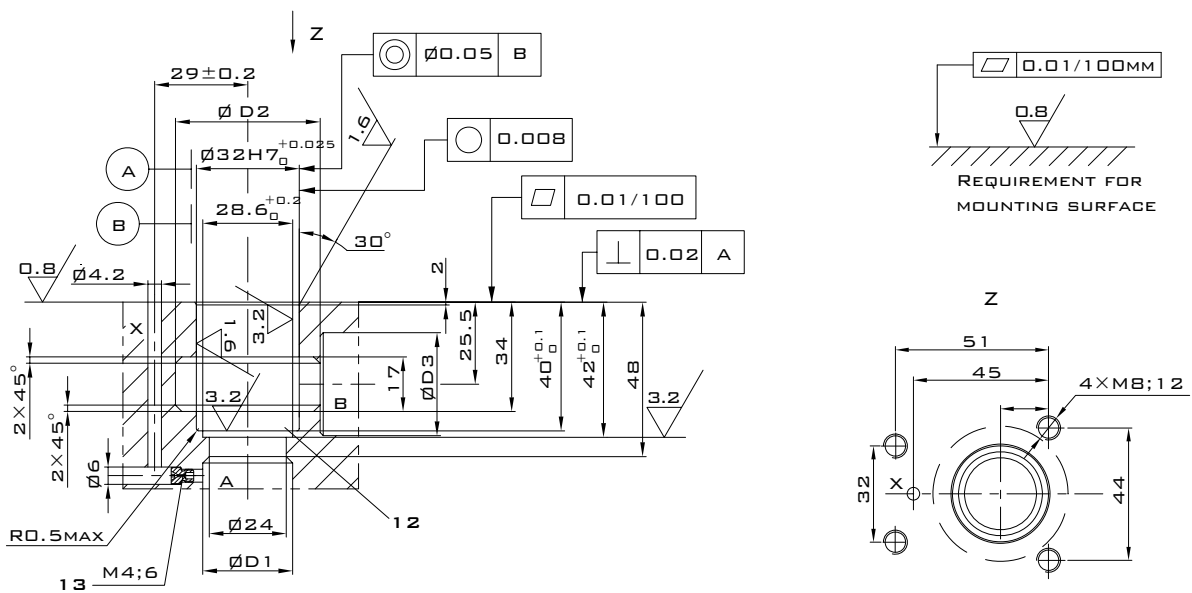



VALVOLE DI PRESSIONE

DBE(E)/DBEM(E)

PROPORTIONAL RELIEF VALVE

UNIT DIMENSIONS

PRESSURE RELIEF VALVE AS REMOTE CONTROLLER OF VALVE TYPE DBET/DBEMT  
PILOT VALVE WITHOUT MAIN SPOOL ASSEMBLY OF VALVE TYPE DBEC/DBEMC

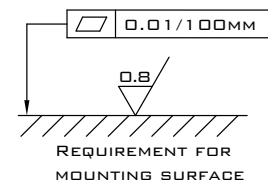
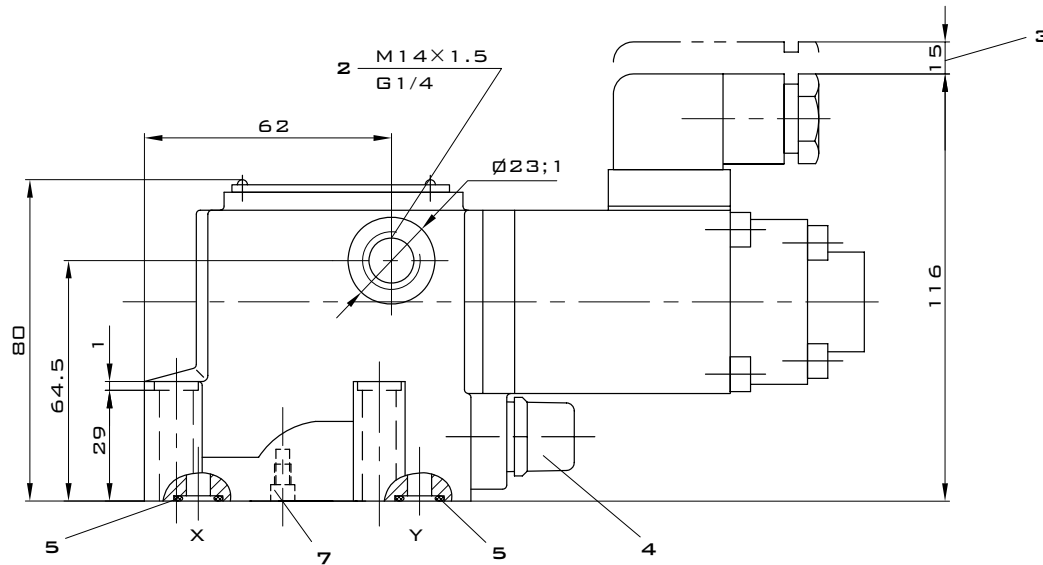

- 1 - NAME PLATE
- 2 - PILOT OIL DRAIN PORT, OPTIONAL
- 3 - SPACE REQUIRED TO REMOVE PLUG-IN CONNECTOR
- 4 - MAX. PRESSURE LIMITATION
- 5 - O-RING 9.25X1.78 (PORT X AND Y)
- 6 - FIXING SCREW HOLE
- 7 - BLOCKED UP IN VALVE TYPE DBET/DBEMT  
FIXED WITH THROTTLE HOLE IN VALVE TYPE DBEC/DBEMC
- 8 - PILOT OIL DRAIN PORT, OPTIONAL

