

Ordering Code: **EP-20M-X-Y-Z-05**

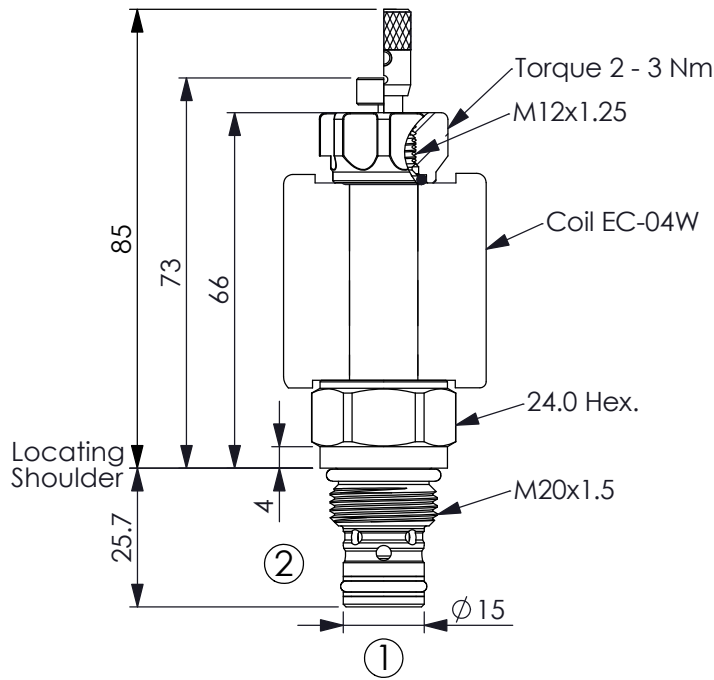

UNIT:mm

Illustrations / detail are for reference only. Data subject to change.

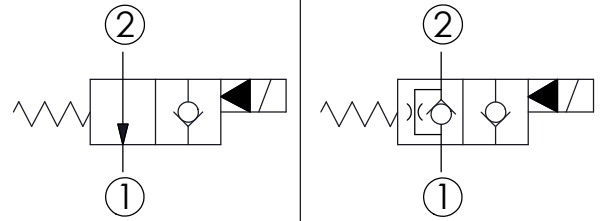

TECHNICAL DATA

Max.Operating pressure:	350	bar
Rated flow:	40	l/min
Cavity-Tooling:	20M-2	
Installation torque:	39 - 51	Nm
Weight:	0.13 (Z=N)	0.14 (Z=P,T) kg

Internal Leakage Approximately:
0.15 cc/minute
(3 drops/minute) max. at 350 bar

Hydraulic Fluid Viscosity · Cleanliness · Temperature Level:
Please refer WINNER technical information.
(T.101.101.E HYDRAULIC FLUID (A) VISCOSITY)
(T.101.102.E HYDRAULIC FLUID (B) CLEANLINESS)
(T.101.103.E HYDRAULIC FLUID (C) TEMPERATURE)

Minimum Voltage Required:
90 % of nominal

Coils must be ordered separately

Mounting Position: unrestricted

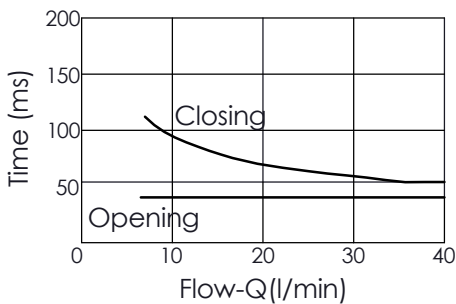
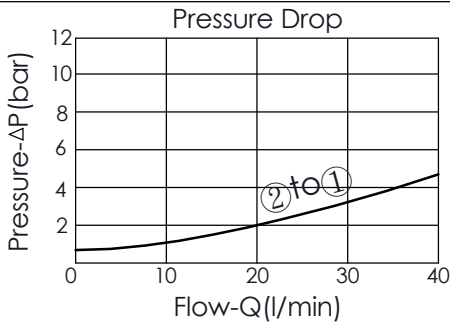

The performance curve or data is only for reference, as customers' using condition, pressure, flow, hydraulic fluid viscosity, cleanliness, temperature and so on are different, the curve or data will be different.

Y	OPERATION
02	Normally-Open No Reverse Flow De-energized

In de-energized condition, this valve is allowed flow from port ② to port ① but it's difficult to pass that flow from port ① to port ②.
This valve is similar to check valve when energized. Allow free flow from port ① to port ② and block flow from port ② to port ①.
If you need bi-directional flow, please refer Y=06.

X	STRUCTURE
2A	2 Ports · 20 Watt. Coil ∅ 12.7 mm tube

Z	OPTIONS
N	Non-adjustable
P	Push Style Manual Override
T	Push and Twist Style Manual Override