



# M+S HYDRAULIC

## HYDRAULIC MOTORS

MM  
MP  
MR  
MH



ТОВ "Промислова Гідравліка": <https://promhydraulic.com.ua/ua/>

Телефонуйте: +380 (95) 670-15-32, +380 (98) 533-91-67, +380 (96) 244-48-42

# SPOOL VALVE HYDRAULIC MOTORS

## CONTENTS

	Page
● Hydraulic Motors Series MM .....	4
● Hydraulic Motors Series MP .....	13
● Hydraulic Motors Series MR .....	32
● Hydraulic Motors Series MR...T (tacho).....	43
● Hydraulic Motors Series SP .....	44
● Hydraulic Motors Series SR .....	50
● Hydraulic Motors Series MRNA .....	59
● Hydraulic Motors Series MRFL .....	60
● Hydraulic Motors with Dual Shaft Series MRB .....	62
● Hydraulic Motors Series PL .....	65
● Hydraulic Motors Series RL .....	70
● Hydraulic Motors Series PK .....	75
● Hydraulic Motors Series RK .....	79
● Hydraulic Motors Series RW .....	83
● Hydraulic Motors Series MH .....	93
● Hydraulic Motors Series HW .....	102
● Motor Special Features .....	119
● Motors with Speed Sensor .....	120
● Application Calculations .....	122

"M+S HYDRAULIC" can accept no responsibility for possible errors in catalogues, brochures and other printed material.

"M+S HYDRAULIC" reserves the right to alter its products without notice. This also applies to products already on order provided that such alterations can be made without subsequential changes being necessary in specifications already agreed.

# SPOOL VALVE HYDRAULIC MOTORS

---

## GENERAL INFORMATION:

---

Orbit motors convert hydraulic energy (pressure, oil flow) into mechanical energy (torque, speed). Hydraulic orbit motors operate on the principle of an internal gear (rotor) rotating within a fixed external gear (stator). The internal gear transmits the torque generated by the application of pressure from hydraulic oil fed into motor which is then delivered via the motor's output shaft. Orbit motors have high starting torque and constant output torque at wide speed range.

### DISTRIBUTOR VALVE

MM, MP, MR, SP, SR, MH, PL, RL, PK, RK, RW, HW series motors have spool valve: the distributor valve has been integrated with the output shaft. The cardan shaft rotates distributor valve and transfers mechanical energy from gerotor set to output shaft. The valve has hydrodynamic bearings and has infinite life when load ratings are not exceeded.

### GEARWHEEL SET

There are two forms of gearwheel set:

- Gerotor set has plain teeth. These type of motors are suitable for long operating periods at moderate pressures or short operating periods at high pressures. MM, MP, SP, PL and PK series motors have gerotor set.

- Roll-gerotor set has teeth fitted with rollers. The rollers reduce local stress and the tangential reaction forces on the rotor reducing friction to a minimum. This gives long operating life and better efficiency even at continuous high pressures. Roll-gerotor sets are recommended for operation with thin oil and for applications with continually reversing loads. MR, SR, RL, RK, MH, RW and HW series motors have roll-gerotor set.

## FEATURES:

---

**Standard Motor** The standard motor mounting flange is located as close to the output shaft as possible. This type of mounting supports the motor close to the shaft load. This mounting flange is also compatible with many standard gear boxes.

**Wheel Motor** W mounting flange makes the motors possible to fit a wheel hub or a winch drum so that the radial load acts closer to motor bearings. This gives the best utilization of the bearing capacity and is a very compact solution.

**Needle Bearing** MPN and MRN have an output shaft supported in needle bearing. These types motors are suitable for operating conditions such as frequent start and stops, vibration on the shaft, high static and dynamic radial loads in short operating terms.

**Low Leakage** LL Series hydraulic motors are designed to operate at the whole standard range of working conditions (pressure drop and frequency of rotation), but with considerable decreased volumetric losses in the drain ports. This motors are suitable for hydraulic systems with series-connected motors with demands for low leakage.

**Low Speed Valve** LSV feature optimizes the motor for low-speed performance. Motors with this valving provide very low speed while maintaining high torque. They are designed to run continuously at low speed (up to  $200 \text{ min}^{-1}$ ) at normal pressure drop and reduced flow. Optimal run is guaranteed at frequency of rotation from 20 to  $50 \text{ min}^{-1}$ . Motors with this valving have an increased starting pressure and are not recommended for using at pressure drop less than 40 bar.

**Free Running** FR motors are with increased clearance at all friction parts, allowing the shaft to rotate more freely with less mechanical drag. The increased clearance also improves lubrication of the wear surfaces of gear set and friction parts. Additional advantages of "FR" version are prolonging of the life of the hydraulic motors at high speeds, as well as the possibility to use them in systems with wide variation of the loading. FR Series motors are designed to operate with high speed /over than  $300 \text{ min}^{-1}$ / and low pressure drop. Volumetric efficiency may be reduced slightly.

**High Pressure Shaft Seal** The high pressure shaft seals allow the motors to withstand high case pressures at high speeds without external drain line.

**Motors with Speed Sensor** Motors are available with integrated inductive speed sensor. The output signal is a standardized voltage signal that can be used to control the speed of a motor. The torque and the radial load of the motor are not affected by the installation of speed sensor.

# HYDRAULIC MOTORS MM



## CONTENTS

Specification data .....	5
Function diagrams .....	6÷8
Dimensions and mounting ...	9÷10
Shaft extensions .....	11
Permissible shaft loads .....	11
Order code .....	12

## APPLICATION

- » Conveyors
- » Textile machines
- » Mining machinery
- » Machine tools
- » Ventilators
- » Construction plant equipment and access platforms etc.

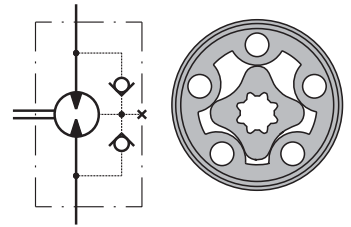

### Pressure Settings at Flow Q= .53 GPM [2 lpm], 150 SUS [32 mm<sup>2</sup>/s], 50°C [122°F]

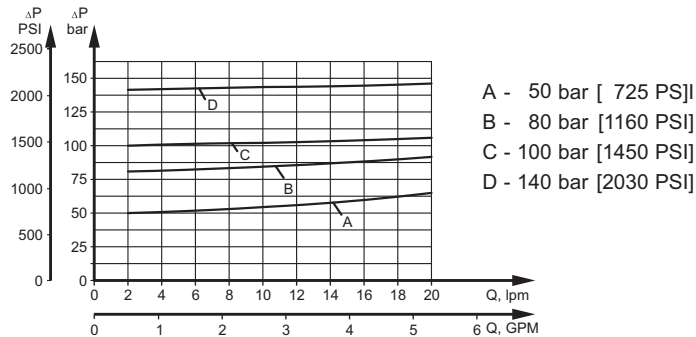

## OPTIONS

- » Model - Spool valve, gerotor
- » With or without flange
- » Side and rear ports
- » Series with pressure valve(s)
- » Shafts - straight and splined
- » Metric and BSPP ports
- » Speed sensing;
- » Other special features

### MMP Series with Integrated Internal Crossover Relief Valve A → B, Δp=100 or 50 bar [1450 or 725 PSI]

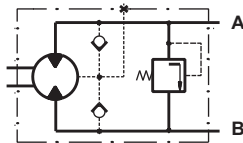

### MMP Series with Integrated Internal Crossover Relief Valve B → A, Δp=100 or 50 bar [1450 or 725 PSI]

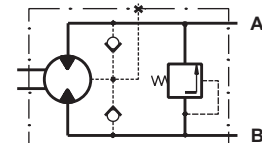

### Pressure Losses

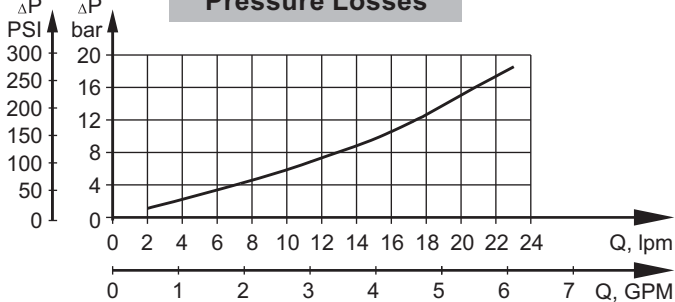

### MMD Series with Integrated Internal Crossover Relief Valves A ↔ B, Δp=100 or 50 bar [1450 or 725 PSI]

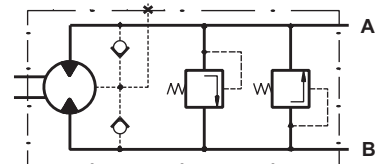

## GENERAL

Max. Displacement,	cm <sup>3</sup> /rev [in <sup>3</sup> /rev]	50 [3.05]
Max. Speed,	[RPM]	2440
Max. Torque,	daNm [lb-in]	cont.: 4,5 [398]    int.: 5,8 [513]
Max. Output,	kW [HP]	3,2 [4.3]
Max. Pressure Drop,	bar [PSI]	cont.: 105 [1500]    int.: 140 [2030]
Max. Oil Flow,	lpm [GPM]	25 [6.6]
Min. Speed,	[RPM]	20
Pressure fluid		Mineral based- HLP(DIN 51524) or HM(ISO 6743/4)
Temperature range,	°C [°F]	-40÷140 [-40÷284]
Optimal Viscosity range,	mm <sup>2</sup> /s [SUS]	20÷75 [98÷347]
Filtration		ISO code 20/16 (Min. recommended fluid filtration of 25 microns)

## SPECIFICATION DATA

Type		MM 8	MM 12.5	MM 20	MM 32	MM 40	MM 50
<b>Displacement, cm<sup>3</sup>/rev [in<sup>3</sup>/rev]</b>		8,2 [50]	12,5 [77]	19,9 [1.22]	31,6 [1.93]	39,8 [2.43]	50 [3.08]
<b>Max. Speed, [RPM]</b>	Cont.	1950	1550	1000	630	500	400
	Int.*	2450	1940	1250	800	630	500
<b>Max. Torque daNm [lb-in]</b>	Cont.	1,1 [95]	1,6 [140]	2,5 [220]	4,0 [350]	4,5 [400]	4,6 [410]
	Int.*	1,5 [135]	2,3 [200]	3,5 [310]	5,7 [500]	7,0 [620]	8,8 [780]
	Peak**	2,1 [187]	3,3 [293]	5,1 [453]	6,4 [568]	8,2 [725]	10,0 [885]
<b>Max. Output kW [HP]</b>	Cont.	1,8 [2.4]	2,4 [3.2]	2,4 [3.2]	2,4 [3.2]	2,2 [3.0]	1,8 [2.4]
	Int.*	2,6 [3.5]	3,2 [4.3]	3,2 [4.3]	3,2 [4.3]	3,2 [4.3]	3,2 [4.3]
<b>Max. Pressure Drop bar [PSI]</b>	Cont.	100 [1450]	100 [1450]	100 [1450]	100 [1450]	90 [1310]	70 [1020]
	Int.*	140 [2030]	140 [2030]	140 [2030]	140 [2030]	140 [2030]	140 [2030]
	Peak**	200 [2900]	200 [2900]	200 [2900]	160 [2320]	160 [2320]	160 [2320]
<b>Max. Oil Flow lpm [GPM]</b>	Cont.	16 [4.2]	20 [5.3]	20 [5.3]	20 [5.3]	20 [5.3]	20 [5.3]
	Int.*	20 [5.3]	25 [6.6]	25 [6.6]	25 [6.6]	25 [6.6]	25 [6.6]
<b>Max. Inlet Pressure bar [PSI]</b>	Cont.	140 [2030]	140 [2030]	140 [2030]	140 [2030]	140 [2030]	140 [2030]
	Int.*	175 [2540]	175 [2540]	175 [2540]	175 [2540]	175 [2540]	175 [2540]
	Peak**	225 [3260]	225 [3260]	225 [3260]	225 [3260]	225 [3260]	225 [3260]
<b>Max. Return Pressure without Drain Line or Max. Pressure in Drain Line, bar [PSI]</b>	Cont. 0-100 RPM	140 [2030]	140 [2030]	140 [2030]	140 [2030]	140 [2030]	140 [2030]
	Cont. 100-400 RPM	105 [1500]	105 [1500]	105 [1500]	105 [1500]	105 [1500]	105 [1500]
	Cont. 400-800 RPM	50 [725]	50 [725]	50 [725]	50 [725]	50 [725]	50 [725]
	Cont. >800 RPM	20 [290]	20 [290]	20 [290]	-	-	-
Int.* 0-max. RPM	140 [2030]	140 [2030]	140 [2030]	140 [2030]	140 [2030]	140 [2030]	
<b>Max. Return Pressure with Drain Line bar [PSI]</b>	Cont.	140 [2030]	140 [2030]	140 [2030]	140 [2030]	140 [2030]	140 [2030]
	Int.*	175 [2540]	175 [2540]	175 [2540]	175 [2540]	175 [2540]	175 [2540]
	Peak**	225 [3260]	225 [3260]	225 [3260]	225 [3260]	225 [3260]	225 [3260]
<b>Max. Starting Pressure with Unloaded Shaft, bar [PSI]</b>		4 [60]	4 [60]	4 [60]	4 [60]	4 [60]	4 [60]
<b>Min. Starting Torque daNm [lb-in]</b>	At max. press. drop Cont.	0,7 [60]	1,2 [105]	2,1 [185]	3,4 [300]	3,8 [335]	4,1 [365]
	At max. press. drop Int.*	1,0 [90]	1,7 [150]	2,9 [255]	4,8 [425]	6,2 [550]	7,9 [700]
<b>Min. Speed***, [RPM]</b>		50	40	30	30	25	20
<b>Weight, kg [lb] For "F" flange: + 0,200 [.441]</b>	MM	1,9 [4.2]	2,0 [4.41]	2,1 [4.63]	2,2 [4.85]	2,3 [5.07]	2,5 [5.51]
	MMF(S)	2,0 [4.41]	2,1 [4.63]	2,2 [4.85]	2,3 [5.07]	2,4 [5.29]	2,6 [5.73]
	MMP	2,2 [4.85]	2,3 [5.07]	2,4 [5.29]	2,5 [5.51]	2,6 [5.73]	2,8 [6.17]
	MMD	2,6 [5.73]	2,7 [5.95]	2,8 [6.17]	2,9 [6.39]	3,0 [6.61]	3,2 [7.05]

\* Intermittent operation: the permissible values may occur for max. 10% of every minute.

\*\* Peak load: the permissible values may occur for max. 1% of every minute.

\*\*\* For speeds lower than given, consult factory or your regional manager.

- Intermittent speed and intermittent pressure must not occur simultaneously.
- Recommended filtration is per ISO cleanliness code 20/16. A nominal filtration of 25 micron or better.
- Recommend using a premium quality, anti-wear type mineral based hydraulic oil HLP(DIN51524) or HM (ISO 6743/4).  
If using synthetic fluids consult the factory for alternative seal materials.
- Recommended minimum oil viscosity 13 mm<sup>2</sup>/s [70 SUS] at 50°C [122°F].
- Recommended maximum system operating temperature is 82°C [180°F].
- To assure optimum motor life fill with fluid prior to loading and run at moderate load and speed for 10-15 minutes.

**FUNCTION DIAGRAMS**

**MM 8**

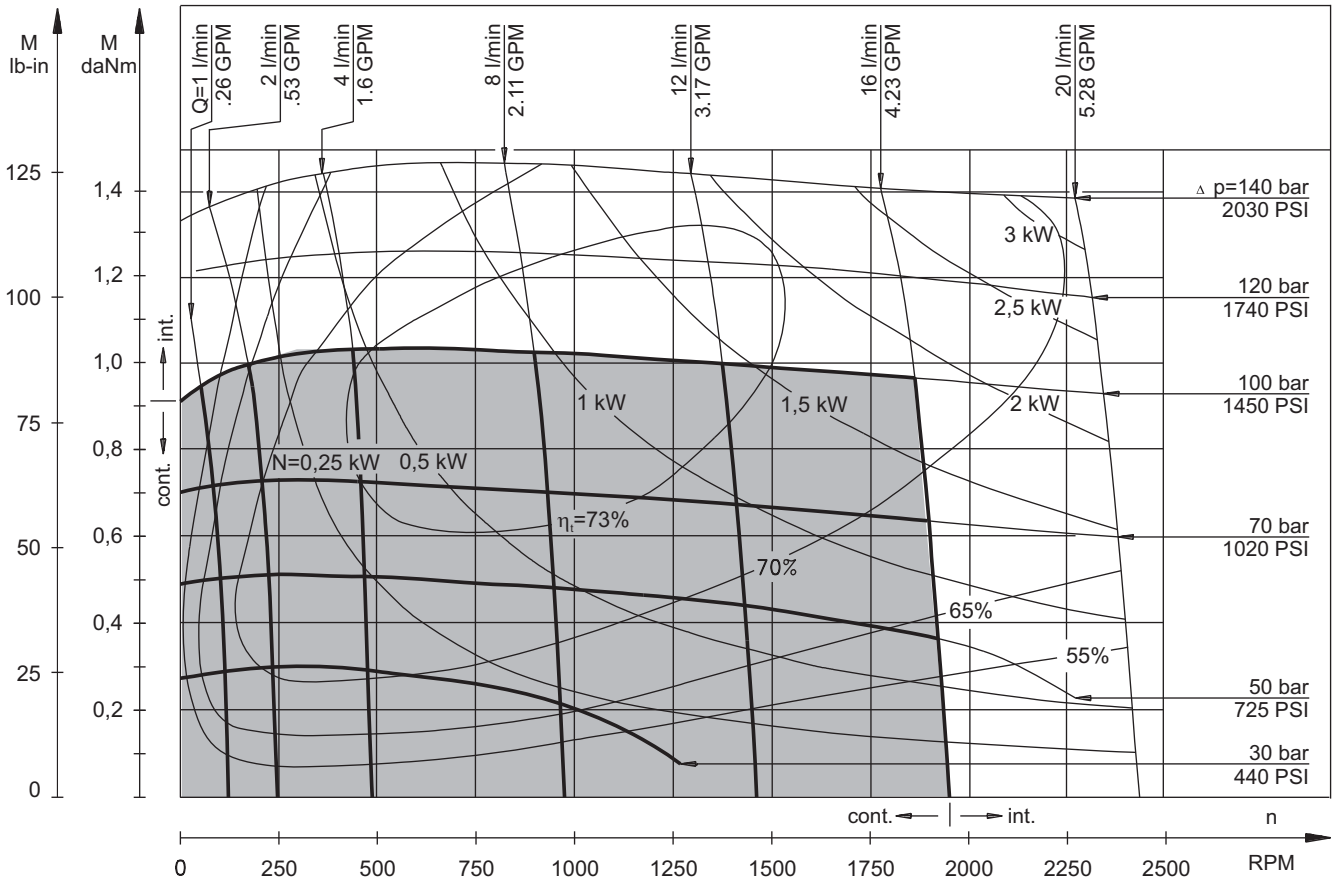

**MM 12,5**

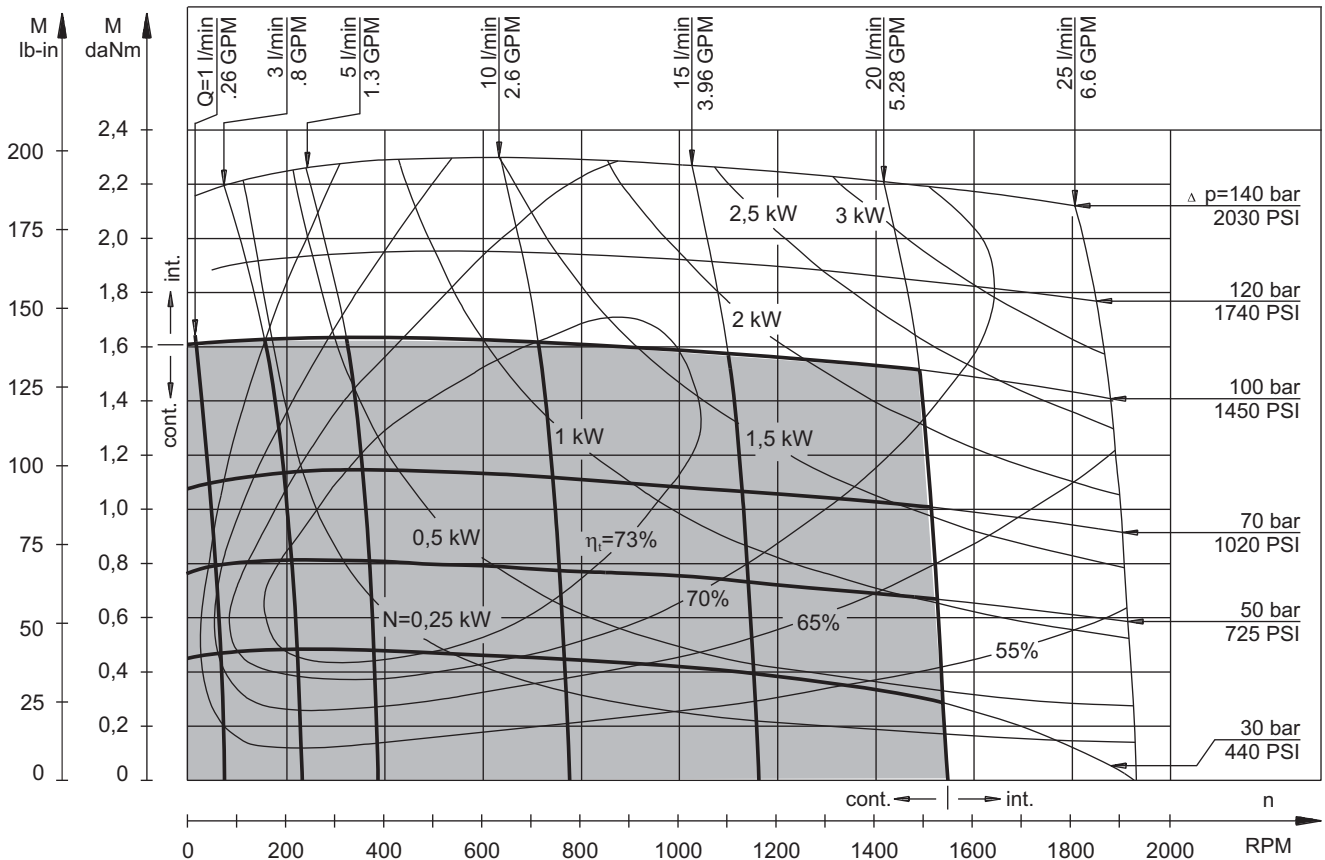

The function diagrams data is for average performance of randomly selected motors at back pressure 5÷10 bar [72.5÷145 PSI] and oil with viscosity of 32 mm<sup>2</sup>/s [150 SUS] at 50°C [122°F].

**FUNCTION DIAGRAMS**

**MM 20**

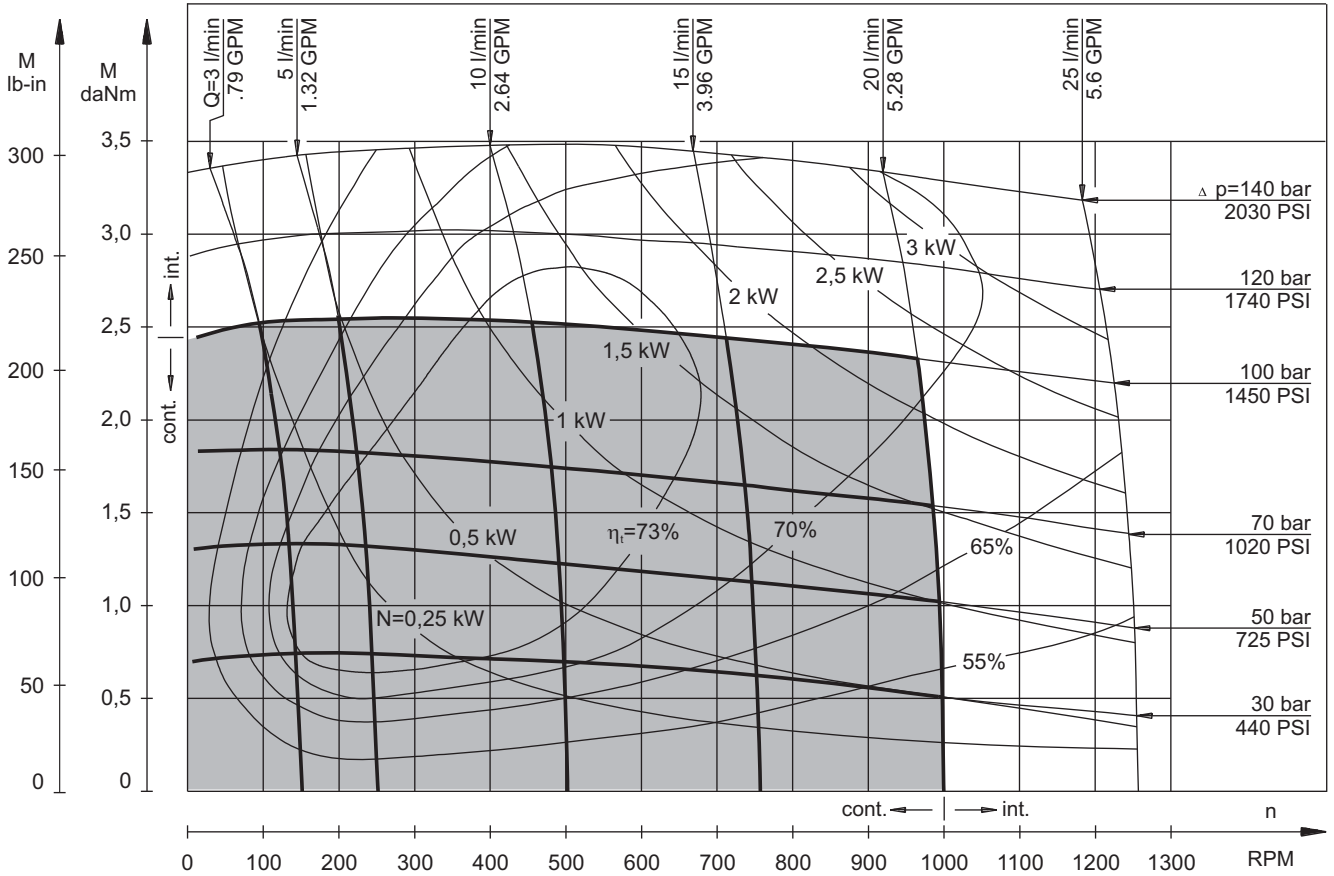

**MM 32**

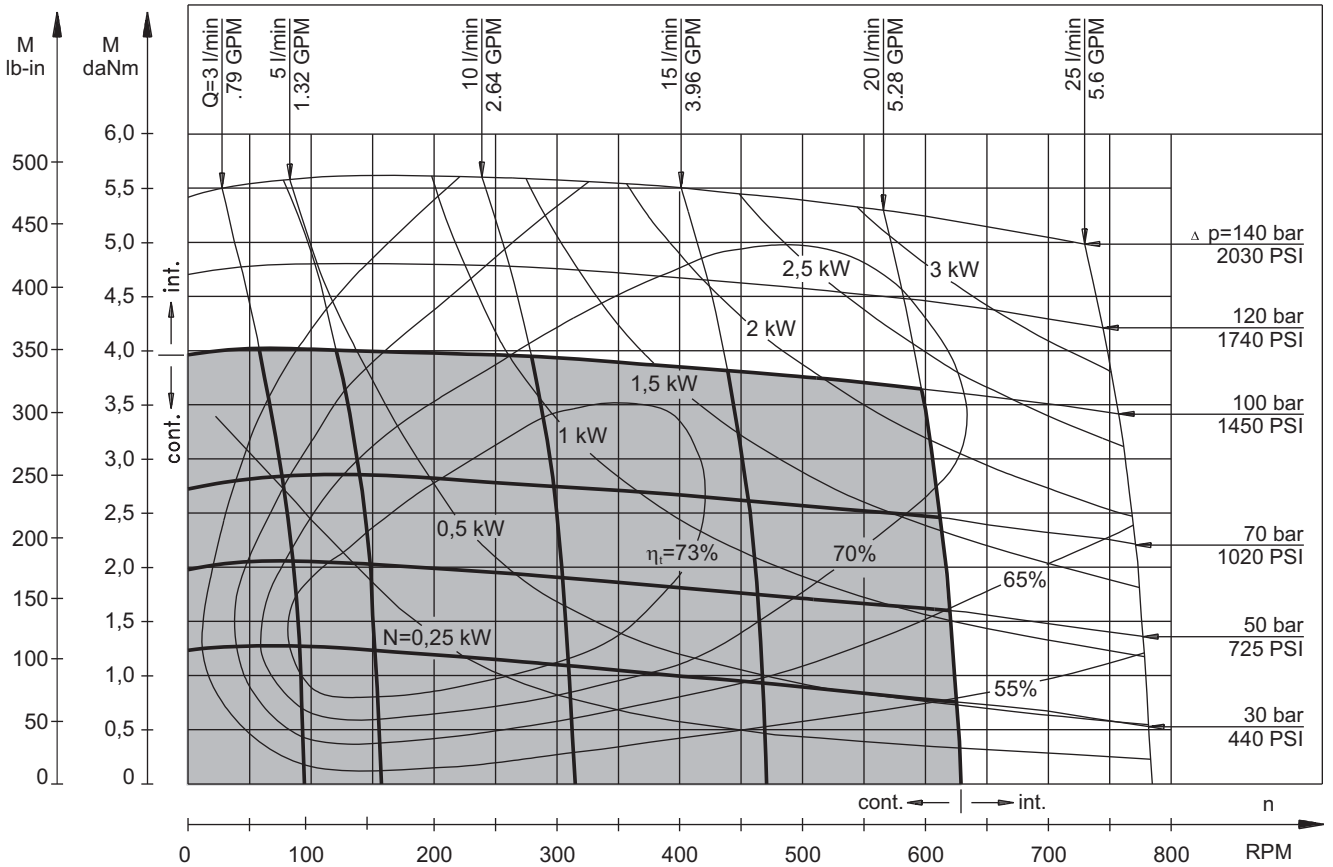

The function diagrams data is for average performance of randomly selected motors at back pressure 5÷10 bar [72.5÷145 PSI] and oil with viscosity of 32 mm<sup>2</sup>/s [150 SUS] at 50°C [122°F].

**FUNCTION DIAGRAMS**

**MM 40**

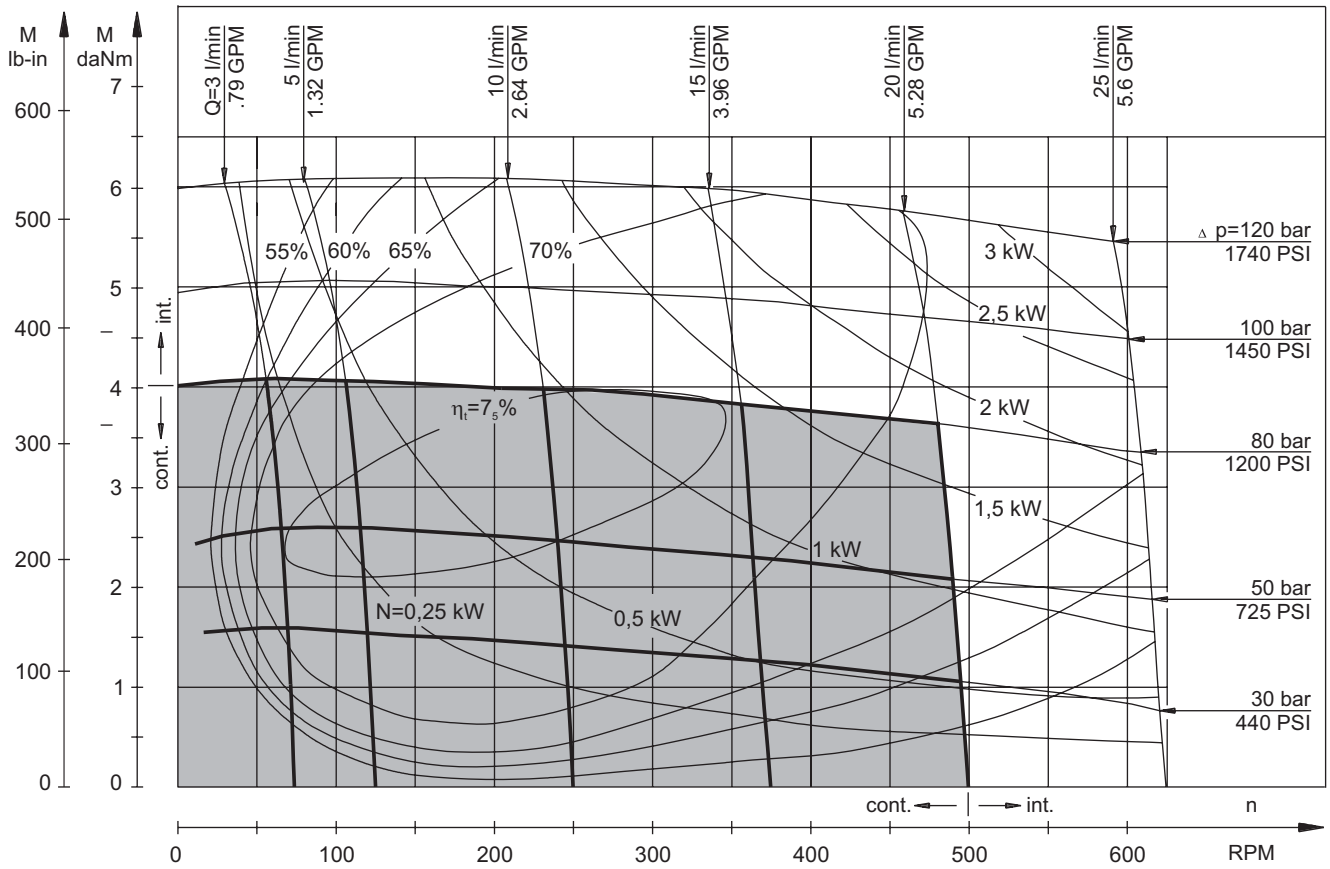

**MM 50**

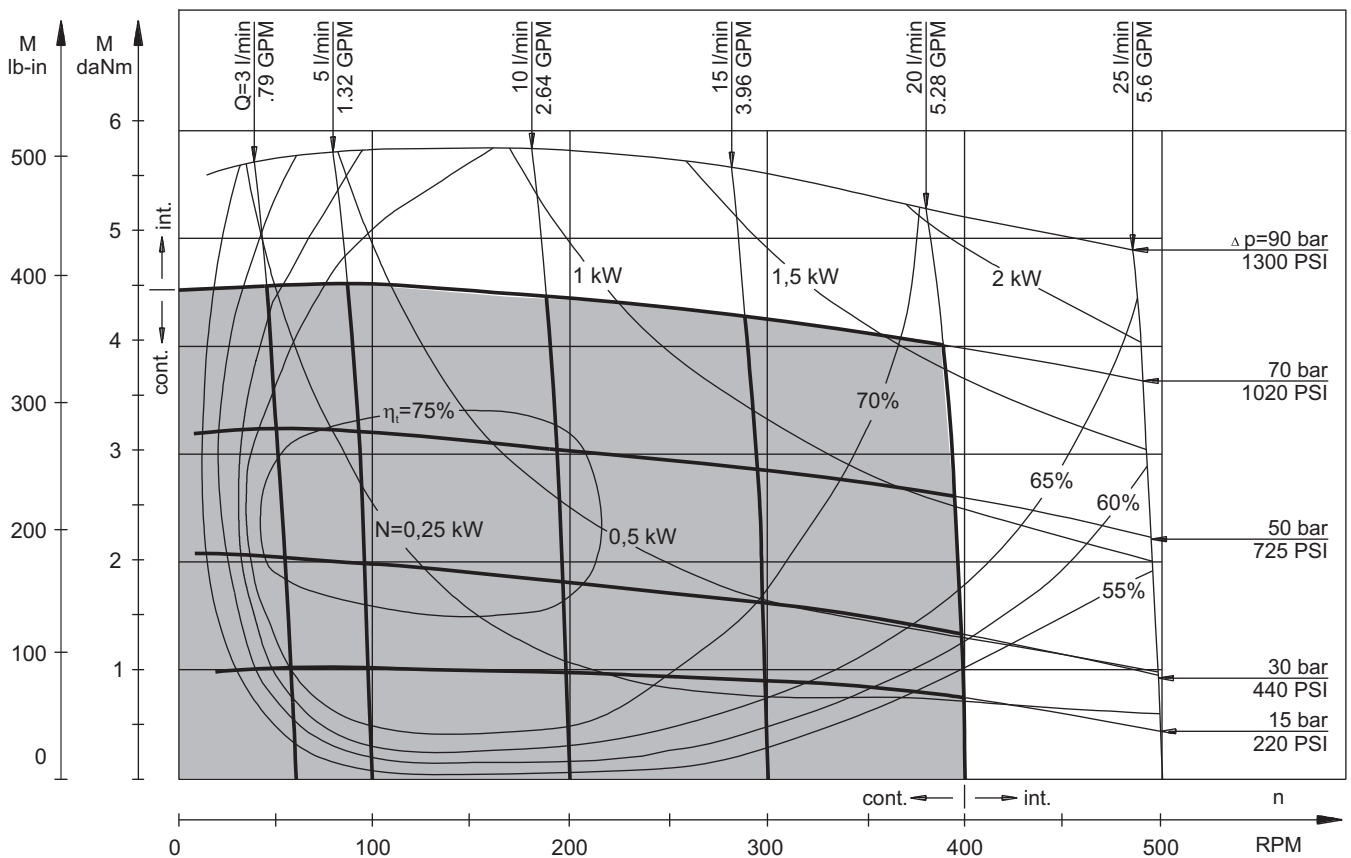

The function diagrams data is for average performance of randomly selected motors at back pressure 5÷10 bar [72.5÷145 PSI] and oil with viscosity of 32 mm<sup>2</sup>/s [150 SUS] at 50°C [122°F].

**DIMENSIONS AND MOUNTING DATA**  
**MM, MMS, MMP, MMD**

**Three Bolts Mount**

SH Shaft C Shaft CK Shaft

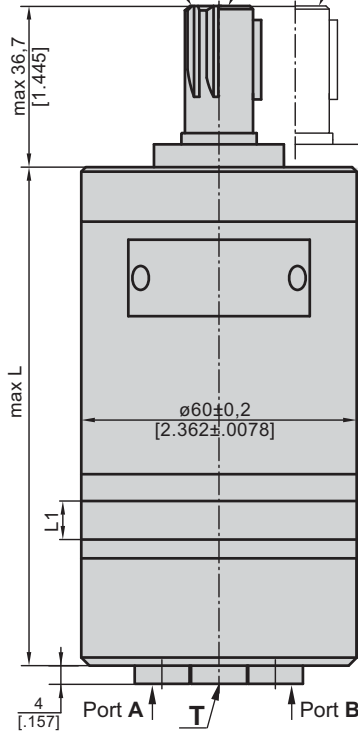

Shaft Dim.  
See Page 11

Flange Dim.  
See Page 10

Port Dim.  
See Page 10

**F Oval Mount (2 Holes)**

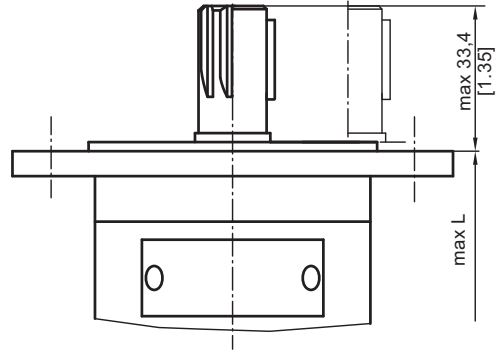

**Standard Rotation**

Viewed from Shaft End

Port A Pressurized - **CW**

Port B Pressurized - **CCW**

**Reverse Rotation**

Viewed from Shaft End

Port A Pressurized - **CCW**

Port B Pressurized - **CW**

Rear Ports

**S** Side Ports

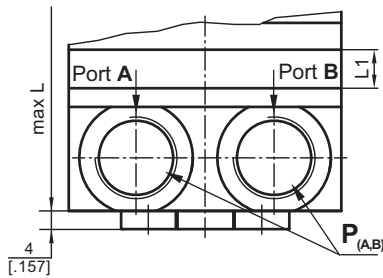

**P** Side Ports

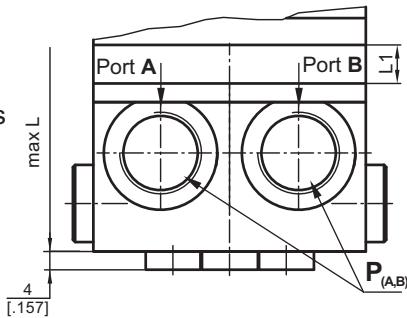

**D** Side Ports

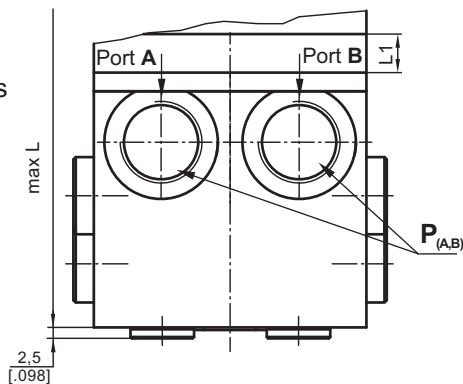

$P_{(A,B)}$ : 2xG3/8 or 2xM18x1,5 - 12 mm [.47 in] depth

$T$ : G1/8 or M10x1 - 10 mm [.39 in] depth

Type	L, mm [in.]	Type	L, mm [in.]	L <sub>1</sub> , mm [in.]
MM 8	104 [4.094]	MMS 8	105 [4.134]	3,5 [.138]
MM 12,5	106 [4.173]	MMS 12,5	107 [4.213]	5,5 [.217]
MM 20	109 [4.291]	MMS 20	110 [4.331]	8,5 [.335]
MM 32	114 [4.488]	MMS 32	115 [4.528]	13,5 [.531]
MM 40	117,5 [4.626]	MMS 40	118,5 [4.665]	17 [.669]
MM 50	121,5 [4.783]	MMS 50	122,5 [4.823]	21 [.827]

Type	L, mm [in.]	Type	L, mm [in.]	L <sub>1</sub> , mm [in.]
MMP 8	115 [4.528]	MMD 8	134 [5.276]	3,5 [.138]
MMP 12,5	117 [4.606]	MMD 12,5	136 [5.354]	5,5 [.217]
MMP 20	120 [4.724]	MMD 20	139 [5.472]	8,5 [.335]
MMP 32	125 [4.921]	MMD 32	144 [5.669]	13,5 [.531]
MMP 40	128,5 [5.039]	MMD 40	147,5 [5.807]	17 [.669]
MMP 50	132,5 [5.217]	MMD 50	151,5 [5.965]	21 [.827]

For "F" Flange +3,5 mm



mm [in]

**MOUNTING**

**Three Bolts Mount**

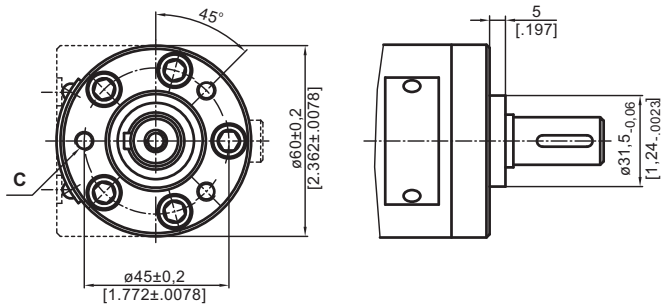

**F Oval Mount (2 Holes)**

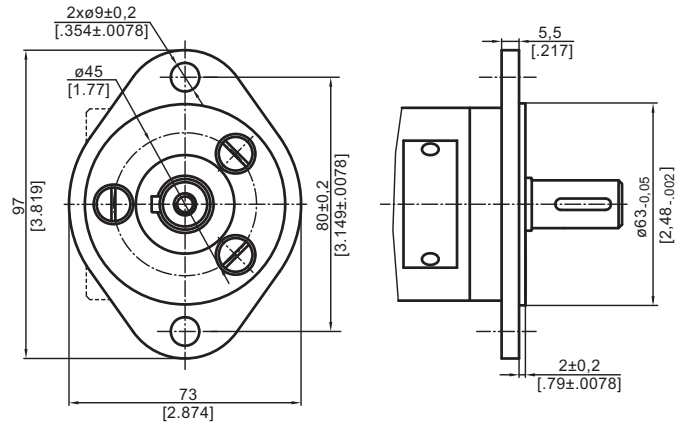

**PORTS**

**Rear Ports**

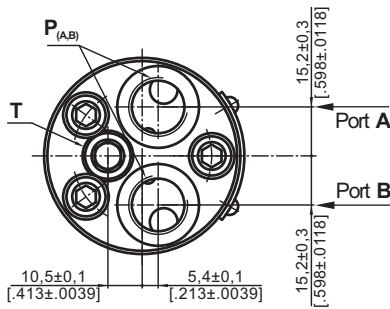

**S Side Ports**

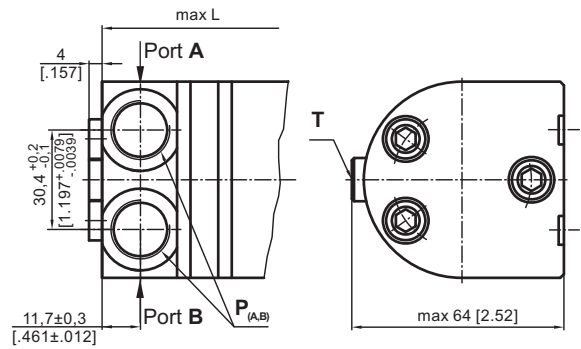

**P Side Ports with Single Crossover Relief Valve**

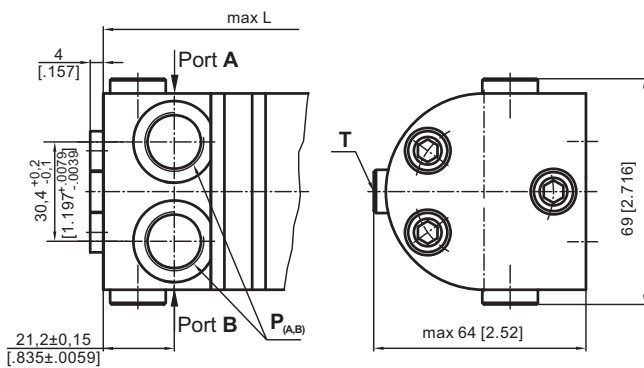

**D Side Ports with Dual Crossover Relief Valve**

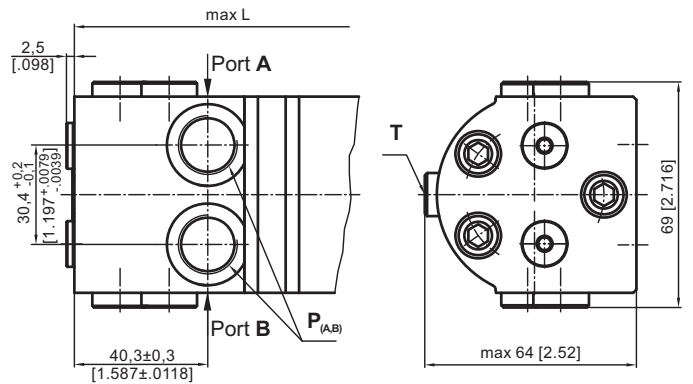

**Standard Rotation**  
Viewed from Shaft End  
Port A Pressurized - CW  
Port B Pressurized - CCW

**Reverse Rotation**  
Viewed from Shaft End  
Port A Pressurized - CCW  
Port B Pressurized - CW

**C** : 3xM6 - 12 mm [.47 in] depth  
**P<sub>(A,B)</sub>** : 2xG3/8 or 2xM18x1,5 - 12 mm [.47 in] depth  
**T** : G1/8 or M10x1 - 10 mm [.39 in] depth

**SHAFT EXTENSIONS**

**C** -  $\varnothing 16$  straight, Parallel key 5x5x16 DIN 6885  
Max. Torque 3,9 daNm [345 lb-in]

**CK** -  $\varnothing 14$  straight, Parallel key 5x5x16 DIN 6885  
Max. Torque 3 daNm [265 lb-in]

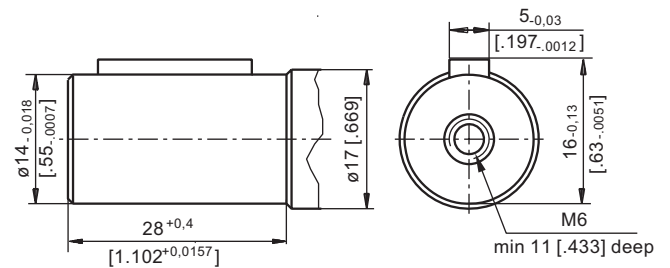
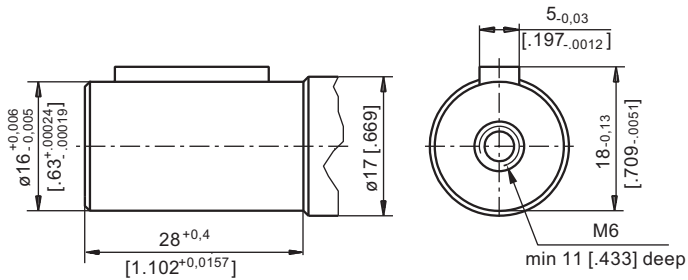

**SH** -  $\varnothing 16,5$  Splined, B17x14 DIN 5482  
Max. Torque 4,4 daNm [390 lb-in]

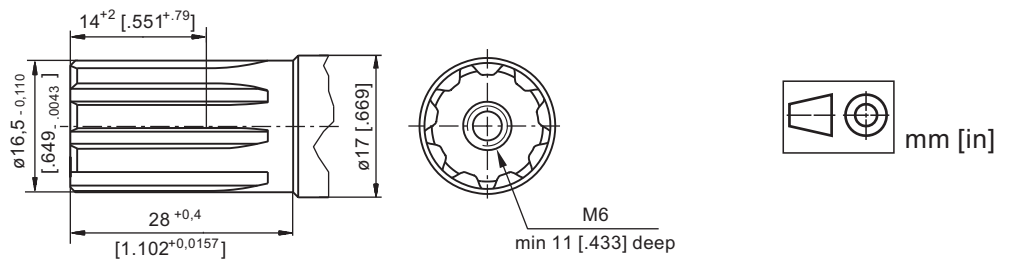

**PERMISSIBLE SHAFT LOAD**

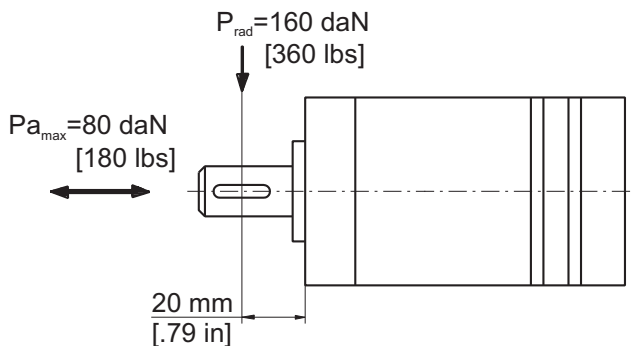

The permissible radial shaft load [Prad] is calculated from the distance [L] between the point of load application and the mounting surface:

$$P_{rad} = \frac{600}{n} \times \frac{13040}{61,5+L}, \text{ [daN]}$$

[L in mm; L ≤ 80 mm]

$$P_{rad} = \frac{600}{n} \times \frac{1155}{2,42+L}, \text{ [lbs]}$$

[L in inch; L ≤ 3.15 in]

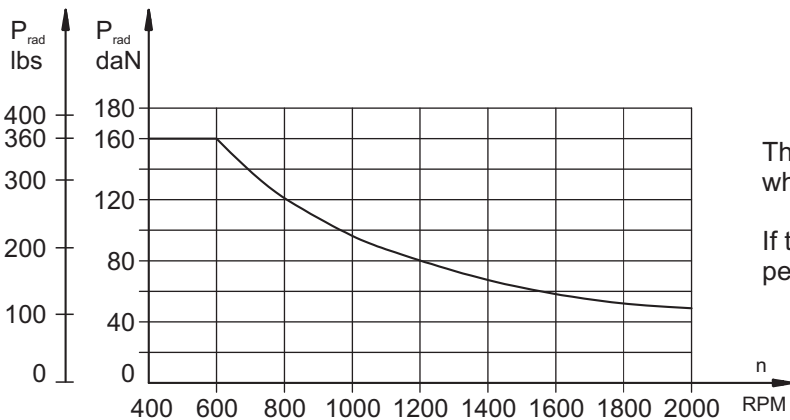

The drawing shows the permissible radial load when L=20 mm [.79 in].

If the calculated shaft load exceeds the permissible, a flexible coupling must be used.

**ORDER CODE**

	1	2	3	4	5	6	7	8	9	10
<b>M M</b>										

**Pos.1 - Adjustment Option**

- omit - without valve
- P\*** - Side ports with single crossover relief valve
- D\*** - Side ports with dual crossover relief valve

**Pos.2 - Mounting Flange**

- omit - Three bolts mount
- F** - Oval mount, two holes

**Pos.3 - Port type (not valid for P and D version)**

- omit - Rear ports
- S** - Side ports

**Pos.4 - Displacement code**

- 8** - 8,2 cm<sup>3</sup>/rev [ .5 in<sup>3</sup>/rev]
- 12.5** - 12,9 cm<sup>3</sup>/rev [ .79 in<sup>3</sup>/rev]
- 20** - 20,0 cm<sup>3</sup>/rev [1.22 in<sup>3</sup>/rev]
- 32** - 31,8 cm<sup>3</sup>/rev [1.93 in<sup>3</sup>/rev]
- 40** - 40,0 cm<sup>3</sup>/rev [2.44 in<sup>3</sup>/rev]
- 50** - 50,0 cm<sup>3</sup>/rev [3.05 in<sup>3</sup>/rev]

**Pos. 5 - Shaft Extensions\***

- C** - ø16 straight, Parallel key A5x5x16 DIN6885
- VC** - ø16 straight, Parallel key A5x5x16 DIN6885 with corrosion resistant bushing
- CK** - ø14 straight, Parallel key 5x5x16 DIN6885
- SH** - ø16,5 splined, B17x14 DIN 5482

**Pos. 6 - Ports**

- omit - BSPP (ISO 228)
- M** - Metric (ISO 262)

**Pos. 7 - Line to control\*\* (see page 4)**

- /L** - B → A (left running)
- /R** - A → B (right running)

**Pos. 8 - Valve Rated Pressure\*\*\***

- /50** - Δp=50 bar [725 PSI]
- /80** - Δp=80 bar [1160 PSI]
- /100** - Δp=100 bar [1450 PSI]
- /140** - Δp=140 bar [2030 PSI]

**Pos. 9 - Special Features (see page 119)**

**Pos.10 - Design Series**

- omit - Factory specified

**NOTES:**

- \* The permissible output torque for shafts must not be exceeded!
- \*\* For **P** option useful only.
- \*\*\* For **P** and **D** option useful only.

**!** **MMP** and **MMD** are available with new crossover relief valves with improved characteristics. The new valves allow easier pressure setting in a wider range: from 50 bar [725 PSI] to 140 bar [2030 PSI]. For more information about MMP and MMD - series 2 please contact with "M+S Hydraulic".

The Valve pressure setting must be at flow rate of 2 lpm [.53 GPM].

The hydraulic motors are mangan - phosphatized as standard.

**F - FLANGE (2 Holes)**

Order No for Flange:48443 014 00

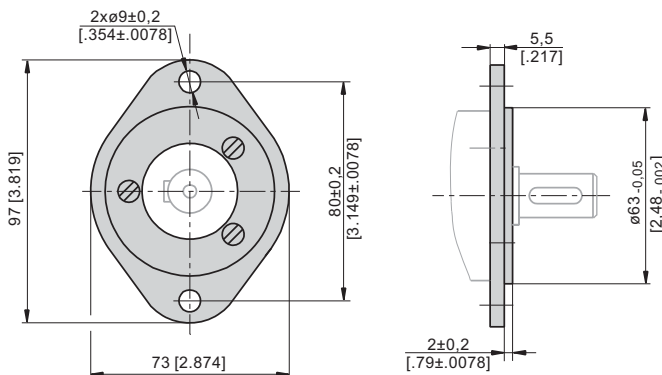

**F** Flange is mounted to the motor with 3 screws - M6x14. Tightening Torque: 5-6 Nm [44-53 lb-in].

# HYDRAULIC MOTORS MP



## APPLICATION

- » Conveyors
- » Feeding mechanism of robots and manipulators
- » Metal working machines
- » Textile machines
- » Agricultural machines
- » Food industries
- » Grass cutting machinery etc.

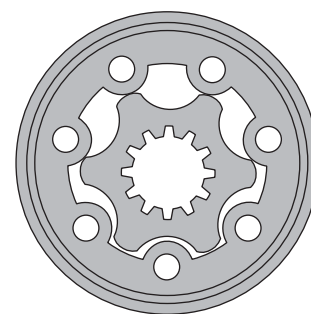

## CONTENTS

Specification data .....14÷17  
 Function diagrams .....18÷24  
 Dimensions and mounting ..... 25÷26  
 Wheel motor ..... 27  
 Shaft extensions ..... 28  
 Permissible shaft loads ..... 29  
 Permissible shaft Seal Pressure ... 30  
 Order code ..... 31

## OPTIONS

- » Model - Spool valve, gerotor
- » Flange and wheel mount
- » Motor with needle bearing
- » Side and rear ports
- » Shafts - straight, splined and tapered
- » Shaft seal for high and low pressure
- » Metric and BSPP ports
- » Speed sensing
- » Other special features

## GENERAL

<b>Max. Displacement,</b> cm <sup>3</sup> /rev [in <sup>3</sup> /rev]	623,6 [38.05]
<b>Max. Speed,</b> [RPM]	1815
<b>Max. Torque,</b> daNm [lb-in]	cont.:50 [4415] int.: 64 [5565]
<b>Max. Output,</b> kW [HP]	12,8 [17.1]
<b>Max. Pressure Drop,</b> bar [PSI]	cont.:140 [2030] int.: [175 [2540]
<b>Max. Oil Flow,</b> lpm [GPM]	75 [19.8]
<b>Min. Speed,</b> [RPM]	10
<b>Pressure fluid</b>	Mineral based- HLP(DIN 51524) or HM(ISO 6743/4)
<b>Temperature range,</b> °C [°F]	-40÷140 [-40÷284]
<b>Optimal Viscosity range,</b> mm <sup>2</sup> /s [SUS]	20÷75 [98÷347]
<b>Filtration</b>	ISO code 20/16 (Min. recommended fluid filtration of 25 microns)

### Oil flow in drain line

Pressure drop bar [PSI]	Viscosity mm <sup>2</sup> /s [SUS]	Oil flow in drain line lpm [GPM]
100 [1450]	20 [98]	2,5 [.660]
	35 [164]	1,8 [.476]
140 [2030]	20 [98]	3,5 [.925]
	35 [164]	2,8 [.740]

### Pressure Losses

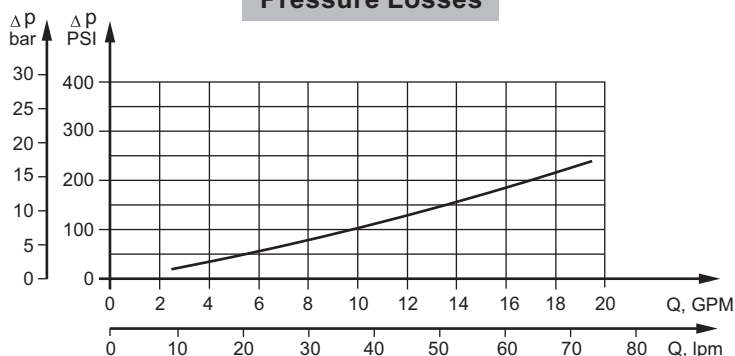

## SPECIFICATION DATA

Specification Data for MP... motors with **C, CO, SH, K** and **SA** shafts.  
( $\varnothing 28,56$  sealing diameter)

Type		MP 25	MP 32	MP 40	MP 50	MP 80	MP 100	MP 125
<b>Displacement, cm<sup>3</sup>/rev [in<sup>3</sup>/rev]</b>		28,4 [1.73]	34,5 [2,1]	40,5 [2.47]	49,5 [3.02]	79,2 [4.83]	99 [6.04]	123,8 [7.55]
<b>Max. Speed, [RPM]</b>	Cont.	1408	1450	1480	1210	755	605	486
	Int.*	1584	1594	1555	1515	945	755	605
<b>Max. Torque daNm [lb-in]</b>	Cont.	3,3 [290]	4,3 [380]	6,2 [550]	9,4 [835]	15,1 [1340]	19,3 [1710]	23,7 [2100]
	Int.*	4,7 [415]	6,1 [540]	8,2 [730]	11,9 [1050]	19,5 [1725]	23,7 [2100]	29,8 [2640]
	Peak**	6,7 [595]	8,6 [760]	10,7 [950]	14,3 [1285]	22,4 [1985]	27,5 [2435]	36,5 [3235]
<b>Max. Output kW [HP]</b>	Cont.	4,5 [6.0]	5,8 [7.8]	8,4 [11.5]	10,1 [13.5]	10,2 [13.7]	10,5 [14.1]	10,2 [13.7]
	Int.*	6,1 [8.2]	7,8 [10.5]	11,6 [15.5]	12,2 [16.1]	12,5 [16.8]	12,8 [17.1]	12 [16.1]
<b>Max. Pressure Drop bar [PSI]</b>	Cont.	100 [1450]	100 [1450]	120 [1750]	140 [2030]	140 [2030]	140 [2030]	140 [2030]
	Int.*	140 [2030]	140 [2030]	155 [2250]	175 [2540]	175 [2540]	175 [2540]	175 [2540]
	Peak**	225 [3260]	225 [3260]	225 [3260]	225 [3260]	225 [3260]	225 [3260]	225 [3260]
<b>Max. Oil Flow lpm [GPM]</b>	Cont.	40 [10.5]	50 [13.2]	60 [15.9]	60 [15.9]	60 [15.9]	60 [15.9]	60 [15.9]
	Int.*	45 [11.9]	55 [14.5]	70 [18.5]	75 [19.8]	75 [19.8]	75 [19.8]	75 [19.8]
<b>Max. Inlet Pressure bar [PSI]</b>	Cont.	175 [2540]	175 [2540]	175 [2540]	175 [2540]	175 [2540]	175 [2540]	175 [2540]
	Int.*	200 [2900]	200 [2900]	200 [2900]	200 [2900]	200 [2900]	200 [2900]	200 [2900]
	Peak**	225 [3260]	225 [3260]	225 [3260]	225 [3260]	225 [3260]	225 [3260]	225 [3260]
<b>Max. Return Pressure with Drain Line bar [PSI]</b>	Cont.	175 [2540]	175 [2540]	175 [2540]	175 [2540]	175 [2540]	175 [2540]	175 [2540]
	Int.*	200 [2900]	200 [2900]	200 [2900]	200 [2900]	200 [2900]	200 [2900]	200 [2900]
	Peak**	225 [3260]	225 [3260]	225 [3260]	225 [3260]	225 [3260]	225 [3260]	225 [3260]
<b>Max. Starting Pressure with Unloaded Shaft, bar [PSI]</b>		10 [145]	10 [145]	10 [145]	10 [145]	10 [145]	10 [145]	9 [131]
<b>Min. Starting Torque daNm [lb-in]</b>	At max.press. drop Cont.	3,0 [265]	4,0 [355]	5,4 [480]	7,8 [690]	13,2 [1170]	16,6 [1470]	20,7 [1830]
	At max.press. drop Int.*	4,2 [370]	5,6 [500]	6,8 [600]	10 [885]	16,8 [1490]	21 [1860]	26,6 [2360]
<b>Min. Speed***, [RPM]</b>		20	15	10	10	10	10	10
<b>Weight, kg [lb] For rear ports +0,450 [-.992]</b>	MP(F)(N)	5,6 [12.3]	5,6 [12.3]	5,7 [12.6]	5,8 [12.8]	5,9 [13.2]	6,1 [13.5]	6,2 [13.7]
	MPW(N)	5,3 [11.7]	5,3 [11.7]	5,4 [11.9]	5,5 [12.1]	5,6 [12.4]	5,8 [12.8]	5,9 [13]
	MPQ(N)	5,0 [11.1]	5,0 [11.1]	5,1 [11.2]	5,2 [11.5]	5,3 [11.7]	5,5 [12.1]	5,6 [12.3]

\* Intermittent operation: the permissible values may occur for max. 10% of every minute.

\*\* Peak load: the permissible values may occur for max. 1% of every minute.

\*\*\* For speeds lower than given, consult factory or your regional manager.

- Intermittent speed and intermittent pressure must not occur simultaneously.
- Recommended filtration is per ISO cleanliness code 20/16. A nominal filtration of 25 micron or better.
- Recommend using a premium quality, anti-wear type mineral based hydraulic oil HLP(DIN51524) or HM (ISO 6743/4).  
If using synthetic fluids consult the factory for alternative seal materials.
- Recommended minimum oil viscosity 13 mm<sup>2</sup>/s [70 SUS] at 50°C [122°F].
- Recommended maximum system operating temperature is 82°C [180°F].
- To assure optimum motor life fill with fluid prior to loading and run at moderate load and speed for 10-15 minutes.

## SPECIFICATION DATA (continued)

Specification Data for MP... motors with **C**, **CO**, **SH**, **K** and **SA** shafts.  
( $\varnothing 28,56$  sealing diameter)

Type		MP 160	MP 200	MP 250	MP 315	MP 400	MP 500	MP 630
<b>Displacement, cm<sup>3</sup>/rev [in<sup>3</sup>/rev]</b>		158,4 [9.66]	198 [12.1]	247,5 [15.1]	316,8 [19.3]	396 [24.16]	495 [30.2]	623,6 [38.05]
<b>Max. Speed, [RPM]</b>	Cont.	378	303	242	190	150	120	95
	Int.*	472	378	303	236	189	150	120
<b>Max. Torque daNm [lb-in]</b>	Cont.	31,3 [2770]	36,6 [3240]	38 [3360]	38 [3360]	36 [3190]	39 [3452]	44 [3895]
	Int.*	37,8 [3345]	45,6 [4035]	58,3 [5160]	56 [4960]	59 [5240]	57 [5045]	64 [5665]
	Peak**	43,8 [3880]	55 [4870]	68,5 [6060]	85 [7505]	85,4 [7560]	78 [6903]	82 [7257]
<b>Max. Output kW [HP]</b>	Cont.	10,1 [13.5]	10 [13.5]	7,5 [10]	5,8 [7.9]	4,6 [6.2]	3,5 [4.7]	3,3 [4.4]
	Int.*	12,1 [16.2]	12 [16.1]	12 [16.1]	9 [12.1]	7,8 [10.5]	7,2 [9.7]	5,6 [7.5]
<b>Max. Pressure Drop bar [PSI]</b>	Cont.	140 [2030]	140 [2030]	110 [1600]	90 [1300]	70 [1015]	60 [870]	55 [800]
	Int.*	175 [2540]	175 [2540]	175 [2540]	140 [2030]	115 [1665]	90 [1305]	80 [1160]
	Peak**	225 [3260]	225 [3260]	225 [3260]	225 [3260]	180 [2610]	130 [1885]	110 [1740]
<b>Max. Oil Flow lpm [GPM]</b>	Cont.	60 [15.9]	60 [15.9]	60 [15.9]	60 [15.9]	60 [15.9]	60 [15.9]	60 [15.9]
	Int.*	75 [19.8]	75 [19.8]	75 [19.8]	75 [19.8]	75 [19.8]	75 [19.8]	75 [19.8]
<b>Max. Inlet Pressure bar [PSI]</b>	Cont.	175 [2540]	175 [2540]	175 [2540]	175 [2540]	175 [2540]	140 [2030]	140 [2030]
	Int.*	200 [2900]	200 [2900]	200 [2900]	200 [2900]	200 [2900]	175 [2540]	175 [2540]
	Peak**	225 [3260]	225 [3260]	225 [3260]	225 [3260]	225 [3260]	225 [3260]	225 [3260]
<b>Max. Return Pressure with Drain Line bar [PSI]</b>	Cont.	175 [2540]	175 [2540]	175 [2540]	175 [2540]	175 [2540]	140 [2030]	140 [2030]
	Int.*	200 [2900]	200 [2900]	200 [2900]	200 [2900]	200 [2900]	175 [2540]	175 [2540]
	Peak**	225 [3260]	225 [3260]	225 [3260]	225 [3260]	225 [3260]	225 [3260]	225 [3260]
<b>Max. Starting Pressure with Unloaded Shaft, bar [PSI]</b>		8 [116]	7 [100]	6 [87]	5 [73]	5 [73]	5 [73]	5 [73]
<b>Min. Starting Torque daNm [lb-in]</b>	At max.press. drop Cont.	28,2 [2500]	33,5 [2950]	33,6 [2970]	34,4 [3045]	34,5 [3050]	36 [3180]	41,5 [3670]
	At max.press. drop Int.*	35,5 [3140]	42,6 [3770]	54,2 [4795]	61,9 [5480]	60,8 [5390]	54 [4780]	62 [5480]
<b>Min. Speed***, [RPM]</b>		10	10	10	10	10	10	10
<b>Weight, kg [lb] For rear ports +0,450 [.992]</b>	MP(F)(N)	6,4 [14.1]	6,6 [14.6]	6,8 [15]	7,1 [15.6]	7,6 [16.8]	8,9 [20]	9,5 [21.4]
	MPW(N)	6,1 [13.5]	6,3 [13.9]	6,5 [14.3]	6,8 [15]	7,2 [15.9]	8,6 [19]	9,2 [20.3]
	MPQ(N)	5,8 [12.8]	6 [13.2]	6,2 [13.7]	6,5 [14.3]	6,8 [15]	8,3 [18.3]	9 [19.8]

\* Intermittent operation: the permissible values may occur for max. 10% of every minute.

\*\* Peak load: the permissible values may occur for max. 1% of every minute.

\*\*\* For speeds lower than given, consult factory or your regional manager.

- Intermittent speed and intermittent pressure must not occur simultaneously.
- Recommended filtration is per ISO cleanliness code 20/16. A nominal filtration of 25 micron or better.
- Recommend using a premium quality, anti-wear type mineral based hydraulic oil HLP(DIN51524) or HM (ISO 6743/4).  
If using synthetic fluids consult the factory for alternative seal materials.
- Recommended minimum oil viscosity 13 mm<sup>2</sup>/s [70 SUS] at 50°C [122°F].
- Recommended maximum system operating temperature is 82°C [180°F].
- To assure optimum motor life fill with fluid prior to loading and run at moderate load and speed for 10-15 minutes.

## SPECIFICATION DATA (continued)

Specification Data for MP... motors with **CB, KB, OB** and **HB** shafts.  
( $\varnothing 35$  sealing diameter)

Type		MP 80	MP 100	MP 125	MP 160	MP 200
<b>Displacement, cm<sup>3</sup>/rev [in<sup>3</sup>/rev]</b>		79,2 [4.83]	99 [6.04]	123,8 [7.55]	158,4 [9.66]	198 [12.1]
<b>Max. Speed, [RPM]</b>	Cont.	755	605	486	378	303
	Int.*	945	755	605	472	378
<b>Max. Torque daNm [lb-in]</b>	Cont.	15,1 [1340]	19,3 [1710]	23,7 [2100]	31,3 [2770]	36,6 [3240]
	Int.*	19,5 [1725]	23,7 [2100]	29,8 [2640]	37,8 [3345]	45,6 [4035]
	Peak**	22,4 [1985]	27,5 [2435]	36,5 [3235]	43,8 [3880]	55 [4870]
<b>Max. Output kW [HP]</b>	Cont.	10,2 [13.7]	10,5 [14.1]	10,2 [13.7]	10,1 [13.5]	10 [13.5]
	Int.*	12,5 [16.8]	12,8 [17.1]	12 [16.1]	12,1 [16.2]	12 [16.1]
<b>Max. Pressure Drop bar [PSI]</b>	Cont.	140 [2030]	140 [2030]	140 [2030]	140 [2030]	140 [2030]
	Int.*	175 [2540]	175 [2540]	175 [2540]	175 [2540]	175 [2540]
	Peak**	225 [3260]	225 [3260]	225 [3260]	225 [3260]	225 [3260]
<b>Max. Oil Flow lpm [GPM]</b>	Cont.	60 [15.9]	60 [15.9]	60 [15.9]	60 [15.9]	60 [15.9]
	Int.*	75 [19.8]	75 [19.8]	75 [19.8]	75 [19.8]	75 [19.8]
<b>Max. Inlet Pressure bar [PSI]</b>	Cont.	175 [2540]	175 [2540]	175 [2540]	175 [2540]	175 [2540]
	Int.*	200 [2900]	200 [2900]	200 [2900]	200 [2900]	200 [2900]
	Peak**	225 [3260]	225 [3260]	225 [3260]	225 [3260]	225 [3260]
<b>Max. Return Pressure with Drain Line bar [PSI]</b>	Cont.	175 [2540]	175 [2540]	175 [2540]	175 [2540]	175 [2540]
	Int.*	200 [2900]	200 [2900]	200 [2900]	200 [2900]	200 [2900]
	Peak**	225 [3260]	225 [3260]	225 [3260]	225 [3260]	225 [3260]
<b>Max. Starting Pressure with Unloaded Shaft, bar [PSI]</b>		10 [145]	10 [145]	9 [131]	8 [116]	7 [100]
<b>Min. Starting Torque daNm [lb-in]</b>	At max.press. drop Cont.	13,2 [1170]	16,6 [1470]	20,7 [1830]	28,2 [2500]	33,5 [2950]
	At max.press. drop Int.*	16,8 [1490]	21 [1860]	26,6 [2360]	35,5 [3140]	42,6 [3770]
<b>Min. Speed***, [RPM]</b>		10	10	10	10	10
<b>Weight, kg [lb] For rear ports +0,450 [.992]</b>	MP(F)...B	6 [13.2]	6,2 [13.7]	6,3 [13.9]	6,5 [14.3]	6,7 [14.8]

\* Intermittent operation: the permissible values may occur for max. 10% of every minute.

\*\* Peak load: the permissible values may occur for max. 1% of every minute.

\*\*\* For speeds lower than given, consult factory or your regional manager.

1. Intermittent speed and intermittent pressure must not occur simultaneously.
2. Recommended filtration is per ISO cleanliness code 20/16. A nominal filtration of 25 micron or better.
3. Recommend using a premium quality, anti-wear type mineral based hydraulic oil HLP(DIN51524) or HM (ISO 6743/4). If using synthetic fluids consult the factory for alternative seal materials.
4. Recommended minimum oil viscosity 13 mm<sup>2</sup>/s [70 SUS] at 50°C [122°F].
5. Recommended maximum system operating temperature is 82°C [180°F].
6. To assure optimum motor life fill with fluid prior to loading and run at moderate load and speed for 10-15 minutes.

## SPECIFICATION DATA (continued)

Specification Data for MP... motors with **CB, KB, OB** and **HB** shafts.  
( $\varnothing 35$  sealing diameter)

Type		MP 250	MP 315	MP 400	MP 500	MP 630
<b>Displacement, cm<sup>3</sup>/rev [in<sup>3</sup>/rev]</b>		247,5 [15.1]	316,8 [19.3]	396 [24.16]	495 [30.2]	623,6 [38.05]
<b>Max. Speed, [RPM]</b>	Cont.	242	190	150	120	95
	Int.*	303	236	189	150	120
<b>Max. Torque daNm [lb-in]</b>	Cont.	47 [4160]	48 [4360]	50 [4415]	39 [3452]	44 [3895]
	Int.*	58,3 [5160]	56 [4960]	59 [5240]	57 [5045]	64 [5665]
	Peak**	68,5 [6060]	85 [7505]	85,4 [7560]	78 [6903]	82 [7257]
<b>Max. Output kW [HP]</b>	Cont.	9 [12.1]	7,6 [10.2]	6,2 [8.3]	3,5 [4.7]	3,3 [4.4]
	Int.*	12 [16.1]	9 [12.1]	7,8 [10.5]	7,2 [9.7]	5,6 [7.5]
<b>Max. Pressure Drop bar [PSI]</b>	Cont.	140 [2030]	120 [1740]	95 [1400]	60 [870]	55 [800]
	Int.*	175 [2540]	140 [2030]	115 [1670]	90 [1305]	80 [1160]
	Peak**	225 [3260]	225 [3260]	180 [2610]	130 [1885]	110 [1740]
<b>Max. Oil Flow lpm [GPM]</b>	Cont.	60 [15.9]	60 [15.9]	60 [15.9]	60 [15.9]	60 [15.9]
	Int.*	75 [19.8]	75 [19.8]	75 [19.8]	75 [19.8]	75 [19.8]
<b>Max. Inlet Pressure bar [PSI]</b>	Cont.	175 [2540]	175 [2540]	175 [2540]	140 [2030]	140 [2030]
	Int.*	200 [2900]	200 [2900]	200 [2900]	175 [2540]	175 [2540]
	Peak**	225 [3260]	225 [3260]	225 [3260]	225 [3260]	225 [3260]
<b>Max. Return Pressure with Drain Line bar [PSI]</b>	Cont.	175 [2540]	175 [2540]	175 [2540]	140 [2030]	140 [2030]
	Int.*	200 [2900]	200 [2900]	200 [2900]	175 [2540]	175 [2540]
	Peak**	225 [3260]	225 [3260]	225 [3260]	225 [3260]	225 [3260]
<b>Max. Starting Pressure with Unloaded Shaft, bar [PSI]</b>		6 [87]	5 [73]	5 [73]	5 [73]	5 [73]
<b>Min. Starting Torque daNm [lb-in]</b>	At max.press. drop Cont.	42,8 [3790]	4050 [45,8]	46,8 [4140]	36 [3180]	41,5 [3670]
	At max.press. drop Int.*	54,2 [4795]	5480 [61,9]	60,8 [5390]	54 [4780]	62 [5480]
<b>Min. Speed***, [RPM]</b>		10	10	10	10	10
<b>Weight, kg [lb] For rear ports +0,450 [.992]</b>	MP(F)...B	6,9 [15.2]	7,2 [15.9]	7,7 [17]	9,0 [19.9]	9,6 [21.2]

\* Intermittent operation: the permissible values may occur for max. 10% of every minute.

\*\* Peak load: the permissible values may occur for max. 1% of every minute.

\*\*\* For speeds lower than given, consult factory or your regional manager.

- Intermittent speed and intermittent pressure must not occur simultaneously.
- Recommended filtration is per ISO cleanliness code 20/16. A nominal filtration of 25 micron or better.
- Recommend using a premium quality, anti-wear type mineral based hydraulic oil HLP(DIN51524) or HM ( ISO 6743/4).  
If using synthetic fluids consult the factory for alternative seal materials.
- Recommended minimum oil viscosity 13 mm<sup>2</sup>/s [70 SUS] at 50°C [122°F].
- Recommended maximum system operating temperature is 82°C [180°F].
- To assure optimum motor life fill with fluid prior to loading and run at moderate load and speed for 10-15 minutes.

**FUNCTION DIAGRAMS**

**MP 25**

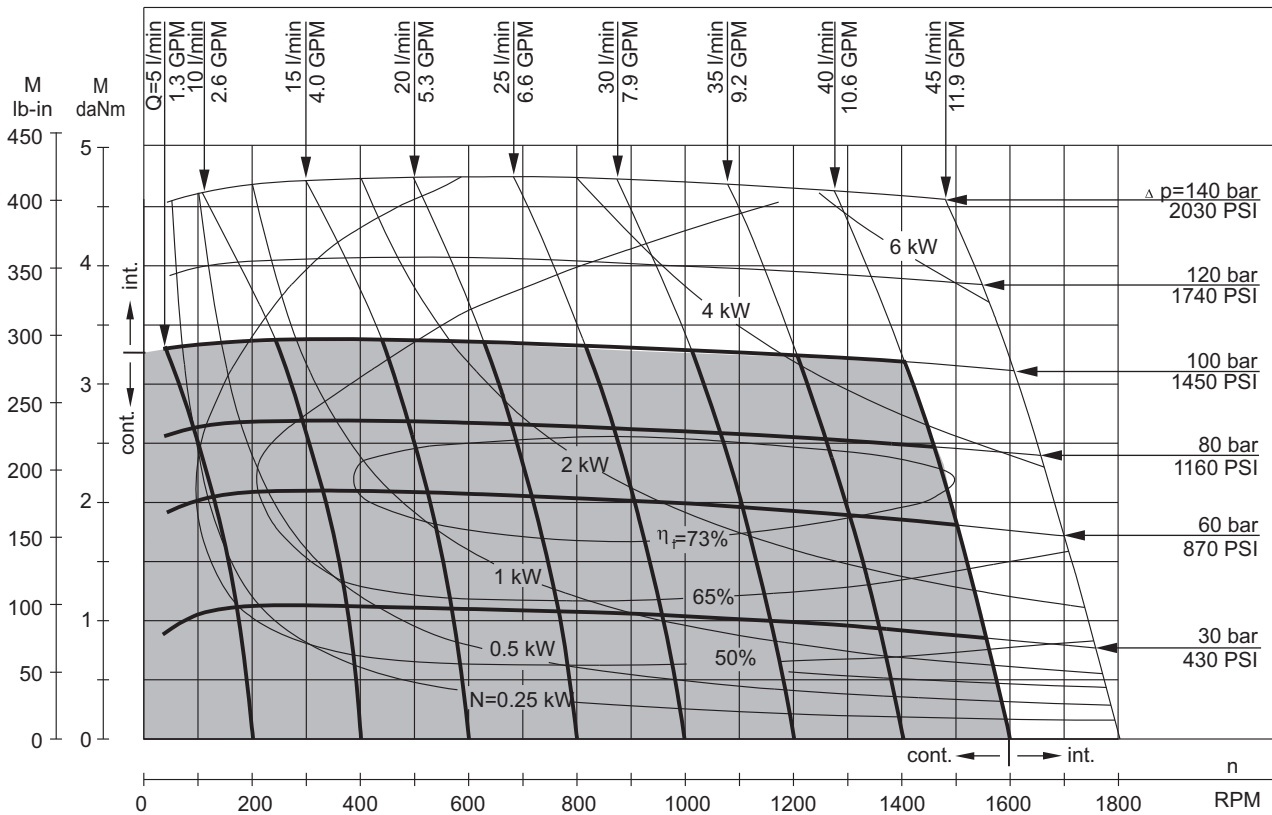

**MP 32**

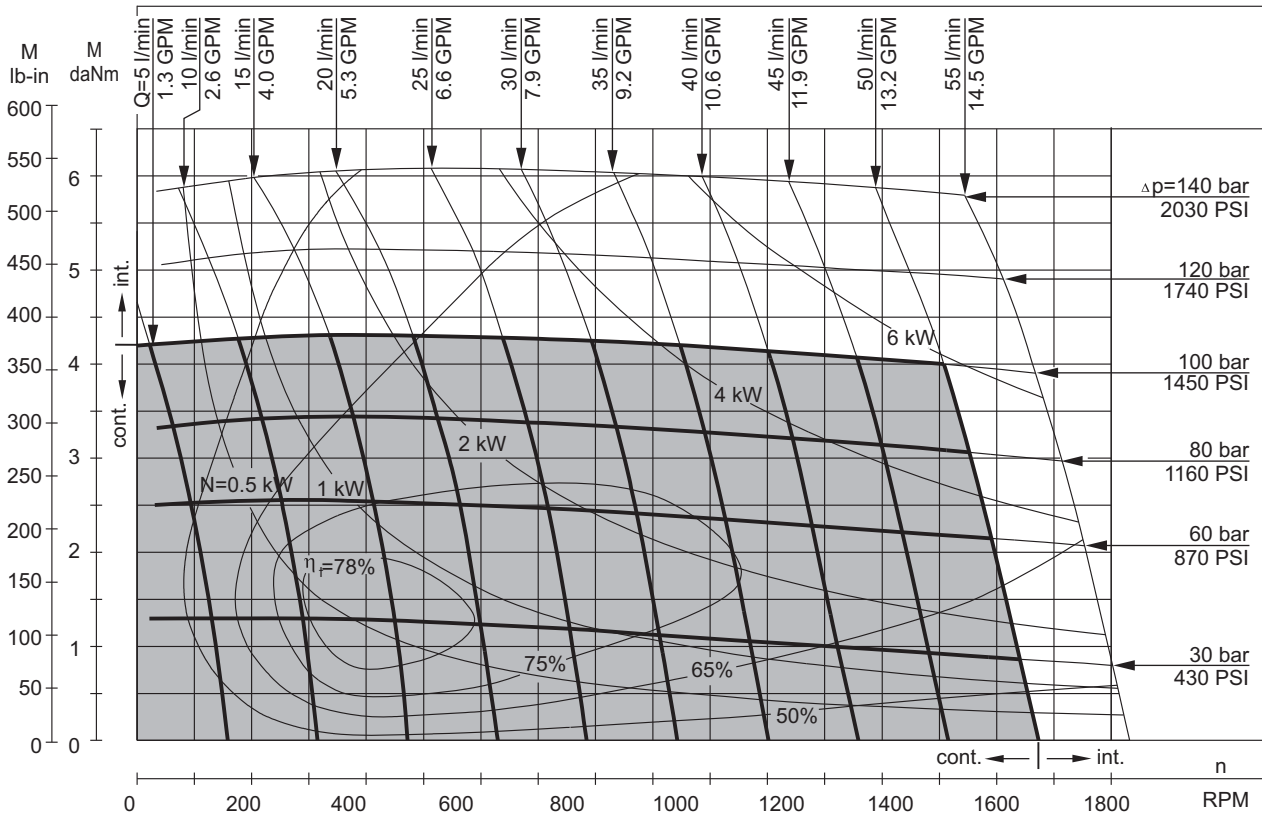

The function diagrams data is for average performance of randomly selected motors at back pressure 5÷10 bar [72.5÷145 PSI] and oil with viscosity of 32 mm<sup>2</sup>/s [150 SUS] at 50°C [122°F].

**FUNCTION DIAGRAMS**

**MP 40**

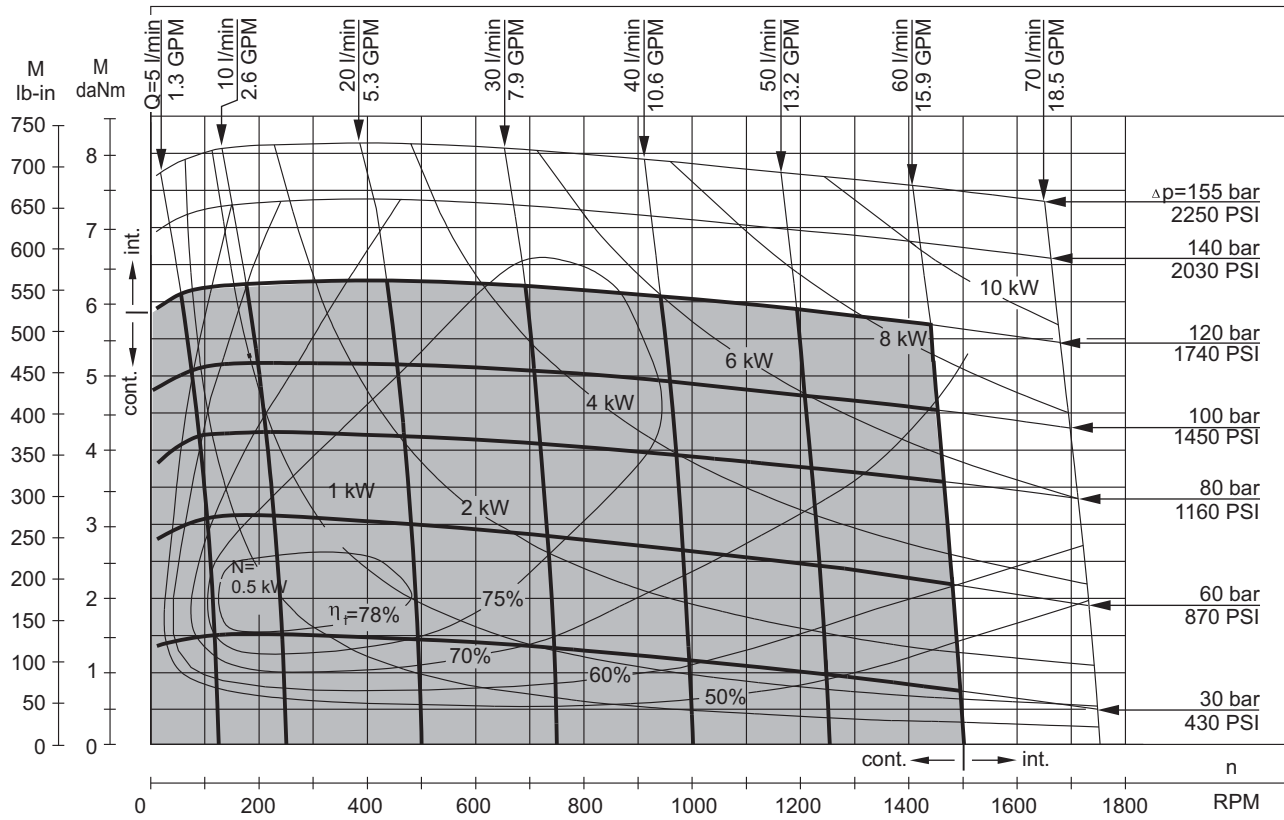

**MP 50**

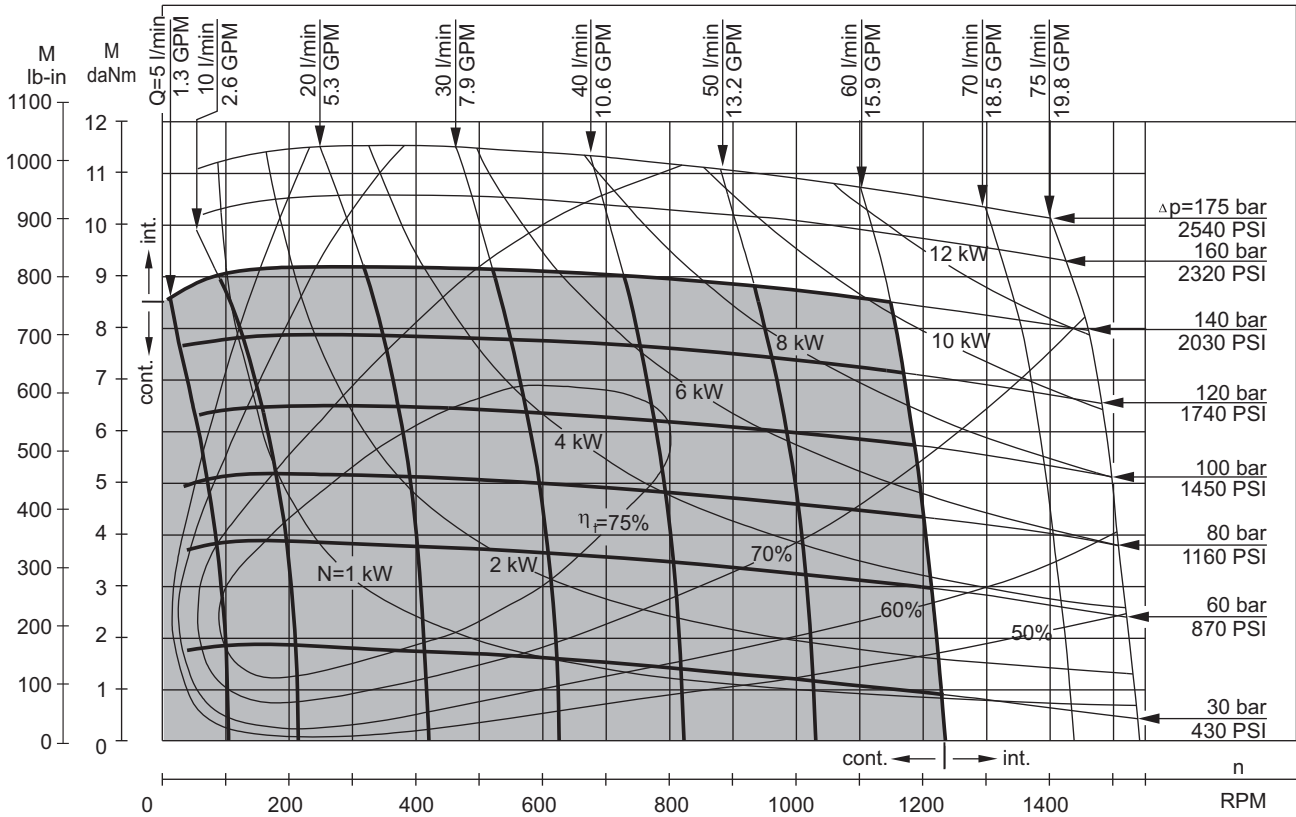

The function diagrams data is for average performance of randomly selected motors at back pressure 5÷10 bar [72.5÷145 PSI] and oil with viscosity of 32 mm<sup>2</sup>/s [150 SUS] at 50°C [122°F].

**FUNCTION DIAGRAMS**

**MP 80**

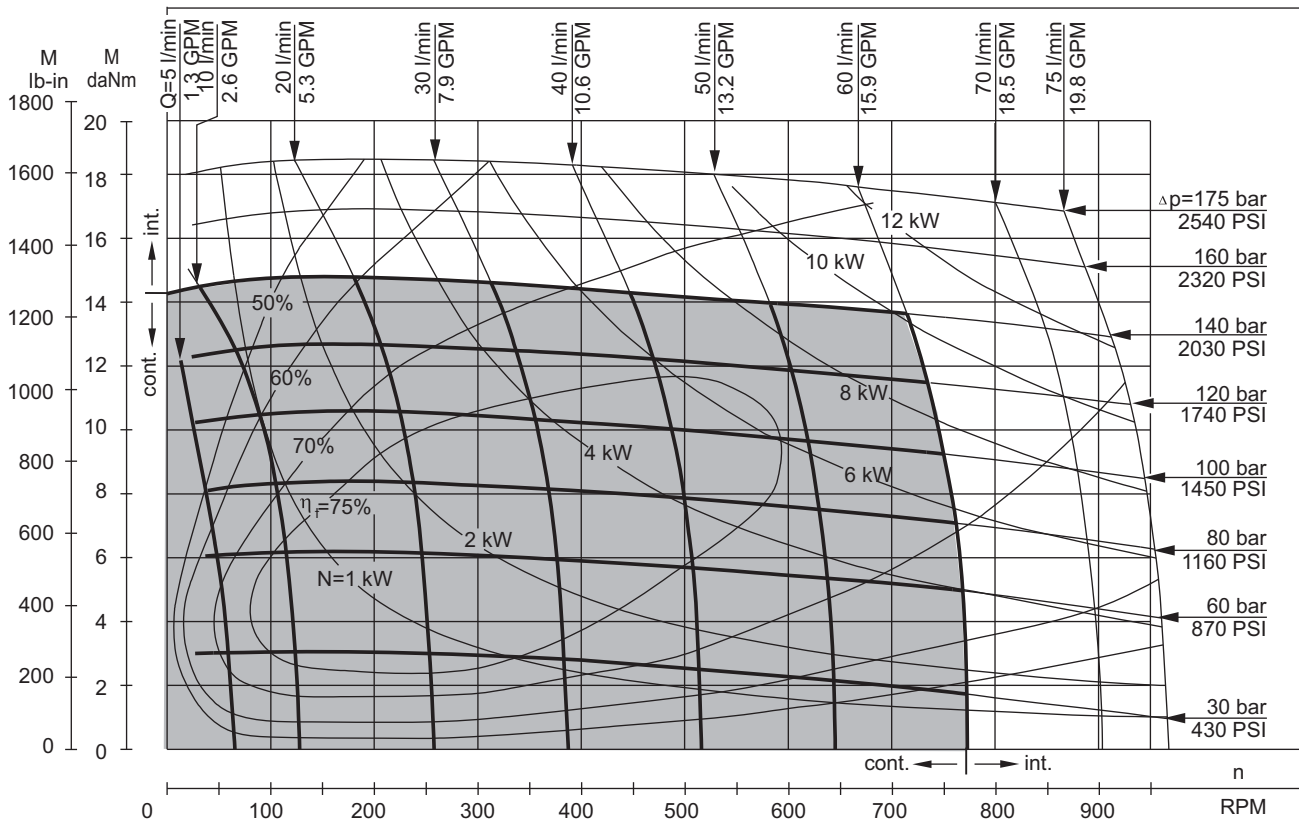

**MP 100**

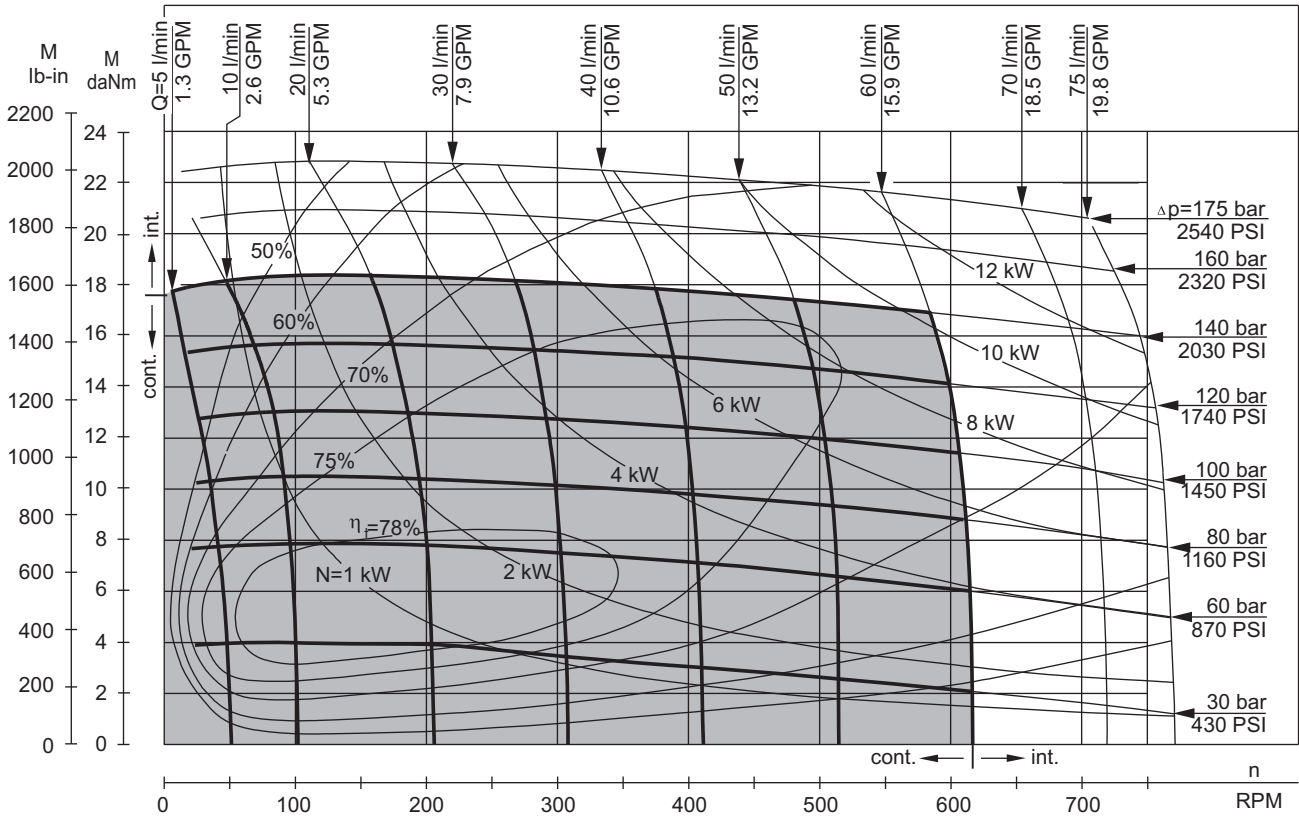

The function diagrams data is for average performance of randomly selected motors at back pressure 5÷10 bar [72.5÷145 PSI] and oil with viscosity of 32 mm<sup>2</sup>/s [150 SUS] at 50°C [122°F].

**FUNCTION DIAGRAMS**

**MP 125**

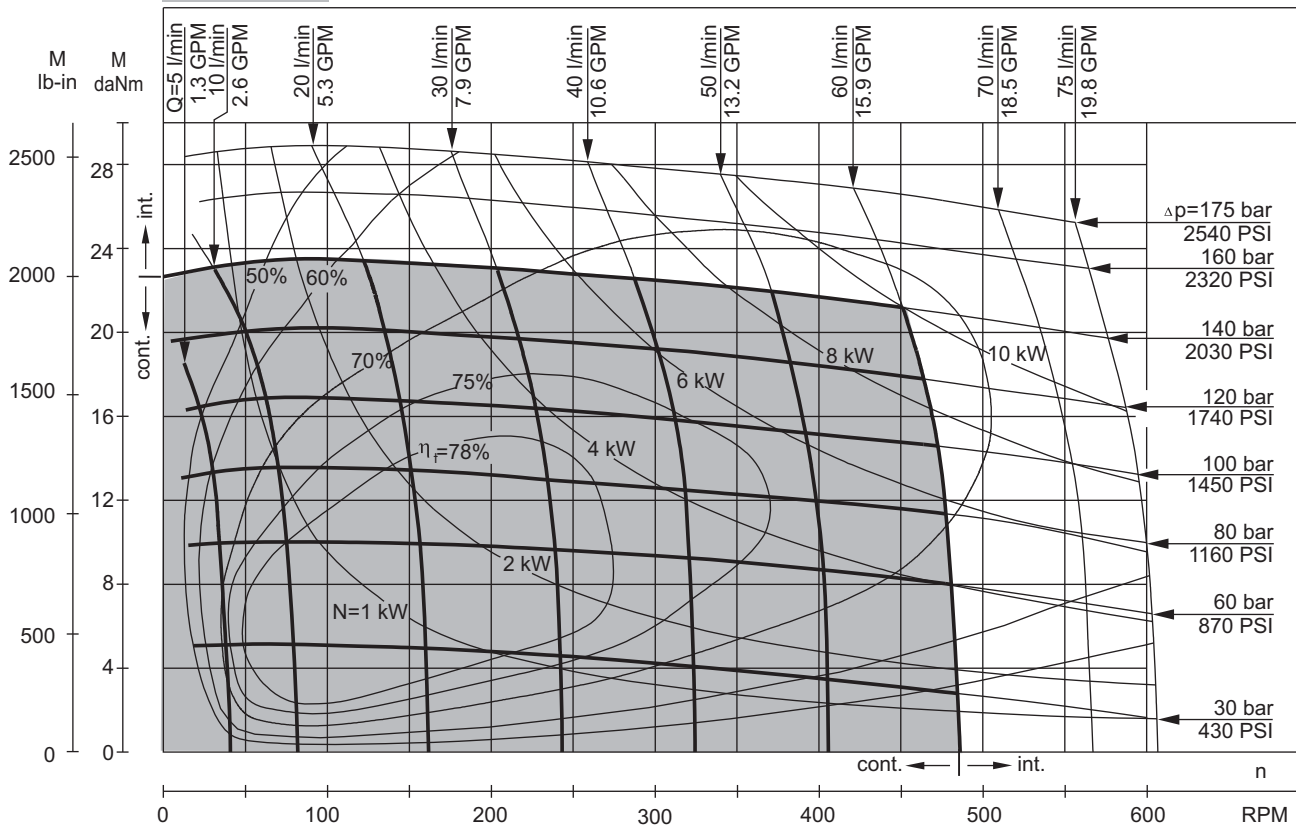

**MP 160**

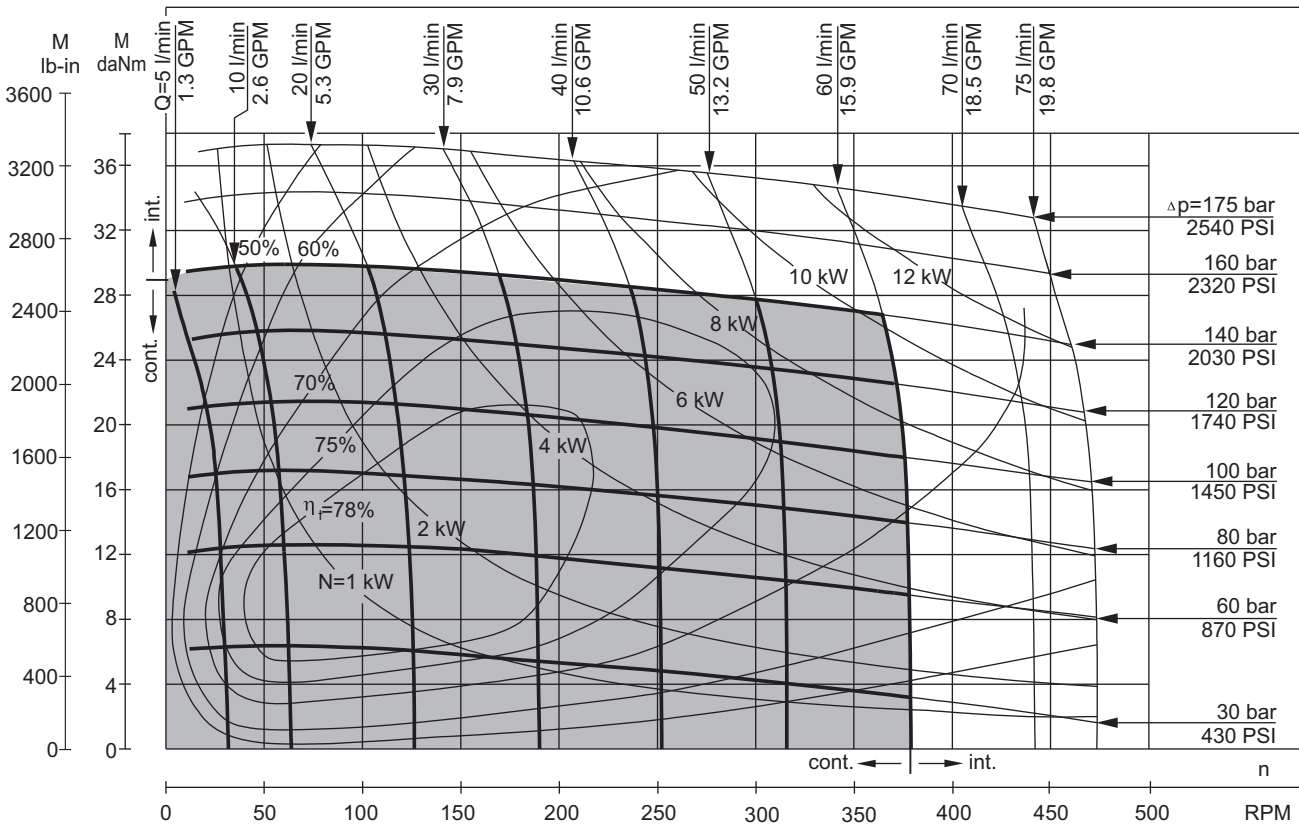

The function diagrams data is for average performance of randomly selected motors at back pressure 5÷10 bar [72.5÷145 PSI] and oil with viscosity of 32 mm<sup>2</sup>/s [150 SUS] at 50°C [122°F].

**FUNCTION DIAGRAMS**

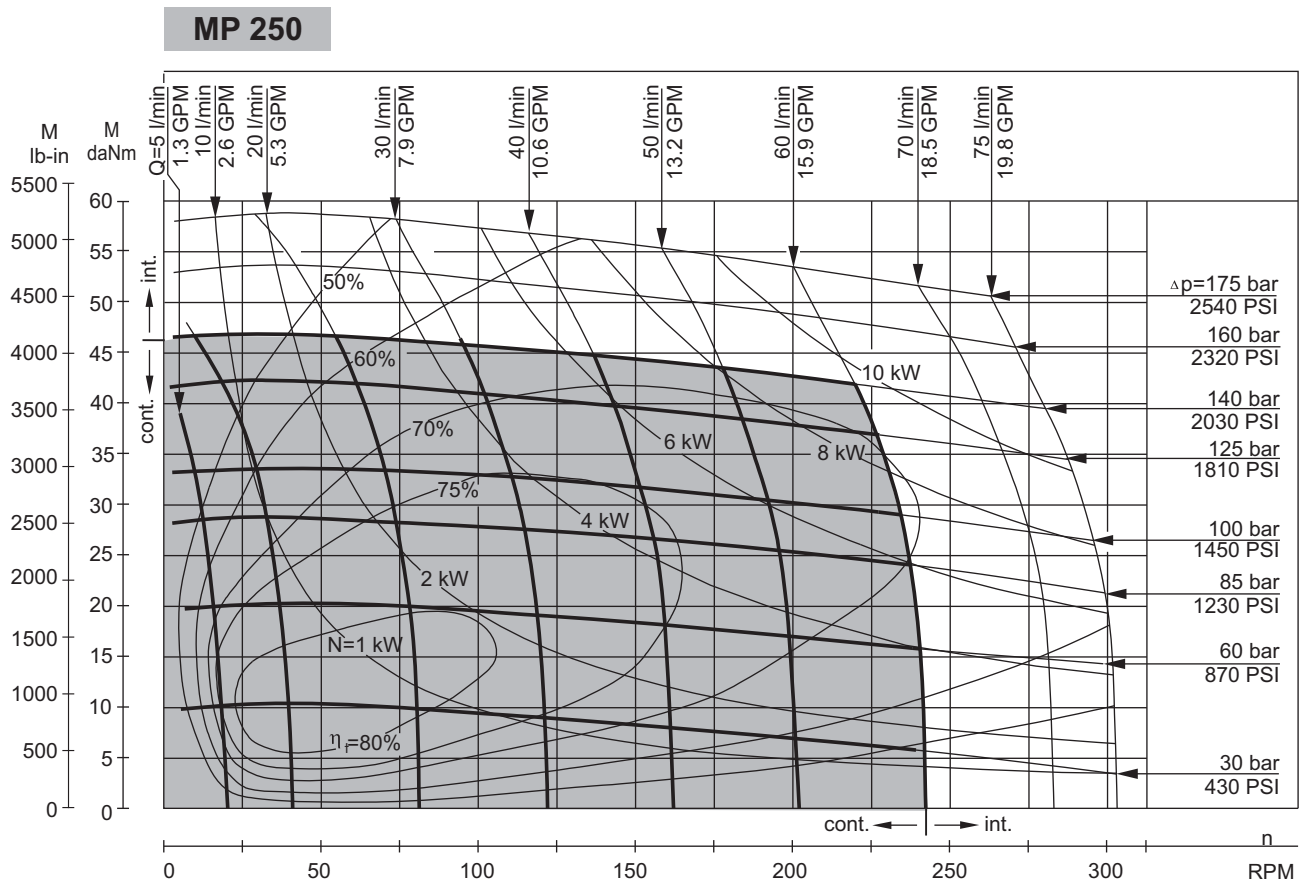
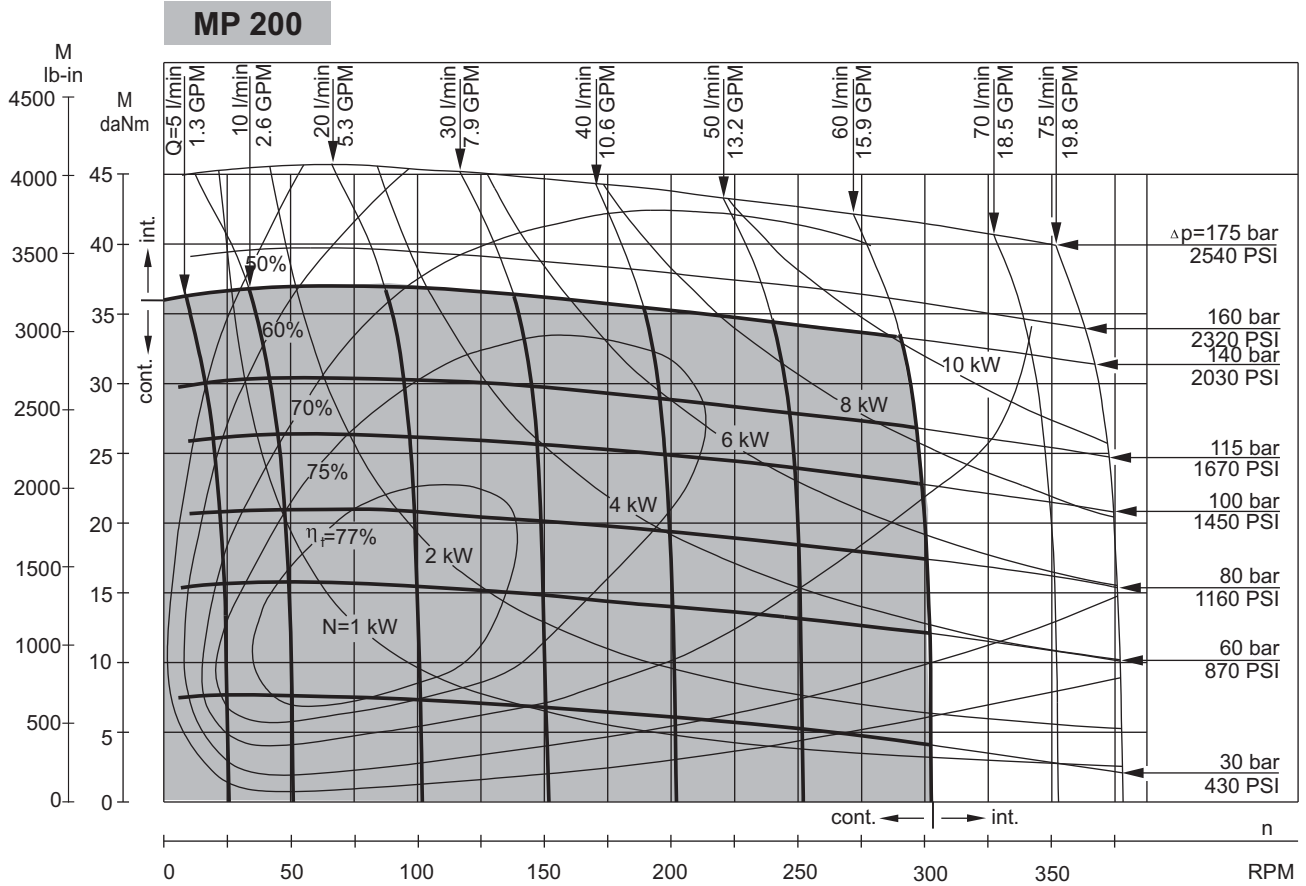

The function diagrams data is for average performance of randomly selected motors at back pressure 5÷10 bar [72.5÷145 PSI] and oil with viscosity of 32 mm<sup>2</sup>/s [150 SUS] at 50°C [122°F].

**FUNCTION DIAGRAMS**

**MP 315**

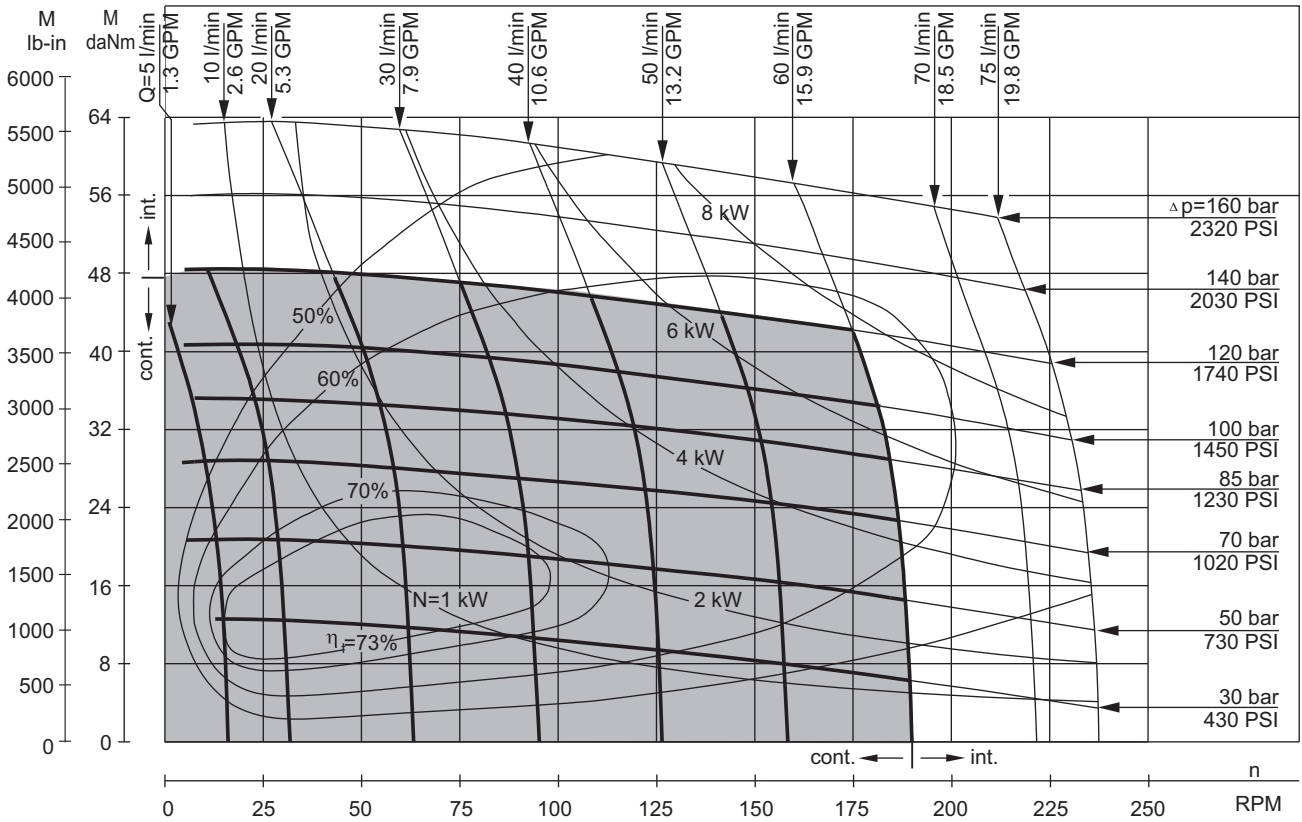

**MP 400**

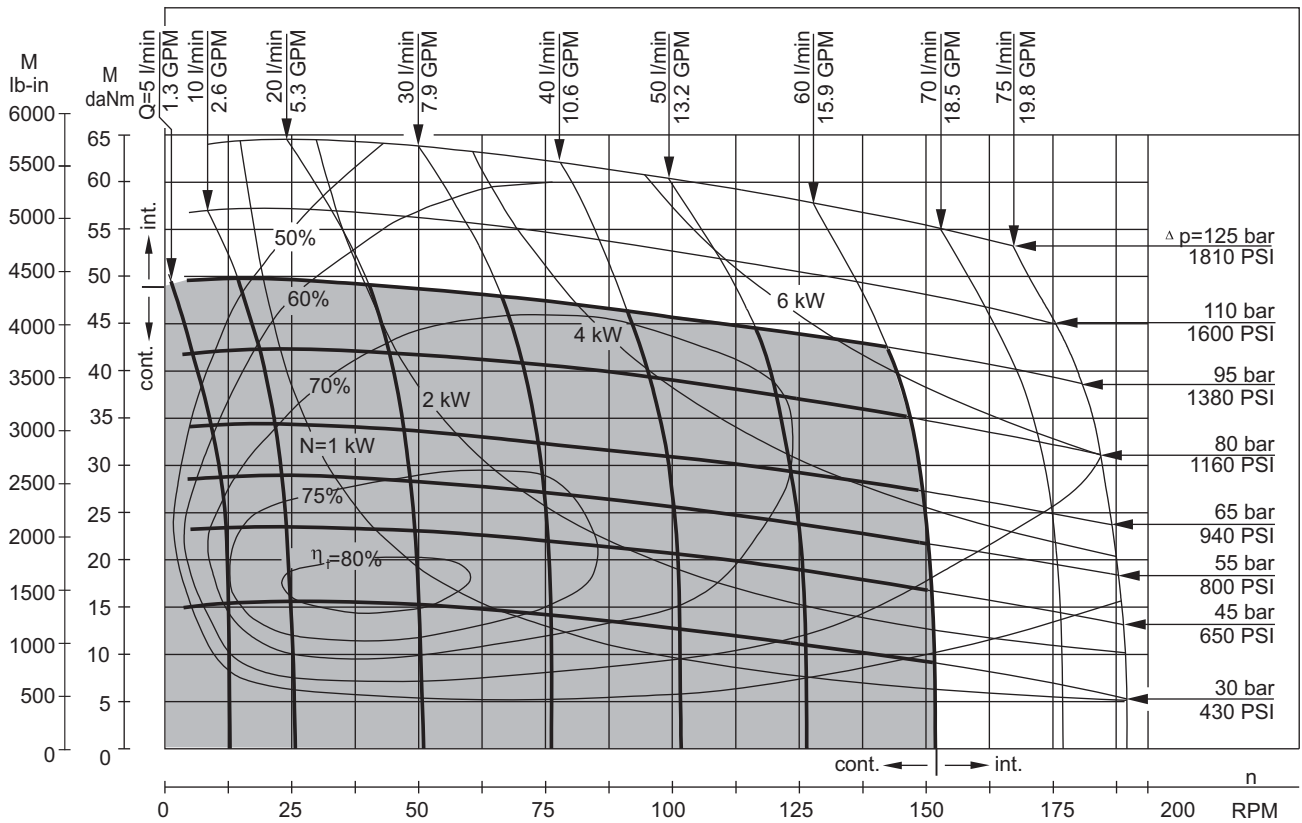

The function diagrams data is for average performance of randomly selected motors at back pressure 5÷10 bar [72.5÷145 PSI] and oil with viscosity of 32 mm<sup>2</sup>/s [150 SUS] at 50°C [122°F].

**FUNCTION DIAGRAMS**

**MP 500**

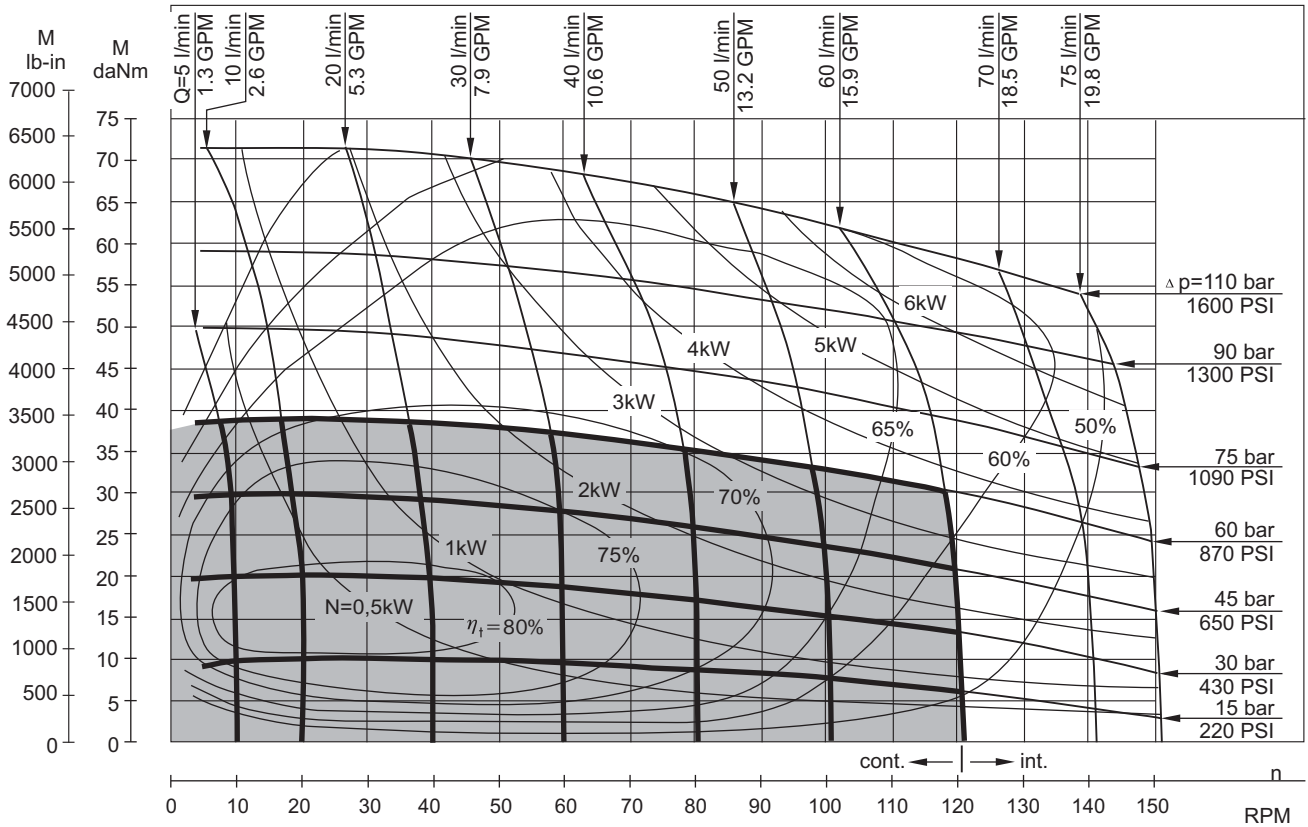

**MP 630**

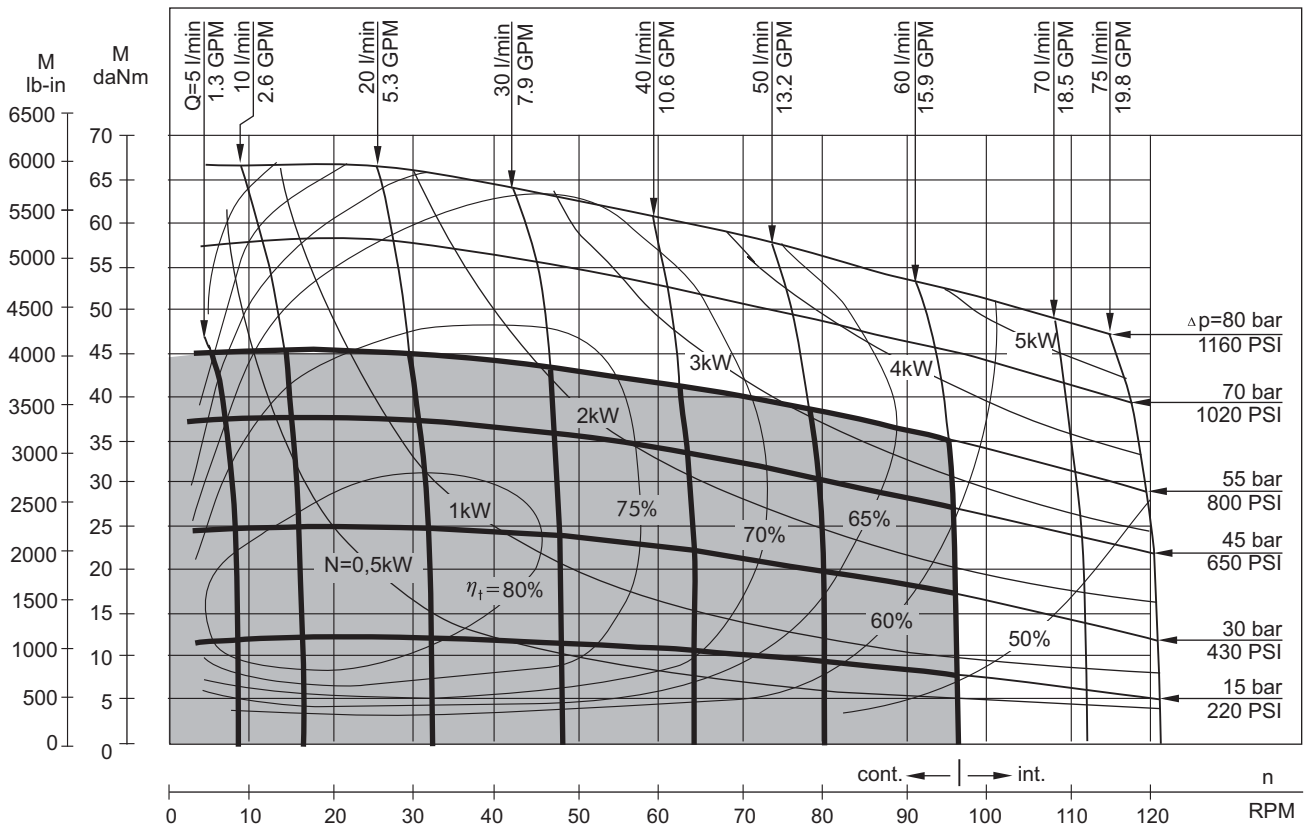

The function diagrams data is for average performance of randomly selected motors at back pressure 5÷10 bar [72.5÷145 PSI] and oil with viscosity of 32 mm<sup>2</sup>/s [150 SUS] at 50°C [122°F].

**DIMENSIONS AND MOUNTING DATA**

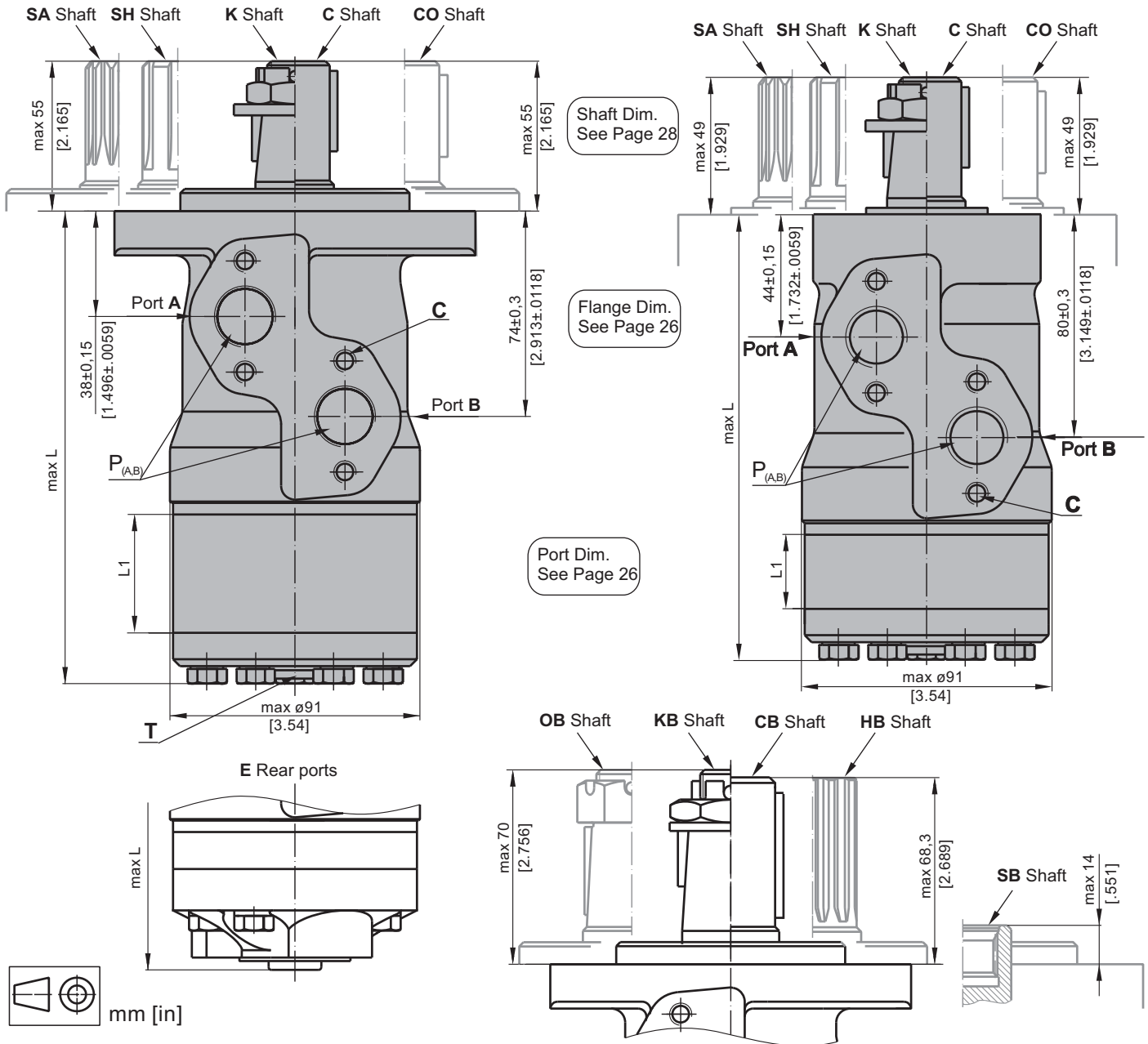

**C** : 4xM8 - 13 mm [.51 in] depth  
**P<sub>(A,B)</sub>** : 2xG1/2 or 2xM22x1,5 - 15 mm [.59 in] depth  
**T** : G1/4 or M14x1,5 - 12 mm [.47 in] depth (plugged)

**Standard Rotation**  
 Viewed from Shaft End  
 Port A Pressurized - **CW**  
 Port B Pressurized - **CCW**

**Reverse Rotation**  
 Viewed from Shaft End  
 Port A Pressurized - **CCW**  
 Port B Pressurized - **CW**

Type	L, mm [in]	Type	L, mm [in]	Type	L, mm [in]	Type	L, mm [in]	L <sub>1</sub> , mm [in]
MP(F) 25	134,0 [5.28]	MPQ 25	140,5 [5.53]	MP(F)E 25	150,0 [5.91]	MPQE 25	156,5 [6.16]	5,20 [.21]
MP(F) 32	135,0 [5.31]	MPQ 32	141,5 [5.57]	MP(F)E 32	151,5 [5.96]	MPQE 32	157,5 [6.20]	6,30 [.25]
MP(F) 40	136,5 [5.37]	MPQ 40	142,5 [5.61]	MP(F)E 40	152,5 [6.00]	MPQE 40	158,5 [6.24]	7,40 [.29]
MP(F) 50	135,5 [5.33]	MPQ 50	142,0 [5.59]	MP(F)E 50	151,5 [5.96]	MPQE 50	158,0 [6.22]	6,67 [.26]
MP(F) 80	139,5 [5.49]	MPQ 80	146,0 [5.75]	MP(F)E 80	155,5 [6.12]	MPQE 80	162,0 [6.38]	10,67 [.42]
MP(F) 100	142,0 [5.59]	MPQ 100	148,5 [5.85]	MP(F)E 100	158,5 [6.24]	MPQE 100	164,5 [6.48]	13,33 [.52]
MP(F) 125	145,5 [5.73]	MPQ 125	152,0 [5.98]	MP(F)E 125	161,5 [6.36]	MPQE 125	168,0 [6.61]	16,67 [.66]
MP(F) 160	150,0 [5.91]	MPQ 160	156,5 [6.16]	MP(F)E 160	166,5 [6.56]	MPQE 160	172,5 [6.79]	21,33 [.84]
MP(F) 200	155,5 [6.12]	MPQ 200	162,0 [6.38]	MP(F)E 200	171,5 [6.75]	MPQE 200	178,0 [7.01]	26,67 [1.05]
MP(F) 250	162,0 [6.38]	MPQ 250	168,5 [6.63]	MP(F)E 250	178,5 [7.03]	MPQE 250	184,5 [7.26]	33,33 [1.31]
MP(F) 315	171,5 [6.75]	MPQ 315	178,0 [7.01]	MP(F)E 315	187,5 [7.38]	MPQE 315	194,0 [7.64]	42,67 [1.68]
MP(F) 400	182,0 [7.17]	MPQ 400	188,5 [7.42]	MP(F)E 400	198,5 [7.81]	MPQE 400	204,5 [8.05]	53,33 [2.10]
MP(F) 500	195,5 [7.70]	MPQ 500	202,0 [7.95]	MP(F)E 500	211,5 [8.33]	MPQE 500	218,0 [8.58]	66,63 [2.62]
MP(F) 630	213,0 [8.39]	MPQ 630	219,0 [8.62]	MP(F)E 630	229,0 [9.02]	MPQE 630	235,0 [9.25]	84,00 [3.31]

**MOUNTING**

Oval Mount (2 Holes)

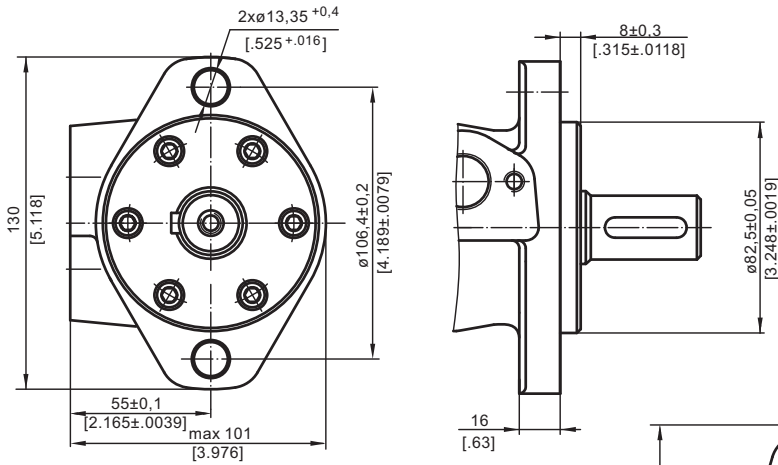

**F** - Oval Mount (4 Holes)

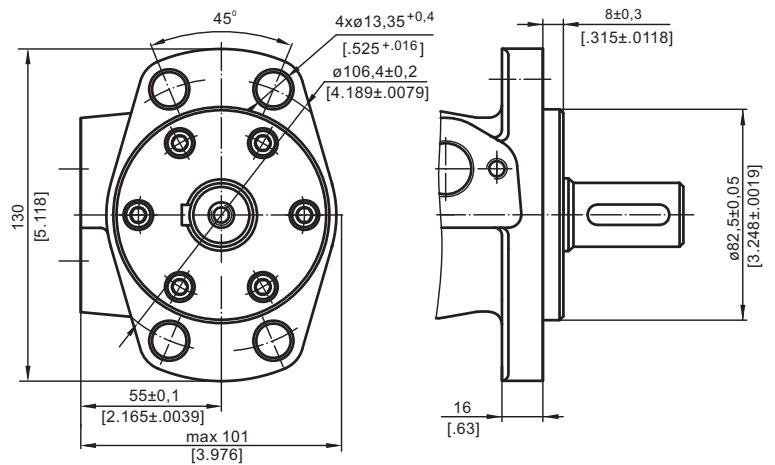

**Q** - Square Mount (4 Bolts)

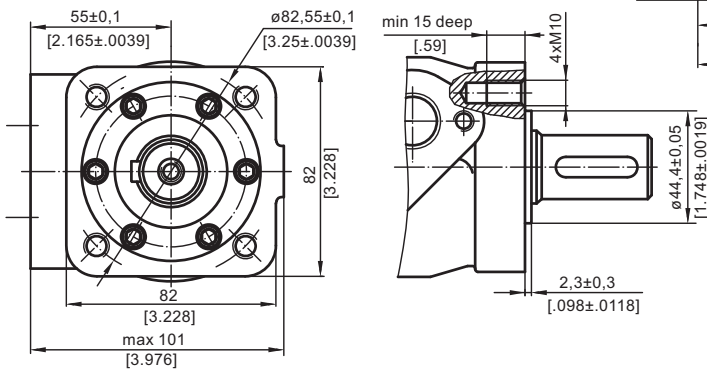

**PORTS**

Side Ports

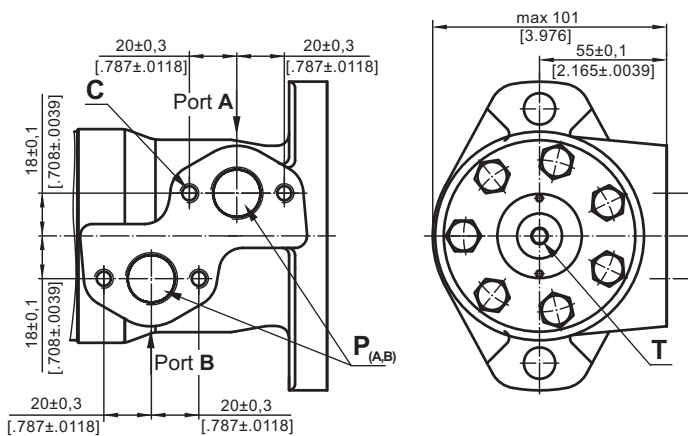

**E** Rear Ports

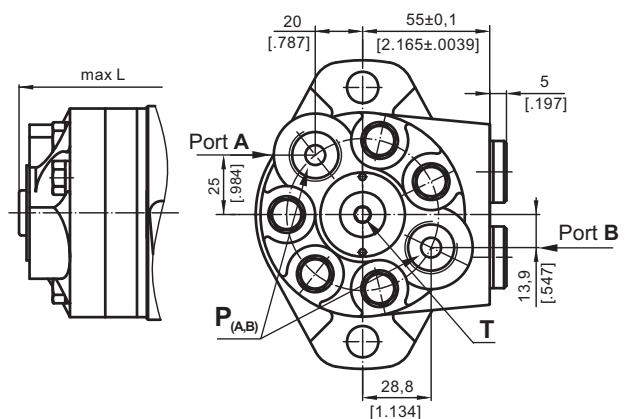

- C** : 4xM8 - 13 mm [.51 in] depth
- P<sub>(A,B)</sub>**: 2xG1/2 or 2xM22x1,5 - 15 mm [.59 in] depth
- T** : G1/4 or M14x1,5 - 12 mm [.47 in] depth (plugged)

**Standard Rotation**  
Viewed from Shaft End  
Port A Pressurized - CW  
Port B Pressurized - CCW

**Reverse Rotation**  
Viewed from Shaft End  
Port A Pressurized - CCW  
Port B Pressurized - CW

**DIMENSIONS AND MOUNTING DATA - MPW**

**W - Wheel Mount**

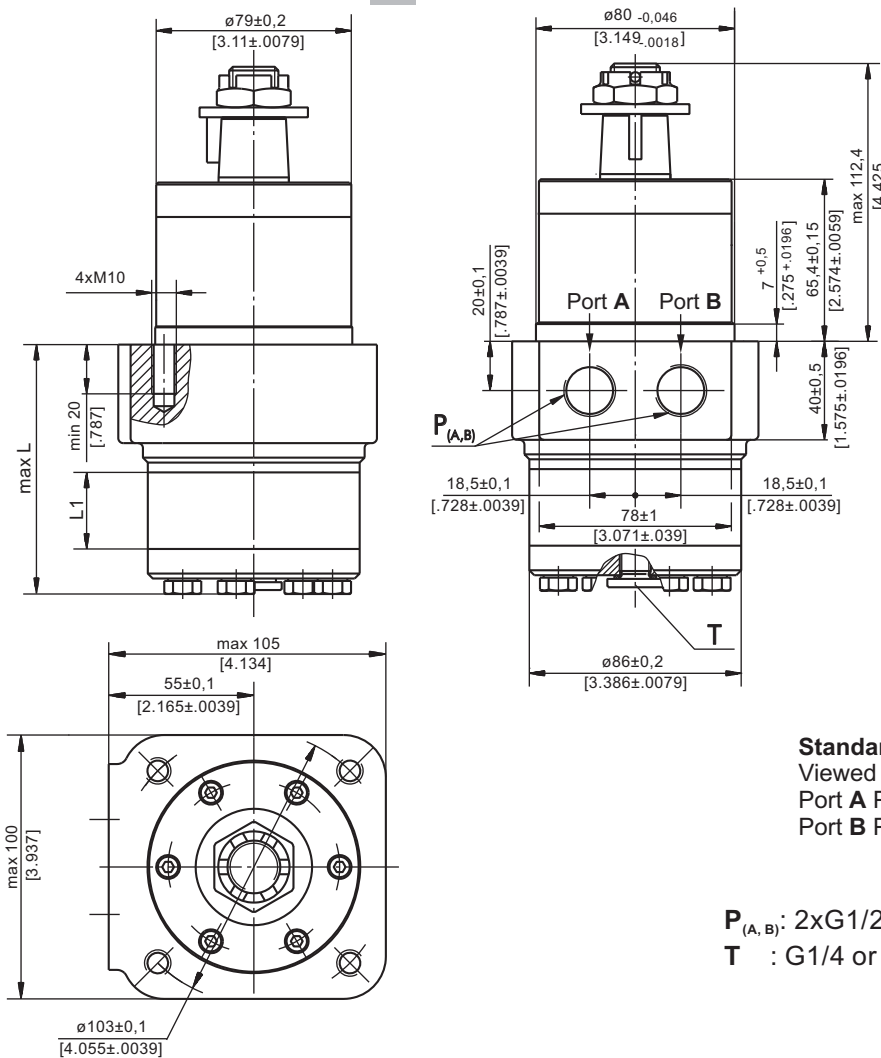

Type	L, mm [in]	L <sub>1</sub> , mm [in]
MPW 25	77,0 [3.03]	5,20 [.21]
MPW 32	78,0 [3.07]	6,30 [.25]
MPW 40	79,5 [3.13]	7,40 [.29]
MPW 50	78,5 [3.09]	6,67 [.26]
MPW 80	82,5 [3.25]	10,67 [.42]
MPW 100	85,0 [3.35]	13,33 [.52]
MPW 125	88,5 [3.48]	16,67 [.66]
MPW 160	93,0 [3.66]	21,33 [.84]
MPW 200	98,5 [3.88]	26,67 [1.05]
MPW 250	105,0 [4.13]	33,33 [1.31]
MPW 315	114,5 [4.51]	42,67 [1.68]
MPW 400	125,0 [4.92]	53,33 [2.10]
MPW 500	138,5 [5.45]	66,63 [2.62]
MPW 630	156,0 [6.14]	84,00 [3.31]



**Standard Rotation**  
Viewed from Shaft End  
Port A Pressurized - **CW**  
Port B Pressurized - **CCW**

**Reverse Rotation**  
Viewed from Shaft End  
Port A Pressurized - **CCW**  
Port B Pressurized - **CW**

**P<sub>(A,B)</sub>**: 2xG1/2 or 2xM22x1,5 - 15 mm [.59 in] depth  
**T** : G1/4 or M14x1,5 - 12 mm [.47 in] depth (plugged)

**PERMISSIBLE SHAFT LOADS**

**MPWN**

**MPW**

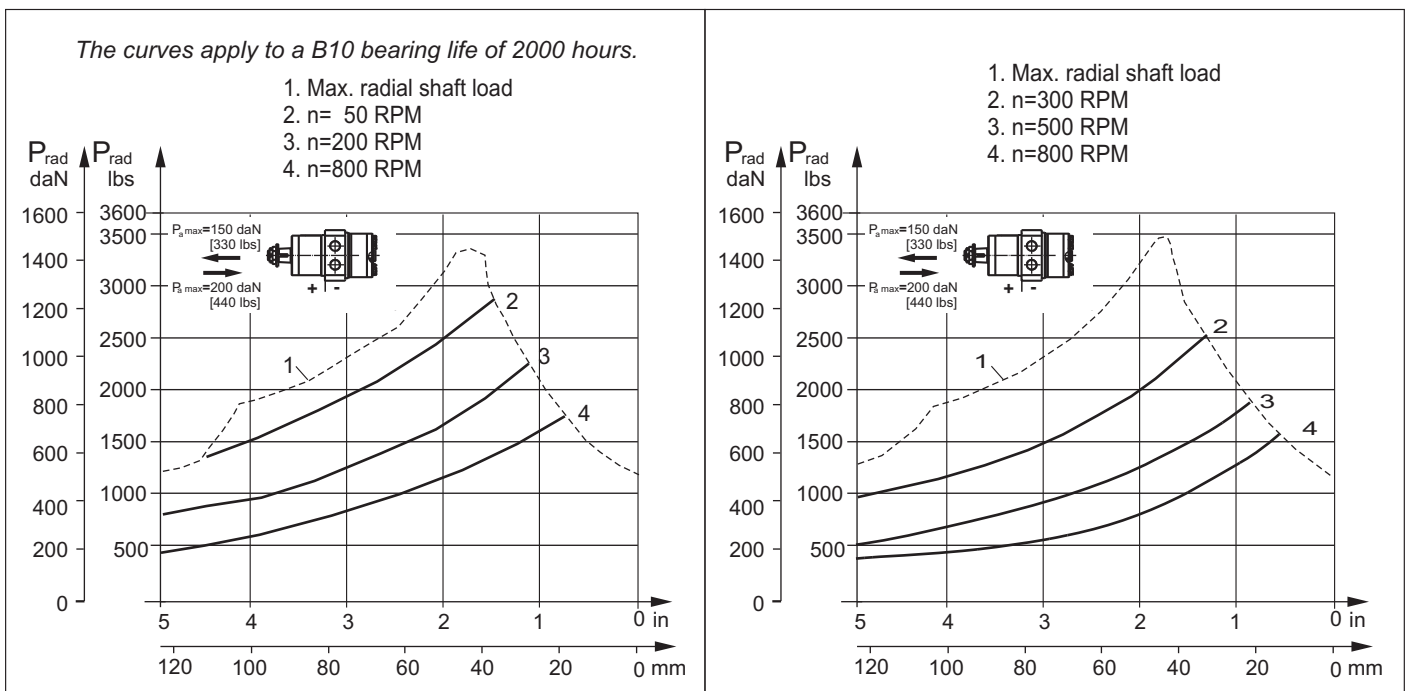

**SHAFT EXTENSIONS FOR MP AND MR MOTORS**

**C** -  $\varnothing 25$  straight, Parallel key A8x7x32 DIN 6885  
Max. Torque 34 daNm [3010 lb-in]

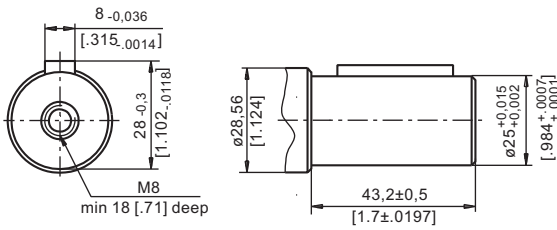

**CB** -  $\varnothing 32$  straight, Parallel key A10x8x45 DIN 6885  
Max. Torque 77 daNm [6815 lb-in]

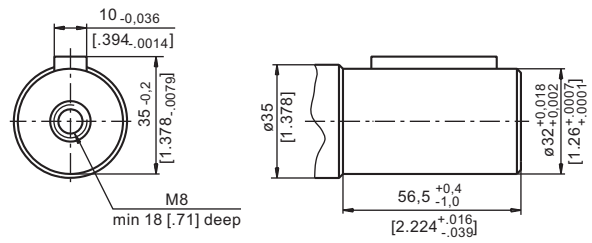

**CO** -  $\varnothing 1"$  straight, Parallel key  $\frac{1}{4} \times \frac{1}{4} \times 1 \frac{1}{4}$ " BS46  
Max. Torque 34 daNm [3010 lb-in]

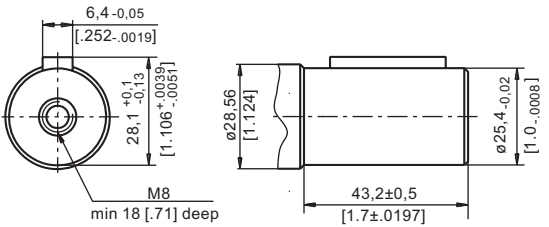

**SB** - splined A25x22xH10 DIN 5482  
Max. Torque 34 daNm [3010 lb-in]

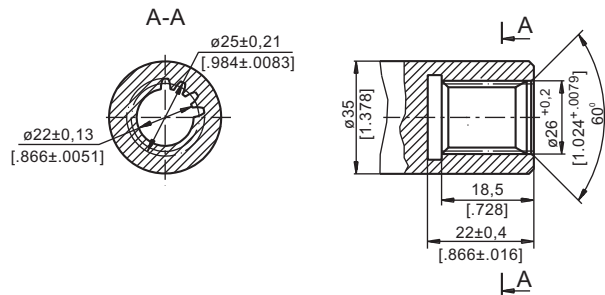

**SH** - splined, BS 2059 (SAE 6B)  
Max. Torque 40 daNm [3540 lb-in]

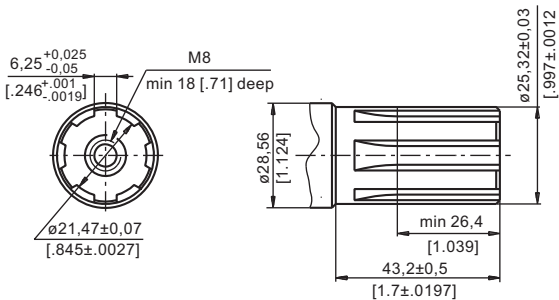

**KB** - tapered 1:10, Parallel key B6x6x20 DIN 6885  
Max. Torque 77 daNm [6815 lb-in]

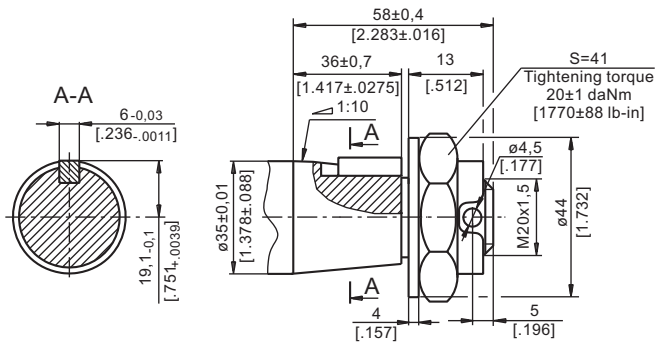

**K** - tapered 1:10, Parallel key B5x5x14 DIN 6885  
Max. Torque 40 daNm [3540 lb-in]

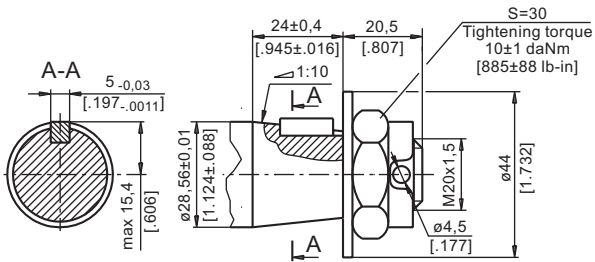

**OB** - tapered 1:8 SAEJ 501, Parallel key  $\frac{5}{16} \times \frac{5}{16} \times 1 \frac{1}{4}$ " BS46  
Max. Torque 77 daNm [6815 lb-in]

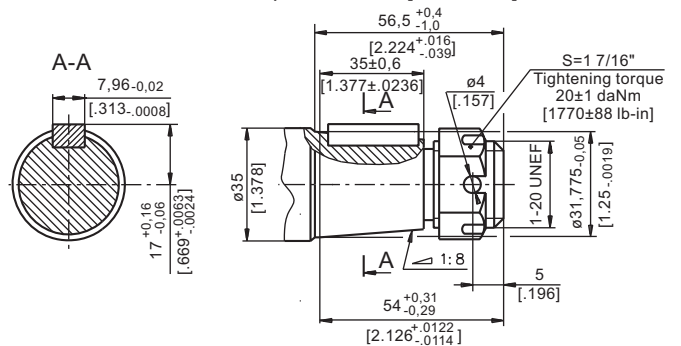

**SA** - splined, B25x22xH9 DIN 5482  
Max. Torque 40 daNm [3540 lb-in]

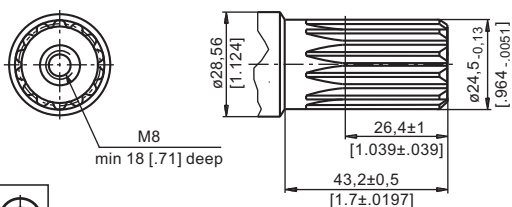

**HB** -  $\varnothing 1 \frac{1}{4}$ " splined 14T, ANSI B92.1-1976 Norm  
Max. Torque 77 daNm [6815 lb-in]

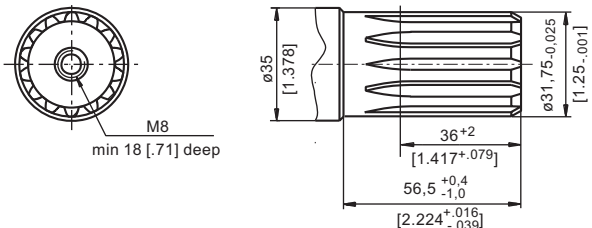

**PERMISSIBLE SHAFT LOADS FOR MP AND MR MOTORS**

The permissible radial shaft load  $P_{rad}$  depends on the speed  $n$ , RPM, distance  $L$  from the point of load to the mounting flange and shaft version.

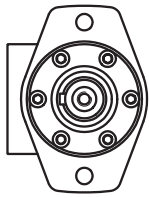
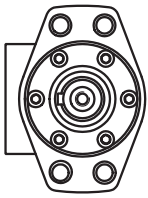
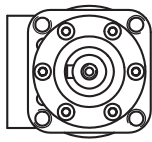
Mounting Flange			
Shaft Version	cylindrical - C, CO tapered - K, splined - SH	splined - HB cylindrical - CB	cylindrical - C, CO
Radial Shaft Load $P_{rad}$ , in mm	$\frac{800}{n} \times \frac{25000}{95+L}$ , daN*	$\frac{800}{n} \times \frac{18750}{95+L}$ , daN*	$\frac{800}{n} \times \frac{25000}{101+L}$ , daN*
Radial Shaft Load $P_{rad}$ , in inch	$\frac{800}{RPM} \times \frac{2215}{3.74+L}$ , lbs*	$\frac{800}{RPM} \times \frac{1660}{3.74+L}$ , lbs*	$\frac{800}{RPM} \times \frac{2215}{3.98+L}$ , lbs*

\*  $n < 200$  RPM; max  $P_{rad}$ =800 daN [1800 lbs]

$n \geq 200$  RPM;  $L < 55$  mm [2.2 in]

**MP AND MR**

Radial Shaft Load  $P_{rad}$  for C, CO Shaft Extensions by  $L=30$  mm [1.18 in] (24 mm [.94 in])

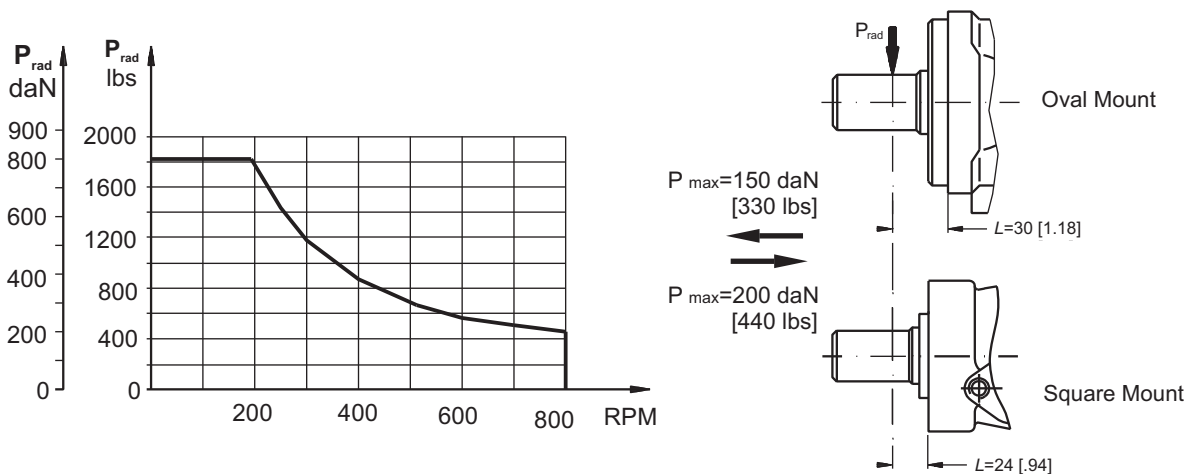

**MPN AND MRN**

The curves apply to a B10 bearing life of 2000 hours.

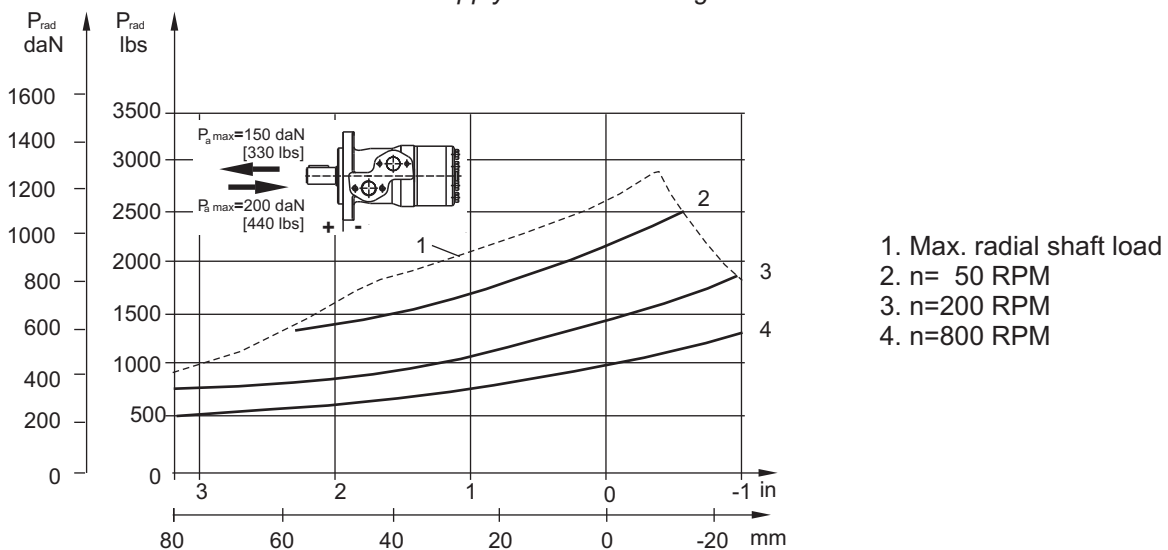

- 1. Max. radial shaft load
- 2.  $n = 50$  RPM
- 3.  $n = 200$  RPM
- 4.  $n = 800$  RPM

**MAX. PERMISSIBLE SHAFT SEAL PRESSURE FOR MP AND MR MOTORS**

**MP/MR...U1 motors with high pressure seal and without drain connection:**

The shaft seal pressure equals the average of input pressure and return pressure.

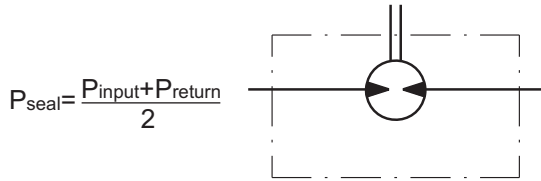

**MP/MR...U motors with high pressure seal and drain connection:**

The shaft seal pressure equals the pressure in the drain line.

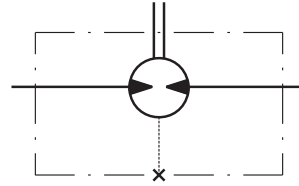

**MP/MR...1 motors with low pressure seal or standard shaft seal and without drain connection:**

The shaft seal pressure never exceeds the pressure in the return line.

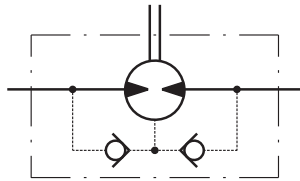

**MP/MR... motors with low pressure seal or standard shaft seal and with drain connection:**

The shaft seal pressure equals the pressure in the drain line.

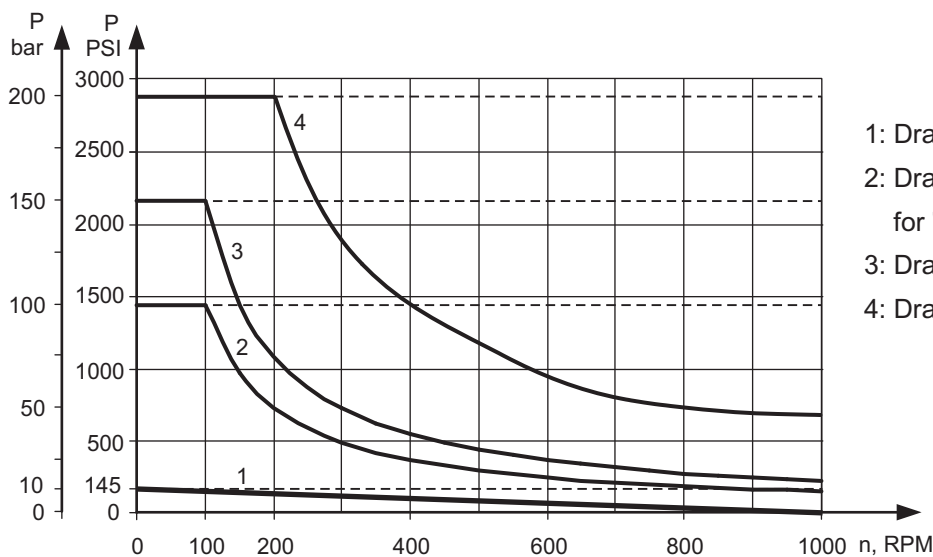
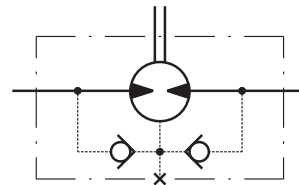

- 1: Drawing for Low Pressure Seal
- 2: Drawing for Standard Shaft Seal for "...B" shafts
- 3: Drawing for Standard Shaft Seal ("D" Seal)
- 4: Drawing for High Pressure Seal ("U" Seal)

— - continuous operations  
- - - - - intermittent operations

## ORDER CODE

	1	2	3	4	5	6	7	8	9	10
<b>M P</b>										

**Pos.1 - Mounting Flange**

- omit - Oval mount, two holes
- F** - Oval mount, four holes
- Q** - Square mount, four bolts
- W** - Wheel mount

**Pos.2 - Option (needle bearings)**

- omit - none
- N** - with needle bearings

**Pos.3 - Port type**

- omit - Side ports
- E** - Rear ports

**Pos.4 - Displacement code**

- 25\*** - 25,0 cm<sup>3</sup>/rev [ 1.52 in<sup>3</sup>/rev]
- 32\*** - 32,0 cm<sup>3</sup>/rev [ 1.95 in<sup>3</sup>/rev]
- 40\*** - 40,0 cm<sup>3</sup>/rev [ 2.44 in<sup>3</sup>/rev]
- 50** - 49,5 cm<sup>3</sup>/rev [ 3.02 in<sup>3</sup>/rev]
- 80** - 79,2 cm<sup>3</sup>/rev [ 4.83 in<sup>3</sup>/rev]
- 100** - 99,0 cm<sup>3</sup>/rev [ 6.04 in<sup>3</sup>/rev]
- 125** - 123,8 cm<sup>3</sup>/rev [ 7.55 in<sup>3</sup>/rev]
- 160** - 158,4 cm<sup>3</sup>/rev [ 9.66 in<sup>3</sup>/rev]
- 200** - 198,0 cm<sup>3</sup>/rev [12.10 in<sup>3</sup>/rev]
- 250** - 247,5 cm<sup>3</sup>/rev [15.10 in<sup>3</sup>/rev]
- 315** - 316,8 cm<sup>3</sup>/rev [19.30 in<sup>3</sup>/rev]
- 400** - 396,0 cm<sup>3</sup>/rev [24.16 in<sup>3</sup>/rev]
- 500** - 495,0 cm<sup>3</sup>/rev [30.20 in<sup>3</sup>/rev]
- 630** - 623,6 cm<sup>3</sup>/rev [38.05 in<sup>3</sup>/rev]

**Pos. 5 - Shaft Extensions\*\***(see page 28)

- C** - ø25 straight, Parallel key A8x7x32 DIN6885
- VC** - ø25 straight, Parallel key A8x7x32 DIN6885 with corrosion resistant bushing
- CO** - ø1" straight, Parallel key ¼"x¼"x1¼" BS46
- VCO** - ø1" straight, Parallel key ¼"x¼"x1¼" BS46 with corrosion resistant bushing
- SH** - ø25,32 splined BS 2059 (SAE 6B)
- VSH** - ø25,32 splined BS 2059 (SAE 6B) with corrosion resistant bushing
- K** - ø28,56 tapered 1:10, Parallel key B5x5x14 DIN6885
- SA** - ø24,5 splined B 25x22 DIN 5482
- VSA** - ø24,5 splined B 25x22 DIN 5482 with corrosion resistant bushing
- CB** - ø32 straight, Parallel key A10x8x45 DIN6885
- KB** - ø35 tapered 1:10, Parallel key B6x6x20 DIN6885
- SB** - splined A 25x22 DIN 5482
- OB** - ø1¼" tapered 1:8, Parallel key 5/16"x5/16"x1¼" BS46
- HB** - ø1¼" splined 14T ANSI B92.1 - 1976

**Pos. 6 - Shaft Seal Version** (see page 30)

- omit - Low pressure shaft seal or Standard shaft seal for "...B" shaft
- D** - Standard shaft seal
- U** - High pressure shaft seal (without check valves)

**Pos. 7 - Drain Port**

- omit - with drain port
- 1** - without drain port

**Pos. 8 - Ports**

- omit - BSPP (ISO 228)
- M** - Metric (ISO 262)

**Pos. 9 - Special Features** (see page 119)

**Pos.10 - Design Series**

- omit - Factory specified

**NOTES:**

- \* Not with Low Pressure Seal
- \*\* The permissible output torque for shafts must not be exceeded!

The following combinations are not allowed: - **Q** flange with "...B" shafts;  
 - **W** flange with "...B" shafts or **E** rear ports;  
 - **N** option with "...B" shafts, Low Pressure Seal or **U** option;  
 - "...B" shafts with **D** and **U** shaft seals.

Displacement codes 25, 32,40 and 50 are not allowed with **B, K, L, R** shafts!

The hydraulic motors are mangano-phosphatized as standard.

# HYDRAULIC MOTORS MR



## APPLICATION

- » Conveyors
- » Feeding mechanism of robots and manipulators
- » Metal working machines
- » Textile machines
- » Agricultural machines
- » Food industries
- » Grass cutting machinery etc.

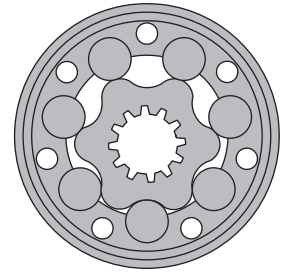

## CONTENTS

Specification data .....	29÷30
Function diagrams .....	31÷39
Dimensions and mounting .....	40÷41
Shaft extensions .....	28
Permissible shaft loads .....	29
Permissible shaft Seal Pressure ...	30
Order code .....	42

## OPTIONS

- » Model - Spool valve, roll-gerotor
- » Flange mount
- » Motor with needle bearing
- » Side and rear ports
- » Shafts - straight, splined and tapered
- » Shaft seal for high and low pressure
- » Metric and BSPP ports
- » Speed sensing
- » Other special features

## GENERAL

<b>Max. Displacement,</b> cm <sup>3</sup> /rev [in <sup>3</sup> /rev]	397 [24.4]
<b>Max. Speed,</b> [RPM]	970
<b>Max. Torque,</b> daNm [lb-in]	cont.: 61 [5400] int.: 69 [6100]
<b>Max. Output,</b> kW [HP]	15 [20.1]
<b>Max. Pressure Drop,</b> bar [PSI]	cont.: 175 [2540] int.: 200 [2900]
<b>Max. Oil Flow,</b> lpm [GPM]	75 [20]
<b>Min. Speed,</b> [RPM]	10
<b>Pressure fluid</b>	Mineral based- HLP(DIN 51524) or HM(ISO 6743/4)
<b>Temperature range,</b> °C [°F]	-40÷140 [-40÷284]
<b>Optimal Viscosity range,</b> mm <sup>2</sup> /s [SUS]	20÷75 [98÷347]
<b>Filtration</b>	ISO code 20/16 (Min. recommended fluid filtration of 25 microns)

### Oil flow in drain line

Pressure drop bar [PSI]	Viscosity mm <sup>2</sup> /s [SUS]	Oil flow in drain line lpm [GPM]
100 [1450]	20 [98]	2,5 [.660]
	35 [164]	1,8 [.476]
140 [2030]	20 [98]	3,5 [.925]
	35 [164]	2,8 [.740]

### Pressure Losses

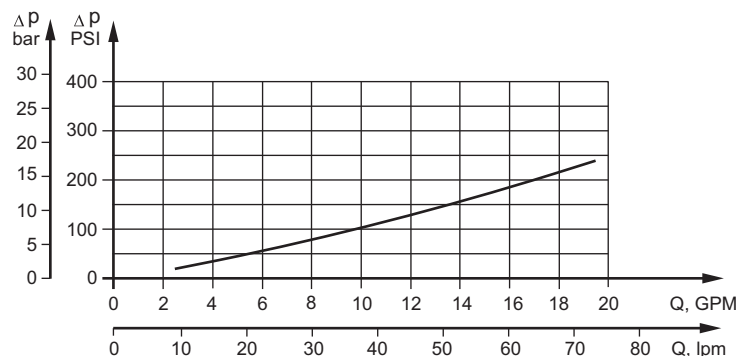

## SPECIFICATION DATA

Specification Data for MR... motors with **C, CO, SH, K** and **SA** shafts.  
( $\varnothing 28,56$  sealing diameter)

Type		MR 50	MR 80	MR 100	MR 125	MR 160	MR 200	MR 250	MR 315	MR 400
Displacement, cm <sup>3</sup> /rev [in <sup>3</sup> /rev]		51,5 [3.14]	80,3 [4.90]	99,8 [6.09]	125,7 [7.67]	159,6 [9.74]	199,8 [12.19]	250,1 [15.26]	315,7 [19.26]	397 [24.4]
	Max. Speed, [RPM]									
	Cont.	775	750	600	475	375	300	240	190	150
	Int.*	970	940	750	600	470	375	300	240	190
Max. Torque daNm [in-lb]	Cont.	10 [900]	20 [1770]	24 [2125]	30 [2655]	39 [3450]	38,5[3410]	39 [3450]	36 [3185]	38 [3360]
	Int.*	13 [1150]	22 [1947]	28 [2480]	34 [3010]	43 [3805]	46 [4070]	47 [4160]	47 [4160]	47 [4160]
	Peak**	17 [1505]	27 [2390]	32 [2832]	37 [3275]	46 [4070]	56 [4960]	60 [5310]	61 [5400]	61 [5400]
Max. Output kW [HP]	Cont.	7 [9.5]	12,5 [17]	13 [17.4]	12,5[16.8]	11,5[15.4]	9 [12]	8 [10.7]	5 [6.7]	4,8 [6.4]
	Int.*	8,5 [11.9]	15 [20.1]	15 [20.1]	14,5[19.5]	14 [18.8]	12 [16.1]	9,5 [12.7]	8 [10.7]	6,8 [9.1]
Max. Pressure Drop bar [PSI]	Cont.	140[2030]	175[2540]	175[2540]	175[2540]	175[2540]	140[2030]	110[1600]	85 [1230]	65 [940]
	Int.*	175[2540]	200[2900]	200[2900]	200[2900]	200[2900]	175[2540]	140[2030]	115[1670]	90 [1300]
	Peak**	225[3260]	225[3260]	225[3260]	225[3260]	225[3260]	225[3260]	200[2900]	150[2175]	115[1670]
Max. Oil Flow lpm [GPM]	Cont.	40 [10.5]	60 [15.8]	60 [15.8]	60 [15.8]	60 [15.8]	60 [15.8]	60 [15.8]	60 [15.8]	60 [15.8]
	Int.*	50 [13.2]	75 [19.8]	75 [19.8]	75 [19.8]	75 [19.8]	75 [19.8]	75 [19.8]	75 [19.8]	75 [19.8]
Max. Inlet Pressure bar [PSI]	Cont.	175[2540]	175[2540]	175[2540]	175[2540]	175[2540]	175[2540]	175[2540]	175[2540]	175[2540]
	Int.*	200[2900]	200[2900]	200[2900]	200[2900]	200[2900]	200[2900]	200[2900]	200[2900]	200[2900]
	Peak**	225[3260]	225[3260]	225[3260]	225[3260]	225[3260]	225[3260]	225[3260]	225[3260]	225[3260]
Max. Return Pres- sure with Drain Line bar [PSI]	Cont.	175[2540]	175[2540]	175[2540]	175[2540]	175[2540]	175[2540]	175[2540]	175[2540]	175[2540]
	Int.*	200[2900]	200[2900]	200[2900]	200[2900]	200[2900]	200[2900]	200[2900]	200[2900]	200[2900]
	Peak**	225[3260]	225[3260]	225[3260]	225[3260]	225[3260]	225[3260]	225[3260]	225[3260]	225[3260]
Max. Starting Pressure with Unloaded Shaft, bar [PSI]		10 [145]	10 [145]	10 [145]	9 [130]	7 [102]	5 [73]	4 [58]	3 [44]	3 [44]
	Min. Starting Torque daNm [in-lb]									
	At max.press. drop Cont.	8 [710]	15 [1330]	20 [1770]	25 [2215]	32 [2832]	33 [2920]	31 [2740]	31,5[2875]	31,5[2875]
	At max.press. drop Int.*	10 [85]	17 [1505]	23 [2035]	28 [2480]	37 [3275]	40 [3540]	48 [4250]	58 [5220]	50 [4425]
Min. Speed***, [RPM]		10	10	10	10	10	10	10	10	10
Weight, kg [lb]	MR(F)	6,8 [15]	6,9 [15,2]	7,2 [15.9]	7,3 [16.1]	7,5 [15.2]	8 [17.6]	8,4 [18.5]	9,1 [20]	9,8 [21.6]
	For rear ports: +0,650 [1.433] MRQ(N)	6,2 [13.7]	6,3 [13.9]	6,6 [14.6]	6,8 [15]	7,2 [14.7]	7,6 [15.4]	7,8 [17.2]	8,6 [19]	9,3 [20.5]

\* Intermittent operation: the permissible values may occur for max. 10% of every minute.

\*\* Peak load: the permissible values may occur for max. 1% of every minute.

\*\*\* For speeds lower than given, consult factory or your regional manager.

- Intermittent speed and intermittent pressure must not occur simultaneously.
- Recommended filtration is per ISO cleanliness code 20/16. A nominal filtration of 25 micron or better.
- Recommend using a premium quality, anti-wear type mineral based hydraulic oil HLP(DIN51524) or HM (ISO 6743/4).  
If using synthetic fluids consult the factory for alternative seal materials.
- Recommended minimum oil viscosity 13 mm<sup>2</sup>/s [70 SUS] at 50°C [122°F].
- Recommended maximum system operating temperature is 82°C [180°F].
- To assure optimum motor life fill with fluid prior to loading and run at moderate load and speed for 10-15 minutes.

## SPECIFICATION DATA (continued)

Specification Data for MR... motors with CB, KB, OB and HB shafts.  
(ø35 sealing diameter)

Type		MR 50	MR 80	MR 100	MR 125	MR 160	MR 200	MR 250	MR 315	MR 400
Displacement, cm <sup>3</sup> /rev [in <sup>3</sup> /rev ]		51,5 [3.14]	80,3 [4.90]	99,8 [6.09]	125,7 [7.67]	159,6 [9.74]	199,8 [12.19]	250,1 [15.26]	315,7 [19.26]	397 [24.4]
	Max. Speed, [RPM]									
	Cont.	775	750	600	475	375	300	240	190	150
	Int.*	970	940	750	600	470	375	300	240	190
Max. Torque daNm [in-lb]	Cont.	10 [900]	20 [1770]	24 [2125]	30 [2655]	39 [3450]	45 [4000]	54 [4780]	55 [4870]	61 [5400]
	Int.*	13 [1150]	22 [1947]	28 [2480]	34 [3010]	43 [3805]	50 [4425]	61 [5400]	69 [6110]	69 [6110]
	Peak**	17 [1505]	27 [2390]	32 [2832]	37 [3275]	46 [4070]	56 [4960]	71 [6280]	84 [7435]	87 [7700]
Max. Output kW [HP]	Cont.	7 [9.5]	12,5 [17]	13 [17.4]	12,5[16.8]	11,5[15.4]	11 [14.8]	10 [13.4]	9 [12]	7,8 [10.5]
	Int.*	8,5 [11.9]	15 [20.1]	15 [20.1]	14,5[19.5]	14 [18.8]	13 [17.4]	12 [16.1]	10 [13.4]	10,6[14.2]
Max. Pressure Drop bar [PSI]	Cont.	140[2030]	175[2540]	175[2540]	175[2540]	175[2540]	175[2540]	175[2540]	135[1960]	110[1600]
	Int.*	175[2540]	200[2900]	200[2900]	200[2900]	200[2900]	200[2900]	200[2900]	175[2540]	140[2030]
	Peak**	225[3260]	225[3260]	225[3260]	225[3260]	225[3260]	225[3260]	225[3260]	210[3045]	175[2540]
Max. Oil Flow lpm [GPM]	Cont.	40 [10.5]	60 [15.8]	60 [15.8]	60 [15.8]	60 [15.8]	60 [15.8]	60 [15.8]	60 [15.8]	60 [15.8]
	Int.*	50 [13.2]	75 [19.8]	75 [19.8]	75 [19.8]	75 [19.8]	75 [19.8]	75 [19.8]	75 [19.8]	75 [19.8]
Max. Inlet Pressure bar [PSI]	Cont.	175[2540]	175[2540]	175[2540]	175[2540]	175[2540]	175[2540]	175[2540]	175[2540]	175[2540]
	Int.*	200[2900]	200[2900]	200[2900]	200[2900]	200[2900]	200[2900]	200[2900]	200[2900]	200[2900]
	Peak**	225[3260]	225[3260]	225[3260]	225[3260]	225[3260]	225[3260]	225[3260]	225[3260]	225[3260]
Max. Return Pres- sure with Drain Line bar [PSI]	Cont.	175[2540]	175[2540]	175[2540]	175[2540]	175[2540]	175[2540]	175[2540]	175[2540]	175[2540]
	Int.*	200[2900]	200[2900]	200[2900]	200[2900]	200[2900]	200[2900]	200[2900]	200[2900]	200[2900]
	Peak**	225[3260]	225[3260]	225[3260]	225[3260]	225[3260]	225[3260]	225[3260]	225[3260]	225[3260]
Max. Starting Pressure with Unloaded Shaft, bar [PSI]		10 [145]	10 [145]	10 [145]	9 [130]	7 [102]	5 [73]	4 [58]	3 [44]	3 [44]
Min. Starting Torque daNm [in-lb]	At max.press. drop Cont.	8 [710]	15 [1330]	20 [1770]	25 [2215]	32 [2832]	41 [3630]	50 [4425]	50 [4425]	50 [4425]
	At max.press. drop Int.*	10 [885]	17 [1505]	23 [2035]	28 [2480]	37 [3275]	46 [4070]	55 [4870]	66 [5840]	61 [5400]
Min. Speed***, [RPM]		10	10	10	10	10	10	10	10	10
Weight, kg [lb]										
For rear ports: +0,650 [1.433]		6,9 [15,2]	7 [15,4]	7,3 [16.1]	7,4 [16.3]	7,6 [15.4]	8,1 [18.9]	8,5 [18.7]	9,2 [20.3]	9,9 [21.8]

\* Intermittent operation: the permissible values may occur for max. 10% of every minute.

\*\* Peak load: the permissible values may occur for max. 1% of every minute.

\*\*\* For speeds lower than given, consult factory or your regional manager.

- Intermittent speed and intermittent pressure must not occur simultaneously.
- Recommended filtration is per ISO cleanliness code 20/16. A nominal filtration of 25 micron or better.
- Recommend using a premium quality, anti-wear type mineral based hydraulic oil HLP(DIN51524) or HM ( ISO 6743/4).  
If using synthetic fluids consult the factory for alternative seal materials.
- Recommended minimum oil viscosity 13 mm<sup>2</sup>/s [70 SUS] at 50°C [122°F].
- Recommended maximum system operating temperature is 82°C [180°F].
- To assure optimum motor life fill with fluid prior to loading and run at moderate load and speed for 10-15 minutes.

**FUNCTION DIAGRAMS**

**MR 50**

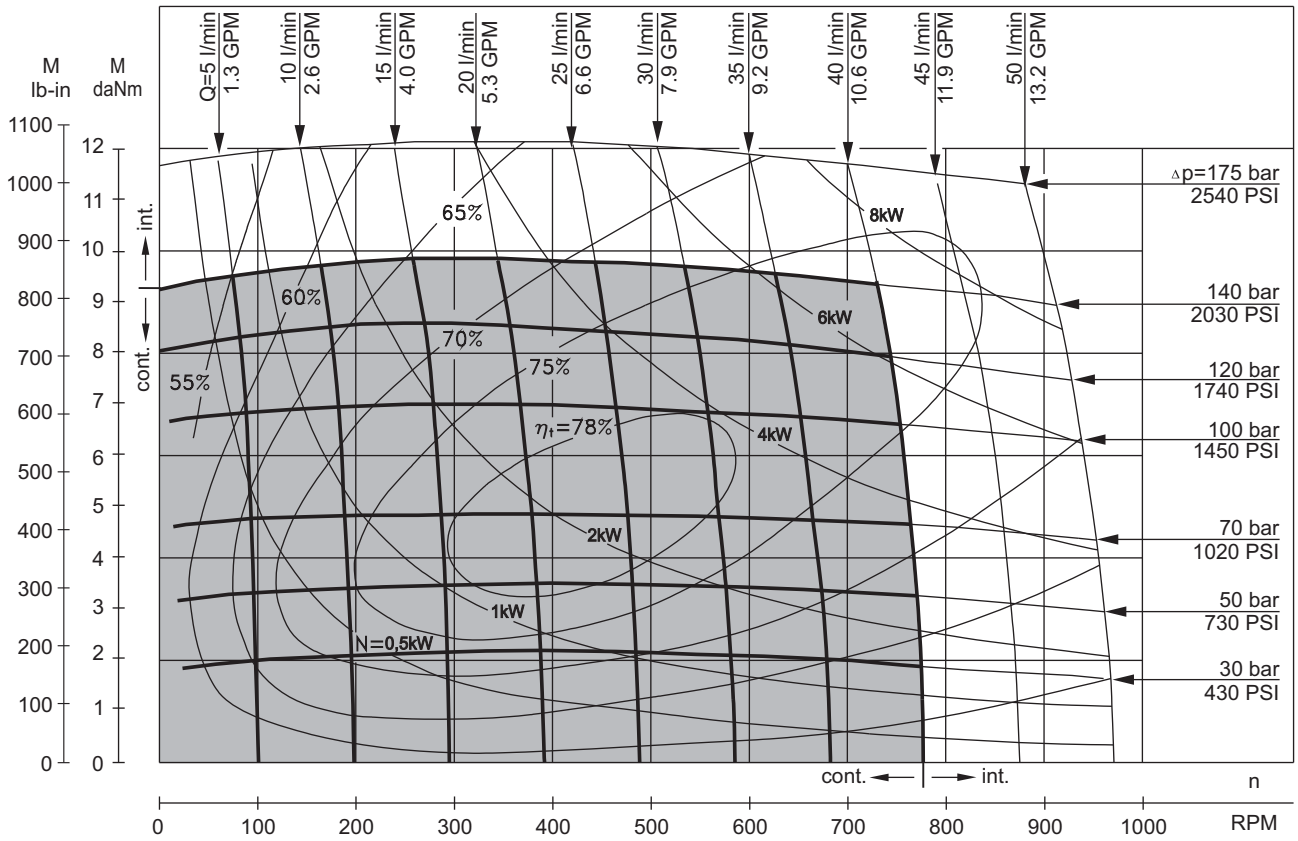

**MR 80**

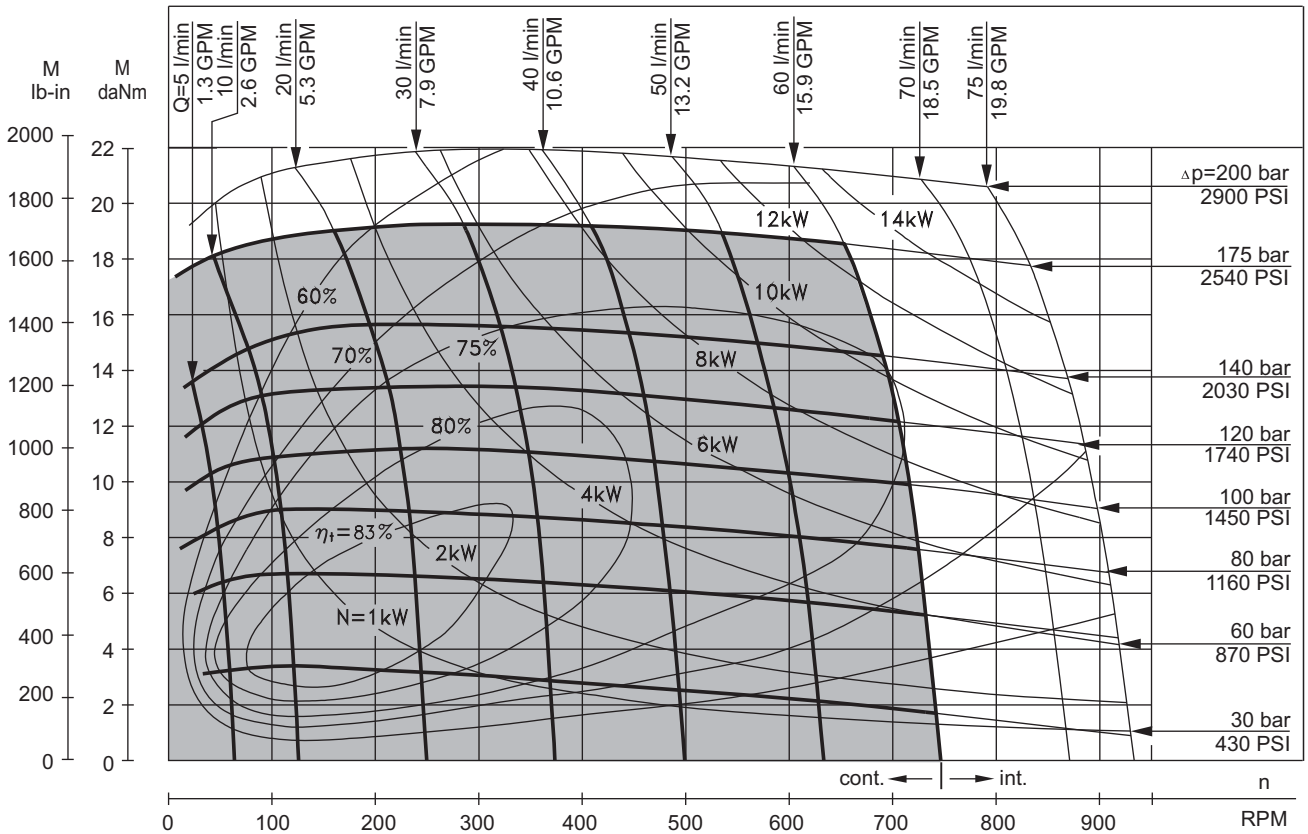

The function diagrams data is for average performance of randomly selected motors at back pressure  $5 \div 10$  bar [72.5  $\div$  145 PSI] and oil with viscosity of 32 mm<sup>2</sup>/s [150 SUS] at 50°C [122°F].

**FUNCTION DIAGRAMS**

**MR 100**

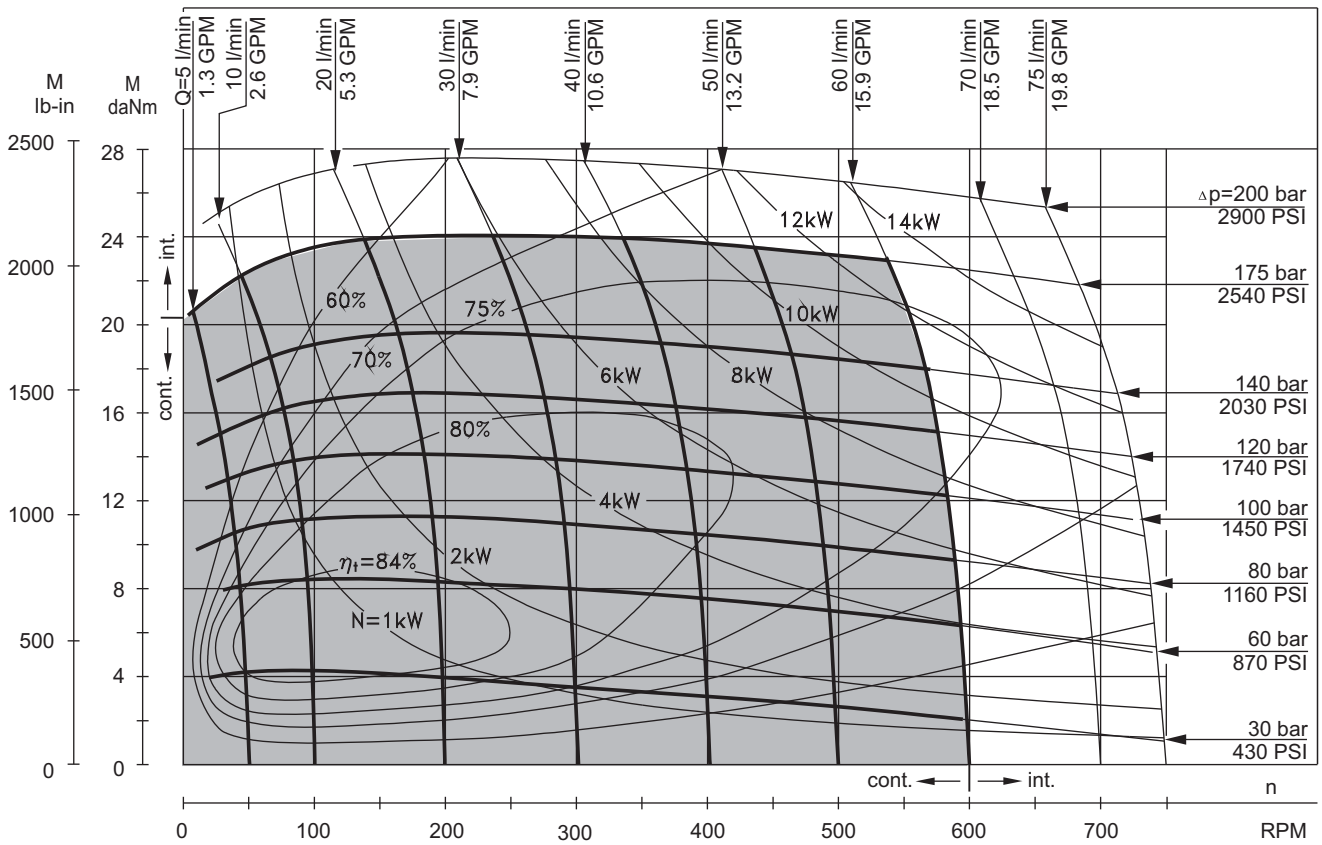

**MR 125**

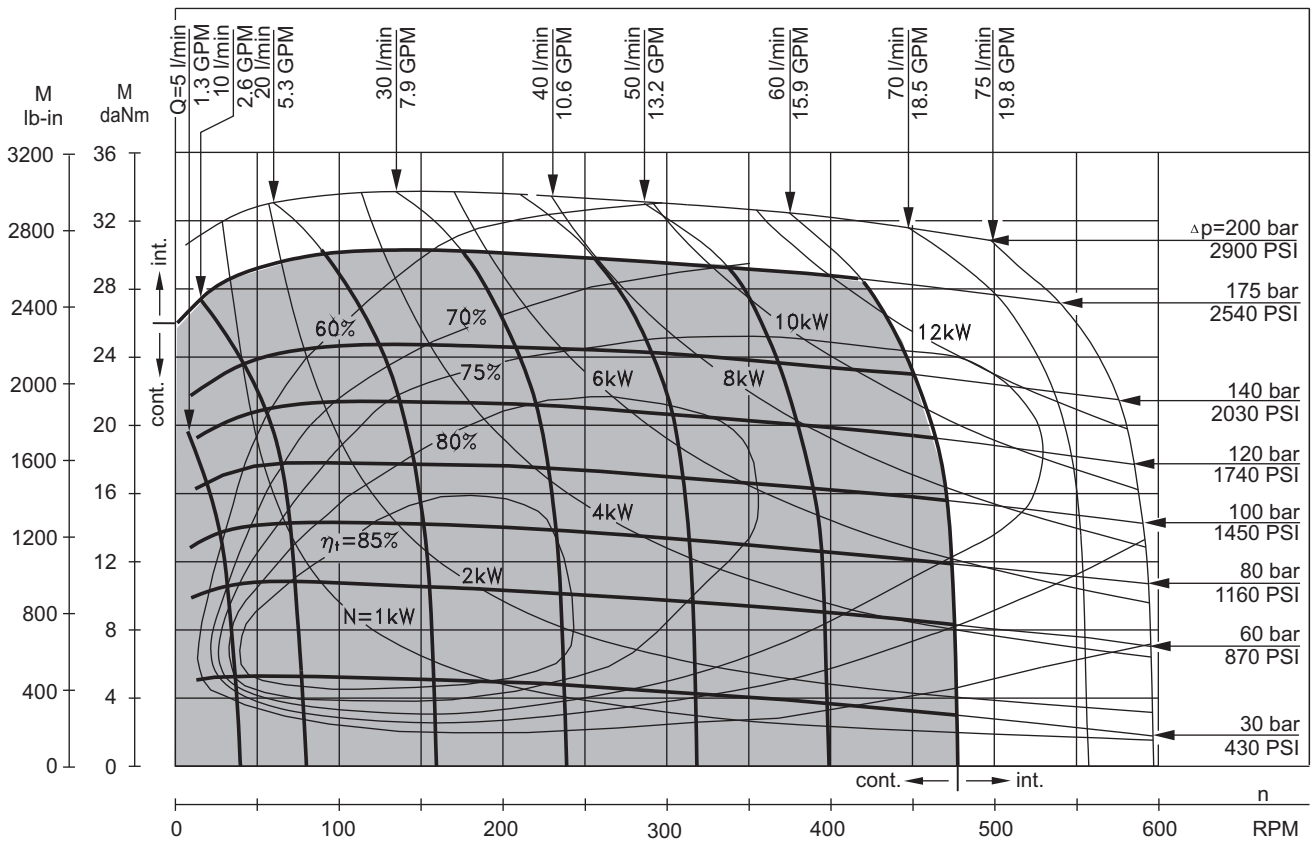

The function diagrams data is for average performance of randomly selected motors at back pressure  $5 \div 10$  bar [72.5  $\div$  145 PSI] and oil with viscosity of 32 mm<sup>2</sup>/s [150 SUS] at 50°C [122°F].

**FUNCTION DIAGRAMS**

**MR 160**

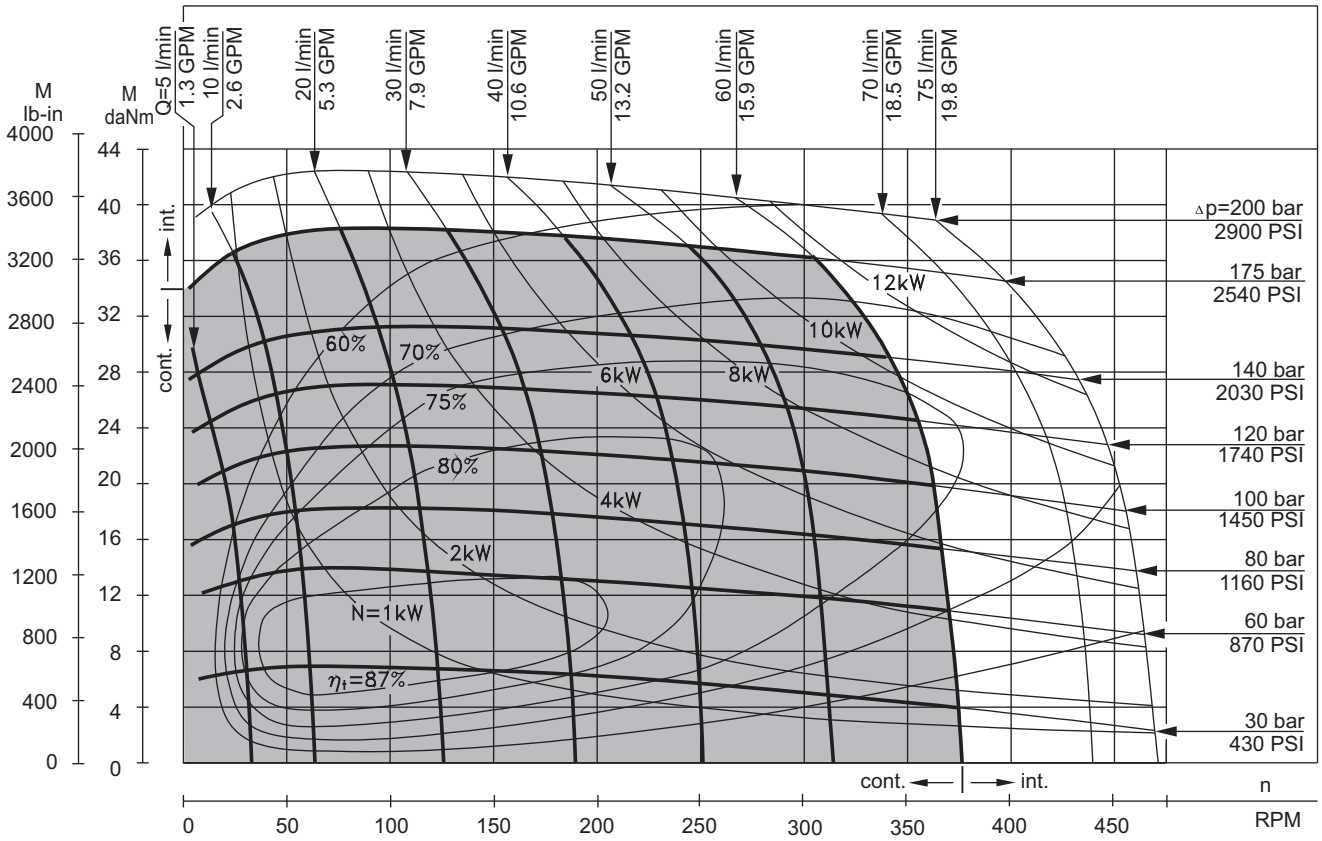

**MR 200**

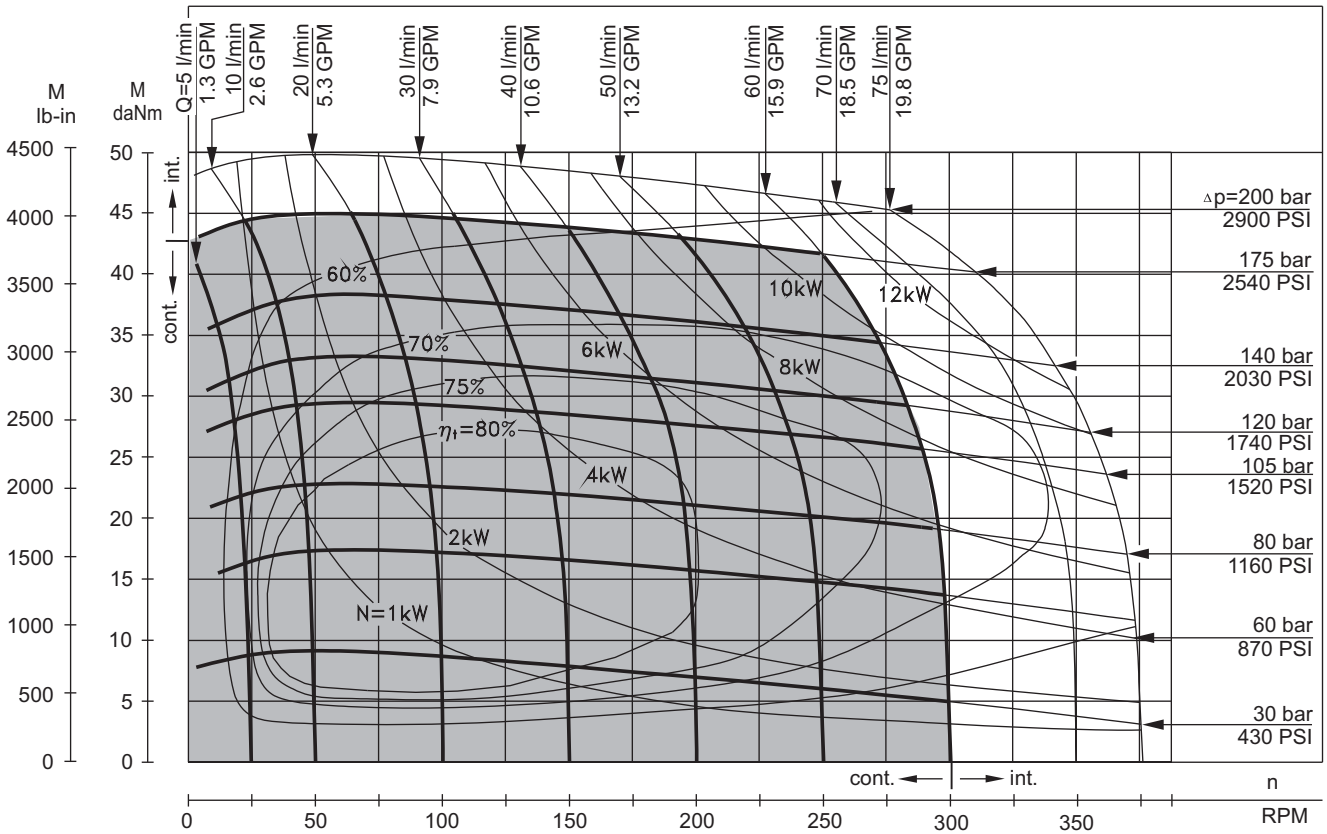

The function diagrams data is for average performance of randomly selected motors at back pressure 5÷10 bar [72.5÷145 PSI] and oil with viscosity of 32 mm<sup>2</sup>/s [150 SUS] at 50°C [122°F].

**FUNCTION DIAGRAMS**

**MR 250**

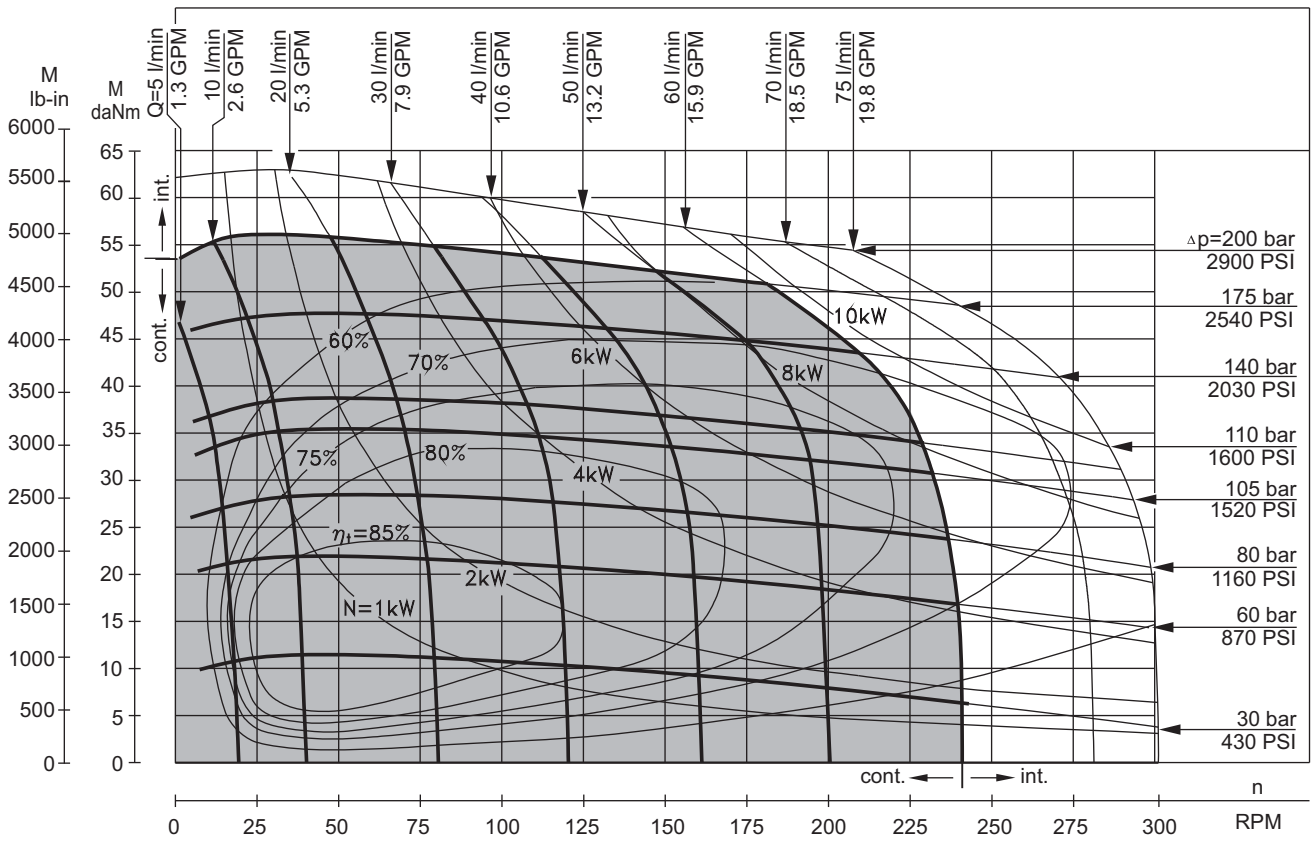

**MR 315**

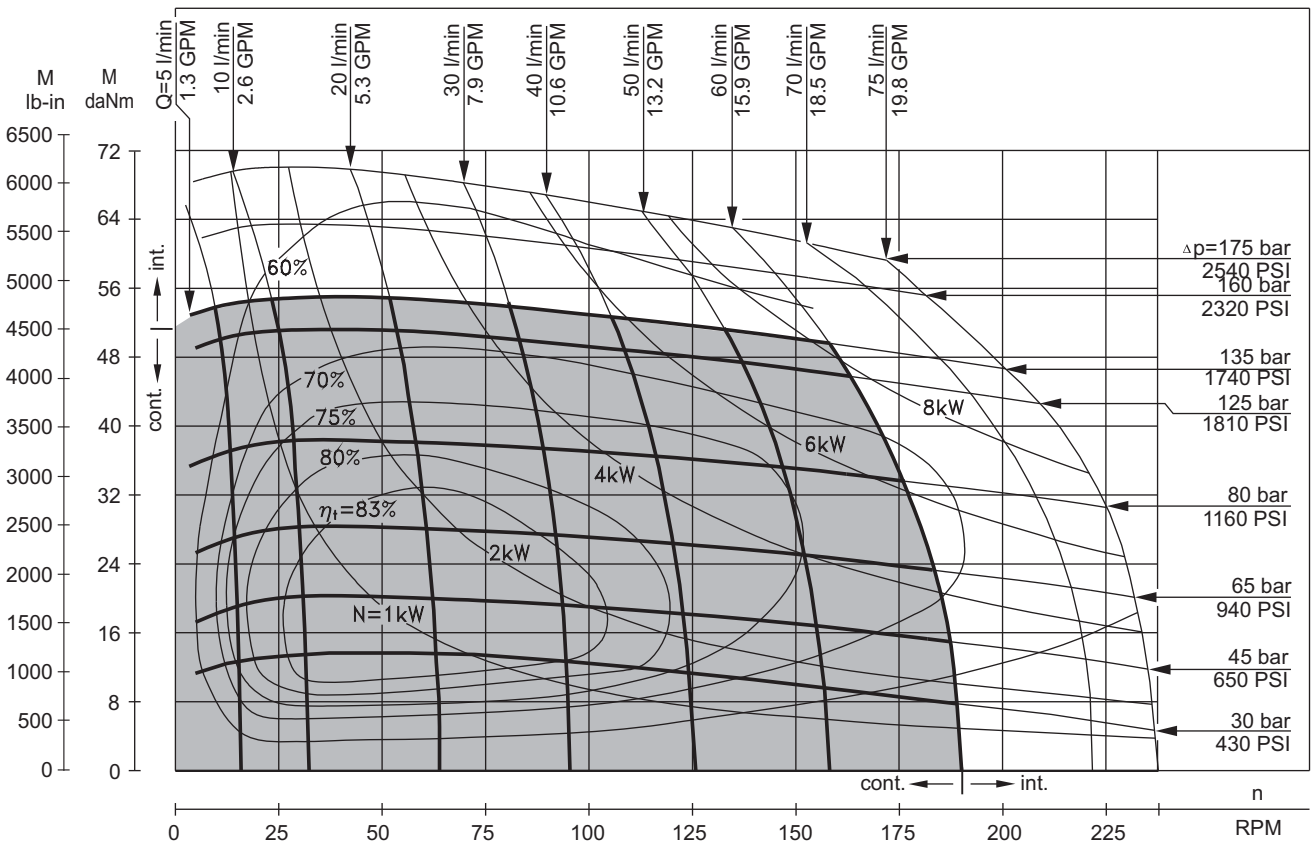

The function diagrams data is for average performance of randomly selected motors at back pressure  $5 \div 10$  bar [72.5  $\div$  145 PSI] and oil with viscosity of 32 mm<sup>2</sup>/s [150 SUS] at 50°C [122°F].

**FUNCTION DIAGRAMS**

**MR 400**

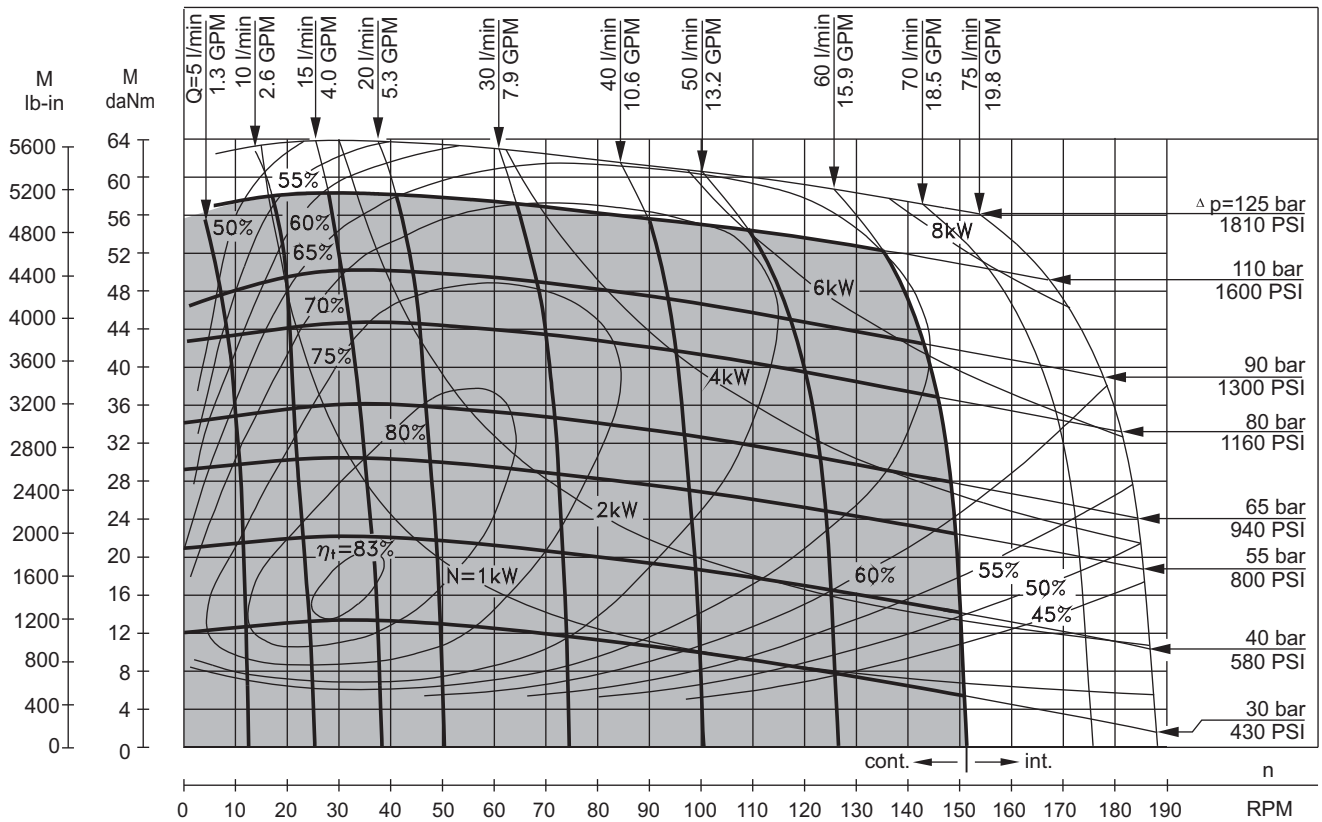

The function diagrams data is for average performance of randomly selected motors at back pressure  $5 \div 10$  bar [72.5  $\div$  145 PSI] and oil with viscosity of 32 mm<sup>2</sup>/s [150 SUS] at 50°C [122°F].

**DIMENSIONS AND MOUNTING DATA**

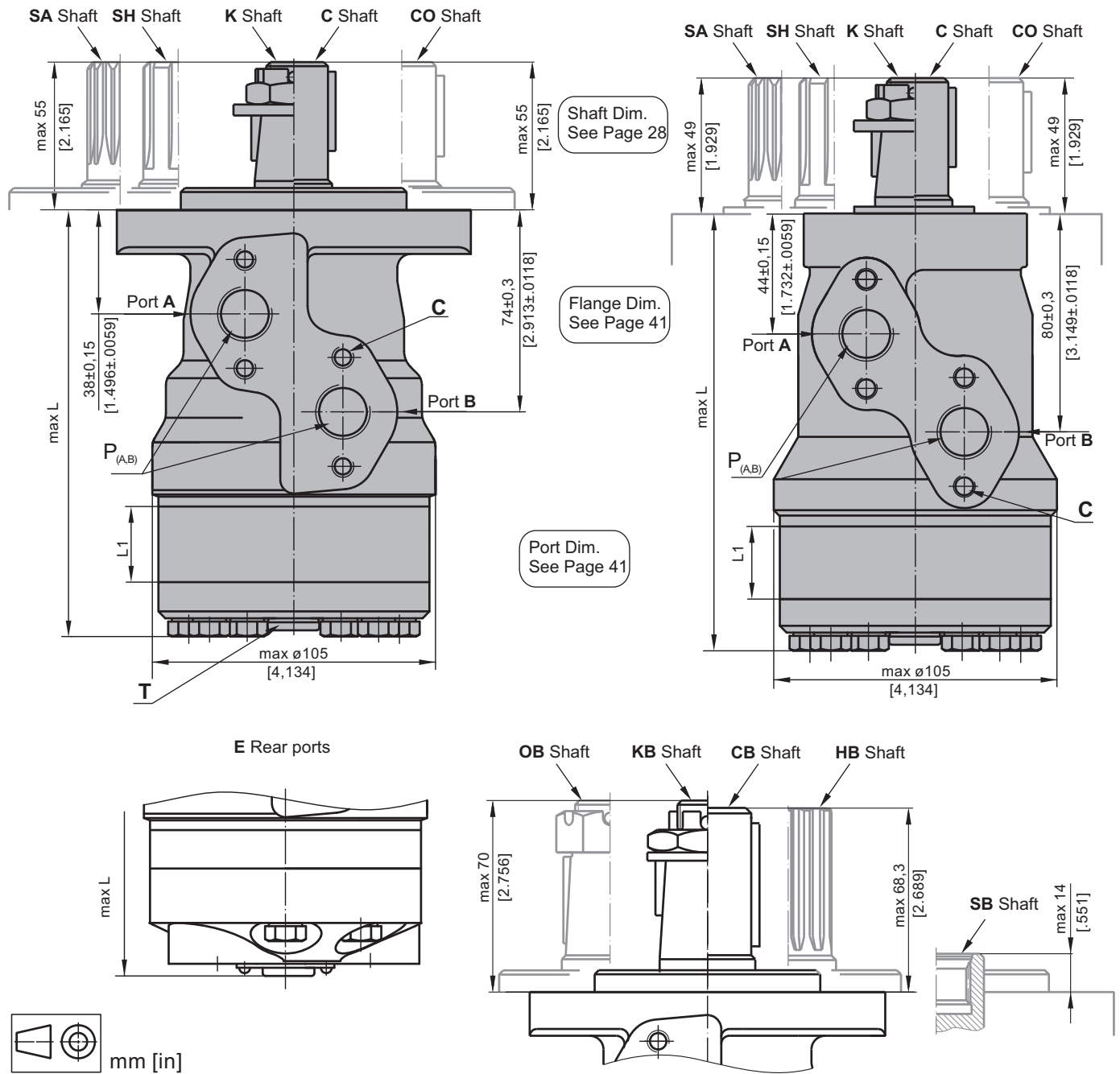

**C** : 4xM8 - 13 mm [.51 in] depth  
**P<sub>(A,B)</sub>** : 2xG1/2 or 2xM22x1,5 - 15 mm [.59 in] depth  
**T** : G1/4 or M14x1,5 - 12 mm [.47 in] depth (plugged)

**Standard Rotation**  
 Viewed from Shaft End  
 Port A Pressurized - **CW**  
 Port B Pressurized - **CCW**

**Reverse Rotation**  
 Viewed from Shaft End  
 Port A Pressurized - **CCW**  
 Port B Pressurized - **CW**

Type	L, mm [in]	Type	L, mm [in]	Type	L, mm [in]	Type	L, mm [in]	L <sub>1</sub> , mm [in]
MR(F) 50	138,0 [5.43]	MRQ 50	143,5 [5.65]	MR(F)E 50	157,5 [6.20]	MRQE 50	163,5 [6.44]	9,0 [.35]
MR(F) 80	143,0 [5.63]	MRQ 80	148,5 [5.85]	MR(F)E 80	162,5 [6.40]	MRQE 80	168,5 [6.63]	14,0 [.55]
MR(F) 100	146,0 [5.75]	MRQ 100	152,0 [5.98]	MR(F)E 100	165,5 [6.52]	MRQE 100	171,5 [6.75]	17,4 [.69]
MR(F) 125	150,5 [5.93]	MRQ 125	156,5 [6.16]	MR(F)E 125	170,0 [6.69]	MRQE 125	176,0 [6.93]	21,8 [.86]
MR(F) 160	156,5 [6.16]	MRQ 160	162,5 [6.40]	MR(F)E 160	176,0 [6.93]	MRQE 160	182,0 [7.17]	27,8 [1.09]
MR(F) 200	163,5 [6.44]	MRQ 200	169,5 [6.67]	MR(F)E 200	183,0 [7.20]	MRQE 200	189,0 [7.44]	34,8 [1.37]
MR(F) 250	172,0 [6.77]	MRQ 250	179,0 [7.05]	MR(F)E 250	192,0 [7.56]	MRQE 250	198,0 [7.80]	43,5 [1.71]
MR(F) 315	183,0 [7.20]	MRQ 315	189,0 [7.44]	MR(F)E 315	204,0 [8.03]	MRQE 315	210,0 [8.27]	54,8 [2.16]
MR(F) 400	198,0 [7.80]	MRQ 400	204,0 [8.03]	MR(F)E 400	218,0 [8.58]	MRQE 400	224,0 [8.82]	69,4 [2.73]

**MOUNTING**

**Oval Mount (2 Holes)**

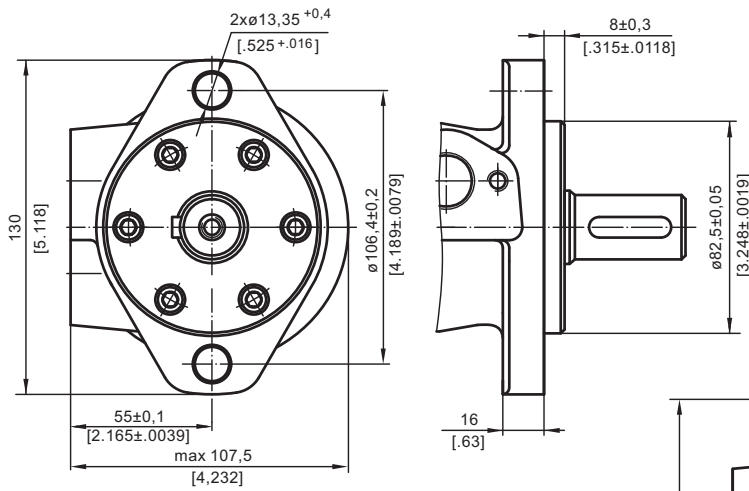

**F - Oval Mount (4 Holes)**

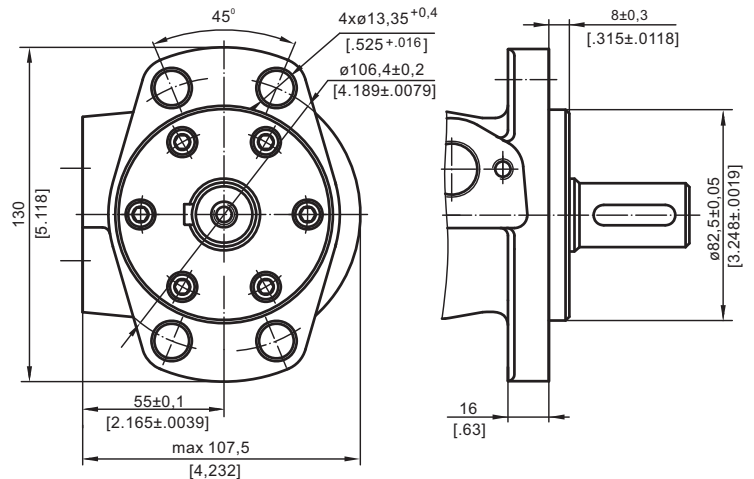

**Q - Square Mount (4 Bolts)**

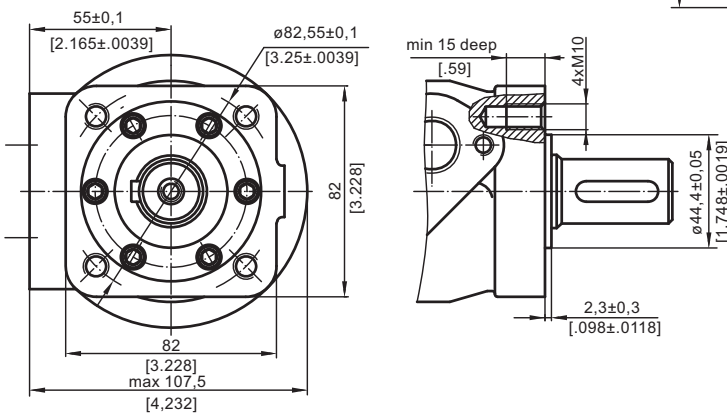

**PORTS**

**Side Ports**

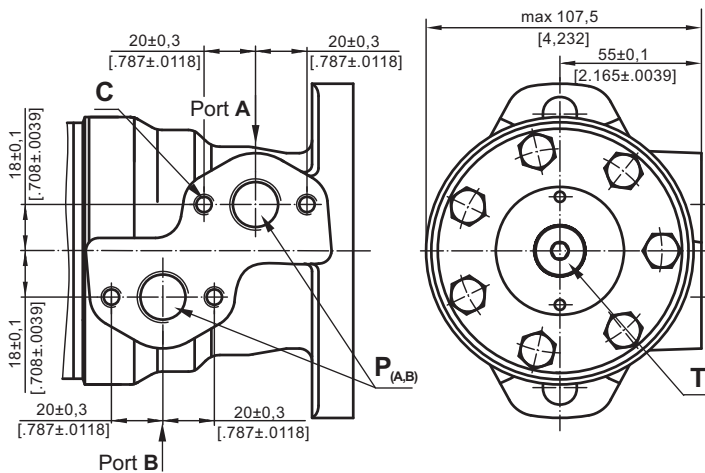

- C** : 4xM8 - 13 mm [.51 in] depth
- P<sub>(A,B)</sub>** : 2xG1/2 or 2xM22x1,5 - 15 mm [.59 in] depth
- T** : G1/4 or M14x1,5 - 12 mm [.47 in] depth (plugged)

**E Rear Ports**

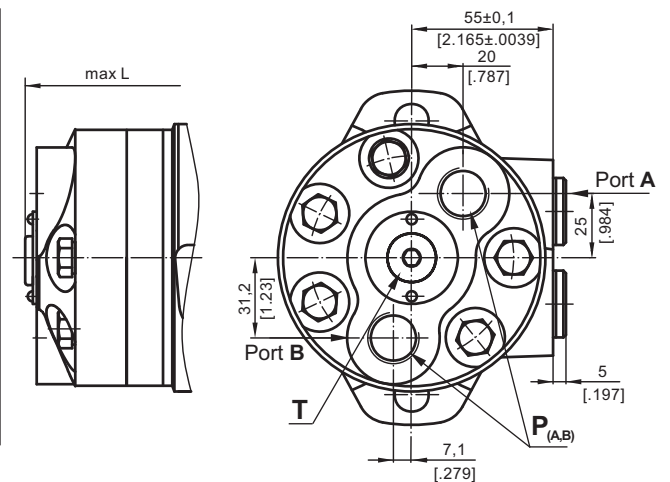

- Standard Rotation**  
Viewed from Shaft End  
Port A Pressurized - CW  
Port B Pressurized - CCW
- Reverse Rotation**  
Viewed from Shaft End  
Port A Pressurized - CCW  
Port B Pressurized - CW

**ORDER CODE**

	1	2	3	4	5	6	7	8	9	10
<b>M R</b>										

**Pos.1 - Mounting Flange**

- omit - Oval mount, two holes
- F** - Oval mount, four holes
- Q** - Square mount, four bolts

**Pos.2 - Option (needle bearings)**

- omit - none
- N** - with needle bearings

**Pos.3 - Port type**

- omit - Side ports
- E** - Rear ports

**Pos.4 - Displacement code**

- 50** - 51,5 cm<sup>3</sup>/rev [ 3.14 in<sup>3</sup>/rev]
- 80** - 80,3 cm<sup>3</sup>/rev [ 4.90 in<sup>3</sup>/rev]
- 100** - 99,8 cm<sup>3</sup>/rev [ 6.09 in<sup>3</sup>/rev]
- 125** - 125,7 cm<sup>3</sup>/rev [ 7.67 in<sup>3</sup>/rev]
- 160** - 159,6 cm<sup>3</sup>/rev [ 9.74 in<sup>3</sup>/rev]
- 200** - 199,8 cm<sup>3</sup>/rev [12.19 in<sup>3</sup>/rev]
- 250** - 250,1 cm<sup>3</sup>/rev [15.26 in<sup>3</sup>/rev]
- 315** - 315,7 cm<sup>3</sup>/rev [19.26 in<sup>3</sup>/rev]
- 400** - 397,0 cm<sup>3</sup>/rev [24.40 in<sup>3</sup>/rev]

**Pos.5 - Shaft Extensions\*(see page 28)**

- C** - ø25 straight, Parallel key A8x7x32 DIN6885
- VC** - ø25 straight, Parallel key A8x7x32 DIN6885 with corrosion resistant bushing
- CO** - ø1" straight, Parallel key ¼"x¼"x1¼" BS46
- VCO** - ø1" straight, Parallel key ¼"x¼"x1¼" BS46 with corrosion resistant bushing
- SH** - ø25,32 splined BS 2059 (SAE 6B)
- VSH** - ø25,32 splined BS 2059 (SAE 6B) with corrosion resistant bushing
- K** - ø28,56 tapered 1:10, Parallel key B5x5x14 DIN6885
- SA** - ø24,5 splined B 25x22 DIN 5482
- VSA** - ø24,5 splined B 25x22 DIN 5482 with corrosion resistant bushing
- CB** - ø32 straight, Parallel key A10x8x45 DIN6885
- KB** - ø35 tapered 1:10, Parallel key B6x6x20 DIN6885
- SB** - splined A 25x22 DIN 5482
- OB** - ø1¼" tapered 1:8, Parallel key ⅝"x⅝"x1¼" BS46
- HB** - ø1¼" splined 14T ANSI B92.1 - 1976

**Pos. 6 - Shaft Seal Version (see page 30)**

- omit - Low pressure shaft seal or Standard shaft seal for "...B" shaft
- D** - Standard shaft seal
- U** - High pressure shaft seal (without check valves)

**Pos. 7 - Drain Port**

- omit - with drain port
- 1** - without drain port

**Pos. 8 - Ports**

- omit - BSPP (ISO 228)
- M** - Metric (ISO 262)

**Pos. 9 - Special Features (see page 119)**

**Pos.10 - Design Series**

- omit - Factory specified

**NOTES:** The following combinations are not allowed: - **Q** flange with "...B" shafts;  
- **N** option with "...B" shafts, Low Pressure Seal or **U** option;  
- "...B" shafts with **D** and **U** shaft seals.

\* The permissible output torque for shafts must not be exceeded!

The hydraulic motors are manganese-phosphatized as standard.

# Hydraulic motors type MR...T with tacho connection

MR motors are available in version with tacho drive shaft. With tacho connection the speed of the motor can be registered. Tacho shaft has a 6 times higher revolution speed than output shaft and opposite direction of rotation.

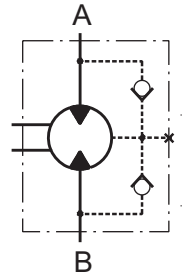

## OUTLINE DIMENSIONS REFERENCE

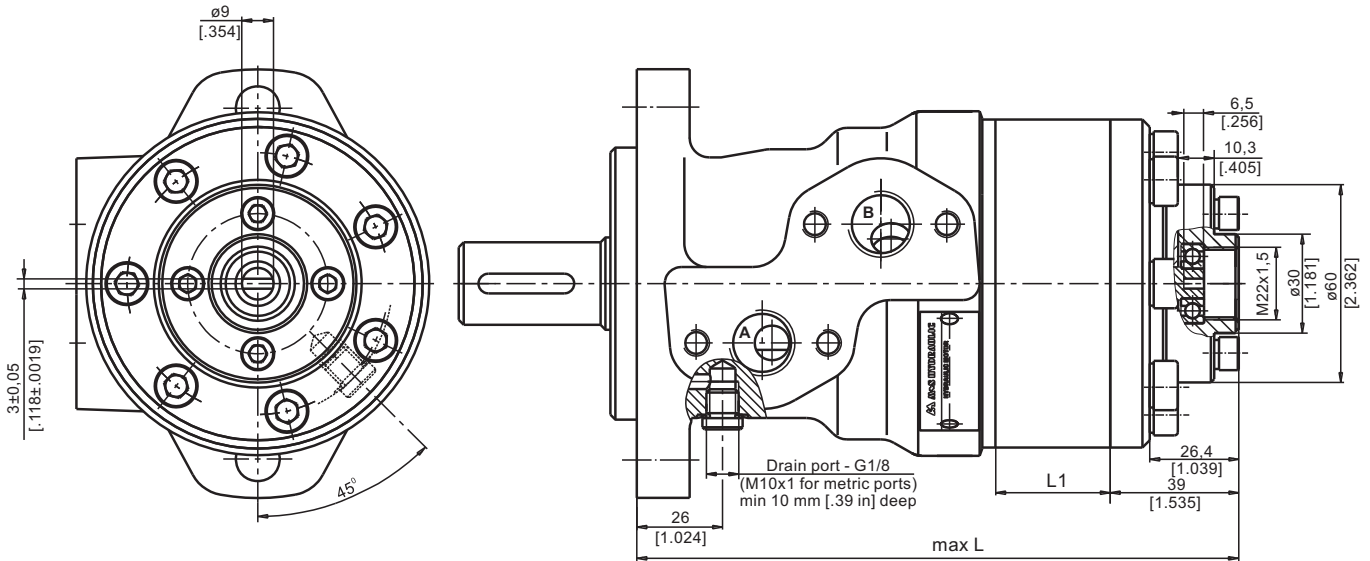

Type	L, mm [in]	L <sub>1</sub> , mm [in]
MR 50	157 [6.18]	9,0 [.35]
MR 80	162 [6.38]	14,0 [.55]
MR 100	165 [6.50]	17,4 [.69]
MR 125	170 [6.69]	21,8 [.86]
MR 160	176 [6.93]	27,8 [1.09]
MR 200	183 [7.20]	34,8 [1.37]
MR 250	192 [7.56]	43,5 [1.71]
MR 315	204 [8.03]	54,8 [2.16]
MR 400	218 [8.58]	69,4 [2.73]



### Notes:

Radial or axial load on tacho shaft must be avoided. Max. torque on tacho shaft 0,1 daNm [.885 lb-in]. Max. cont. return pressure without drain line 20 bar [290 PSI].

Tacho option for MR motor is available only for shafts with sealing diameter  $\varnothing 28,56$  with shaft seal type **D** (up to 150 bar).

It is not allowed for Q-flange.

The main technical features correspond to the standard motors series MR. There are no changes in the overall and mounting dimensions. For detail technical and mounting data please refer to MR catalogue.

# HYDRAULIC MOTORS SP

M+S Hydraulic introduces a new version of hydraulic motors, type SP with new housing, integrated output shaft to the spool valve, check valves, high pressure shaft seal. The SP motors are suitable for a wide range of applications where compact and high efficient motors are required.

## CONTENTS

Specification data .....	45÷46
Function diagrams .....	18÷24
Dimensions and mounting .....	47÷48
Shaft extensions .....	48
Permissible shaft Seal Pressure ...	48
Permissible shaft loads .....	49
Order code .....	49

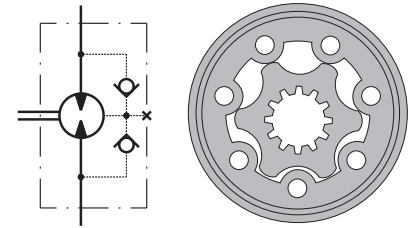

## APPLICATION

- » Conveyors
- » Feeding mechanism of robots and manipulators
- » Metal working machines
- » Textile machines
- » Agriculture machines
- » Food industries
- » Grass cutting machinery etc.

## OPTIONS

- » Model- Spool valve, gerotor
- » Flange mount - 2 hole oval flange; square flange
- » Side BSPP ports
- » Shafts- straight and splined
- » Shaft seal for high and low pressure
- » Other special features

## GENERAL

<b>Max. Displacement,</b> cm <sup>3</sup> /rev [in <sup>3</sup> /rev]	396 [24.16]
<b>Max. Speed,</b> [RPM]	1515
<b>Max. Torque,</b> daNm [lb-in]	cont.:38 [3360] int.: 46 [3240]
<b>Max. Output,</b> kW [HP]	17,5 [23.5]
<b>Max. Pressure Drop,</b> bar [PSI]	cont.:140 [2030] int.:175 [2540]
<b>Max. Oil Flow,</b> lpm [GPM]	75 [19.8]
<b>Min. Speed,</b> [RPM]	10
<b>Pressure fluid</b>	Mineral based- HLP(DIN 51524) or HM(ISO 6743/4)
<b>Temperature range,</b> °C [°F]	-30÷90 [-22÷194]
<b>Optimal Viscosity range,</b> mm <sup>2</sup> /s [SUS]	20÷75 [98÷347]
<b>Filtration</b>	ISO code 20/16 (Min. recommended fluid filtration of 25 micron)

### Oil flow in drain line

Pressure drop bar [PSI]	Viscosity mm <sup>2</sup> /s [SUS]	Oil flow in drain line lpm [GPM]
100 [1450]	20 [98]	2,5 [.660]
	35 [164]	1,8 [.476]
140 [2030]	20 [98]	3,5 [.925]
	35 [164]	2,8 [.740]

### Pressure Losses

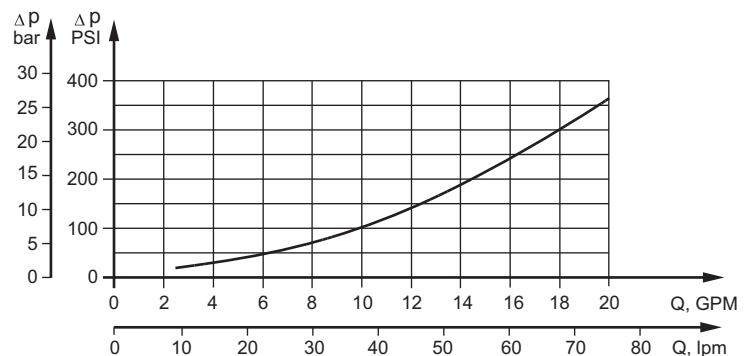

## SPECIFICATION DATA

Specification Data for SP... motors with **C** and **CO** shafts.

Type		SP 50	SP 80	SP 100	SP 125	SP 160	SP 200	SP 250	SP 315	SP 400
<b>Displacement, cm<sup>3</sup>/rev [in<sup>3</sup>/rev]</b>		49,5 [3.0]	79,2 [4.83]	99 [6.04]	123,8 [7.55]	158,4 [9.66]	198 [12.1]	247,5 [15.1]	316,8 [19.3]	396 [2416]
<b>Max. Speed, [RPM]</b>	Cont.	1210	755	605	486	378	303	242	190	150
	Int.*	1515	945	755	605	472	378	303	236	189
<b>Max. Torque daNm [lb-in]</b>	Cont.	9,4 [835]	15,1 [1340]	19,3 [1710]	23,7 [2100]	30 [2655]	30 [2655]	27,6 [2442]	29,5 [2610]	28,5 [2522]
	Int.*	11,9 [1050]	19,5 [1725]	23,7 [2100]	29,8 [2640]	37,8 [3345]	36,5 [3230]	35,5 [3142]	36,6 [4070]	36 [3185]
	Peak**	14 [1240]	22 [1950]	27 [2390]	36,5 [3230]	42 [3717]	53 [4690]	54 [4780]	59 [5222]	59 [5222]
<b>Max. Output kW [HP]</b>	Cont.	9,9 [13.3]	9,9 [13.3]	9,9 [13.3]	9,9 [13.3]	9,9 [13.3]	9,5 [12.7]	6 [8.1]	4 [5.4]	3 [4]
	Int.*	12,5 [16.8]	12,5 [16.8]	12,5 [16.8]	12,5 [16.8]	12,5 [16.8]	12,5 [16.8]	13,2 [17.7]	5,8 [7.8]	5 [6.7]
<b>Max. Pressure Drop bar [PSI]</b>	Cont.	140 [2030]	140 [2030]	140 [2030]	140 [2030]	140 [2030]	115 [1670]	85 [1233]	70 [1015]	55 [798]
	Int.*	175 [2540]	175 [2540]	175 [2540]	175 [2540]	175 [2540]	140 [2030]	110 [1450]	90 [1305]	70 [1015]
	Peak**	225 [3260]	225 [3260]	225 [3260]	225 [3260]	225 [3260]	225 [3260]	180 [2610]	160 [2320]	130 [1885]
<b>Max. Oil Flow lpm [GPM]</b>	Cont.	60 [15.9]	60 [15.9]	60 [15.9]	60 [15.9]	60 [15.9]	60 [15.9]	60 [15.9]	60 [15.9]	60 [15.9]
	Int.*	75 [19.8]	75 [19.8]	75 [19.8]	75 [19.8]	75 [19.8]	75 [19.8]	75 [19.8]	75 [19.8]	75 [19.8]
<b>Max. Starting Pressure with Unloaded Shaft, bar [PSI]</b>		10 [145]	10 [145]	10 [145]	9 [131]	8 [116]	7 [100]	6 [87]	5 [73]	5 [73]
<b>Min. Starting Torque, daNm [lb-in]</b>		7,7 [682]	14 [1240]	16,8 [1490]	21 [1860]	28 [2478]	28,5 [2522]	26,5 [2345]	26,5 [2345]	26,5 [2345]
<b>Max. Inlet Pressure bar [PSI]</b>	Cont.	175 [2540]	175 [2540]	175 [2540]	175 [2540]	175 [2540]	175 [2540]	175 [2540]	175 [2540]	175 [2540]
	Int.*	200 [2900]	200 [2900]	200 [2900]	200 [2900]	200 [2900]	200 [2900]	200 [2900]	200 [2900]	200 [2900]
	Peak**	225 [3260]	225 [3260]	225 [3260]	225 [3260]	225 [3260]	225 [3260]	225 [3260]	225 [3260]	225 [3260]

\* Intermittent operation: the permissible values may occur for max. 10% of every minute.

\*\* Peak load: the permissible values may occur for max. 1% of every minute.

\*\*\* For speeds lower than given, consult factory or your regional manager.

1. Intermittent speed and intermittent pressure must not occur simultaneously.
2. Recommended filtration is per ISO cleanliness code 20/16. A nominal filtration of 25 micron or better.
3. Recommend using a premium quality, anti-wear type mineral based hydraulic oil HLP(DIN51524) or HM ( ISO 6743/4).  
If using synthetic fluids consult the factory for alternative seal materials.
4. Recommended minimum oil viscosity 13 mm<sup>2</sup>/s [70 SUS] at 50°C [122°F].
5. Recommended maximum system operating temperature is 82°C [180°F].
6. To assure optimum motor life fill with fluid prior to loading and run at moderate load and speed for 10-15 minutes.

## SPECIFICATION DATA

Specification Data for SP... motors with **SH** shafts.

Type		SP 50	SP 80	SP 100	SP 125	SP 160	SP 200	SP 250	SP 315	SP 400
<b>Displacement, cm<sup>3</sup>/rev [in<sup>3</sup>/rev]</b>		49,5 [3.0]	79,2 [4.83]	99 [6.04]	123,8 [7.55]	158,4 [9.66]	198 [12.1]	247,5 [15.1]	316,8 [19.3]	396 [2416]
<b>Max. Speed, [RPM]</b>	Cont.	1210	755	605	486	378	303	242	190	150
	Int.*	1515	945	755	605	472	378	303	236	189
<b>Max. Torque daNm [lb-in]</b>	Cont.	9,4 [835]	15,1 [1340]	19,3 [1710]	23,7 [2100]	30 [2655]	36,6 [3240]	38 [3360]	38 [3360]	36 [3190]
	Int.*	11,9 [1050]	19,5 [1725]	23,7 [2100]	29,8 [2640]	37,8 [3345]	45,6 [4035]	45 [3980]	46 [3240]	46 [3240]
	Peak**	14 [1240]	22 [1950]	27 [2390]	36,5 [3230]	42 [3717]	53 [4690]	67 [5930]	85 [7523]	85 [7523]
<b>Max. Output kW [HP]</b>	Cont.	9,9 [13.3]	9,9 [13.3]	9,9 [13.3]	9,9 [13.3]	9,9 [13.3]	10,3 [13.8]	8 [10.7]	6 [8.1]	4,8 [6.4]
	Int.*	12,5 [16.8]	12,5 [16.8]	12,5 [16.8]	12,5 [16.8]	12,5 [16.8]	15,3 [20.5]	17,5 [23.5]	8,2 [10.9]	9,2 [12.3]
<b>Max. Pressure Drop bar [PSI]</b>	Cont.	140 [2030]	140 [2030]	140 [2030]	140 [2030]	140 [2030]	140 [2030]	110 [1450]	90 [1305]	70 [1015]
	Int.*	175 [2540]	175 [2540]	175 [2540]	175 [2540]	175 [2540]	175 [2540]	140 [2030]	140 [2030]	90 [1305]
	Peak**	225 [3260]	225 [3260]	225 [3260]	225 [3260]	225 [3260]	225 [3260]	225 [3260]	225 [3260]	180 [2610]
<b>Max. Oil Flow lpm [GPM]</b>	Cont.	60 [15.9]	60 [15.9]	60 [15.9]	60 [15.9]	60 [15.9]	60 [15.9]	60 [15.9]	60 [15.9]	60 [15.9]
	Int.*	75 [19.8]	75 [19.8]	75 [19.8]	75 [19.8]	75 [19.8]	75 [19.8]	75 [19.8]	75 [19.8]	75 [19.8]
<b>Max. Starting Pressure with Unloaded Shaft, bar [PSI]</b>		10 [145]	10 [145]	10 [145]	9 [131]	8 [116]	7 [100]	6 [87]	5 [73]	5 [73]
<b>Min. Starting Torque, daNm [lb-in]</b>		7,7 [682]	14 [1240]	16,8 [1490]	21 [1860]	28 [2478]	34,6 [3062]	34,5 [3050]	35 [3098]	35 [3098]
<b>Max. Inlet Pressure bar [PSI]</b>	Cont.	175 [2540]	175 [2540]	175 [2540]	175 [2540]	175 [2540]	175 [2540]	175 [2540]	175 [2540]	175 [2540]
	Int.*	200 [2900]	200 [2900]	200 [2900]	200 [2900]	200 [2900]	200 [2900]	200 [2900]	200 [2900]	200 [2900]
	Peak**	225 [3260]	225 [3260]	225 [3260]	225 [3260]	225 [3260]	225 [3260]	225 [3260]	225 [3260]	225 [3260]

\* Intermittent operation: the permissible values may occur for max. 10% of every minute.

\*\* Peak load: the permissible values may occur for max. 1% of every minute.

\*\*\* For speeds lower than given, consult factory or your regional manager.

- Intermittent speed and intermittent pressure must not occur simultaneously.
- Recommended filtration is per ISO cleanliness code 20/16. A nominal filtration of 25 micron or better.
- Recommend using a premium quality, anti-wear type mineral based hydraulic oil HLP(DIN51524) or HM (ISO 6743/4).  
If using synthetic fluids consult the factory for alternative seal materials.
- Recommended minimum oil viscosity 13 mm<sup>2</sup>/s [70 SUS] at 50°C [122°F].
- Recommended maximum system operating temperature is 82°C [180°F].
- To assure optimum motor life fill with fluid prior to loading and run at moderate load and speed for 10-15 minutes.

**DIMENSIONS AND MOUNTING DATA**

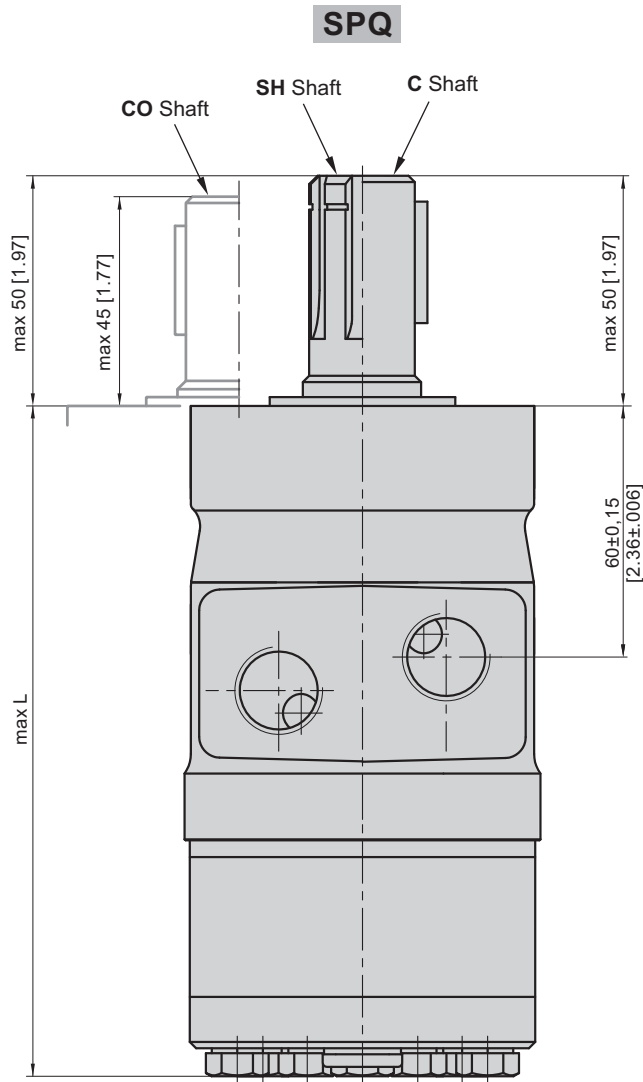
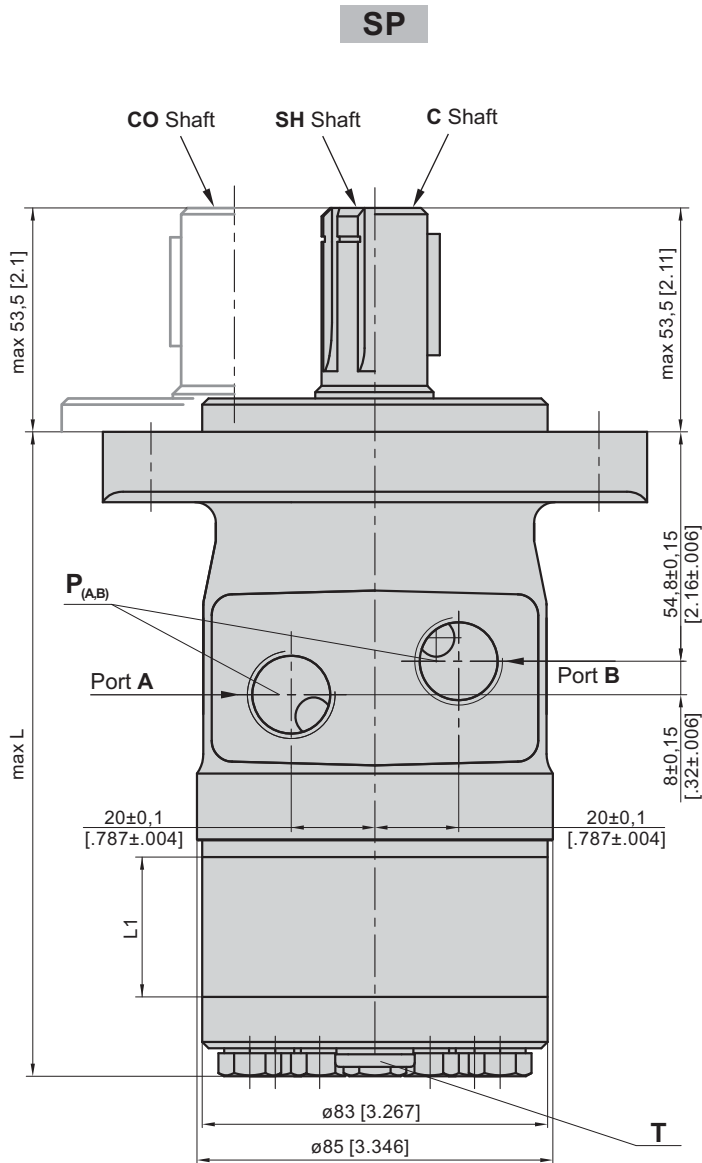

**P<sub>(A,B)</sub>** : 2xG1/2 - 18 mm [.709 in] depth

**T** : G1/4 - 12 mm [.47 in] depth

**Standard Rotation**

Viewed from Shaft End  
Port A Pressurized - **CW**  
Port B Pressurized - **CCW**

**Reverse Rotation**

Viewed from Shaft End  
Port A Pressurized - **CCW**  
Port B Pressurized - **CW**

Type	L <sub>max</sub> , mm [in]	Type	L <sub>max</sub> , mm [in]	L <sub>1</sub> , mm [in]
SP 50	128 [5.04]	SPQ 50	134 [5.28]	6,67 [.26]
SP 80	132 [5.19]	SPQ 80	138 [5.43]	10,67 [.42]
SP 100	134,5 [5.29]	SPQ 100	140,9 [5.55]	13,33 [.52]
SP 125	138 [5.43]	SPQ 125	144 [5.67]	16,67 [.66]
SP 160	142,5 [5.61]	SPQ 160	148,9 [5.86]	21,33 [.84]
SP 200	148 [5.83]	SPQ 200	154 [6.06]	26,67 [1.05]
SP 250	154,5 [6.08]	SPQ 250	160,9 [6.33]	33,33 [1.31]
SP 315	164 [6.46]	SPQ 315	170 [6.69]	42,67 [1.68]
SP 400	174,5 [6.87]	SPQ 400	180,9 [7.12]	53,33 [2.10]



**MOUNTING**

Oval Mount (2 Holes)

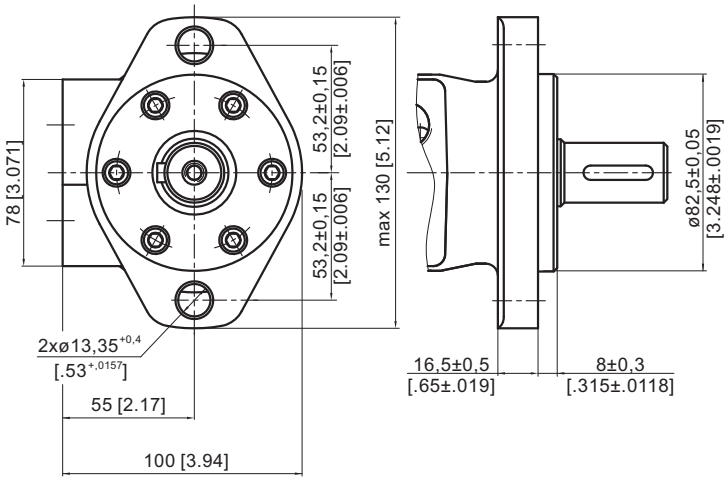

**Q** Square Mount (4 bolts)

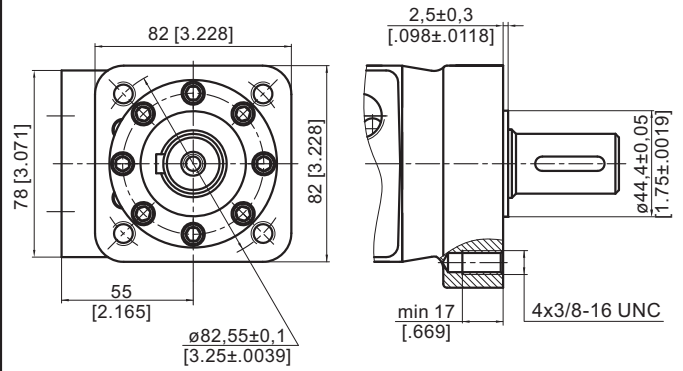

**SHAFT EXTENSIONS**

**C** -  $\varnothing 25$  straight, Parallel key A8x7x30 DIN 6885  
Max. Torque 34 daNm [3010 lb-in]

**CO** -  $\varnothing 1$ " straight, Parallel key  $\frac{1}{4}$ "x $\frac{1}{4}$ "x1" BS46  
Max. Torque 34 daNm [3010 lb-in]

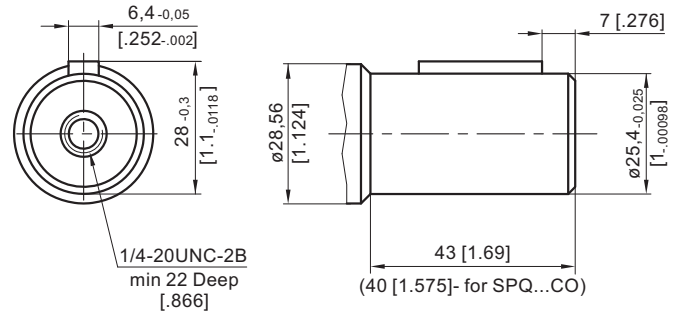
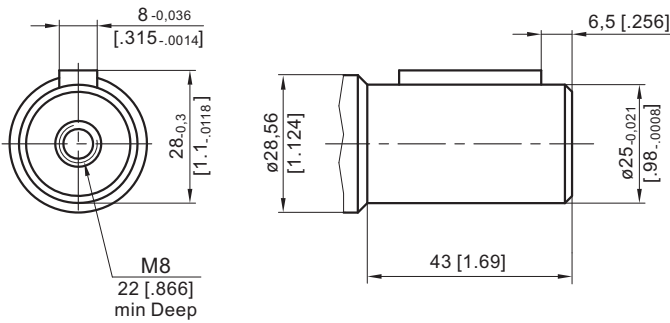

**SH** - splined, BS 2059 (SAE 6B)  
Max. Torque 40 daNm [3540 lb-in]

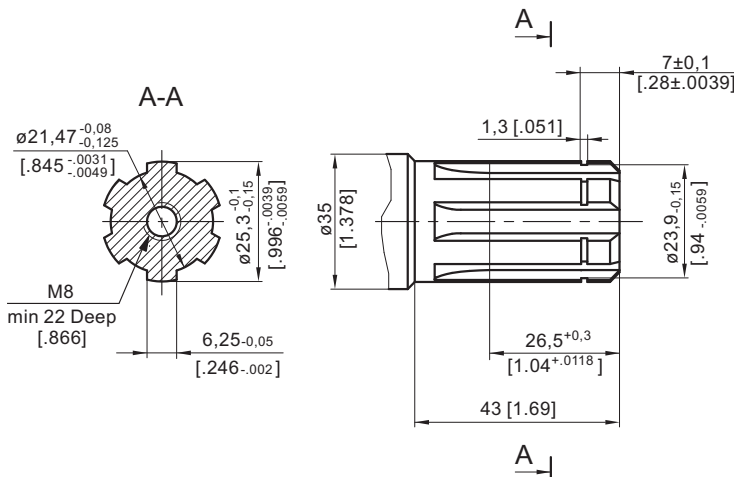

**MAX. PERMISSIBLE SHAFT SEAL PRESSURE**

Max return pressure without drain line or max. pressure in drain line

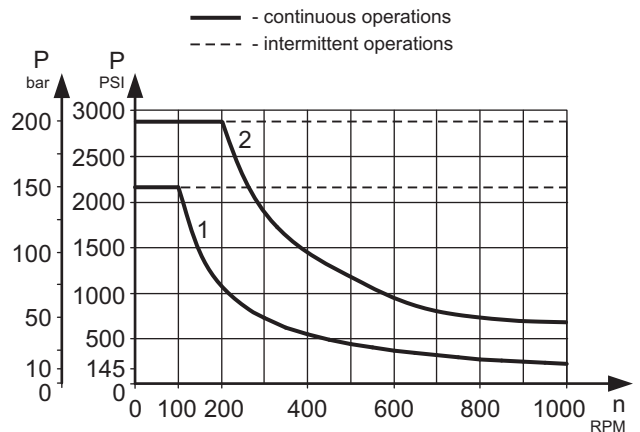

1: Curve for Standard Shaft Seal  
2: Curve for High Pressure Seal ("U" Seal)



**PERMISSIBLE SHAFT LOADS**

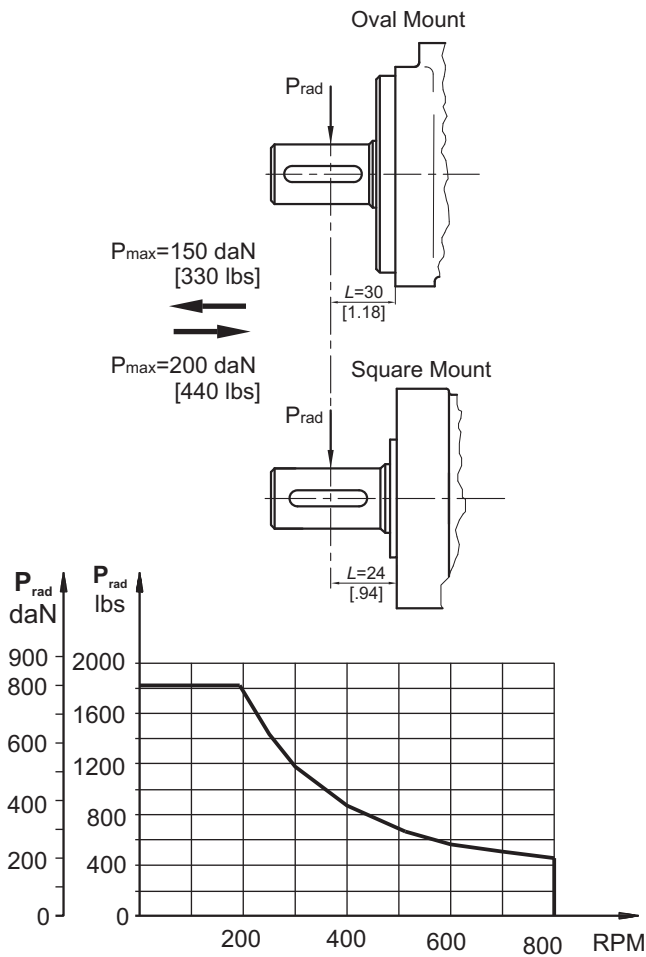

Radial Shaft Load  $P_{rad}$  for C, CO Shaft Extensions by  $L=30$  mm [1.18 in] (24 mm [.94 in])

The permissible radial shaft load depends on

- Speed (n)
- Distance (L) from the pointload to the mounting flange
- Mounting flange version

$$\text{Oval mount: } P_{rad} = \frac{800}{n} \times \frac{24300}{91,5+L} \text{ [daN]}^*$$

$$\left[ \frac{800}{\text{RPM}} \times \frac{2150}{3.6+L} \text{ [lbs]} \right]$$

$$\text{Square mount: } P_{rad} = \frac{800}{n} \times \frac{24300}{97,5+L} \text{ [daN]}^*$$

$$\left[ \frac{800}{\text{RPM}} \times \frac{2150}{3.84+L} \text{ [lbs]} \right]$$

\*  $n \leq 200$  RPM; max  $P_{rad} = 800$  daN [1800 lbs]

$n \geq 200$  RPM;  $L < 55$  mm [2.2 in]

**ORDER CODE**

	1	2	3	4	5	6
<b>SP</b>						

**Pos.1 - Mounting Flange**

- omit - Oval mount, two holes  
**Q** - Square mount, four bolts - 3/8-16 UNC

**Pos.2 - Displacement code\***

<b>50</b>	- 49,5 cm <sup>3</sup> /rev [ 3.02 in <sup>3</sup> /rev]
<b>80</b>	- 79,2 cm <sup>3</sup> /rev [ 4.83 in <sup>3</sup> /rev]
<b>100</b>	- 99,0 cm <sup>3</sup> /rev [ 6.04 in <sup>3</sup> /rev]
<b>125</b>	- 123,8 cm <sup>3</sup> /rev [ 7.55 in <sup>3</sup> /rev]
<b>160</b>	- 158,4 cm <sup>3</sup> /rev [ 9.66 in <sup>3</sup> /rev]
<b>200</b>	- 198,0 cm <sup>3</sup> /rev [12.10 in <sup>3</sup> /rev]
<b>250</b>	- 247,5 cm <sup>3</sup> /rev [15.10 in <sup>3</sup> /rev]
<b>315</b>	- 316,8 cm <sup>3</sup> /rev [19.30 in <sup>3</sup> /rev]
<b>400</b>	- 396,0 cm <sup>3</sup> /rev [24.16 in <sup>3</sup> /rev]

**Pos.3 - Shaft Extensions\*\***

- C** -  $\varnothing 25$  straight, Parallel key A8x7x30 DIN6885  
**CO** -  $\varnothing 1$ " straight, Parallel key  $1/4$ "x $1/4$ "x $1/4$ " BS46  
**SH** -  $\varnothing 25,3$  splined, BS 2059 (SAE 6B)

**Pos.4 - Shaft Seal Version**

- omit - Standard shaft seal  
**U** - High pressure shaft seal

**Pos.5 - Special Features (see page 119)**

**Pos.6 - Design Series**

- omit - Factory specified

**NOTES:**

- \* For the Function Diagrams data please look at "M+S Hydraulic" Catalogue for MP motors, pages 18÷24.  
 \*\* The permissible output torque for shafts must not be exceeded!

The hydraulic motors are mangano-phosphatized as standard.

# HYDRAULIC MOTORS SR

M+S Hydraulic introduces a new version of hydraulic motors, type SR with new housing, integrated output shaft to the spool valve, check valves, high pressure shaft seal. The SR motors are suitable for a wide range of applications where compact and high efficient motors are required.

## CONTENTS

Specification data .....	51+53
Function diagrams .....	35 39
Dimensions and mounting .....	54+56
Shaft extensions .....	57
Permissible shaft Seal Pressure ...	57
Permissible shaft loads .....	58
Order code .....	58

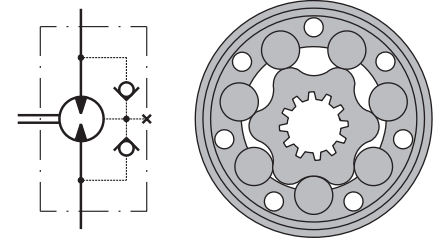

## APPLICATION

- » Conveyors
- » Feeding mechanism of robots and manipulators
- » Metal working machines
- » Textile machines
- » Agriculture machines
- » Food industries
- » Grass cutting machinery etc.

## OPTIONS

- » Model - Spool valve, geroller
- » Flange mount - 2 hole oval flange; 6 hole oval flange; square flange
- » Side BSPP ports
- » Shafts- straight, splined and tapered
- » Shaft seal for high and low pressure
- » Other special features

## GENERAL

<b>Max. Displacement,</b> cm <sup>3</sup> /rev [in <sup>3</sup> /rev]	397 [24.4]
<b>Max. Speed,</b> [RPM]	970
<b>Max. Torque,</b> daNm [lb-in]	cont.: 60 [5310] int.: 69 [6107]
<b>Max. Output,</b> kW [HP]	15 [20.1]
<b>Max. Pressure Drop,</b> bar [PSI]	cont.: 175 [2540] int.: 200 [2900]
<b>Max. Oil Flow,</b> lpm [GPM]	75 [19.8]
<b>Min. Speed,</b> [RPM]	10
<b>Pressure fluid</b>	Mineral based- HLP(DIN 51524) or HM(ISO 6743/4)
<b>Temperature range,</b> °C [°F]	-30÷90 [-22÷194]
<b>Optimal Viscosity range,</b> mm <sup>2</sup> /s [SUS]	20÷75 [98÷347]
<b>Filtration</b>	ISO code 20/16 (Min. recommended fluid filtration of 25 micron)

### Oil flow in drain line

Pressure drop bar [PSI]	Viscosity mm <sup>2</sup> /s [SUS]	Oil flow in drain line lpm [GPM]
100 [1450]	20 [98]	2,5 [.660]
	35 [164]	1,8 [.476]
140 [2030]	20 [98]	3,5 [.925]
	35 [164]	2,8 [.740]

### Pressure Losses

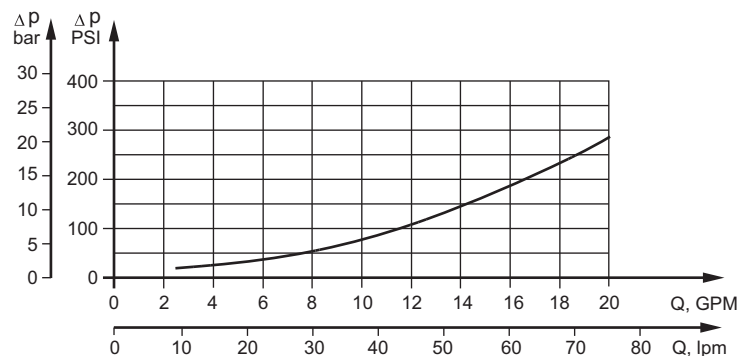

## SPECIFICATION DATA

Specification Data for SR... motors with **C** and **CO** shafts.

Type		SR 50	SR 80	SR 100	SR 125	SR 160	SR 200	SR 250	SR 315	SR 400
<b>Displacement, cm<sup>3</sup>/rev [in<sup>3</sup>/rev]</b>		51,5 [3.14]	80,3 [4.90]	99,8 [6.09]	125,7 [7.67]	159,6 [9.74]	199,8 [12.19]	250,1 [15.26]	315,7 [19.26]	397 [24.4]
<b>Max. Speed, [RPM]</b>	Cont.	775	750	600	475	375	300	240	190	150
	Int.*	970	940	750	600	470	375	300	240	190
<b>Max. Torque daNm [lb-in]</b>	Cont.	10 [900]	20 [1770]	24 [2125]	30 [2655]	29 [2566]	29 [2566]	30 [2655]	30 [2655]	30 [2655]
	Int.*	13 [1150]	22 [1947]	28 [2480]	34 [3010]	39 [3450]	39 [3450]	39 [3450]	42 [3717]	40 [3540]
	Peak**	17 [1505]	27 [2390]	32 [2832]	37 [3275]	46 [4070]	56 [4960]	60 [5310]	61 [5400]	61 [5400]
<b>Max. Output kW [HP]</b>	Cont.	7 [9.4]	12,5 [17]	13 [17.4]	12,5 [17]	9 [12]	7,5 [10]	6 [8.1]	5 [6.7]	3,8 [5.1]
	Int.*	8,5 [11.4]	15 [20.1]	15 [20.1]	14,5 [19.5]	12,5 [17]	10 [13.4]	8 [10.7]	6,5 [8.7]	6,1 [8.2]
<b>Max. Pressure Drop bar [PSI]</b>	Cont.	140 [2030]	175 [2540]	175 [2540]	175 [2540]	120 [1740]	105 [1520]	80 [1160]	70 [1015]	55 [798]
	Int.*	175 [2540]	200 [2900]	200 [2900]	200 [2900]	175 [2540]	140 [2030]	110 [1600]	100 [1450]	70 [1015]
	Peak**	225 [3260]	225 [3260]	225 [3260]	225 [3260]	225 [3260]	225 [3260]	200 [2900]	150 [2175]	115 [1668]
<b>Max. Oil Flow lpm [GPM]</b>	Cont.	40 [10.5]	60 [15.8]	60 [15.8]	60 [15.8]	60 [15.8]	60 [15.8]	60 [15.8]	60 [15.8]	60 [15.8]
	Int.*	50 [13.2]	75 [19.8]	75 [19.8]	75 [19.8]	75 [19.8]	75 [19.8]	75 [19.8]	75 [19.8]	75 [19.8]
<b>Max. Starting Pressure with Unloaded Shaft, bar [PSI]</b>		10 [145]	10 [145]	10 [145]	9 [130]	7 [102]	5 [73]	4 [58]	3 [43.5]	3 [43.5]
<b>Min. Starting Torque, daNm [lb-in]</b>		8 [710]	15 [1330]	20 [1770]	24 [2124]	23 [2035]	23 [2035]	24 [2124]	26 [2300]	26 [2300]
<b>Max. Inlet Pressure bar [PSI]</b>	Cont.	175 [2540]	175 [2540]	175 [2540]	175 [2540]	175 [2540]	175 [2540]	175 [2540]	175 [2540]	175 [2540]
	Int.*	200 [2900]	200 [2900]	200 [2900]	200 [2900]	200 [2900]	200 [2900]	200 [2900]	200 [2900]	200 [2900]
	Peak**	225 [3260]	225 [3260]	225 [3260]	225 [3260]	225 [3260]	225 [3260]	225 [3260]	225 [3260]	225 [3260]

\* Intermittent operation: the permissible values may occur for max. 10% of every minute.

\*\* Peak load: the permissible values may occur for max. 1% of every minute.

\*\*\* For speeds lower than given, consult factory or your regional manager.

1. Intermittent speed and intermittent pressure must not occur simultaneously.
2. Recommended filtration is per ISO cleanliness code 20/16. A nominal filtration of 25 micron or better.
3. Recommend using a premium quality, anti-wear type mineral based hydraulic oil HLP(DIN51524) or HM ( ISO 6743/4).  
If using synthetic fluids consult the factory for alternative seal materials.
4. Recommended minimum oil viscosity 13 mm<sup>2</sup>/s [70 SUS] at 50°C [122°F].
5. Recommended maximum system operating temperature is 82°C [180°F].
6. To assure optimum motor life fill with fluid prior to loading and run at moderate load and speed for 10-15 minutes.

## SPECIFICATION DATA

Specification Data for SR... motors with SH shafts.

Type		SR 50	SR 80	SR 100	SR 125	SR 160	SR 200	SR 250	SR 315	SR 400
<b>Displacement, cm<sup>3</sup>/rev [in<sup>3</sup>/rev]</b>		51,5 [3.14]	80,3 [4.90]	99,8 [6.09]	125,7 [7.67]	159,6 [9.74]	199,8 [12.19]	250,1 [15.26]	315,7 [19.26]	397 [24.4]
<b>Max. Speed, [RPM]</b>	Cont.	775	750	600	475	375	300	240	190	150
	Int.*	970	940	750	600	470	375	300	240	190
<b>Max. Torque daNm [lb-in]</b>	Cont.	10 [900]	20 [1770]	24 [2125]	30 [2655]	39 [3450]	38,5 [3410]	38 [3360]	39 [3450]	38 [3360]
	Int.*	13 [1150]	22 [1947]	28 [2480]	34 [3010]	43 [3805]	46 [4070]	47 [4160]	48 [4248]	47 [4160]
	Peak**	17 [1505]	27 [2390]	32 [2832]	37 [3275]	46 [4070]	56 [4960]	60 [5310]	61 [5400]	61 [5400]
<b>Max. Output kW [HP]</b>	Cont.	7 [9,4]	12,5 [17]	13 [17.4]	12,5 [17]	11,5 [15.4]	9 [12]	8 [10.7]	5 [6.7]	4,8 [6.4]
	Int.*	8,5 [11,4]	15 [20.1]	15 [20.1]	14,5 [19.5]	14 [18.8]	12 [16.1]	9,5 [12.7]	8 [10.7]	6,8 [9.1]
<b>Max. Pressure Drop bar [PSI]</b>	Cont.	140 [2030]	175 [2540]	175 [2540]	175 [2540]	175 [2540]	140 [2030]	110 [1600]	85 [1232]	70 [1015]
	Int.*	175 [2540]	200 [2900]	200 [2900]	200 [2900]	200 [2900]	175 [2540]	140 [2030]	115 [1668]	90 [1305]
	Peak**	225 [3260]	225 [3260]	225 [3260]	225 [3260]	225 [3260]	225 [3260]	200 [2900]	150 [2175]	115 [1668]
<b>Max. Oil Flow lpm [GPM]</b>	Cont.	40 [10.5]	60 [15.8]	60 [15.8]	60 [15.8]	60 [15.8]	60 [15.8]	60 [15.8]	60 [15.8]	60 [15.8]
	Int.*	50 [13.2]	75 [19.8]	75 [19.8]	75 [19.8]	75 [19.8]	75 [19.8]	75 [19.8]	75 [19.8]	75 [19.8]
<b>Max. Starting Pressure with Unloaded Shaft, bar [PSI]</b>		10 [145]	10 [145]	10 [145]	9 [130]	7 [102]	5 [73]	4 [58]	3 [43.5]	3 [43.5]
<b>Min. Starting Torque, daNm [lb-in]</b>		8 [710]	15 [1330]	20 [1770]	24 [2124]	32 [2832]	33 [2920]	31 [2740]	31,5 [2788]	31,5 [2788]
<b>Max. Inlet Pressure bar [PSI]</b>	Cont.	175 [2540]	175 [2540]	175 [2540]	175 [2540]	175 [2540]	175 [2540]	175 [2540]	175 [2540]	175 [2540]
	Int.*	200 [2900]	200 [2900]	200 [2900]	200 [2900]	200 [2900]	200 [2900]	200 [2900]	200 [2900]	200 [2900]
	Peak**	225 [3260]	225 [3260]	225 [3260]	225 [3260]	225 [3260]	225 [3260]	225 [3260]	225 [3260]	225 [3260]

\* Intermittent operation: the permissible values may occur for max. 10% of every minute.

\*\* Peak load: the permissible values may occur for max. 1% of every minute.

\*\*\* For speeds lower than given, consult factory or your regional manager.

1. Intermittent speed and intermittent pressure must not occur simultaneously.
2. Recommended filtration is per ISO cleanliness code 20/16. A nominal filtration of 25 micron or better.
3. Recommend using a premium quality, anti-wear type mineral based hydraulic oil HLP(DIN51524) or HM ( ISO 6743/4).  
If using synthetic fluids consult the factory for alternative seal materials.
4. Recommended minimum oil viscosity 13 mm<sup>2</sup>/s [70 SUS] at 50°C [122°F].
5. Recommended maximum system operating temperature is 82°C [180°F].
6. To assure optimum motor life fill with fluid prior to loading and run at moderate load and speed for 10-15 minutes.

## SPECIFICATION DATA

Specification Data for SR... motors with **K, CB, CA** shafts.

Type		SR 50	SR 80	SR 100	SR 125	SR 160	SR 200	SR 250	SR 315	SR 400
<b>Displacement, cm<sup>3</sup>/rev [in<sup>3</sup>/rev]</b>		51,5 [3.14]	80,3 [4.90]	99,8 [6.09]	125,7 [7.67]	159,6 [9.74]	199,8 [12.19]	250,1 [15.26]	315,7 [19.26]	397 [24.4]
<b>Max. Speed, [RPM]</b>	Cont.	775	750	600	475	375	300	240	190	150
	Int.*	970	940	750	600	470	375	300	240	190
<b>Max. Torque daNm [lb-in]</b>	Cont.	10 [900]	20 [1770]	24 [2125]	30 [2655]	39 [3450]	45 [3983]	57 [5045]	57 [5045]	60 [5310]
	Int.*	13 [1150]	22 [1947]	28 [2480]	34 [3010]	43 [3805]	50 [4425]	61 [5400]	69 [6107]	69 [6107]
	Peak**	17 [1505]	27 [2390]	32 [2832]	37 [3275]	46 [4070]	56 [4960]	71 [6284]	84 [7434]	87 [8700]
<b>Max. Output kW [HP]</b>	Cont.	7 [9,4]	12,5 [17]	13 [17.4]	12,5 [17]	11,5 [15.4]	11 [14.7]	10 [13.4]	9 [12]	7,8 [10.5]
	Int.*	8,5 [11,4]	15 [20.1]	15 [20.1]	14,5 [19.5]	14 [18.8]	13 [17.4]	12 [16.1]	10 [13.4]	10,6 [14.2]
<b>Max. Pressure Drop bar [PSI]</b>	Cont.	140 [2030]	175 [2540]	175 [2540]	175 [2540]	175 [2540]	175 [2540]	175 [2540]	135 [1958]	110 [1600]
	Int.*	175 [2540]	200 [2900]	200 [2900]	200 [2900]	200 [2900]	200 [2900]	200 [2900]	175 [2540]	140 [2030]
	Peak**	225 [3260]	225 [3260]	225 [3260]	225 [3260]	225 [3260]	225 [3260]	225 [3260]	210 [3045]	175 [2540]
<b>Max. Oil Flow lpm [GPM]</b>	Cont.	40 [10.5]	60 [15.8]	60 [15.8]	60 [15.8]	60 [15.8]	60 [15.8]	60 [15.8]	60 [15.8]	60 [15.8]
	Int.*	50 [13.2]	75 [19.8]	75 [19.8]	75 [19.8]	75 [19.8]	75 [19.8]	75 [19.8]	75 [19.8]	75 [19.8]
<b>Max. Starting Pressure with Unloaded Shaft, bar [PSI]</b>		10 [145]	10 [145]	10 [145]	9 [130]	7 [102]	5 [73]	4 [58]	3 [43.5]	3 [43.5]
<b>Min. Starting Torque, daNm [lb-in]</b>		8 [710]	15 [1330]	20 [1770]	24 [2124]	32 [2832]	41 [3630]	50 [4425]	50 [4425]	50 [4425]
<b>Max. Inlet Pressure bar [PSI]</b>	Cont.	175 [2540]	175 [2540]	175 [2540]	175 [2540]	175 [2540]	175 [2540]	175 [2540]	175 [2540]	175 [2540]
	Int.*	200 [2900]	200 [2900]	200 [2900]	200 [2900]	200 [2900]	200 [2900]	200 [2900]	200 [2900]	200 [2900]
	Peak**	225 [3260]	225 [3260]	225 [3260]	225 [3260]	225 [3260]	225 [3260]	225 [3260]	225 [3260]	225 [3260]

\* Intermittent operation: the permissible values may occur for max. 10% of every minute.

\*\* Peak load: the permissible values may occur for max. 1% of every minute.

\*\*\* For speeds lower than given, consult factory or your regional manager.

1. Intermittent speed and intermittent pressure must not occur simultaneously.
2. Recommended filtration is per ISO cleanliness code 20/16. A nominal filtration of 25 micron or better.
3. Recommend using a premium quality, anti-wear type mineral based hydraulic oil HLP(DIN51524) or HM ( ISO 6743/4).  
If using synthetic fluids consult the factory for alternative seal materials.
4. Recommended minimum oil viscosity 13 mm<sup>2</sup>/s [70 SUS] at 50°C [122°F].
5. Recommended maximum system operating temperature is 82°C [180°F].
6. To assure optimum motor life fill with fluid prior to loading and run at moderate load and speed for 10-15 minutes.

**DIMENSIONS AND MOUNTING DATA**

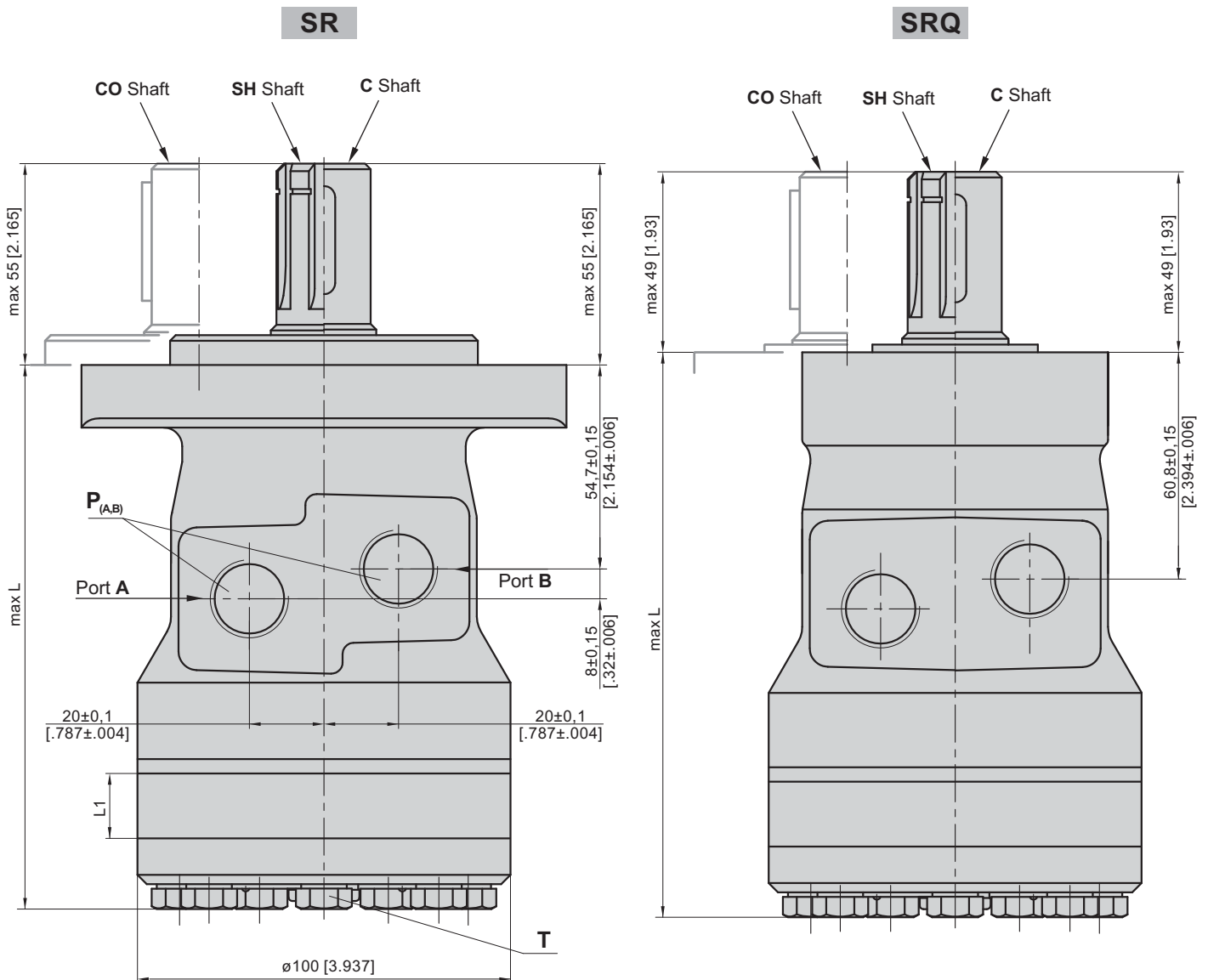

**P<sub>(A,B)</sub>**: 2xG1/2 - 18 mm [.709 in] depth  
**T**: G1/4 - 12 mm [.47 in] depth

**Standard Rotation**  
 Viewed from Shaft End  
 Port A Pressurized - CW  
 Port B Pressurized - CCW

**Reverse Rotation**  
 Viewed from Shaft End  
 Port A Pressurized - CCW  
 Port B Pressurized - CW

Type	L <sub>max</sub> , mm [in]	Type	L <sub>max</sub> , mm [in]	L <sub>1</sub> , mm [in]
SR(F) 50	138 [5.43]	SRQ 50	144 [5.67]	9,0 [.35]
SR(F) 80	143 [5.63]	SRQ 80	149 [5.87]	14,0 [.55]
SR(F) 100	146,5 [5.77]	SRQ 100	152,6 [6.0]	17,4 [.69]
SR(F) 125	151 [5.94]	SRQ 125	157 [6.18]	21,8 [.89]
SR(F) 160	157 [6.18]	SRQ 160	163 [6.42]	27,8 [1.09]
SR(F) 200	164 [6.46]	SRQ 200	170 [6.69]	34,8 [1.37]
SR(F) 250	172,5 [6.79]	SRQ 250	178,5 [7.03]	43,5 [1.71]
SR(F) 315	184 [7.24]	SRQ 315	190 [7.48]	54,8 [2.16]
SR(F) 400	198,5 [7.81]	SRQ 400	205,5 [8.9]	69,4 [2.73]



**DIMENSIONS AND MOUNTING DATA**

**SRF...**

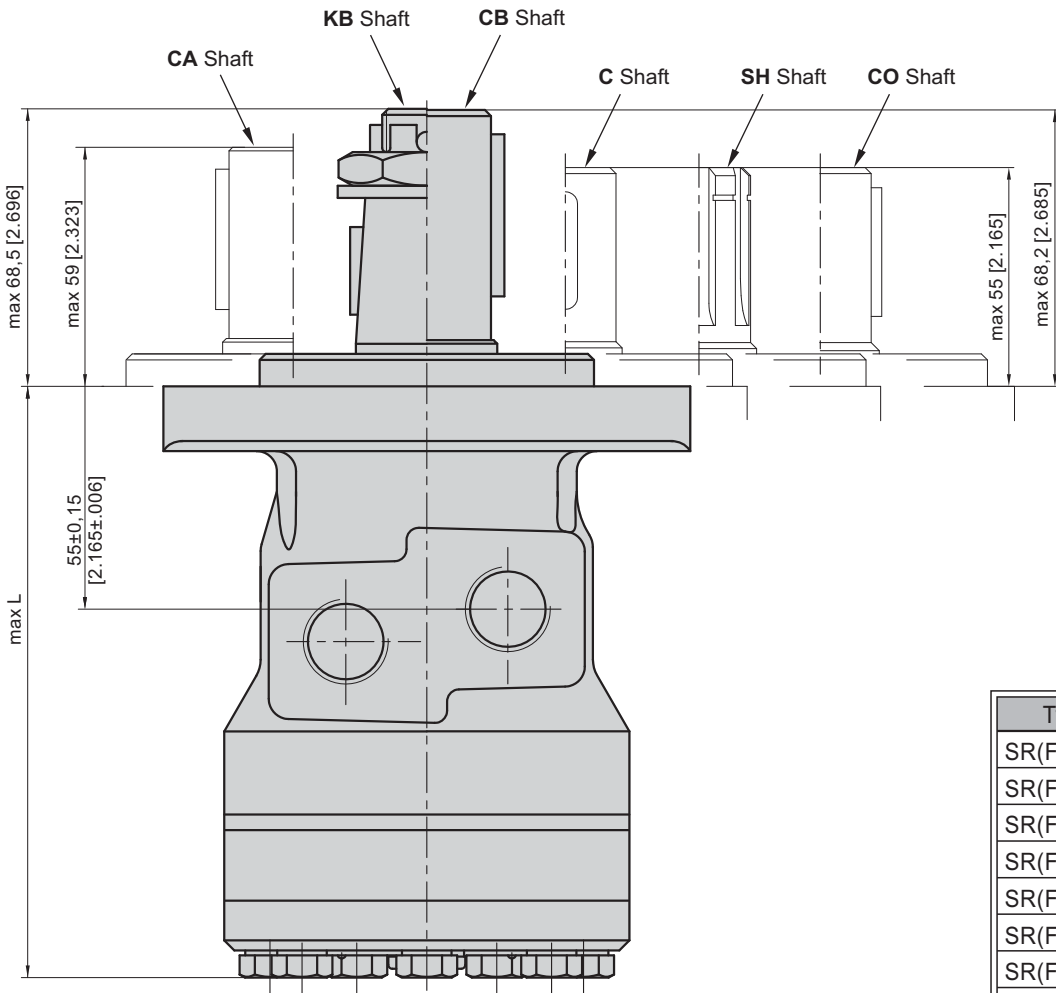

Type	L <sub>max</sub> , mm [in]	L <sub>1</sub> , mm [in]
SR(F) 50 T	157 [6.18]	9,0 [.35]
SR(F) 80 T	162 [6.38]	14,0 [.55]
SR(F) 100 T	166 [6.53]	17,4 [.69]
SR(F) 125 T	170 [6.69]	21,8 [.89]
SR(F) 160 T	176 [6.93]	27,8 [1.09]
SR(F) 200 T	183 [7.20]	34,8 [1.37]
SR(F) 250 T	191 [7.52]	43,5 [1.71]
SR(F) 315 T	203 [7.99]	54,8 [2.16]
SR(F) 400 T	217 [8.54]	69,4 [2.73]

**SR(F)...T**

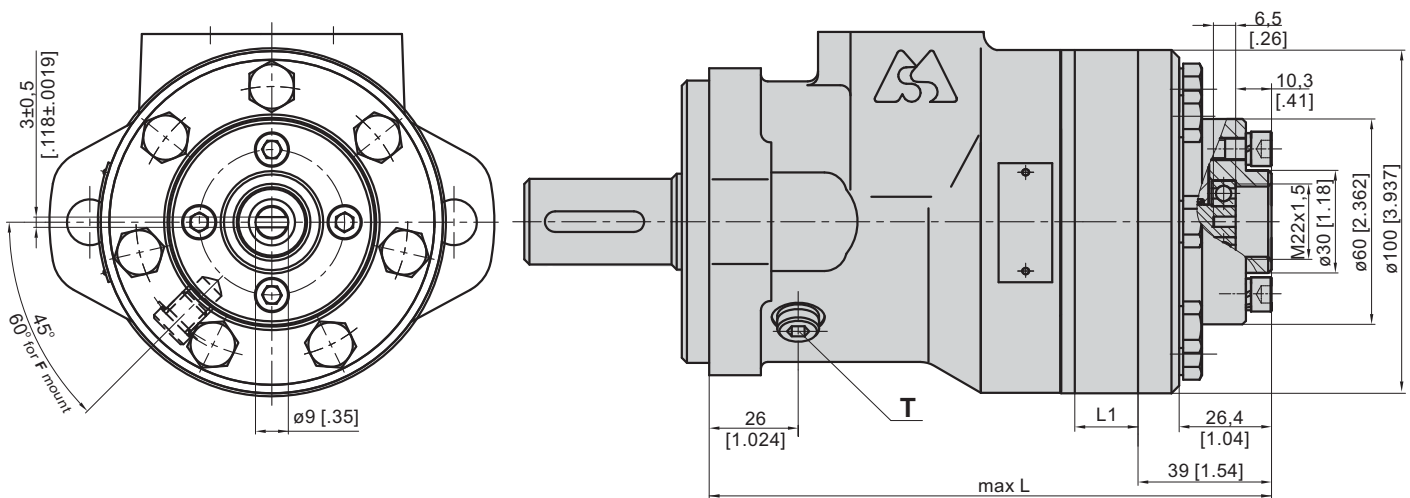

**T** : G1/8 - 10 mm [.39 in] depth for SR(F)...T

**MOUNTING**

Oval Mount (2 Holes)

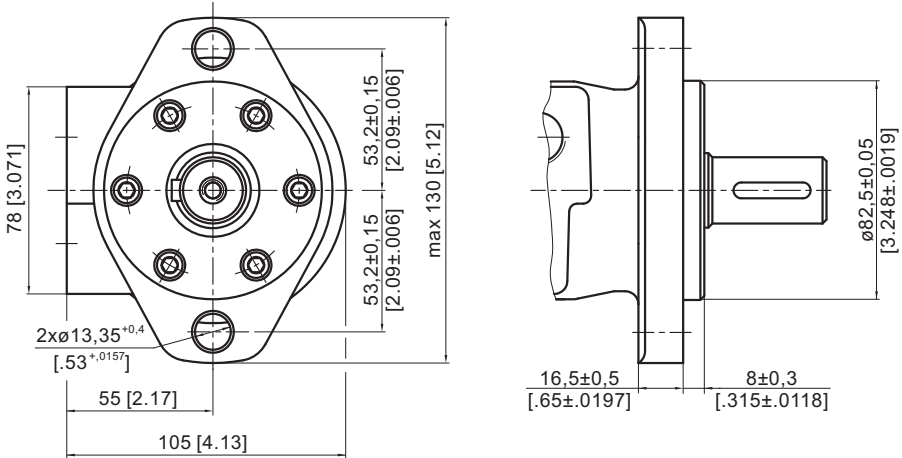

**F** Oval Mount (6 holes)

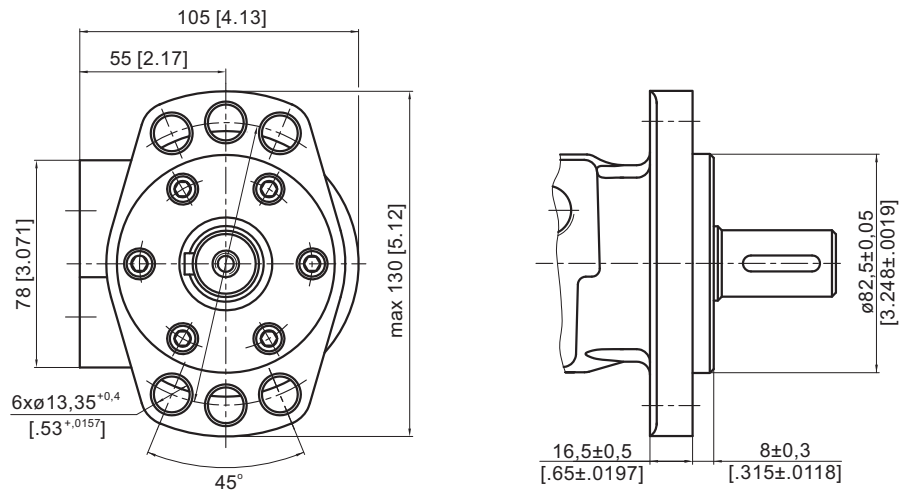

**Q** Square Mount (4 bolts)

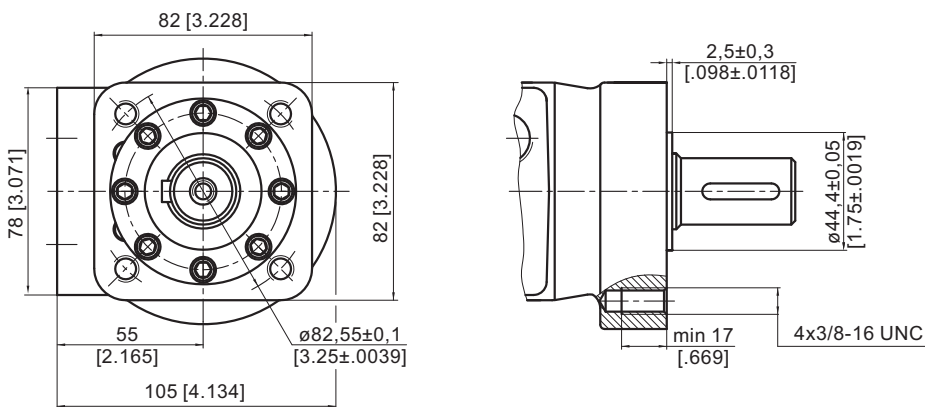

**SHAFT EXTENSIONS**

**C** -  $\varnothing 25$  straight, Parallel key A8x7x30 DIN 6885  
Max. Torque 34 daNm [3010 lb-in]

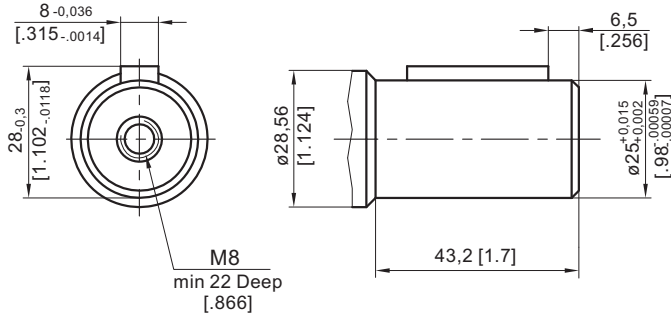

**CO** -  $\varnothing 1$ " straight, Parallel key  $\frac{1}{4} \times \frac{1}{4} \times 1 \frac{1}{4}$ " BS46  
Max. Torque 34 daNm [3010 lb-in]

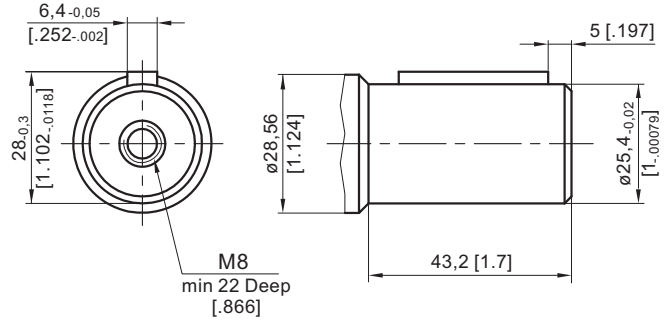

**SH** - splined, BS 2059 (SAE 6B)  
Max. Torque 40 daNm [3540 lb-in]

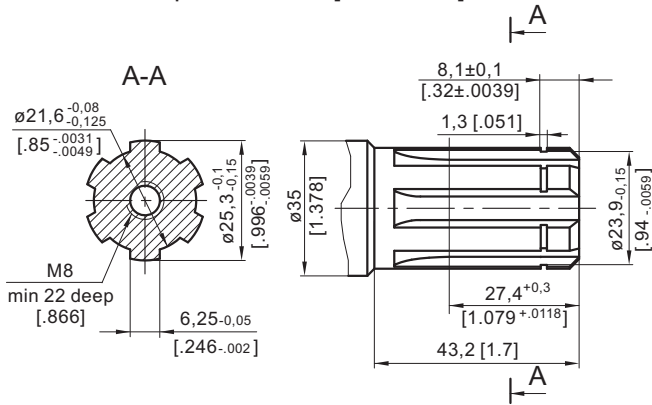

**CB** -  $\varnothing 32$  straight, Parallel key 10x8x40 DIN 6885  
Max. Torque 77 daNm [6815 lb-in]  
(for F-flange only)

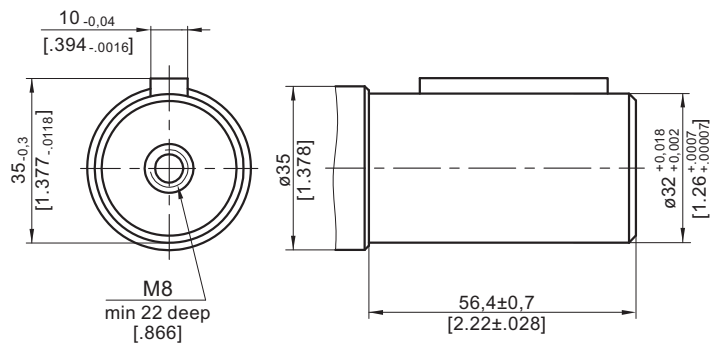

**K** - tapered 1:10, Woodruff key 6x9 DIN 6888  
Max. Torque 95 daNm [8410 lb-in]  
(for F-flange only)

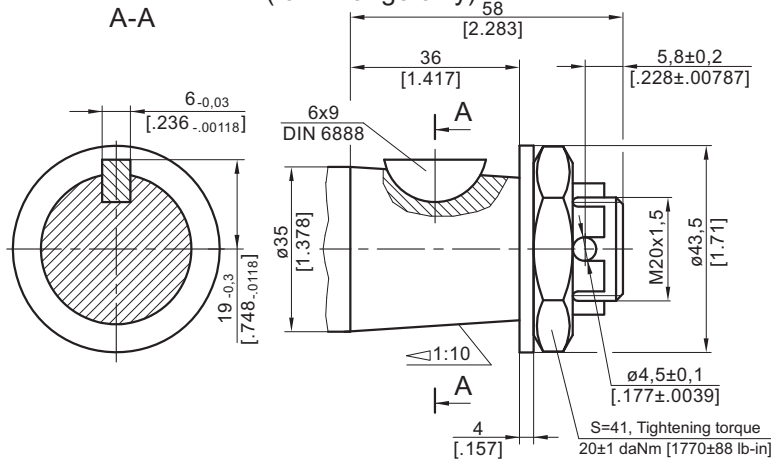

**CA** -  $\varnothing 1 \frac{1}{4}$ " straight, Parallel key  $\frac{5}{16} \times \frac{5}{16} \times 1 \frac{1}{4}$ " BS46  
Max. Torque 77 daNm [6815 lb-in]  
(for F-flange only)

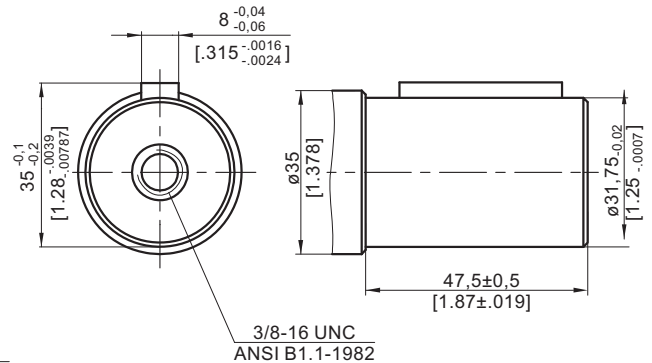

**MAX. PERMISSIBLE SHAFT SEAL PRESSURE**

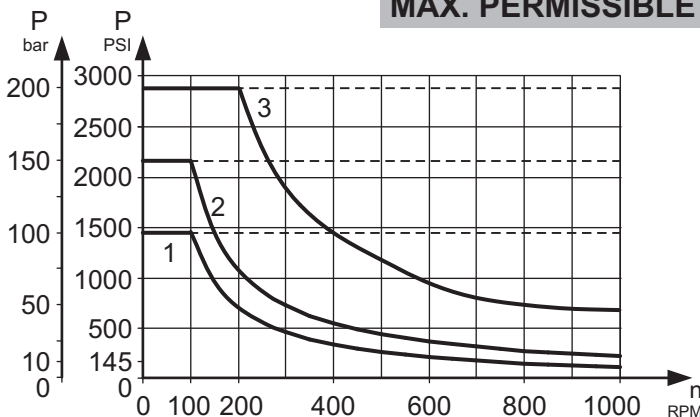

Max return pressure without drain line or max. pressure in drain line

— - continuous operations  
- - - - intermittent operations

- 1: Curve for Standard Shaft Seal for **K**, **CA**, **CB** shafts
- 2: Curve for Standard Shaft Seal for **C**, **CO**, **SH** shafts
- 3: Curve for High Pressure Seal ("U" Seal) for **C**, **CO**, **SH** shafts. Not applicable for **K**, **CA** and **CB** shafts!



**Permissible Shaft Loads SR**

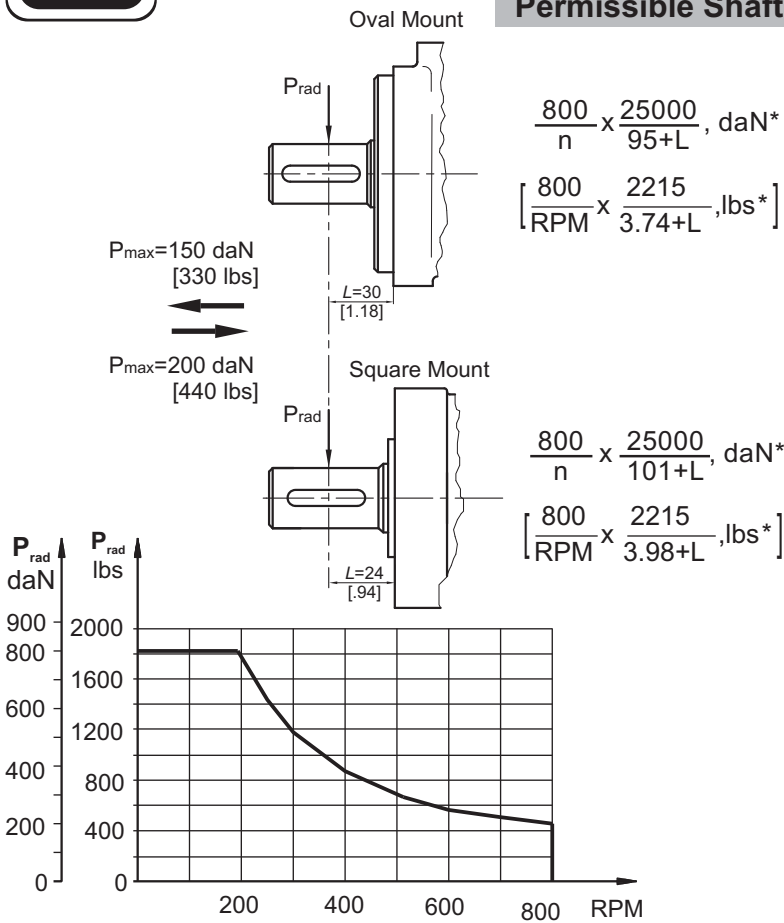

Radial Shaft Load  $P_{\text{rad}}$  for C, CO Shaft Extensions by  $L=30 \text{ mm}$  [1.18 in] (24 mm [.94 in])

The permissible radial shaft load  $P_{\text{rad}}$  depends on the speed  $n$ , RPM, distance  $L$  from the point of load to the mounting flange and shaft version.

\*  $n \leq 200 \text{ RPM}$ ; max  $P_{\text{rad}}=800 \text{ daN}$  [1800 lbs]  
 $n \geq 200 \text{ RPM}$ ;  $L < 55 \text{ mm}$  [2.2 in]

**ORDER CODE**

	1	2	3	4	5	6	7
<b>SR</b>							

**Pos.1 - Mounting Flange**

- omit - Oval mount, two holes
- F** - Oval mount, six holes
- Q** - Square mount, four bolts - 3/8-16 UNC

**Pos.2 - Displacement code\*\***

<b>50</b>	- 51,5 cm <sup>3</sup> /rev [ 3.14 in <sup>3</sup> /rev]
<b>80</b>	- 80,3 cm <sup>3</sup> /rev [ 4.90 in <sup>3</sup> /rev]
<b>100</b>	- 99,8 cm <sup>3</sup> /rev [ 6.09 in <sup>3</sup> /rev]
<b>125</b>	- 125,7 cm <sup>3</sup> /rev [ 7.67 in <sup>3</sup> /rev]
<b>160</b>	- 159,6 cm <sup>3</sup> /rev [ 9.74 in <sup>3</sup> /rev]
<b>200</b>	- 199,8 cm <sup>3</sup> /rev [12.19 in <sup>3</sup> /rev]
<b>250</b>	- 250,1 cm <sup>3</sup> /rev [15.26 in <sup>3</sup> /rev]
<b>315</b>	- 315,7 cm <sup>3</sup> /rev [19.26 in <sup>3</sup> /rev]
<b>400</b>	- 397,0 cm <sup>3</sup> /rev [24.40 in <sup>3</sup> /rev]

**Pos.3 - Shaft Extensions\*\***

- C** -  $\varnothing 25$  straight, Parallel key A8x7x30 DIN6885
- CO** -  $\varnothing 1$ " straight, Parallel key  $1/4$ "x $1/4$ "x $1 1/4$ " BS46
- SH** -  $\varnothing 25,3$  splined, BS 2059 (SAE 6B)
- K\*** - tapered 1:10, Woodruff key 6x9 DIN 6888
- CA\*** -  $\varnothing 1 1/4$ " straight, Parallel key  $5/16$ "x $5/16$ "x $1 1/4$ " Bs46
- CB\*** -  $\varnothing 32$  straight, Parallel key 10x8x40 DIN 6885

**Pos.4 - Shaft Seal Version**

- omit - Standard shaft seal
- U** - High pressure shaft seal (Not for **K, CA, CB** Shafts)

**Pos.5 - Tacho Connection\*\*\***

- omit - Without Tacho Connection
- T** - With Tacho Connection (Not for **Q** flange and **K, CA, CB** shafts)

**Pos.6 - Special Features** (see page 119)

**Pos.7 - Design Series**

- omit - Factory specified

**NOTES:**

- \* For "F"-flange only!
- \*\* The permissible output torque for shafts must not be exceeded!
- \*\*\* Radial or axial load on tacho shaft must be avoided. Max. torque on tacho shaft 0,1 daNm [.885 lb-in]. Max. cont. return pressure without drain line 20 bar [290 PSI].

For the Function Diagrams data please look at "M+S Hydraulic" Catalogue for MR motors, pages 35+39.

The hydraulic motors are manganese-phosphatized as standard.

# HYDRAULIC MOTORS MRNA



## APPLICATION

- » Actuator motor as driving-motor for steering mechanism of the the three-wheel vehicles;
- » For conveyors (series connection);
- » Dosing motor etc.

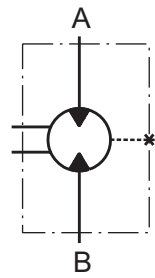

MRNA is suitable for driven mechanism where smooth operation low speed and high pressure is demanded. It is designed with separated output shaft and spool valve and can be specified with low internal leakage.

- » Good start-up characteristics;
- » Precise control of the Torque at low small flow.
- » Smooth operation at high pressure and small oil flow;
- » High volumetric efficiency.

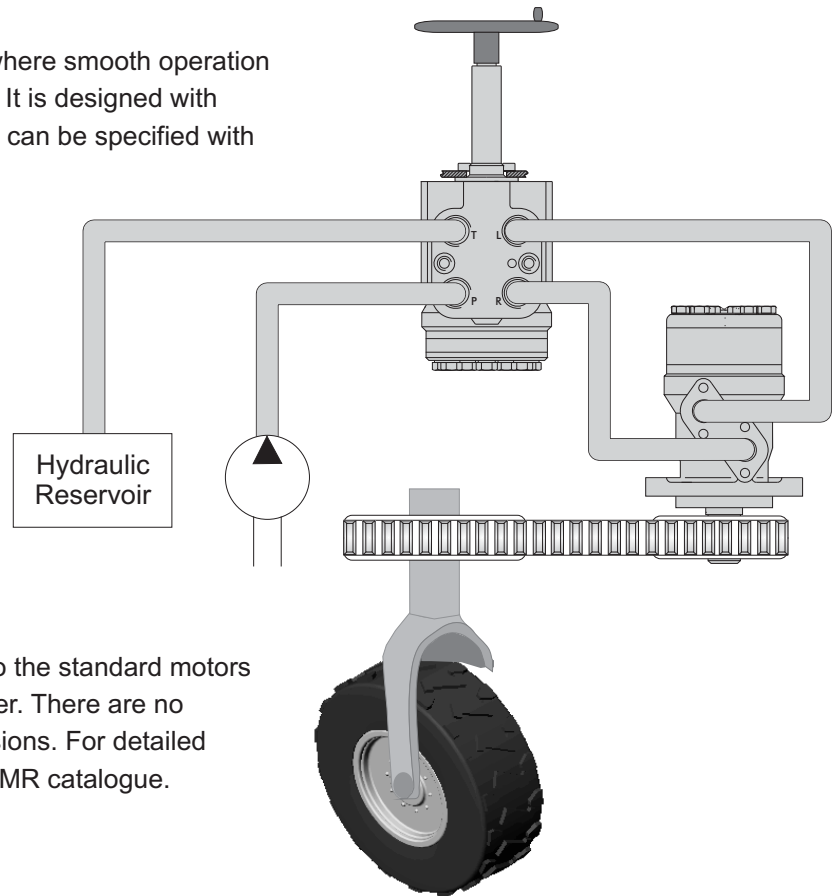

The main technical features correspond to the standard motors series MR  $\varnothing 28,56$  [1.124 in.] sealing diameter. There are no changes in the overall and mounting dimensions. For detailed technical and mounting data please refer to MR catalogue.

## SPECIFICATION DATA

Code	Displacement cm <sup>3</sup> /rev [in <sup>3</sup> /rev]	Max. Speed [RPM]	Max. Torque daNm [lb-in]				Max. Output kW [HP]				Max. Pressure Drop, bar [PSI]				Max. Oil Flow, lpm [GPM]
			C, CO shafts		SH, SA shafts		C, CO shafts		SH, SA shafts		C, CO shafts		SH, SA shafts		
			cont.	int*	cont.	int*	cont.	int*	cont.	int*	cont.	int*	cont.	int*	
MRNA 50	51,5 [3.14]	200	10 [885]	13 [1150]	10 [885]	13 [1150]	2,0 [2.68]	2,5 [3.35]	2,0 [2.68]	2,5 [3.35]	140 [2030]	175 [2540]	140 [2030]	175 [2540]	10,5 [2.8]
MRNA 80	80,3 [4.9]	200	20 [1770]	22 [1940]	20 [1770]	22 [1940]	3,0 [4.02]	3,5 [4.69]	3,0 [4.02]	3,5 [4.69]	175 [2540]	200 [2900]	175 [2540]	200 [2900]	16 [4.2]
MRNA 100	99,8 [6.09]	200	24 [2120]	28 [2480]	24 [2120]	28 [2480]	4,5 [6.03]	5,0 [6.71]	4,5 [6.03]	5,0 [6.71]	175 [2540]	200 [2900]	175 [2540]	200 [2900]	20 [5.3]
MRNA 125	125,7 [7.67]	200	30 [2650]	34 [3000]	30 [2650]	34 [3000]	5,5 [7.37]	6,0 [8.05]	5,5 [7.37]	6,0 [8.05]	175 [2540]	200 [2900]	175 [2540]	200 [2900]	25 [6.6]
MRNA 160	159,6 [9.74]	200	29 [2560]	39 [3450]	39 [3450]	43 [3800]	5,0 [6.71]	6,5 [8.05]	6,0 [8.05]	7,5 [10.05]	120 [1740]	175 [2540]	175 [2540]	200 [2900]	32 [8.5]
MRNA 200	199,8 [12.19]	200	29 [2560]	38,5 [3400]	38,5 [3400]	46 [4070]	5,0 [6.71]	7,0 [9.39]	6,5 [8.72]	9,0 [12.06]	105 [1520]	140 [2030]	140 [2030]	175 [2540]	40 [10.5]
MRNA 250	250,1 [15.26]	200	30 [2650]	39 [3450]	39 [3450]	47 [4160]	5,0 [6.71]	7,0 [9.39]	6,0 [8.05]	9,0 [12.06]	80 [1160]	110 [1600]	110 [1600]	140 [2030]	50 [13.2]
MRNA 315	315,7 [19.26]	190	30 [2650]	42 [3720]	36 [3450]	47 [4160]	5,0 [6.71]	7,5 [10.05]	6,0 [8.05]	8,5 [11.4]	70 [1020]	100 [1450]	85 [1230]	115 [1670]	65 [17.2]
MRNA 400	397,0 [24.4]	150	30 [2650]	40 [3540]	38 [3260]	47 [4160]	4,0 [5.36]	6,5 [8.72]	6,0 [8.05]	7,0 [9.39]	55 [800]	70 [1015]	65 [940]	90 [1300]	60 [15.8]

\* Intermittent operation: the permissible values may occur for max. 10% of every minute.

# HYDRAULIC MOTORS MRFL

The hydraulic motors type MRFL... and MLHRFL... are designed to be used in operating modes with peak radial loads of the output shaft (especially at starting and stopping) at direct drive of wheels or mechanisms (without clutch or gearbox).

The radial loads are borne by a radial ball bearing which is mounted on the shaft of the hydraulic motor.

The main technical features correspond to the standard motors series MRF  $\varnothing 35$  mm [1.378 in] sealing diameter. There are no changes in the overall and mounting dimensions. For detailed technical and mounting data please refer to MR catalogue.

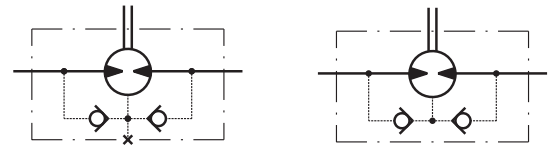

A  
Version D  
With Dust Seal

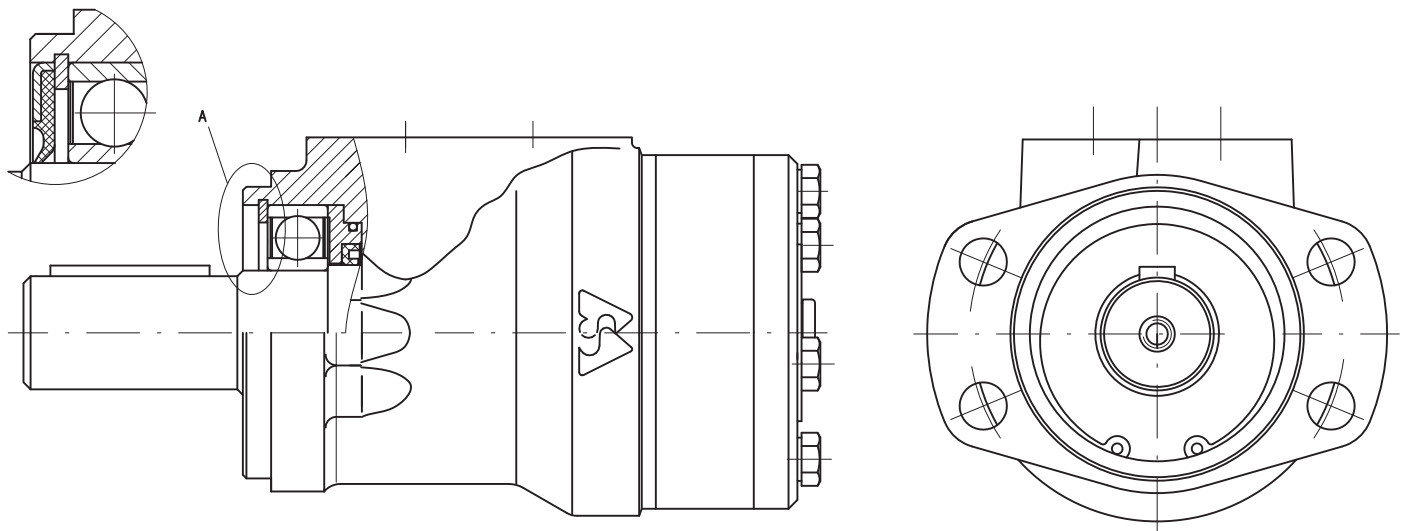

## PERMISSIBLE SHAFT LOADS

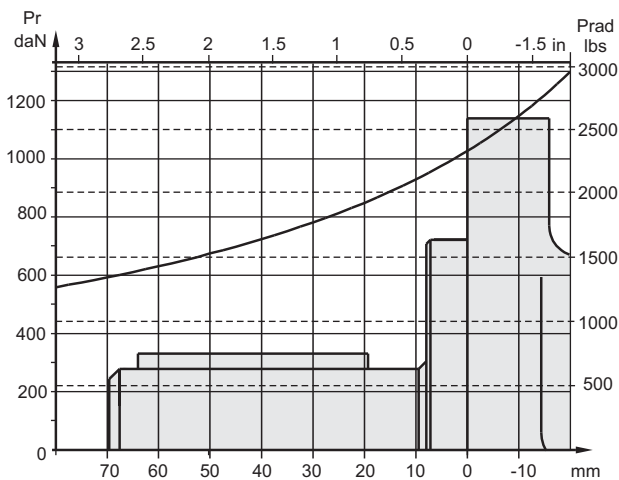

## MAX. PERMISSIBLE SHAFT SEAL PRESSURE

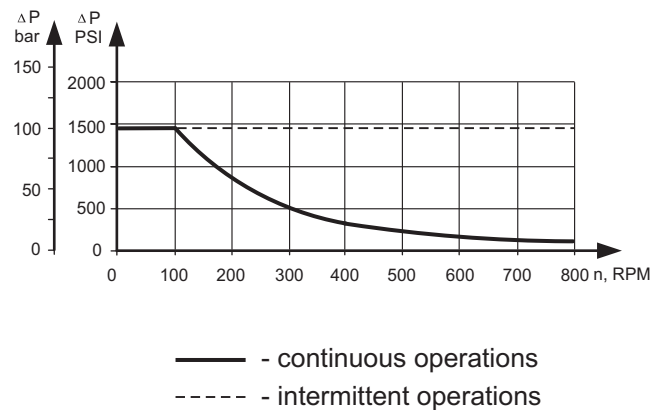

**ORDER CODE**

	1	2	3	4	5	6	7	8	9	10
<b>M R</b>										

**Pos.1 - Mounting Flange**

**F** - Oval mount, four holes

**Pos.2 - Option (bearings)**

**L** - with ball bearing

**Pos.3 - Port type**

omit - Side ports

**E** - Rear ports

**Pos.4 - Displacement code**

<b>50</b>	- 51,5 cm <sup>3</sup> /rev [ 3.14 in <sup>3</sup> /rev]
<b>80</b>	- 80,3 cm <sup>3</sup> /rev [ 4.90 in <sup>3</sup> /rev]
<b>100</b>	- 99,8 cm <sup>3</sup> /rev [ 6.09 in <sup>3</sup> /rev]
<b>125</b>	- 125,7 cm <sup>3</sup> /rev [ 7.67 in <sup>3</sup> /rev]
<b>160</b>	- 159,6 cm <sup>3</sup> /rev [ 9.74 in <sup>3</sup> /rev]
<b>200</b>	- 199,8 cm <sup>3</sup> /rev [12.19 in <sup>3</sup> /rev]
<b>250</b>	- 250,1 cm <sup>3</sup> /rev [15.26 in <sup>3</sup> /rev]
<b>315</b>	- 315,7 cm <sup>3</sup> /rev [19.26 in <sup>3</sup> /rev]
<b>400</b>	- 397,0 cm <sup>3</sup> /rev [24.40 in <sup>3</sup> /rev]

**Pos. 5 - Shaft Extensions\*(see page 28)**

**CB** - ø32 straight, Parallel key A10x8x45 DIN6885

**KB** - ø35 tapered 1:10, Parallel key B6x6x20 DIN6885

**SB** - splined A 25x22 DIN 5482

**OB** - ø1¼" tapered 1:8, Parallel key 5/16"x5/16"x1¼" BS46

**HB** - ø1¼" splined 14T ANSI B92.1 - 1976

**Pos. 6 - Dust Seal**

omit - without dust seal

**D** - with dust seal

**Pos. 7 - Drain Port**

omit - with drain port

**1** - without drain port

**Pos. 8 - Ports**

omit - BSPP (ISO 228)

**M** - Metric (ISO 262)

**Pos. 9 - Design Series**

omit - Factory specified

\* The permissible output torque for shafts must not be exceeded!

The hydraulic motors are mangano-phosphatized as standard.

# Hydraulic motors with Dual shaft type MRB...

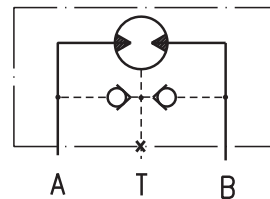

## OPTIONS

- » Model- Spool valve, roll-gerotor;
- » Dual shaft;
- » Oval flange;
- » Side port;
- » Straight shafts;
- » BSPP ports;
- » Other special features.

## APPLICATION

- » Conveyors;
- » Feeding mechanism of robots and manipulators;
- » Metal working machines;
- » Textile machines;
- » Agricultural machines;
- » Food industries;
- » Mining machinery etc.

## OUTLINE DIMENSINS REFERENCE

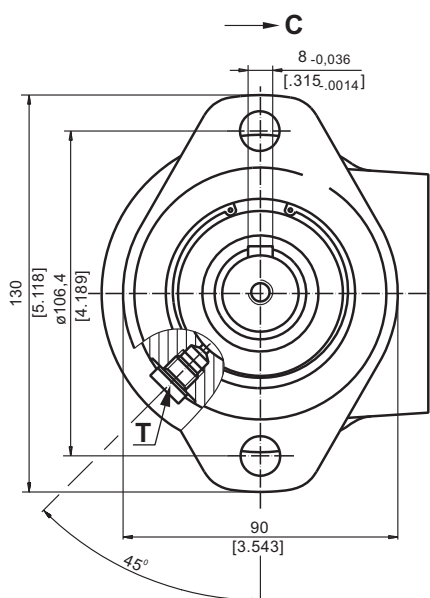
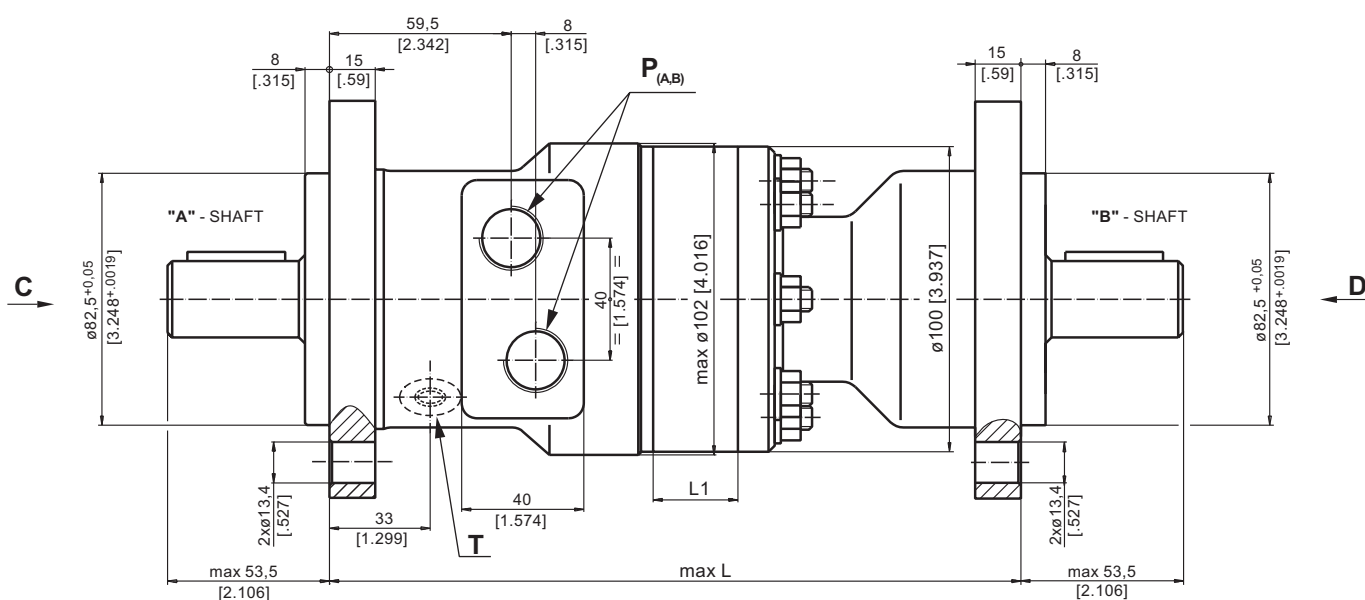

Type	L, mm [in]	L <sub>1</sub> , mm[in]
MRB 50	208,0 [8.19]	9,0 [.35]
MRB 80	213,0 [8.39]	14,0 [.55]
MRB 100	216,0 [8.50]	17,4 [.69]
MRB 125	220,5 [8.68]	21,8 [.86]
MRB 160	226,5 [8.92]	27,8 [1.09]
MRB 200	233,5 [9.19]	34,8 [1.37]
MRB 250	242,5 [9.55]	43,5 [1.71]
MRB 315	253,5 [9.98]	54,8 [2.16]
MRB 400	268,0 [10.55]	69,4 [2.73]

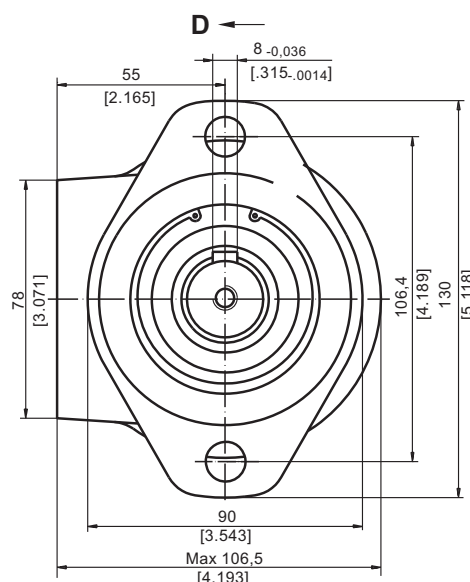

$P_{(A,B)}$ : 2xG1/2 - 18 mm [.71 in] depth  
 $T$  : G1/8 - 9 mm [.35 in] depth (plugged)



## SPECIFICATION DATA

Type	MRB 50 C/C	MRB 80 C/C	MRB 100 C/C	MRB 125 C/C	MRB 160 C/C	MRB 200 C/C	MRB 250 C/C	MRB 315 C/C	MRB 400 C/C
<b>Displacement, cm<sup>3</sup>/rev [in<sup>3</sup>/rev]</b>	51,5[3.14]	80,3[4.9]	99,8[6.09]	125,7[7.67]	159,6[9.74]	199,8[12.19]	250,1[15.26]	315,7[19.26]	397 [24.4]
<b>Max. Speed,</b>	775	750	600	475	375	300	240	190	150
<b>RPM</b>	970	940	750	600	470	375	300	240	190
<b>Max. Torque,</b>	10 [885]	19,5 [1725]	24 [2125]	30 [2655]	30 [2655]	30 [2655]	30 [2655]	30 [2655]	30 [2655]
<b>daNm [lb-in]</b>	13 [1150]	22 [1947]	28 [2480]	34 [3010]	39 [3450]	39 [3450]	38 [3360]	42 [3720]	43 [3805]
<b>Max. Torque "A" Shaft,</b>	8 [710]	11,5 [1000]	12 [1060]	20 [1770]	20 [1770]	20 [1770]	20 [1770]	20 [1770]	20 [1770]
<b>daNm [lb-in]</b>	9,5 [840]	13 [1150]	14 [1240]	23 [2035]	23 [2035]	23 [2035]	23 [2035]	23 [2035]	23 [2035]
<b>Max. Torque "B" Shaft,</b>	4 [355]	11,5 [1000]	12 [1060]	20 [1770]	20 [1770]	20 [1770]	20 [1770]	20 [1770]	20 [1770]
<b>daNm [lb-in]</b>	5 [440]	13 [1150]	14 [1240]	23 [2035]	23 [2035]	23 [2035]	23 [2035]	23 [2035]	23 [2035]
<b>Max. Output,</b>	7 [9.5]	12,5 [17]	13 [1150]	12,5 [17]	10 [13.4]	8 [10.7]	6 [8.0]	5 [6.7]	4 [5.4]
<b>[kW] [HP]</b>	8,5 [11.9]	15 [20.1]	15 [20.1]	14,5	12,5 [17]	10 [13.4]	8 [10.7]	6,5 [8.7]	6 [8.0]
<b>Max. Pressure Drop,</b>	140 [2030]	175 [2540]	175 [2540]	175 [2540]	130 [1885]	110 [1600]	80 [1160]	70 [1020]	55 [800]
<b>bar [PSI]</b>	175 [2540]	200 [2900]	200 [2900]	200 [2900]	175 [2540]	140 [2030]	110 [1600]	100 [1450]	80 [1160]
<b>Max. Oil Flow,</b>	40 [10.5]	60 [15.9]	60 [15.9]	60 [15.9]	60 [15.9]	60 [15.9]	60 [15.9]	60 [15.9]	60 [15.9]
<b>lpm [GPM]</b>	50 [13.2]	75 [18.5]	75 [18.5]	75 [18.5]	75 [18.5]	75 [18.5]	75 [18.5]	75 [18.5]	75 [18.5]
<b>Max. Return</b>	75 [1090]	75 [1090]	75 [1090]	75 [1090]	75 [1090]	75 [1090]	75 [1090]	75 [1090]	75 [1090]
<b>Pressure without</b>	50 [730]	50 [730]	50 [730]	50 [730]	50 [730]	50 [730]	50 [730]	50 [730]	50 [730]
<b>Drain Line, bar [PSI]</b>	20 [290]	20 [290]	20 [290]	20 [290]	20 [290]	20 [290]	20 [290]	20 [290]	20 [290]
	75 [1090]	75 [1090]	75 [1090]	75 [1090]	75 [1090]	75 [1090]	75 [1090]	75 [1090]	75 [1090]

\* Intermittent operation: the permissible values may occur for max. 10% of every minute.

1. Intermittent speed and intermittent pressure must not occur simultaneously.
2. Recommended filtration is per ISO cleanliness code 20/16. A nominal filtration of 25 micron or better.
3. Recommend using a premium quality, anti-wear type mineral based hydraulic oil HLP(DIN51524) or HM ( ISO 6743/4).  
If using synthetic fluids consult the factory for alternative seal materials.
4. Recommended minimum oil viscosity 13 mm<sup>2</sup>/s [70 SUS] at 50°C [122°F].
5. Recommended maximum system operating temperature is 82°C [180°F].
6. To assure optimum motor life fill with fluid prior to loading and run at moderate load and speed for 10-15 minutes.

**SHAFT EXTENSIONS**

**C** -  $\varnothing 25$  straight, Parallel key A8x7x30 DIN 6885  
Max. Torque 34 daNm [3010 lb-in]

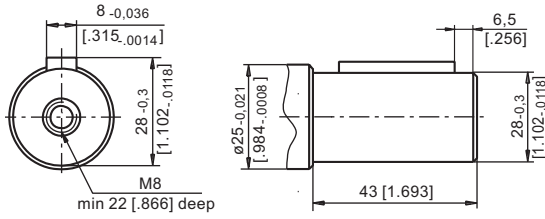

**SH** - 1" splined, BS 2059 (SAE 6B)  
Max. Torque 40 daNm [3540 lb-in]

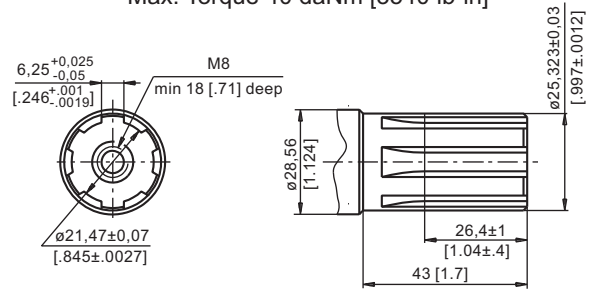

**PERMISSIBLE SHAFT LOADS**

The load diagrams are valid for an average bearings life of 1600 hrs at 200 r.p.m. with mineral base lubricating containing antiwear additives (ref.ISO 281 (3.3)standard).

The "A" curve gives the maximum static load affordable by the bearings.

The "B" curve gives the radial load top limit without axial load of 200 daN.

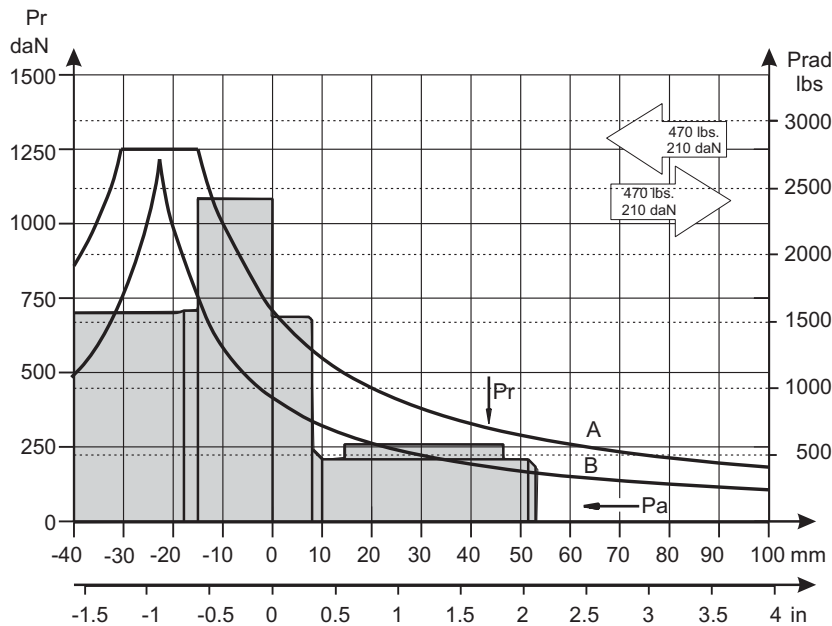

**ORDER CODE**

1	2	3	4	5
MRB		/		

Pos.1	Displacement code
50	- 51,5 cm <sup>3</sup> /rev [3.14 in <sup>3</sup> /rev]
80	- 80,3 cm <sup>3</sup> /rev [4.90 in <sup>3</sup> /rev]
100	- 99,8 cm <sup>3</sup> /rev [6.09 in <sup>3</sup> /rev]
125	- 125,7 cm <sup>3</sup> /rev [7.67 in <sup>3</sup> /rev]
160	- 159,6 cm <sup>3</sup> /rev [9.74 in <sup>3</sup> /rev]
200	- 199,8 cm <sup>3</sup> /rev [12.19 in <sup>3</sup> /rev]
250	- 250,1 cm <sup>3</sup> /rev [15.26 in <sup>3</sup> /rev]
315	- 315,7 cm <sup>3</sup> /rev [19.26 in <sup>3</sup> /rev]
400	- 397,0 cm <sup>3</sup> /rev [24.40 in <sup>3</sup> /rev]

Pos.2	"A" Shaft Extensions*
C	- $\varnothing 25$ straight, Parallel key A8x7x30 DIN6885
SH	- 1" splined, BS 2059 (SAE 6B)
Pos.3	"B" Shaft Extensions*
C	- $\varnothing 25$ straight, Parallel key A8x7x30 DIN6885
SH	- 1" splined, BS 2059 (SAE 6B)
Pos.4	Special Features (see page 119)
Pos.5	Design Series
omit	- Factory specified

**NOTES:** \* For other shaft extensions please contact with "M+S Hydraulic".  
\*\* Color at customer's request.

The hydraulic motors are mangano-phosphatized as standard.

# HYDRAULIC MOTORS PL

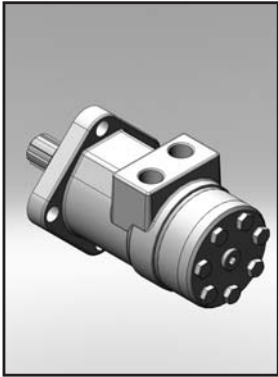

## APPLICATION

- » Conveyors
- » Feeding mechanism of robots and manipulators
- » Metal working machines
- » Textile machines
- » Agricultural machines
- » Food industries
- » Mining machinery etc.

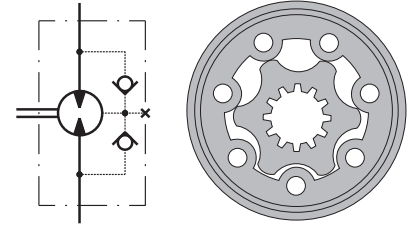

## CONTENTS

Specification data ..... 66  
 Dimensions and mounting .... 67  
 Shaft extensions ..... 68  
 Permissible shaft loads ..... 69  
 Order code ..... 69

## OPTIONS

- » Model - Spool valve, gerotor
- » Antifriction conical bearing
- » Flange mount
- » Shafts - straight, splined and tapered
- » Metric and BSPP ports
- » Other special features

## GENERAL

<b>Max Displacement,</b> cm <sup>3</sup> /rev [in <sup>3</sup> /rev]	396 [24.16]
<b>Max. Speed,</b> [RPM]	1515
<b>Max. Torque,</b> daNm [lb-in]	cont.: 50 [4415] int.: 59 [5222]
<b>Max. Output,</b> kW [HP]	17,5 [23.5]
<b>Max. Pressure Drop,</b> bar [PSI]	cont.: 140 [2030] int.: 175 [2540]
<b>Max. Oil Flow,</b> lpm [GPM]	75 [20]
<b>Min. Speed,</b> [RPM]	10
<b>Pressure fluid</b>	Mineral based- HLP(DIN 51524) or HM(ISO 6743/4)
<b>Temperature range,</b> °C [°F]	-40÷140 [-40÷284]
<b>Optimal Viscosity range,</b> mm <sup>2</sup> /s [SUS]	20÷75 [98÷347]
<b>Filtration</b>	ISO code 20/16 (Min. recommended fluid filtration of 25 microns)

### Oil flow in drain line

Pressure drop bar [PSI]	Viscosity mm <sup>2</sup> /s [SUS]	Oil flow in drain line lpm [GPM]
100 [1450]	20 [98]	2,5 [.660]
	35 [164]	1,8 [.476]
140 [2030]	20 [98]	3,5 [.925]
	35 [164]	2,8 [.740]

### Pressure Losses

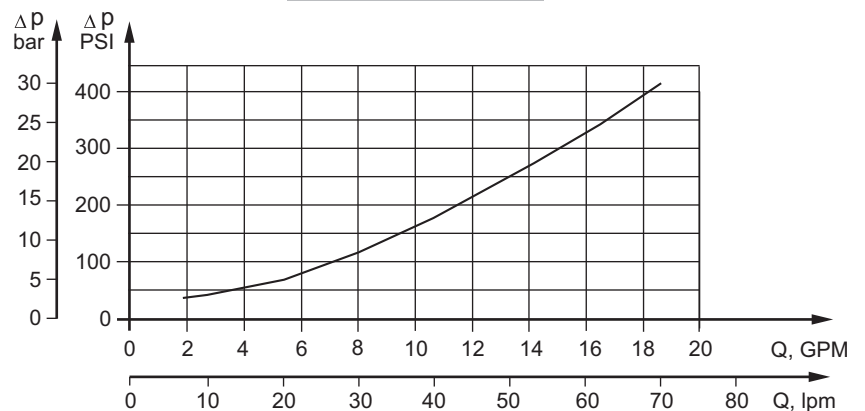

**SPECIFICATION DATA**

Type		PL 50	PL 80	PL 100	PL 125	PL 160	PL 200	PL 250	PL 315	PL 400
<b>Displacement, cm<sup>3</sup>/rev [in<sup>3</sup>/rev]</b>		49,5 [3.02]	79,2 [4.83]	99 [6.04]	123,8 [7.55]	158,4 [9.66]	198 [12.1]	247,5 [15.1]	316,8 [19.3]	396 [24.16]
<b>Max. Speed, [RPM]</b>	Cont.	1210	755	605	485	378	303	242	190	150
	Int.*	1515	945	755	605	472	378	303	236	189
<b>Max. Torque daNm [lb-in]</b>	Cont.	9,4 [832]	15,1 [1336]	19,3 [1708]	23,7 [2100]	31,3 [2770]	36,6 [3240]	47 [4160]	48,6 [4300]	50 [4425]
	Int.*	11,9 [1054]	19,5 [1725]	23,7 [2097]	29,8 [2637]	37,8 [3345]	45,6 [4035]	58,3 [5160]	56 [4956]	59 [5222]
	Peak**	14,0 [1240]	22,0 [1947]	27,0 [2390]	36,5 [3230]	42 [3717]	53 [4700]	67 [5930]	85 [7523]	85,4 [7560]
<b>Max. Output kW [HP]</b>	Cont.	9,9 [13.3]	9,9 [13.3]	9,9 [13.3]	9,9 [13.3]	11,7 [15.7]	10,3 [13.8]	9,8 [13.1]	7,6 [10.2]	6,6 [8.9]
	Int.*	12,5 [16.8]	12,5 [16.8]	12,5 [16.8]	12,5 [16.8]	12,5 [16.8]	12,5 [16.8]	12,5 [16.8]	10,5 [14]	8,5 [11.4]
<b>Max. Pressure Drop bar [PSI]</b>	Cont.	140 [2030]	140 [2030]	140 [2030]	140 [2030]	140 [2030]	140 [2030]	140 [2030]	120 [1300]	95 [1015]
	Int.*	175 [2540]	175 [2540]	175 [2540]	175 [2540]	175 [2540]	175 [2540]	175 [2540]	140 [2030]	115 [1665]
	Peak**	225 [3260]	225 [3260]	225 [3260]	225 [3260]	225 [3260]	225 [3260]	225 [3260]	225 [3260]	180 [2610]
<b>Max. Oil Flow lpm [GPM]</b>	Cont.	60 [16]	60 [16]	60 [16]	60 [16]	60 [16]	60 [16]	60 [16]	60 [16]	60 [16]
	Int.*	75 [20]	75 [20]	75 [20]	75 [20]	75 [20]	75 [20]	75 [20]	75 [20]	75 [20]
<b>Max. Inlet Pressure bar [PSI]</b>	Cont.	175 [2540]	175 [2540]	175 [2540]	175 [2540]	175 [2540]	175 [2540]	175 [2540]	175 [2540]	175 [2540]
	Int.*	200 [2900]	200 [2900]	200 [2900]	200 [2900]	200 [2900]	200 [2900]	200 [2900]	200 [2900]	200 [2900]
	Peak**	225 [3260]	225 [3260]	225 [3260]	225 [3260]	225 [3260]	225 [3260]	225 [3260]	225 [3260]	225 [3260]
<b>Max. Return Pressure without Drain Line or Max. Pressure in Drain Line, bar [PSI]</b>	Cont. 0-100 RPM	100 [1450]	100 [1450]	100 [1450]	100 [1450]	100 [1450]	100 [1450]	100 [1450]	100 [1450]	100 [1450]
	Cont. 100-300 RPM	50 [725]	50 [725]	50 [725]	50 [725]	50 [725]	50 [725]	50 [725]	50 [725]	50 [725]
	Cont. 300-600 RPM	25 [365]	25 [365]	25 [365]	25 [365]	25 [365]	25 [365]	25 [365]	25 [365]	25 [365]
	Cont. >600 RPM	15 [220]	15 [220]	15 [220]	15 [220]	15 [220]	15 [220]	15 [220]	15 [220]	15 [220]
	Int.* 0-max. RPM	100 [1450]	100 [1450]	100 [1450]	100 [1450]	100 [1450]	100 [1450]	100 [1450]	100 [1450]	100 [1450]
<b>Max. Return Pressure with Drain Line bar [PSI]</b>	Cont.	175 [2540]	175 [2540]	175 [2540]	175 [2540]	175 [2540]	175 [2540]	175 [2540]	175 [2540]	175 [2540]
	Int.*	200 [2900]	200 [2900]	200 [2900]	200 [2900]	200 [2900]	200 [2900]	200 [2900]	200 [2900]	200 [2900]
	Peak**	225 [3260]	225 [3260]	225 [3260]	225 [3260]	225 [3260]	225 [3260]	225 [3260]	225 [3260]	225 [3260]
<b>Max. Starting Pressure with Unloaded Shaft, bar [PSI]</b>		10 [145]	10 [145]	10 [145]	9 [131]	8 [116]	7 [100]	6 [87]	5 [73]	5 [73]
<b>Min. Starting Torque, daNm [lb-in]</b>		7,7 [681]	13 [1150]	16,8 [1487]	21,0 [1860]	28,0 [2478]	32,2 [2850]	41,4 [3665]	43,0 [3805]	44,0 [3900]
<b>Min. Speed***, [RPM]</b>		10	10	10	10	10	10	10	10	10
<b>Weight, kg [lb]</b>		6,8 [15]	7,0 [15.4]	7,1 [15.7]	7,2 [15.9]	7,4 [16.3]	7,6 [16.8]	7,8 [17.2]	8,2 [18]	8,6 [18.9]

\* Intermittent operation: the permissible values may occur for max. 10% of every minute.

\*\* Peak load: the permissible values may occur for max. 1% of every minute.

\*\*\* For speeds lower than given, consult factory or your regional manager.

- Intermittent speed and intermittent pressure must not occur simultaneously.
- Recommended filtration is per ISO cleanliness code 20/16. A nominal filtration of 25 micron or better.
- Recommend using a premium quality, anti-wear type mineral based hydraulic oil HLP(DIN51524) or HM ( ISO 6743/4).  
If using synthetic fluids consult the factory for alternative seal materials.
- Recommended minimum oil viscosity 13 mm<sup>2</sup>/s [70 SUS] at 50°C [122°F].
- Recommended maximum system operating temperature is 82°C [180°F].
- To assure optimum motor life fill with fluid prior to loading and run at moderate load and speed for 10-15 minutes.

**DIMENSIONS AND MOUNTING DATA**

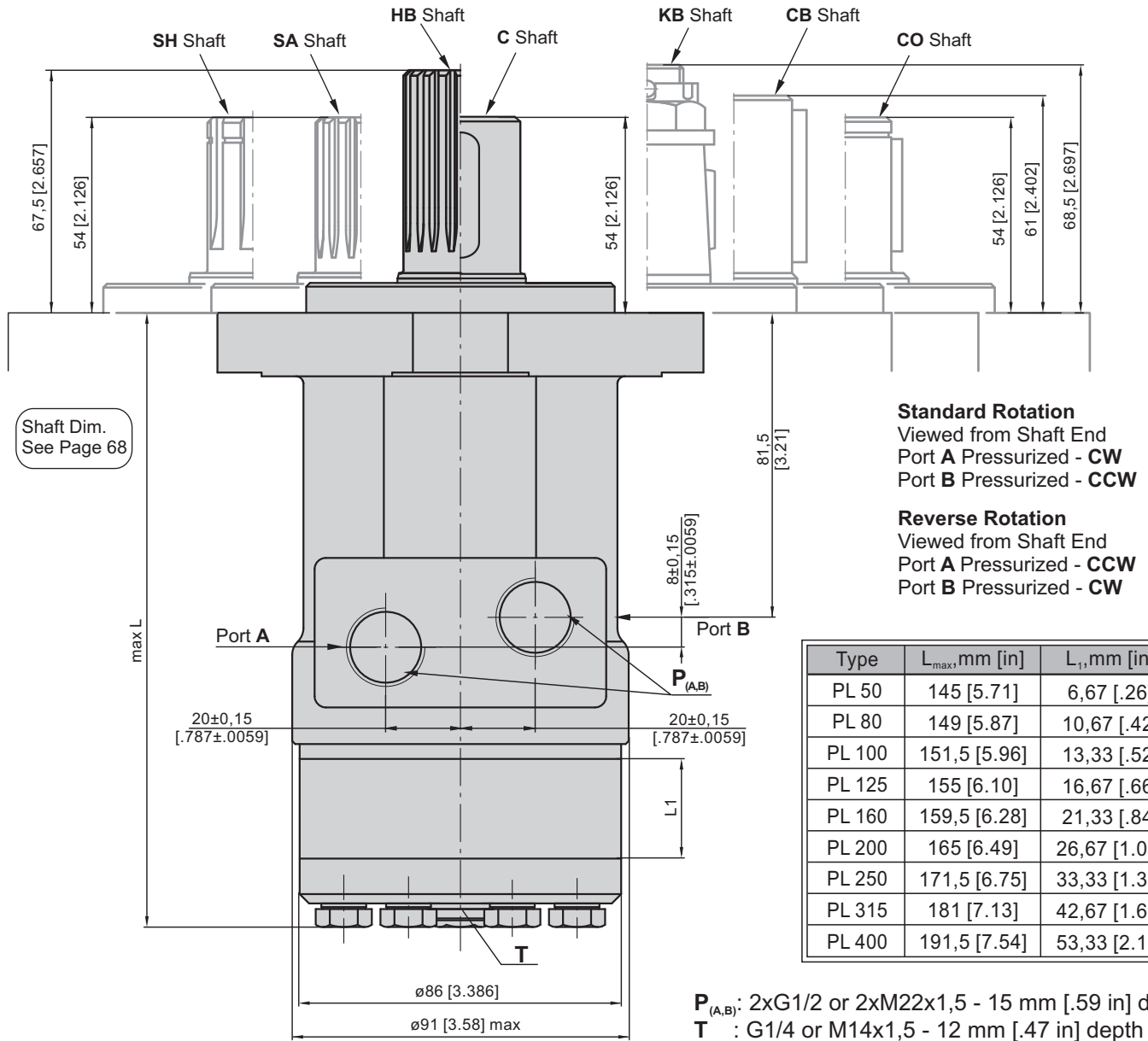

**MOUNTING**

Square Mount (4 Holes)

**F** Oval Mount (4 Holes)

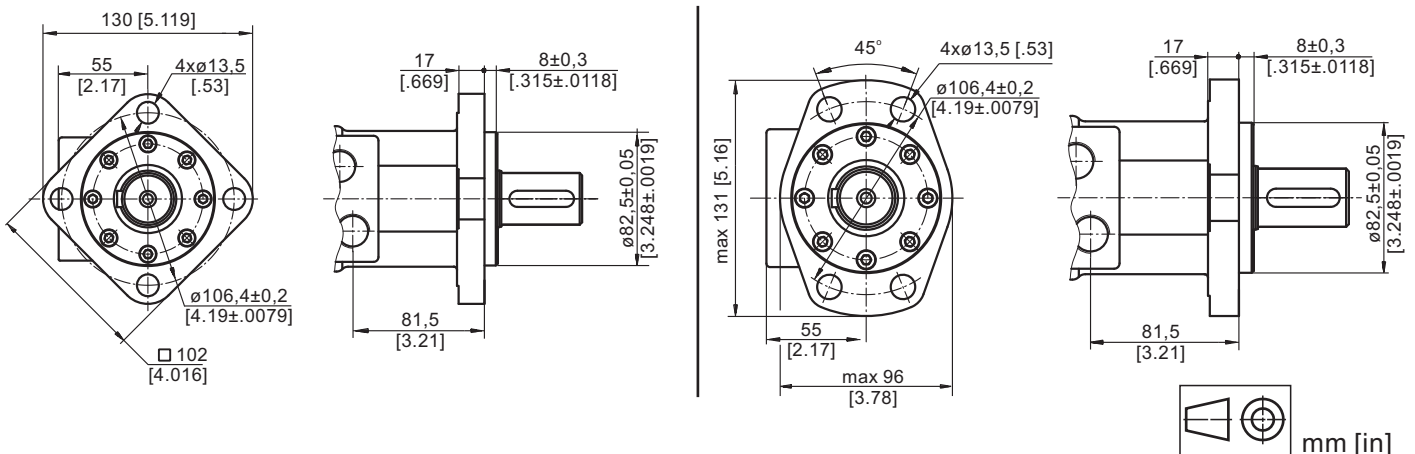

**SHAFT EXTENSIONS**

**C** -  $\varnothing 25$  straight, Parallel key A8x7x30 DIN 6885  
Max. Torque 34 daNm [3010 lb-in]

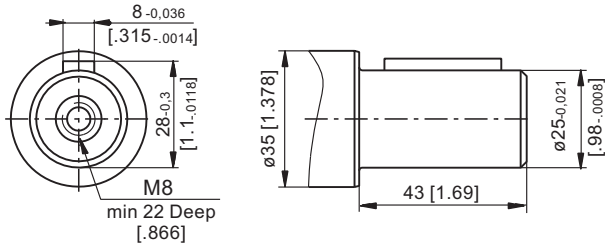

**SA** - splined B25x22 DIN 5482  
Max. Torque 40 daNm [3540 lb-in]

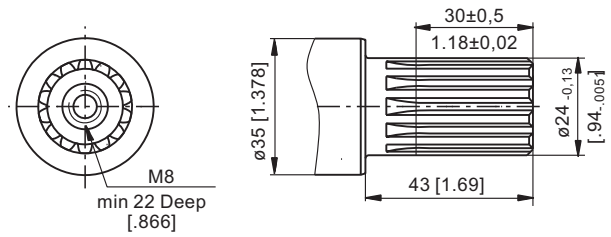

**CO** -  $\varnothing 1$ " straight, Parallel key 1/4"x1/4"x1/4" BS46  
Max. Torque 34 daNm [3010 lb-in]

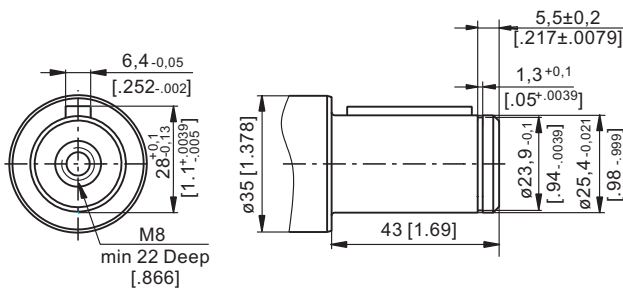

**CB** -  $\varnothing 32$  straight, Parallel key A10x8x40 DIN 6885  
Max. Torque 77 daNm [6815 lb-in]

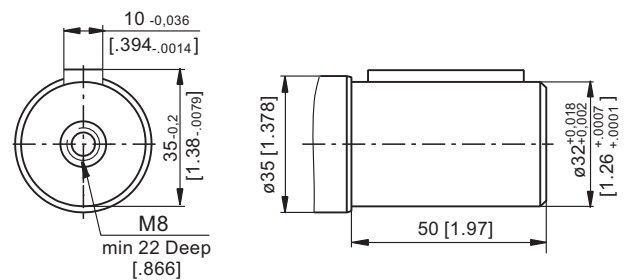

**SH** - splined, BS 2059 (SAE 6B)  
Max. Torque 40 daNm [3540 lb-in]

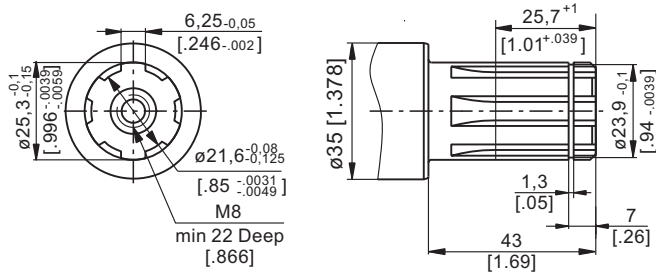

**HB** -  $\varnothing 1\frac{1}{4}$ " splined 14T, DP12/24 ANSI B92.1-1976  
Max. Torque 95 daNm [8410 lb-in]

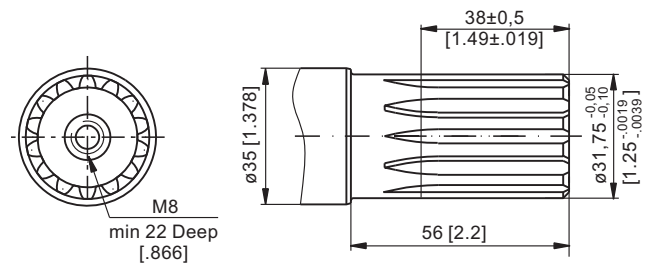

**KB** - tapered 1:10, Woodruff key 6x9 DIN6888  
Max. Torque 95 daNm [8410 lb-in]

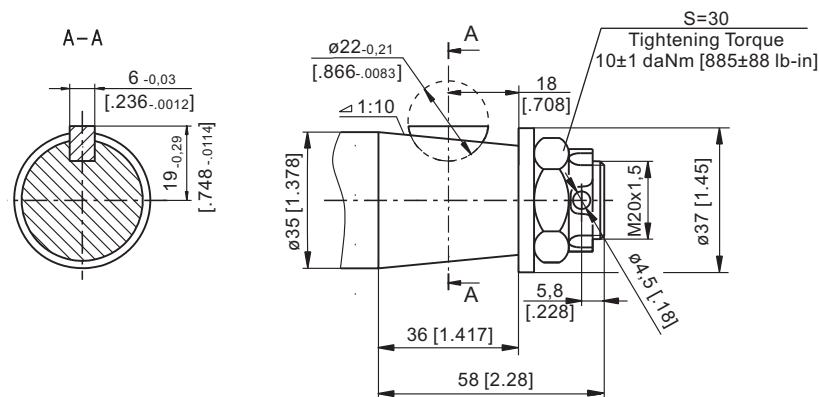

**Permissible Shaft Loads PL and RL**

The curves apply to a B10 bearings life of 2000 hrs

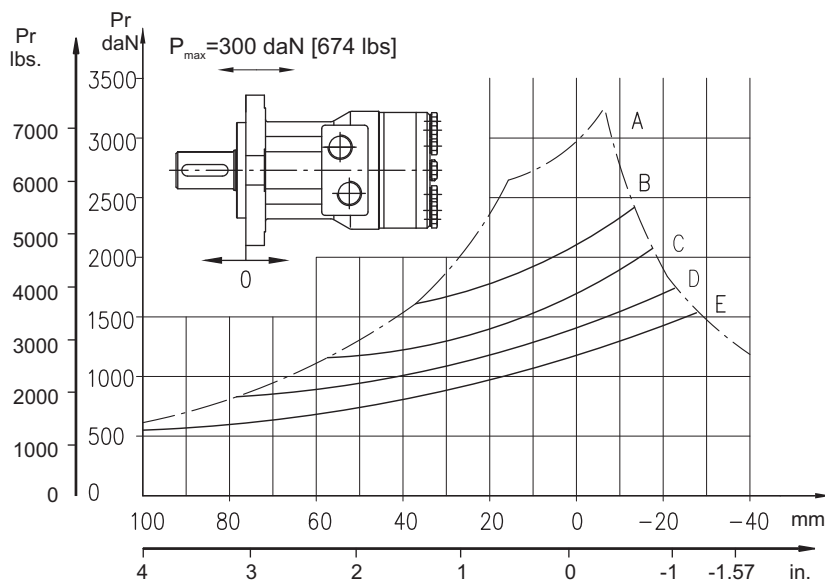

- A** - Max. radial shaft load.
- B** - n=50 min<sup>-1</sup>
- C** - n=100 min<sup>-1</sup>
- D** - n=200 min<sup>-1</sup>
- E** - n=400 min<sup>-1</sup>

**ORDER CODE**

	1	2	3	4	5	6	7
<b>PL</b>							

**Pos.1 - Mounting Flange**

omit - Square mount, four holes

**F** - Oval mount, four holes

**Pos.2 - Displacement code\***

<b>50</b>	- 49,5 cm <sup>3</sup> /rev [3.02 in <sup>3</sup> /rev]
<b>80</b>	- 79,2 cm <sup>3</sup> /rev [4.83 in <sup>3</sup> /rev]
<b>100</b>	- 99,0 cm <sup>3</sup> /rev [6.04 in <sup>3</sup> /rev]
<b>125</b>	- 123,8 cm <sup>3</sup> /rev [7.55 in <sup>3</sup> /rev]
<b>160</b>	- 158,4 cm <sup>3</sup> /rev [9.66 in <sup>3</sup> /rev]
<b>200</b>	- 198,0 cm <sup>3</sup> /rev [12.10 in <sup>3</sup> /rev]
<b>250</b>	- 247,5 cm <sup>3</sup> /rev [15.10 in <sup>3</sup> /rev]
<b>315</b>	- 316,8 cm <sup>3</sup> /rev [19.30 in <sup>3</sup> /rev]
<b>400</b>	- 396,0 cm <sup>3</sup> /rev [24.16 in <sup>3</sup> /rev]

**Pos.3 - Shaft Extensions\*\***

<b>C</b>	- ø25 straight, Parallel key A8x7x30 DIN6885
<b>CO</b>	- ø1" straight, Parallel key 1/4"x1/4"x1/4" BS46
<b>SH</b>	- ø25,3 splined, BS 2059 (SAE 6B)
<b>SA</b>	- ø24 splined, B 25x22 DIN 5482
<b>CB</b>	- ø32 straight, Parallel key A10x8x40 DIN6885
<b>HB</b>	- ø1 1/4" splined 14T ANSI B92.1-1976
<b>KB</b>	- ø35 tapered 1:10, Woodruff key 6x9 DIN6888

**Pos.4 - Shaft Seal Version**

omit - Standard shaft seal

**U** - High pressure shaft seal

**Pos.5 - Ports**

omit - BSPP (ISO 228)

**M** - Metric (ISO 262)

**Pos.6 - Special Features** (see page 119)

**Pos.7 - Design Series**

omit - Factory specified

**NOTES:**

\* For the Function Diagrams data please look at "M+S Hydraulic" Catalogue for MP motors, pages 19+23.

\*\* The permissible output torque for shafts must not be exceeded!

The hydraulic motors are manganophosphatized as standard.

# HYDRAULIC MOTORS RL

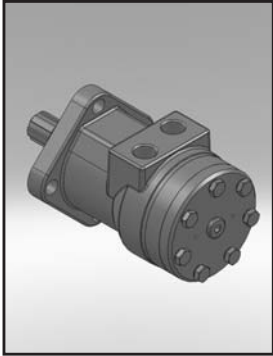

## APPLICATION

- » Conveyors
- » Feeding mechanism of robots and manipulators
- » Metal working machines
- » Textile machines
- » Agricultural machines
- » Food industries
- » Mining machinery etc.

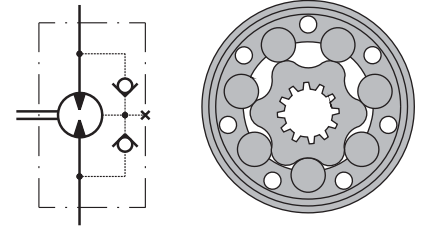

## CONTENTS

Specification data .....	71
Dimensions and mounting ....	72
Shaft extensions .....	73
Permissible shaft loads .....	74
Order code .....	74

## OPTIONS

- » Model - Spool valve, roll-gerotor
- » Antifriction conical bearings
- » Flange mount
- » Shafts - straight, splined and tapered
- » Metric and BSPP ports
- » Other special features

## GENERAL

<b>Max. Displacement,</b> cm <sup>3</sup> /rev. [in <sup>3</sup> /rev.]	397 [24.4]
<b>Max. Speed,</b> [RPM]	970
<b>Max. Torque,</b> daNm [lb-in]	cont.: 61 [5400] int.: 69 [6100]
<b>Max. Output,</b> kW [HP]	16 [21.5]
<b>Max. Pressure Drop,</b> bar [PSI]	cont.:175 [2540] int.: 200 [2900]
<b>Max. Oil Flow,</b> lpm [GPM]	75 [20]
<b>Min. Speed,</b> [RPM]	10
<b>Permissible Shaft Loads,</b> daN [lbs]	P <sub>a</sub> =500 [1124]
<b>Pressure fluid</b>	Mineral based- HLP(DIN 51524) or HM(ISO 6743/4)
<b>Temperature range,</b> °C [°F]	-40÷140 [-40÷284]
<b>Optimal Viscosity range,</b> mm <sup>2</sup> /s [SUS]	20÷75 [98÷347]
<b>Filtration</b>	ISO code 20/16 (Min. recommended fluid filtration of 25 microns)

### Oil flow in drain line

Pressure drop bar [PSI]	Viscosity mm <sup>2</sup> /s [SUS]	Oil flow in drain line lpm [GPM]
100 [1450]	20 [98]	2,5 [.660]
	35 [164]	1,8 [.476]
140 [2030]	20 [98]	3,5 [.925]
	35 [164]	2,8 [.740]

### Pressure Losses

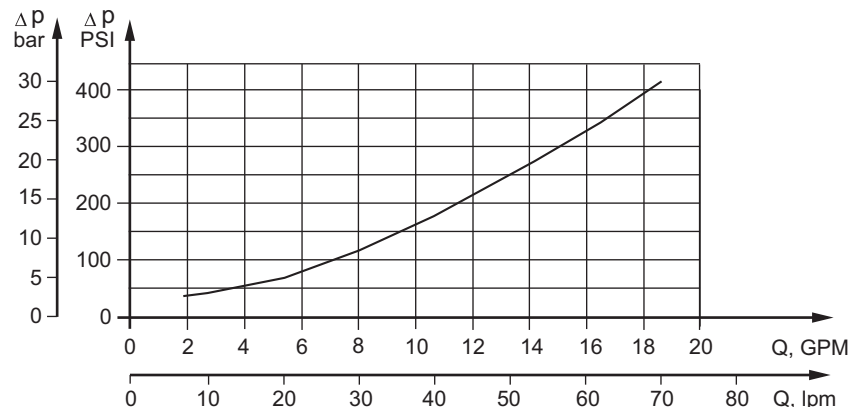

## SPECIFICATION DATA

Type		RL 50	RL 80	RL 100	RL 125	RL 160	RL 200	RL 250	RL 315	RL 400
<b>Displacement, cm<sup>3</sup>/rev [in<sup>3</sup>/rev]</b>		51,5 [3.14]	80,3 [4.90]	99,8 [6.09]	125,7 [7.67]	159,6 [9.74]	199,8[12.19]	250,1[15.26]	315,7[19.26]	397 [24.4]
<b>Max. Speed, [RPM]</b>	Cont.	775	750	600	475	375	300	240	190	150
	Int.*	970	940	750	600	470	375	300	240	190
<b>Max. Torque, daNm [lb-in]</b>	Cont.	10 [885]	19,5 [1725]	24 [2125]	30 [2655]	38 [3360]	45 [4000]	54 [4780]	55 [4870]	61 [5400]
	Int.*	13 [1150]	22 [1947]	28 [2480]	34 [3010]	43 [3805]	50 [4425]	61 [5400]	69 [6100]	69 [6100]
	Peak**	17 [1505]	27 [2390]	32 [2832]	37 [3275]	46 [4070]	56 [4960]	71 [6280]	84 [77430]	87 [7700]
<b>Max. Output kW [HP]</b>	Cont.	7 [9.5]	12,5 [17]	13 [17.4]	12,5 [16.8]	12,5 [16.8]	11 [14.8]	10 [13.4]	9 [12]	7,5 [10]
	Int.*	8,5 [11.9]	15 [20.1]	15 [20.1]	14,5 [19]	14 [18.8]	13 [17.4]	12 [16.1]	10 [13.4]	9 [12]
<b>Max. Pressure Drop bar [PSI]</b>	Cont.	140 [2030]	175 [2540]	175 [2540]	175 [2540]	175 [2540]	175 [2540]	175 [2540]	135 [1960]	110 [1600]
	Int.*	175 [2540]	200 [2900]	200 [2900]	200 [2900]	200 [2900]	200 [2900]	200 [2900]	175 [2540]	140 [2030]
	Peak**	225 [3260]	225 [3260]	225 [3260]	225 [3260]	225 [3260]	225 [3260]	225 [3260]	210 [3045]	175 [2540]
<b>Max. Oil Flow lpm [GPM]</b>	Cont.	40 [11]	60 [16]	60 [16]	60 [16]	60 [16]	60 [16]	60 [16]	60 [16]	60 [16]
	Int.*	50 [13]	75 [20]	75 [20]	75 [20]	75 [20]	75 [20]	75 [20]	75 [20]	75 [20]
<b>Max. Inlet Pressure bar [PSI]</b>	Cont.	175 [2540]	175 [2540]	175 [2540]	175 [2540]	175 [2540]	175 [2540]	175 [2540]	175 [2540]	175 [2540]
	Int.*	200 [2900]	200 [2900]	200 [2900]	200 [2900]	200 [2900]	200 [2900]	200 [2900]	200 [2900]	200 [2900]
	Peak**	225 [3260]	225 [3260]	225 [3260]	225 [3260]	225 [3260]	225 [3260]	225 [3260]	225 [3260]	225 [3260]
<b>Max. Return Pressure without Drain Line or Max. Pressure in Drain Line, bar [PSI]</b>	Cont. 0-100 RPM	100 [1450]	100 [1450]	100 [1450]	100 [1450]	100 [1450]	100 [1450]	100 [1450]	100 [1450]	100 [1450]
	Cont. 100-300 RPM	50 [725]	50 [725]	50 [725]	50 [725]	50 [725]	50 [725]	50 [725]	50 [725]	50 [725]
	Cont. 300-600 RPM	25 [365]	25 [365]	25 [365]	25 [365]	25 [365]	25 [365]	25 [365]	25 [365]	25 [365]
	Cont. >600 RPM	15 [220]	15 [220]	15 [220]	15 [220]	15 [220]	15 [220]	15 [220]	15 [220]	15 [220]
<b>Max. Return Pressure with Drain Line bar [PSI]</b>	Int.* 0-max. RPM	100 [1450]	100 [1450]	100 [1450]	100 [1450]	100 [1450]	100 [1450]	100 [1450]	100 [1450]	100 [1450]
	Cont.	140 [2030]	175 [2540]	175 [2540]	175 [2540]	175 [2540]	175 [2540]	175 [2540]	175 [2540]	175 [2540]
	Int.*	175 [2540]	200 [2900]	200 [2900]	200 [2900]	200 [2900]	200 [2900]	200 [2900]	200 [2900]	200 [2900]
<b>Min. Starting Torque daNm [lb-in]</b>	Peak**	225 [3260]	225 [3260]	225 [3260]	225 [3260]	225 [3260]	225 [3260]	225 [3260]	225 [3260]	225 [3260]
<b>Max. Starting Pressure with Unloaded Shaft, bar [PSI]</b>		10 [145]	10 [145]	10 [145]	9 [130]	7 [102]	5 [73]	5 [73]	5 [73]	5 [73]
<b>Min. Speed***, [RPM]</b>		8 [710]	15 [1330]	20 [1770]	25 [2215]	32 [2835]	37 [3275]	45 [3983]	45 [3983]	49 [4335]
<b>Weight, kg [lb]</b>		10	10	10	10	10	10	10	10	10
		7,7 [17]	7,8 [17.2]	8,1 [17.8]	8,2 [18]	8,4 [18.5]	8,9 [19.6]	9,3 [20.5]	10,0 [22]	10,7 [23.6]

\* Intermittent operation: the permissible values may occur for max. 10% of every minute.

\*\* Peak load: the permissible values may occur for max. 1% of every minute.

\*\*\* For speeds lower than given, consult factory or your regional manager.

- Intermittent speed and intermittent pressure must not occur simultaneously.
- Recommended filtration is per ISO cleanliness code 20/16. A nominal filtration of 25 micron or better.
- Recommend using a premium quality, anti-wear type mineral based hydraulic oil HLP(DIN51524) or HM ( ISO 6743/4). If using synthetic fluids consult the factory for alternative seal materials.
- Recommended minimum oil viscosity 13 mm<sup>2</sup>/s [70 SUS] at 50°C [122°F].
- Recommended maximum system operating temperature is 82°C [180°F].
- To assure optimum motor life fill with fluid prior to loading and run at moderate load and speed for 10-15 minutes.

**DIMENSIONS AND MOUNTING DATA**

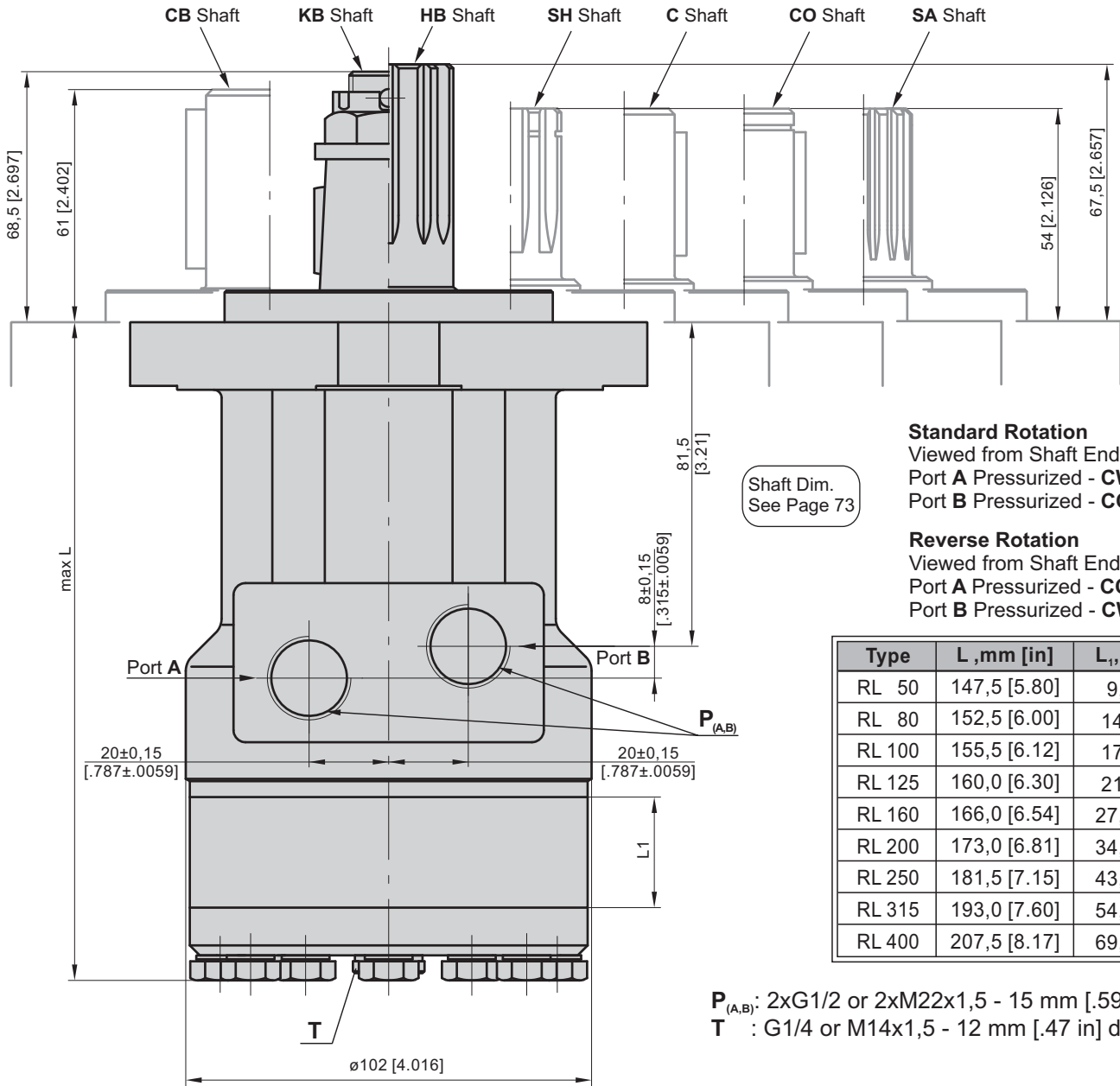

Shaft Dim.  
See Page 73

**Standard Rotation**

Viewed from Shaft End  
Port A Pressurized - CW  
Port B Pressurized - CCW

**Reverse Rotation**

Viewed from Shaft End  
Port A Pressurized - CCW  
Port B Pressurized - CW

Type	L ,mm [in]	L <sub>1</sub> ,mm [in]
RL 50	147,5 [5.80]	9,0 [.35]
RL 80	152,5 [6.00]	14,0 [.55]
RL 100	155,5 [6.12]	17,4 [.69]
RL 125	160,0 [6.30]	21,8 [.86]
RL 160	166,0 [6.54]	27,8 [1.09]
RL 200	173,0 [6.81]	34,8 [1.37]
RL 250	181,5 [7.15]	43,5 [1.71]
RL 315	193,0 [7.60]	54,8 [2.16]
RL 400	207,5 [8.17]	69,4 [2.73]

P<sub>(A,B)</sub>: 2xG1/2 or 2xM22x1,5 - 15 mm [.59 in] depth  
T : G1/4 or M14x1,5 - 12 mm [.47 in] depth



**MOUNTING**

**Square Mount (4 Holes)**

**F Oval Mount (4 Holes)**

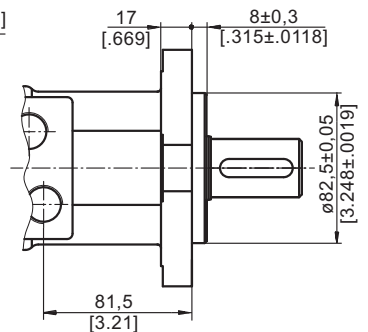
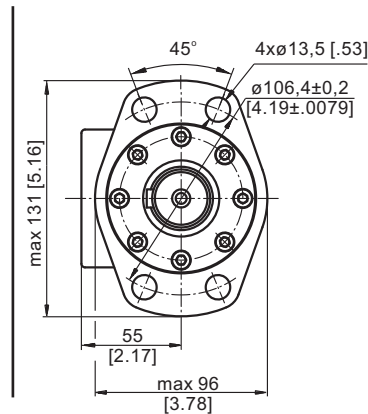
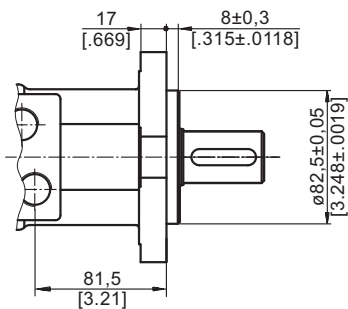
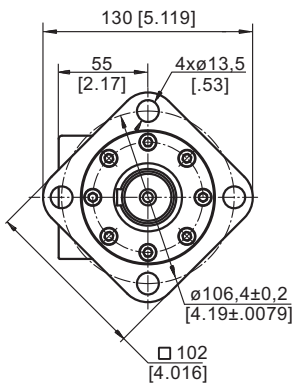

**SHAFT EXTENSIONS**

**C** -  $\varnothing 25$  straight, Parallel key A8x7x30 DIN 6885  
Max. Torque 34 daNm [3010 lb-in]

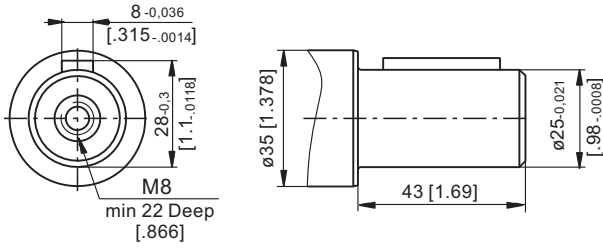

**SA** - splined B25x22 DIN 5482  
Max. Torque 40 daNm [3540 lb-in]

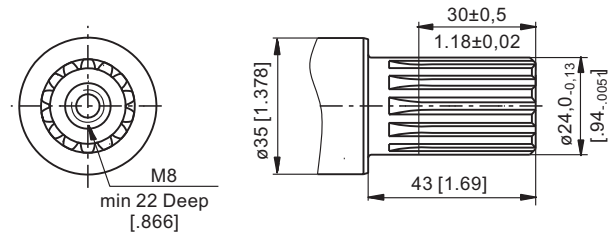

**CO** -  $\varnothing 1"$  straight, Parallel key 1/4"x1/4"x1/4" BS46  
Max. Torque 34 daNm [3010 lb-in]

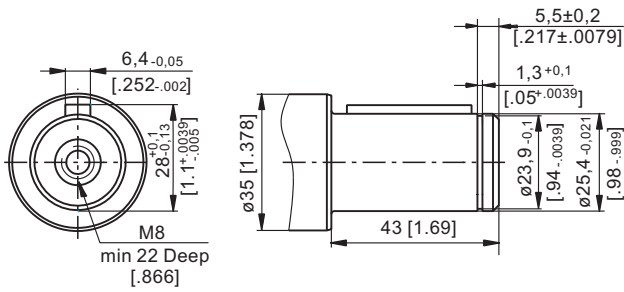

**CB** -  $\varnothing 32$  straight, Parallel key A10x8x40 DIN 6885  
Max. Torque 77 daNm [6815 lb-in]

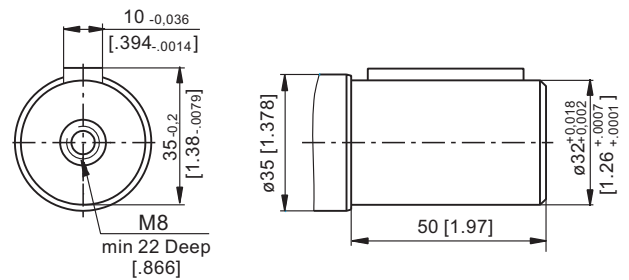

**SH** - splined, BS 2059 (SAE 6B)  
Max. Torque 40 daNm [3540 lb-in]

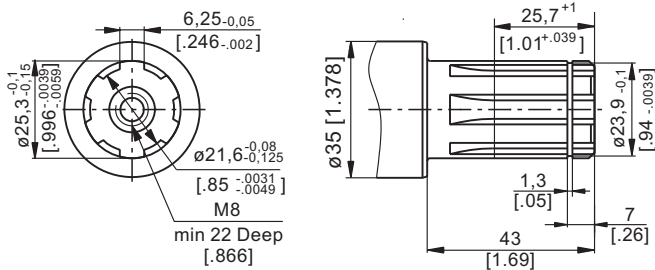

**HB** -  $\varnothing 1\frac{1}{4}"$  splined 14T, DP12/24 ANSI B92.1-1976  
Max. Torque 95 daNm [8410 lb-in]

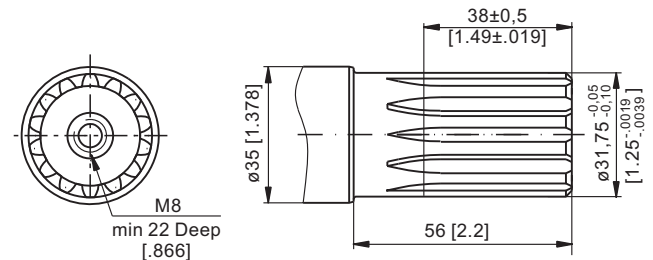

**KB** - tapered 1:10, Woodruff key 6x9 DIN6888  
Max. Torque 95 daNm [8410 lb-in]

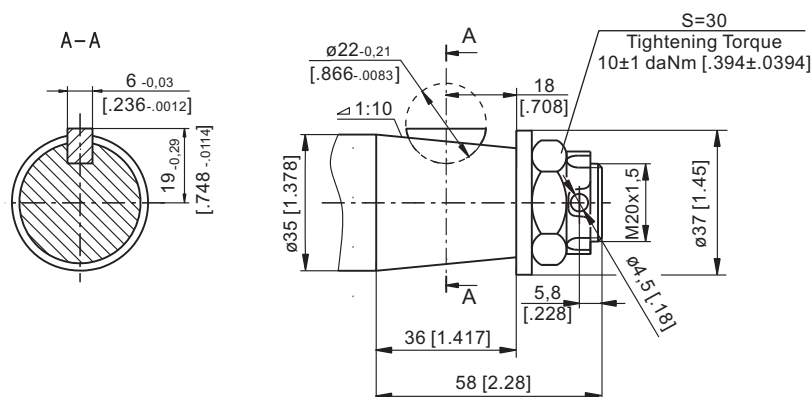

**Permissible Shaft Loads PL and RL**

The curves apply to a B10 bearings life of 2000 hrs

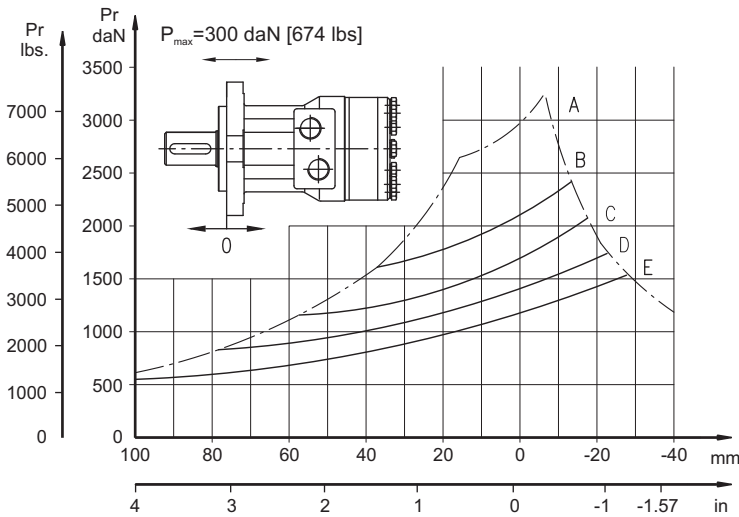

- A** - Max. radial shaft load.
- B** -  $n=50 \text{ min}^{-1}$
- C** -  $n=100 \text{ min}^{-1}$
- D** -  $n=200 \text{ min}^{-1}$
- E** -  $n=400 \text{ min}^{-1}$

**MAX. PERMISSIBLE SHAFT SEAL PRESSURE**

Max return pressure without drain line or max. pressure in drain line

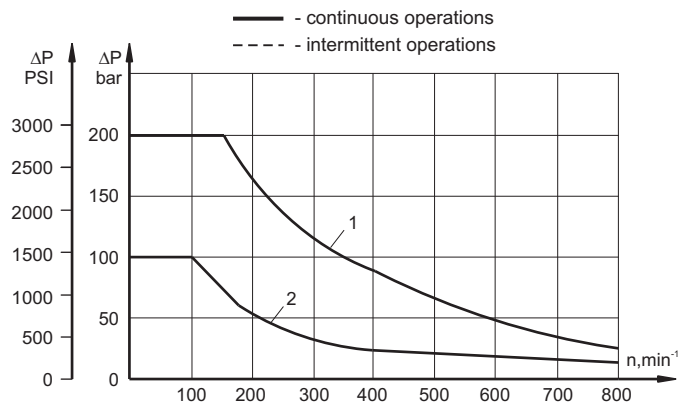

**ORDER CODE**

	1	2	3	4	5	6
<b>RL</b>						

**Pos.1 - Mounting Flange**

- omit - Square mount, four holes
- F** - Oval mount, four holes

**Pos.2 - Displacement code\***

<b>50</b>	- 51,5 cm <sup>3</sup> /rev [3.14 in <sup>3</sup> /rev]
<b>80</b>	- 80,3 cm <sup>3</sup> /rev [4.90 in <sup>3</sup> /rev]
<b>100</b>	- 99,8 cm <sup>3</sup> /rev [6.09 in <sup>3</sup> /rev]
<b>125</b>	- 125,7 cm <sup>3</sup> /rev [7.67 in <sup>3</sup> /rev]
<b>160</b>	- 159,6 cm <sup>3</sup> /rev [9.74 in <sup>3</sup> /rev]
<b>200</b>	- 199,8 cm <sup>3</sup> /rev [12.19 in <sup>3</sup> /rev]
<b>250</b>	- 250,1 cm <sup>3</sup> /rev [15.26 in <sup>3</sup> /rev]
<b>315</b>	- 315,7 cm <sup>3</sup> /rev [19.26 in <sup>3</sup> /rev]
<b>400</b>	- 397,0 cm <sup>3</sup> /rev [24.40 in <sup>3</sup> /rev]

**Pos.3 - Shaft Extensions\*\***

- C** -  $\varnothing 25$  straight, Parallel key A8x7x35 DIN6885
- CO** -  $\varnothing 1$ " straight, Parallel key  $\frac{1}{4} \times \frac{1}{4} \times 1 \frac{1}{4}$ " BS46
- SH** -  $\varnothing 25,3$  splined, BS 2059 (SAE 6B)
- SA** -  $\varnothing 24$  splined, B 25x22 DIN 5482
- CB** -  $\varnothing 32$  straight, Parallel key A10x8x40 DIN6885
- HB** -  $\varnothing 1 \frac{1}{4}$ " splined 14T ANSI B92.1-1976
- KB** -  $\varnothing 35$  tapered 1:10, Woodruff key 6x9 DIN6888

**Pos.4 - Shaft Seal Version**

- omit - Standard shaft seal
- U** - High pressure shaft seal

**Pos.4 - Ports**

- omit - BSPP (ISO 228)
- M** - Metric (ISO 262)

**Pos.5 - Special Features (see page 119)**

**Pos.6 - Design Series**

- omit - Factory specified

**NOTES:**

- \* For the Function Diagrams data please look at "M+S Hydraulic" Catalogue for MR motors, pages 35+39.
- \*\* The permissible output torque for shafts must not be exceeded!  
The hydraulic motors are manganese-phosphatized as standard.

# HYDRAULIC MOTORS PK



## APPLICATION

- » Conveyors
- » Feeding mechanism of robots and manipulators
- » Metal working machines
- » Textile machines
- » Agricultural machines
- » Food industries
- » Mining machinery etc.

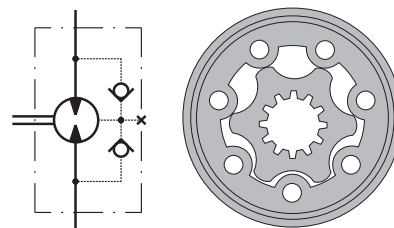

## CONTENTS

Specification data ..... 76  
 Dimensions and mounting ... 77  
 Shaft extensions ..... 78  
 Order code ..... 78

## OPTIONS

- » Model - Spool valve, gerotor
- » Antifriction conical bearing
- » Flange mount
- » Shafts - straight, splined and tapered
- » Metric and BSPP ports
- » Other special features

## GENERAL

<b>Max. Displacement,</b> cm <sup>3</sup> /rev [in <sup>3</sup> /rev]	396 [24.16]
<b>Max. Speed,</b> [RPM]	1010
<b>Max. Torque,</b> daNm [lb-in]	cont.: 40,8 [3611] int.: 55,6 [4921]
<b>Max. Output,</b> kW [HP]	8,6 [11.5]
<b>Max. Pressure Drop,</b> bar [PSI]	cont.: 105 [1520] int.: 140 [2030]
<b>Max. Oil Flow,</b> lpm [GPM]	50 [13.2]
<b>Min. Speed,</b> [RPM]	10
<b>Pressure fluid</b>	Mineral based- HLP(DIN 51524) or HM(ISO 6743/4)
<b>Temperature range,</b> °C [°F]	-40÷140 [-40÷284]
<b>Optimal Viscosity range,</b> mm <sup>2</sup> /s [SUS]	20÷75 [98÷347]
<b>Filtration</b>	ISO code 20/16 (Min. recommended fluid filtration of 25 microns)

### Oil flow in drain line

Pressure drop bar [PSI]	Viscosity mm <sup>2</sup> /s [SUS]	Oil flow in drain line lpm [GPM]
100 [1450]	20 [98]	2,5 [.660]
	35 [164]	1,8 [.476]
140 [2030]	20 [98]	3,5 [.925]
	35 [164]	2,8 [.740]

### Pressure Losses

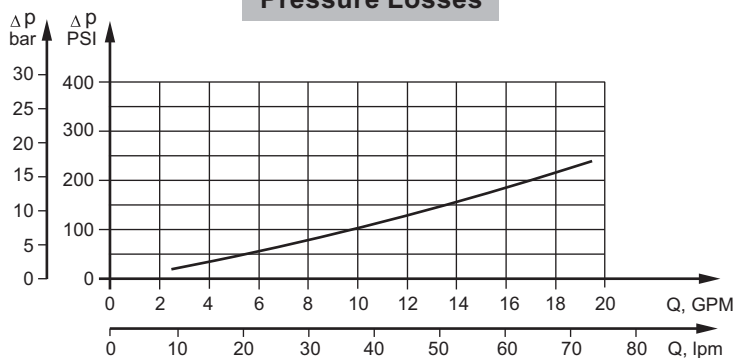

## SPECIFICATION DATA

Type	PK 50	PK 80	PK 100	PK 125	PK 160	PK 200	PK 250	PK 315	PK 400	
<b>Displacement, cm<sup>3</sup>/rev [in<sup>3</sup>/rev]</b>	49,5[3.02]	79,2 [4.83]	99 [6.04]	123,8 [7.55]	158,4 [966]	198 [12.1]	247,5 [15.1]	316,8 [19.3]	396 [24.16]	
<b>Max. Speed, [RPM]</b>	Cont.	808	505	404	323	252	202	160	100	
	Int.*	1010	630	505	403	315	252	202	126	
<b>Max. Torque daNm [lb-in]</b>	Cont.	7 [619]	10,8 [956]	14,4 [1274]	17 [1504]	22 [1974]	27,5 [2434]	30,1 [2664]	31,7 [2805]	40,8 [3611]
	Int.*	9,2 [814]	14,6 [1292]	18,3 [1619]	22,9 [2026]	29,3 [2593]	36,6 [3239]	37,6 [3328]	44 [3894]	55,6 [4921]
	Peak**	13,6 [1203]	21,4 [1894]	26,1 [2310]	32,6 [2885]	41,8 [3700]	52,2 [4620]	51,5 [4558]	64,3 [5691]	80 [7080]
<b>Max. Output kW [HP]</b>	Cont.	5,2 [7.0]	5,2 [7.0]	5,2 [7.0]	5,2 [7.0]	5,2 [7.0]	5,2 [7.0]	4,6 [6.2]	3,4 [4.6]	3,4 [4.6]
	Int.*	8,6 [11.5]	8,6 [11.5]	8,6 [11.5]	8,6 [11.5]	8,6 [11.5]	8,6 [11.5]	7 [9.3]	5,8 [7.8]	5,8 [7.8]
<b>Max. Pressure Drop bar [PSI]</b>	Cont.	105 [1520]	105 [1520]	105 [1520]	105 [1520]	105 [1520]	105 [1520]	90 [1305]	70 [1015]	70 [1015]
	Int.*	140 [2030]	140 [2030]	140 [2030]	140 [2030]	140 [2030]	140 [2030]	115 [1665]	105 [1520]	105 [1520]
	Peak**	215 [3120]	215 [3120]	215 [3120]	215 [3120]	215 [3120]	215 [3120]	170 [2470]	170 [2470]	170 [2470]
<b>Max. Oil Flow lpm [GPM]</b>	Cont.	40 [10.5]	40 [10.5]	40 [10.5]	40 [10.5]	40 [10.5]	40 [10.5]	40 [10.5]	40 [10.5]	40 [10.5]
	Int.*	50 [13.2]	50 [13.2]	50 [13.2]	50 [13.2]	50 [13.2]	50 [13.2]	50 [13.2]	50 [13.2]	50 [13.2]
<b>Max. Inlet Pressure bar [PSI]</b>	Cont.	140 [2030]	140 [2030]	140 [2030]	140 [2030]	140 [2030]	140 [2030]	140 [2030]	140 [2030]	140 [2030]
	Int.*	175 [2540]	175 [2540]	175 [2540]	175 [2540]	175 [2540]	175 [2540]	175 [2540]	175 [2540]	175 [2540]
	Peak**	225 [3260]	225 [3260]	225 [3260]	225 [3260]	225 [3260]	225 [3260]	225 [3260]	225 [3260]	225 [3260]
<b>Max. Return Pressure with Drain Line or Max. Pressure in Drain Line, bar [PSI]</b>	Cont. 0-100 RPM	150 [2180]	150 [2180]	150 [2180]	150 [2180]	150 [2180]	150 [2180]	150 [2180]	150 [2180]	150 [2180]
	Cont. 100-300 RPM	75 [1090]	75 [1090]	75 [1090]	75 [1090]	75 [1090]	75 [1090]	75 [1090]	75 [1090]	75 [1090]
	Cont. 300-600 RPM	50 [725]	50 [725]	50 [725]	50 [725]	50 [725]	50 [725]	50 [725]	50 [725]	50 [725]
	Cont. >600 RPM	20 [290]	20 [290]	20 [290]	20 [290]	20 [290]	20 [290]	20 [290]	20 [290]	20 [290]
	Int.* 0-max. RPM	15 [220]	15 [220]	15 [220]	15 [220]	15 [220]	15 [220]	15 [220]	15 [220]	15 [220]
<b>Max. Starting Pressure with Unloaded Shaft, bar [PSI]</b>	10 [145]	10 [145]	10 [145]	10 [145]	10 [145]	10 [145]	10 [145]	10 [145]	10 [145]	
<b>Min. Starting Torque, daNm [lb-in]</b>	5,8 [513]	9,1 [805]	12,2 [1079]	14,5 [1283]	19,5 [1725]	24,8 [2195]	27,5 [2433]	29 [2567]	35,9 [3278]	
<b>Min. Speed***, [RPM]</b>	10	10	10	10	10	10	10	10	10	
<b>Weight, kg [lb]</b>	5 [11.1]	5,1 [11.2]	5,3 [11.7]	5,4 [11.9]	5,6 [12.3]	5,8 [12.8]	6 [13.2]	6,3 [13.9]	6,8 [15]	

\* Intermittent operation: the permissible values may occur for max. 10% of every minute.

\*\* Peak load: the permissible values may occur for max. 1% of every minute.

\*\*\* For speeds lower than given, consult factory or your regional manager.

- Intermittent speed and intermittent pressure must not occur simultaneously.
- Recommended filtration is per ISO cleanliness code 20/16. A nominal filtration of 25 micron or better.
- Recommend using a premium quality, anti-wear type mineral based hydraulic oil HLP(DIN51524) or HM ( ISO 6743/4).  
If using synthetic fluids consult the factory for alternative seal materials.
- Recommended minimum oil viscosity 13 mm<sup>2</sup>/s [70 SUS] at 50°C [122°F].
- Recommended maximum system operating temperature is 82°C [180°F].
- To assure optimum motor life fill with fluid prior to loading and run at moderate load and speed for 10-15 minutes.

**DIMENSIONS AND MOUNTING DATA**

**PK**

**PKQ**

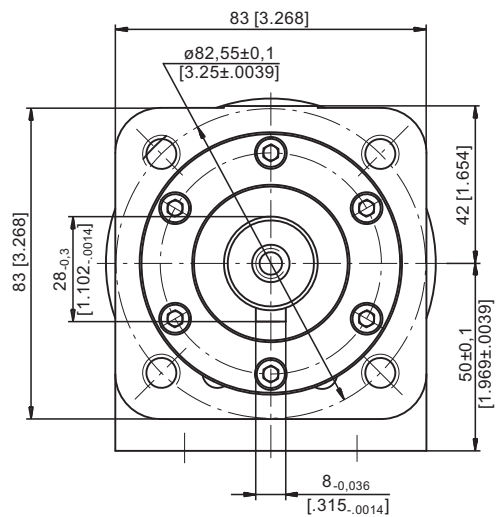
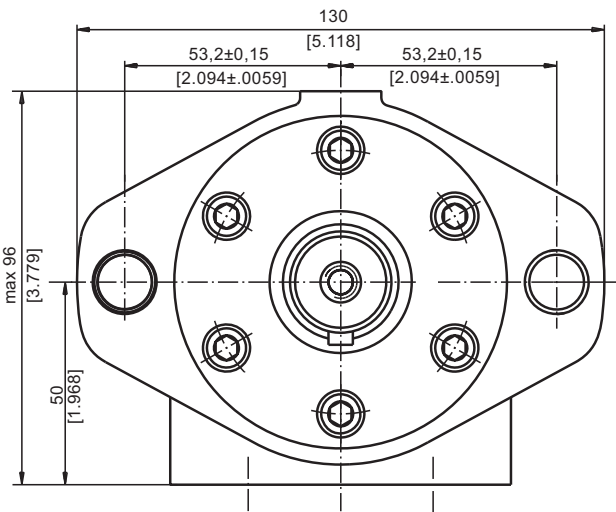
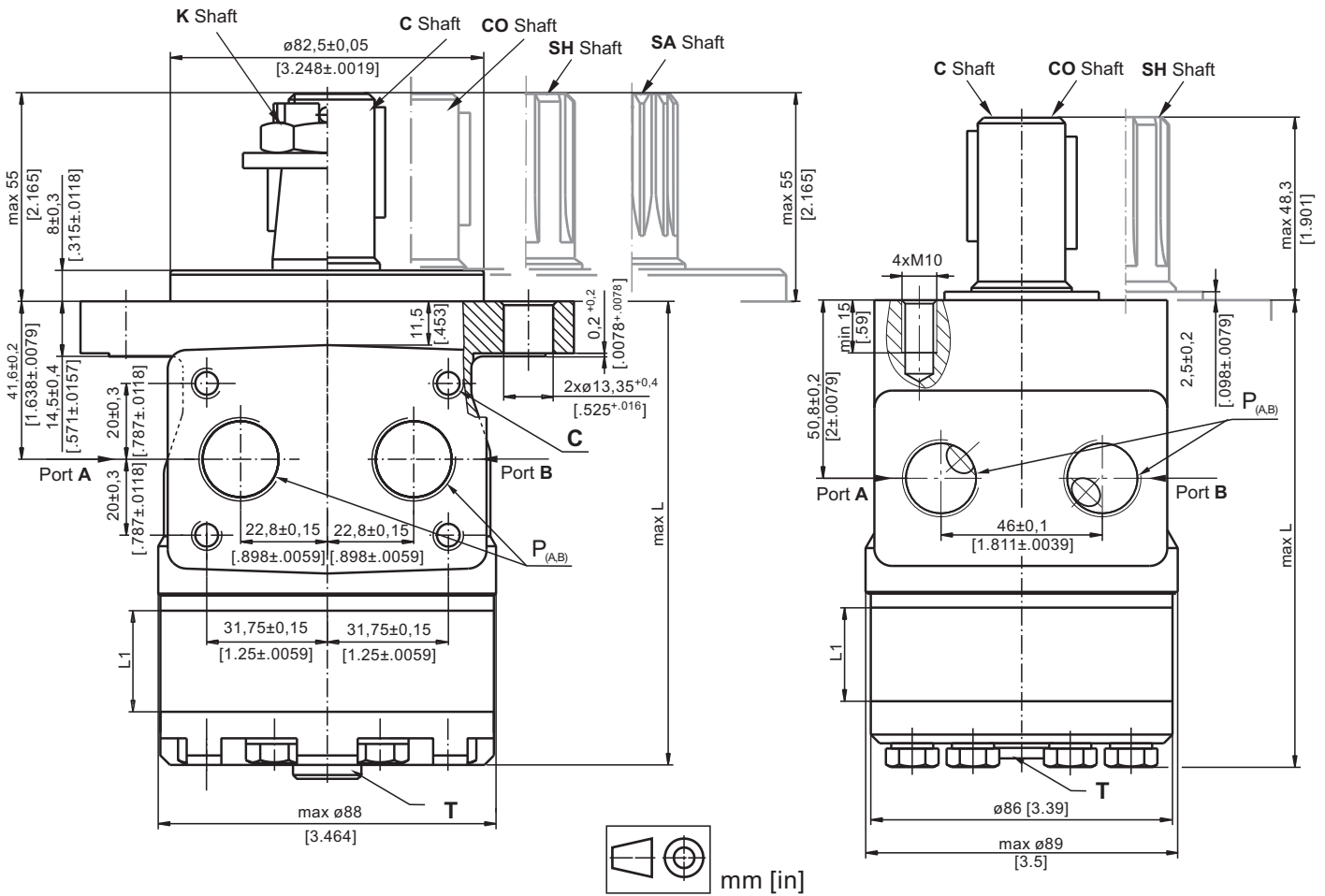

Type	L, mm [in]	Type	L, mm [in]	L <sub>1</sub> , mm [in]
PK 50	102,5 [4.04]	PKQ 50	113,5 [4.47]	6,67 [.26]
PK 80	106,5 [4.19]	PKQ 80	117,5 [4.63]	10,67 [.42]
PK 100	109,0 [4.29]	PKQ 100	120,0 [4.72]	13,33 [.52]
PK 125	112,5 [4.43]	PKQ 125	123,5 [4.86]	16,67 [.66]
PK 160	117,0 [4.61]	PKQ 160	128,0 [5.04]	21,33 [.84]
PK 200	122,5 [4.82]	PKQ 200	133,5 [5.26]	26,67 [1.05]
PK 250	129,0 [5.08]	PKQ 250	140,0 [5.51]	33,33 [1.31]
PK 315	138,5 [5.45]	PKQ 315	149,5 [5.89]	42,67 [1.68]
PK 400	149,0 [5.87]	PKQ 400	160,0 [6.30]	53,33 [2.10]

**C** : 4xM8 - 13 mm [.51 in] depth  
**P<sub>(A,B)</sub>** : 2xG1/2 or 2xM22x1,5 - 15 mm [.59 in] depth  
**T** : G1/4 or M14x1,5 - 8,5 mm [.33 in] depth (plugged)

**Standard Rotation**

Viewed from Shaft End  
 Port A Pressurized - **CW**  
 Port B Pressurized - **CCW**

**Reverse Rotation**

Viewed from Shaft End  
 Port A Pressurized - **CCW**  
 Port B Pressurized - **CW**

**SHAFT EXTENSIONS**

**C** -  $\varnothing 25$  straight, Parallel key A8x7x32 DIN 6885  
Max. Torque 34 daNm [3010 lb-in]

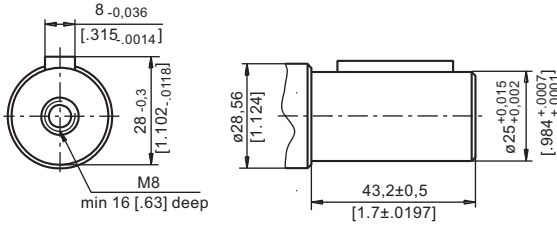

**CO** -  $\varnothing 1$ " straight, Parallel key  $\frac{1}{4}$ "x $\frac{1}{4}$ "x $\frac{1}{4}$ " BS46  
Max. Torque 34 daNm [3010 lb-in]

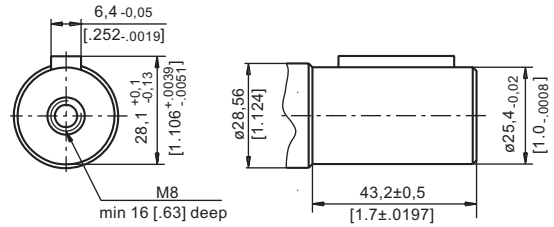

**SH** - splined, BS 2059 (SAE 6B)  
Max. Torque 40 daNm [3540 lb-in]

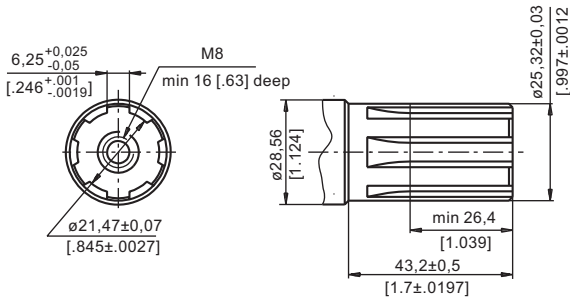

**K** - tapered 1:10, Parallel key B5x5x14 DIN 6885  
Max. Torque 40 daNm [3540 lb-in]

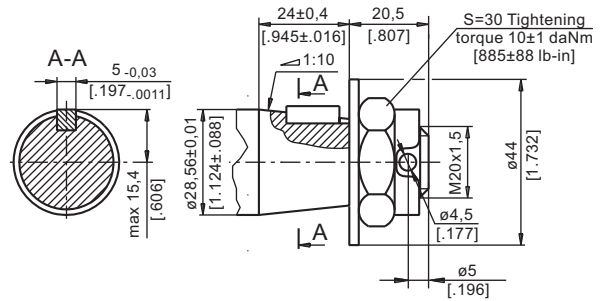

**SA** - splined, B25x22h9 DIN 5482  
Max. Torque 40 daNm [3540 lb-in]

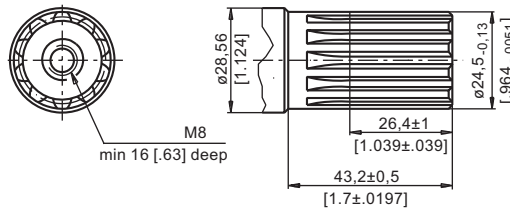

**ORDER CODE**

1	2	3	4	5	6
<b>PK</b>					

**Pos.1 - Mounting Flange**

omit - Oval mount, two holes

**Q** - Square mount, four bolts

**Pos.2 - Displacement code**

<b>50</b>	- 49,5 cm <sup>3</sup> /rev [3.02 in <sup>3</sup> /rev]
<b>80</b>	- 79,2 cm <sup>3</sup> /rev [4.83 in <sup>3</sup> /rev]
<b>100</b>	- 99,0 cm <sup>3</sup> /rev [6.04 in <sup>3</sup> /rev]
<b>125</b>	- 123,8 cm <sup>3</sup> /rev [7.55 in <sup>3</sup> /rev]
<b>160</b>	- 158,4 cm <sup>3</sup> /rev [9.66 in <sup>3</sup> /rev]
<b>200</b>	- 198,0 cm <sup>3</sup> /rev [12.10 in <sup>3</sup> /rev]
<b>250</b>	- 247,5 cm <sup>3</sup> /rev [15.10 in <sup>3</sup> /rev]
<b>315</b>	- 316,8 cm <sup>3</sup> /rev [19.30 in <sup>3</sup> /rev]
<b>400</b>	- 396,0 cm <sup>3</sup> /rev [24.16 in <sup>3</sup> /rev]

**Pos.3 - Shaft Extensions\***

- C** -  $\varnothing 25$  straight, Parallel key A8x7x32 DIN6885
- CO** -  $\varnothing 25,4$  straight, Parallel key  $\frac{1}{4}$ "x $\frac{1}{4}$ "x $\frac{1}{4}$ " BS46
- SH** -  $\varnothing 25,32$  splined BS 2059 (SAE 6B)
- K** -  $\varnothing 28,56$  tapered 1:10, Parallel key, B5x5x14 DIN6885
- SA** -  $\varnothing 24,5$  splined B25x22h9 DIN 5482

**Pos.4 - Ports**

- omit - BSPP (ISO 228)
- M** - Metric (ISO 262)

**Pos.5 - Special Features** (see page 119)

**Pos.6 - Design Series**

- omit - Factory specified

**NOTE:**

\* The permissible output torque for shafts must not be exceeded!

The hydraulic motors are mangano-phosphatized as standard.

# HYDRAULIC MOTORS RK



## APPLICATION

- » Conveyors
- » Feeding mechanism of robots and manipulators
- » Metal working machines
- » Textile machines
- » Agricultural machines
- » Food industries
- » Mining machinery etc.

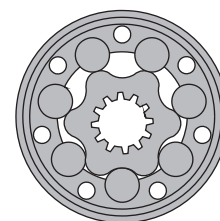
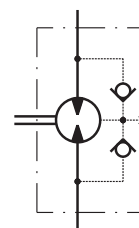

## CONTENTS

Specification data ..... 80  
 Dimensions and mounting ... 81  
 Shaft extensions ..... 82  
 Order code ..... 82

## OPTIONS

- » Model - Spool valve, gerotor
- » Antifriction conical bearing
- » Flange mount
- » Shafts - straight, splined and tapered
- » Metric and BSPP ports
- » Other special features

## GENERAL

<b>Max. Displacement,</b> cm <sup>3</sup> /rev [in <sup>3</sup> /rev]	397 [24.4]
<b>Max. Speed,</b> [RPM]	970
<b>Max. Torque,</b> daNm [lb-in]	cont.: 40 [3540] int.: 50 [4425]
<b>Max. Output,</b> kW [HP]	12,8 [17.2]
<b>Max. Pressure Drop,</b> bar [PSI]	cont.: 140 [2030] int.: 175 [2540]
<b>Max. Oil Flow,</b> lpm [GPM]	75 [18.5]
<b>Min. Speed,</b> [RPM]	10
<b>Pressure fluid</b>	Mineral based- HLP(DIN 51524) or HM(ISO 6743/4)
<b>Temperature range,</b> °C [°F]	-40÷140 [-40÷284]
<b>Optimal Viscosity range,</b> mm <sup>2</sup> /s [SUS]	20÷75 [98÷347]
<b>Filtration</b>	ISO code 20/16 (Min. recommended fluid filtration of 25 microns)

### Oil flow in drain line

Pressure drop bar [PSI]	Viscosity mm <sup>2</sup> /s [SUS]	Oil flow in drain line lpm [GPM]
100 [1450]	20 [98]	2,5 [.660]
	35 [164]	1,8 [.476]
140 [2030]	20 [98]	3,5 [.925]
	35 [164]	2,8 [.740]

### Pressure Losses

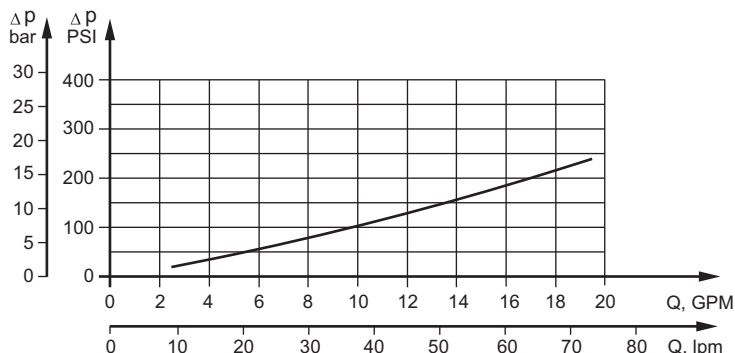

## SPECIFICATION DATA

Type	RK 50	RK 80	RK 100	RK 125	RK 160	RK 200	RK 250	RK 315	RK 400	
<b>Displacement, cm<sup>3</sup>/rev [in<sup>3</sup>/rev]</b>	51,5 [3.14]	80,3 [4.9]	99,8 [6.09]	125,5[7.67]	159,6[9.74]	199,8[12.19]	250,1[15.26]	315,7[19.26]	397 [24.4]	
<b>Max. Speed, [RPM]</b>	Cont.	775	750	600	475	375	300	240	190	150
	Int.*	970	940	750	600	470	375	300	240	185
<b>Max. Torque daNm [lb-in]</b>	Cont.	10 [850]	15,7 [1390]	19,8 [1750]	25 [2210]	32 [2830]	34 [3010]	40 [3540]	40 [3540]	40 [3540]
	Int.*	13 [1150]	19,5 [1725]	24 [2125]	30 [2655]	39 [3450]	42 [3717]	47 [4160]	50 [4425]	50 [4425]
	Peak**	17 [1505]	27 [2390]	32 [2830]	37 [3275]	46 [4070]	56 [4960]	64 [5665]	65 [5755]	65 [5755]
<b>Max. Output kW [HP]</b>	Cont.	9 [12.1]	10,4 [13.9]	10,8 [14.4]	10,8 [14.4]	10,4 [13.9]	8,8 [11.8]	8,1 [10.9]	7,4 [9.9]	6,2 [8.3]
	Int.*	10,4 [13.9]	12,6 [16.9]	12,8 [17.2]	12,5 [16.8]	11,5 [15.4]	10,2 [13.7]	9,4 [12.6]	7,8 [10.5]	7,1 [9.5]
<b>Max. Pressure Drop bar [PSI]</b>	Cont.	140 [2030]	140 [2030]	140 [2030]	140 [2030]	140 [2030]	125 [1810]	110 [1600]	90 [1300]	75 [1090]
	Int.*	175 [2540]	175 [2540]	175 [2540]	175 [2540]	175 [2540]	155 [2250]	140 [2030]	125 [1810]	90 [1305]
	Peak**	225 [3260]	225 [3260]	225 [3260]	225 [3260]	225 [3260]	225 [3260]	200 [2900]	150 [2175]	120 [1740]
<b>Max. Oil Flow lpm [GPM]</b>	Cont.	40 [10.5]	60 [15.9]	60 [15.9]	60 [15.9]	60 [15.9]	60 [15.9]	60 [15.9]	60 [15.9]	60 [15.9]
	Int.*	50 [13.2]	75 [18.5]	75 [18.5]	75 [18.5]	75 [18.5]	75 [18.5]	75 [18.5]	75 [18.5]	75 [18.5]
<b>Max. Inlet Pressure bar [PSI]</b>	Cont.	175 [2540]	175 [2540]	175 [2540]	175 [2540]	175 [2540]	175 [2540]	175 [2540]	175 [2540]	175 [2540]
	Int.*	200 [2900]	200 [2900]	200 [2900]	200 [2900]	200 [2900]	200 [2900]	200 [2900]	200 [2900]	200 [2900]
	Peak**	225 [3260]	225 [3260]	225 [3260]	225 [3260]	225 [3260]	225 [3260]	225 [3260]	225 [3260]	225 [3260]
<b>Max. Return Pressure with Drain Line or Max. Pressure in Drain Line, bar [PSI]</b>	Cont. 0-100 RPM	150 [2180]	150 [2180]	150 [2180]	150 [2180]	150 [2180]	150 [2180]	150 [2180]	150 [2180]	150 [2180]
	Cont. 100-300 RPM	75 [1090]	75 [1090]	75 [1090]	75 [1090]	75 [1090]	75 [1090]	75 [1090]	75 [1090]	75 [1090]
	Cont. 300-600 RPM	50 [725]	50 [725]	50 [725]	50 [725]	50 [725]	50 [725]	50 [725]	50 [725]	50 [725]
	Cont. >600 RPM	20 [290]	20 [290]	20 [290]	20 [290]	20 [290]	20 [290]	20 [290]	20 [290]	20 [290]
	Int.* 0-max. RPM	15 [220]	15 [220]	15 [220]	15 [220]	15 [220]	15 [220]	15 [220]	15 [220]	15 [220]
<b>Max. Starting Pressure with Unloaded Shaft, bar [PSI]</b>	10 [145]	10 [145]	10 [145]	10 [145]	10 [145]	10 [145]	10 [145]	10 [145]	10 [145]	
<b>Min. Starting Torque, daNm [lb-in]</b>	8 [710]	12 [1060]	16 [1420]	20 [1770]	25 [2215]	29 [2570]	28 [2480]	32 [2832]	35 [3100]	
<b>Min. Speed***, [RPM]</b>	10	10	10	10	10	10	10	10	10	
<b>Weight, kg [lb]</b>	6,2 [13.7]	6,3 [13.9]	6,6 [14.6]	6,7 [14.8]	6,9 [15.2]	7,4 [16.3]	7,8 [17.2]	8,5 [18.7]	9,3 [20.5]	

\* Intermittent operation: the permissible values may occur for max. 10% of every minute.

\*\* Peak load: the permissible values may occur for max. 1% of every minute.

\*\*\* For speeds lower than given, consult factory or your regional manager.

- Intermittent speed and intermittent pressure must not occur simultaneously.
- Recommended filtration is per ISO cleanliness code 20/16. A nominal filtration of 25 micron or better.
- Recommend using a premium quality, anti-wear type mineral based hydraulic oil HLP(DIN51524) or HM ( ISO 6743/4). If using synthetic fluids consult the factory for alternative seal materials.
- Recommended minimum oil viscosity 13 mm<sup>2</sup>/s [70 SUS] at 50°C [122°F].
- Recommended maximum system operating temperature is 82°C [180°F].
- To assure optimum motor life fill with fluid prior to loading and run at moderate load and speed for 10-15 minutes.

**DIMENSIONS AND MOUNTING DATA**

Oval Mount (2 Holes)

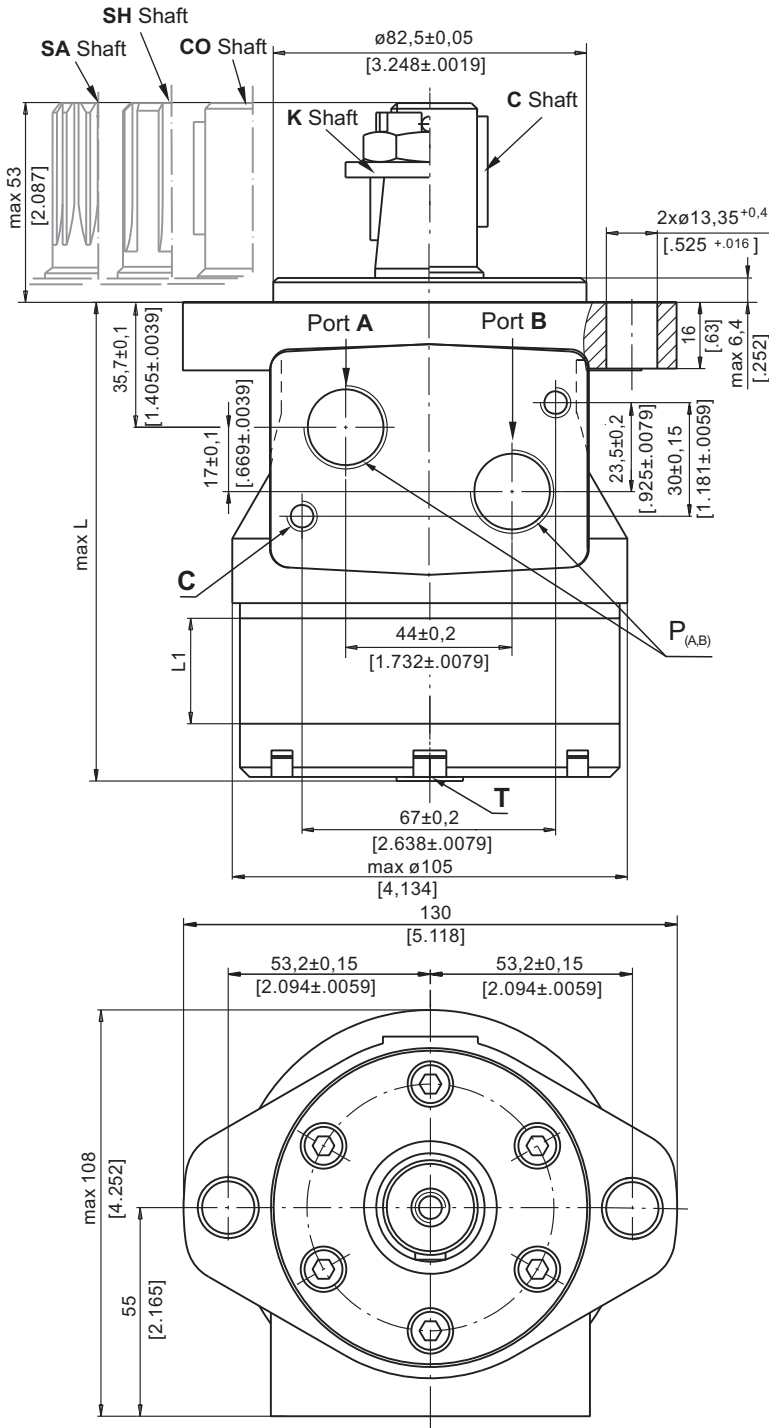

Q - Square Mount (4 Bolts)

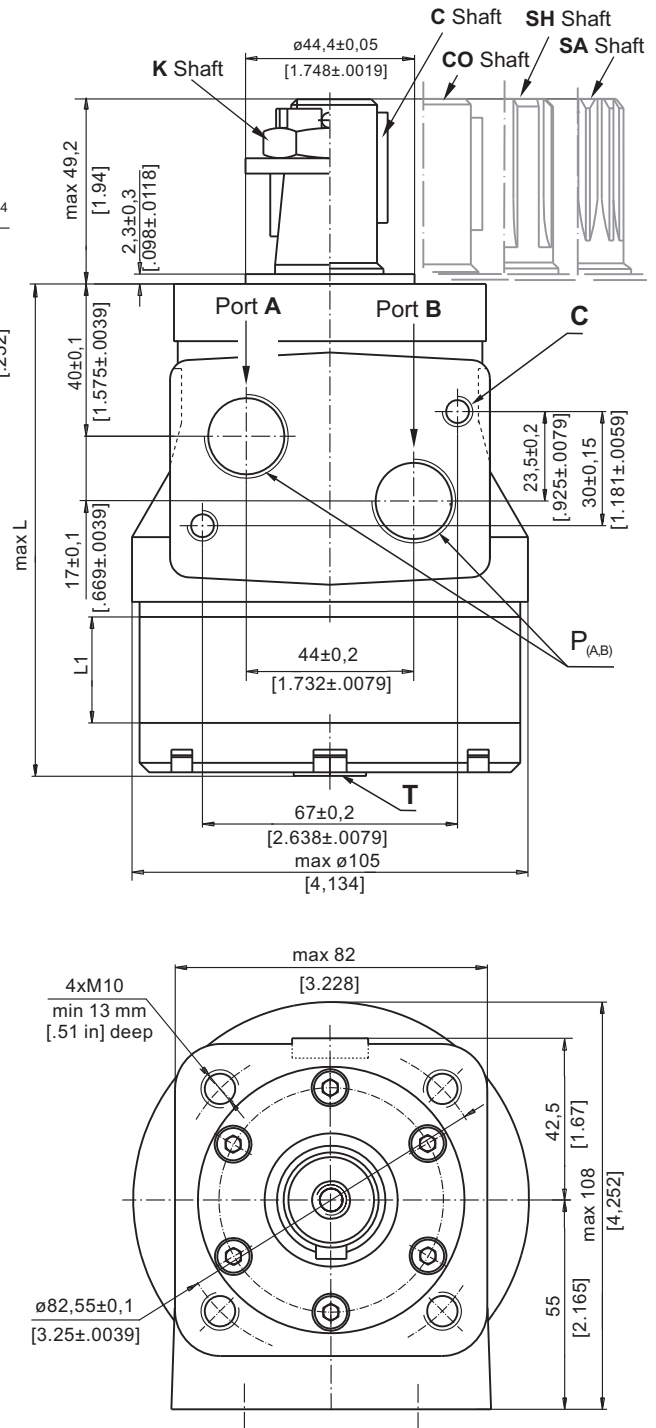

- C** : 4xM8 - 13 mm [0.51 in] depth
- P<sub>(A, B)</sub>** : 2xG1/2 or 2xM22x1,5 - 15 mm [0.59 in] depth
- T** : G1/4 or M14x1,5 - 8,5 mm [0.33 in] depth (plugged)

**Standard Rotation**  
Viewed from Shaft End  
Port **A** Pressurized - **CW**  
Port **B** Pressurized - **CCW**

**Reverse Rotation**  
Viewed from Shaft End  
Port **A** Pressurized - **CCW**  
Port **B** Pressurized - **CW**



Type	L, mm [in]	Type	L, mm [in]	L <sub>1</sub> , mm [in]
RK 50	109,5 [4.31]	RKQ 50	113,8 [4.48]	9,0 [0.35]
RK 80	114,5 [4.51]	RKQ 80	118,8 [4.68]	14,0 [0.55]
RK 100	118,0 [4.65]	RKQ 100	122,3 [4.82]	17,4 [0.69]
RK 125	122,5 [4.82]	RKQ 125	126,8 [4.99]	21,8 [0.86]
RK 160	128,5 [5.06]	RKQ 160	132,8 [5.23]	27,8 [1.09]
RK 200	135,5 [5.33]	RKQ 200	139,8 [5.50]	34,8 [1.37]
RK 250	144,0 [5.67]	RKQ 250	148,3 [5.84]	43,5 [1.71]
RK 315	155,5 [6.12]	RKQ 315	159,8 [6.29]	54,8 [2.16]
RK 400	170,0 [6.69]	RKQ 400	174,3 [6.86]	69,4 [2.73]

**SHAFT EXTENSIONS**

**C** -  $\varnothing 25$  straight, Parallel key A8x7x32 DIN 6885  
Max. Torque 34 daNm [3010 lb-in]

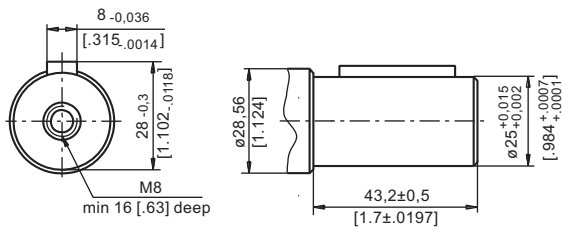

**CO** -  $\varnothing 1$ " straight, Parallel key 1/4"x1/4"x1/4" BS46  
Max. Torque 34 daNm [3010 lb-in]

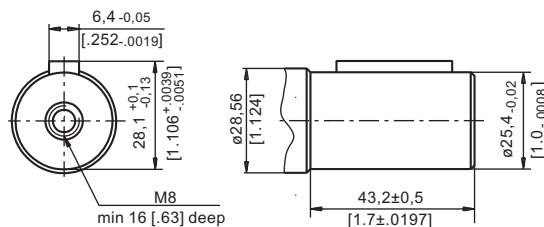

**SH** - splined, BS 2059 (SAE 6B)  
Max. Torque 40 daNm [3540 lb-in]

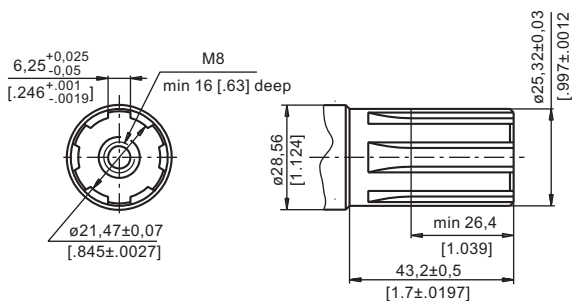

**K** - tapered 1:10, Parallel key B5x5x14 DIN 6885  
Max. Torque 40 daNm [3540 lb-in]

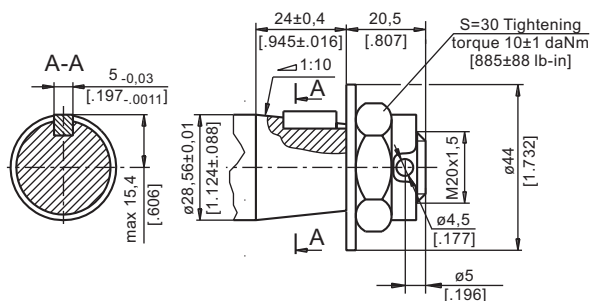

**SA** - splined, B25x22h9 DIN 5482  
Max. Torque 40 daNm [3540 lb-in]

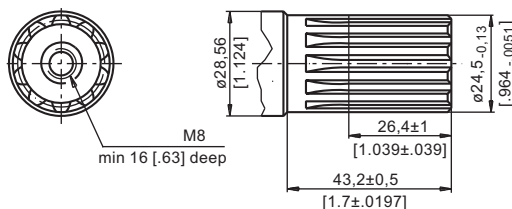

**ORDER CODE**

	1	2	3	4	5	6
<b>RK</b>						

**Pos.1 - Mounting Flange**

- omit - Oval mount, two holes
- Q** - Square mount, four bolts

**Pos.2 - Displacement code**

<b>50</b>	- 51,5 cm <sup>3</sup> /rev [3.14 in <sup>3</sup> /rev]
<b>80</b>	- 80,3 cm <sup>3</sup> /rev [4.90 in <sup>3</sup> /rev]
<b>100</b>	- 99,8 cm <sup>3</sup> /rev [6.09 in <sup>3</sup> /rev]
<b>125</b>	- 125,7 cm <sup>3</sup> /rev [7.67 in <sup>3</sup> /rev]
<b>160</b>	- 159,6 cm <sup>3</sup> /rev [9.74 in <sup>3</sup> /rev]
<b>200</b>	- 199,8 cm <sup>3</sup> /rev [12.19 in <sup>3</sup> /rev]
<b>250</b>	- 250,1 cm <sup>3</sup> /rev [15.26 in <sup>3</sup> /rev]
<b>315</b>	- 315,7 cm <sup>3</sup> /rev [19.26 in <sup>3</sup> /rev]
<b>400</b>	- 397,0 cm <sup>3</sup> /rev [24.40 in <sup>3</sup> /rev]

**Pos.3 - Shaft Extensions\***

- C** -  $\varnothing 25$  straight, Parallel key A8x7x32 DIN6885
- CO** -  $\varnothing 25,4$  straight, Parallel key 1/4"x1/4"x1/4" BS46
- SH** -  $\varnothing 25,32$  splined BS 2059 (SAE 6B)
- K** -  $\varnothing 28,56$  tapered 1:10, Parallel key, B5x5x14 DIN6885
- SA** -  $\varnothing 24,5$  splined B25x22h9 DIN 5482

**Pos.4 - Ports**

- omit - BSPP (ISO 228)
- M** - Metric (ISO 262)

**Pos.5 - Special Features** (see page 119)

**Pos.6 - Design Series**

- omit - Factory specified

**NOTE:**

\* The permissible output torque for shafts must not be exceeded!

The hydraulic motors are manganophosphatized as standard.

# HYDRAULIC MOTORS RW



## APPLICATION

- » Conveyors
- » Feeding mechanism of robots and manipulators
- » Metal working machines
- » Textile machines
- » Agricultural machines
- » Food industries
- » Grass cutting machinery etc.

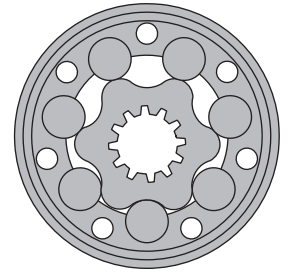

## CONTENTS

Specification data .....	84
Function diagrams .....	85+89
Dimensions and mounting .....	90
Permissible shaft Seal Pressure ...	91
Permissible shaft loads .....	91
Shaft extensions .....	92
Order code .....	92

## OPTIONS

- » Model - Spool valve, roll-gerotor
- » Wheel mount
- » Shafts - straight and tapered
- » Shaft seal for high and low pressure
- » Metric and BSPP ports
- » Other special features

## GENERAL

<b>Max. Displacement,</b> cm <sup>3</sup> /rev [in <sup>3</sup> /rev]	397 [24.4]
<b>Max. Speed,</b> [RPM]	1029
<b>Max. Torque,</b> daNm [lb-in]	cont.: 61 [5400] int.: 69 [6100]
<b>Max. Output,</b> kW [HP]	15 [20.1]
<b>Max. Pressure Drop,</b> bar [PSI]	cont.: 175 [2540] int.: 200 [2900]
<b>Max. Oil Flow,</b> lpm [GPM]	90 [23.8]
<b>Min. Speed,</b> [RPM]	10
<b>Pressure fluid</b>	Mineral based- HLP(DIN 51524) or HM(ISO 6743/4)
<b>Temperature range,</b> °C [°F]	-40÷140 [-40÷284]
<b>Optimal Viscosity range,</b> mm <sup>2</sup> /s [SUS]	20÷75 [98÷347]
<b>Filtration</b>	ISO code 20/16 (Min. recommended fluid filtration of 25 microns)

### Oil flow in drain line

Pressure drop bar [PSI]	Viscosity mm <sup>2</sup> /s [SUS]	Oil flow in drain line lpm [GPM]
100 [1450]	20 [98]	2,5 [.660]
	35 [164]	1,8 [.476]
140 [2030]	20 [98]	3,5 [.925]
	35 [164]	2,8 [.740]

### Pressure Losses

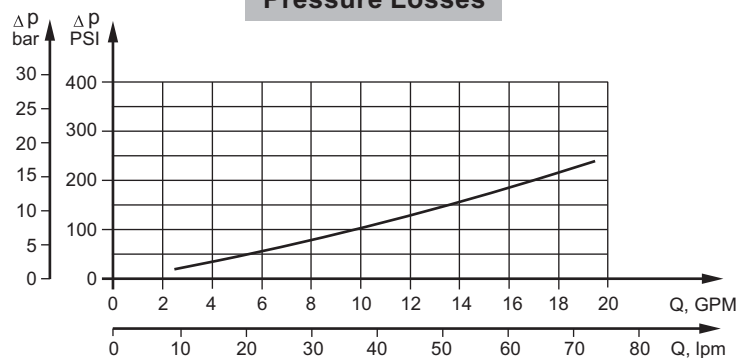

## SPECIFICATION DATA

Type	RW 50	RW 80	RW 100	RW 125	RW 160	RW 200	RW 250	RW 315	RW 400	
<b>Displacement, cm<sup>3</sup>/rev</b> [in <sup>3</sup> /rev]	51,5 [3.14]	80,3 [4.90]	99,8 [6.09]	125,7 [7.67]	159,6 [9.74]	199,8 [12.19]	250,1 [15.26]	315,7 [19.26]	397 [24.4]	
<b>Max. Speed, [RPM]</b>	Cont.	775	750	600	475	375	300	300	240	190
	Int.*	1029	940	750	600	470	375	360	285	226
<b>Max. Torque daNm [lb-in]</b>	Cont.	10 [900]	20 [1770]	24 [2125]	30 [2655]	39 [3450]	45 [4000]	54 [4780]	55 [4870]	61 [5400]
	Int.*	13 [1150]	22 [1947]	28 [2480]	34 [3010]	43 [3805]	50 [4425]	61 [5400]	69 [6100]	69 [6100]
	Peak**	17 [1505]	27 [2390]	32 [2832]	37 [3275]	46 [4070]	56 [4960]	71 [6280]	84 [7430]	87 [7700]
<b>Max. Output kW [HP]</b>	Cont.	7 [9.5]	12,5 [17]	13 [17.4]	12,5 [16.8]	11,5 [15.4]	11 [14.8]	10 [13.4]	9 [12]	7,8 [10.5]
	Int.*	8,5 [11.9]	15 [20.1]	15 [20.1]	14,5 [19.5]	14 [18.8]	13 [17.4]	12 [16.1]	10 [13.4]	10,6 [14.2]
<b>Max. Pressure Drop bar [PSI]</b>	Cont.	140 [2030]	175 [2540]	175 [2540]	175 [2540]	175 [2540]	175 [2540]	175 [2540]	135 [1960]	110 [1600]
	Int.*	175 [2540]	200 [2900]	200 [2900]	200 [2900]	200 [2900]	200 [2900]	200 [2900]	175 [2540]	140 [2030]
	Peak**	225 [3260]	225 [3260]	225 [3260]	225 [3260]	225 [3260]	225 [3260]	225 [3260]	210 [3045]	175 [2540]
<b>Max. Oil Flow lpm [GPM]</b>	Cont.	40 [10,6]	60 [15,9]	60 [15,9]	60 [15,9]	60 [15,9]	60 [15,9]	75 [19,8]	75 [19,8]	75 [19,8]
	Int.*	50 [13,2]	75 [19,8]	75 [19,8]	75 [19,8]	75 [19,8]	75 [19,8]	90 [23,8]	90 [23,8]	90 [23,8]
<b>Max. Inlet Pressure bar [PSI]</b>	Cont.	175 [2540]	175 [2540]	175 [2540]	175 [2540]	175 [2540]	175 [2540]	175 [2540]	175 [2540]	175 [2540]
	Int.*	200 [2900]	200 [2900]	200 [2900]	200 [2900]	200 [2900]	200 [2900]	200 [2900]	200 [2900]	200 [2900]
	Peak**	225 [3260]	225 [3260]	225 [3260]	225 [3260]	225 [3260]	225 [3260]	225 [3260]	225 [3260]	225 [3260]
<b>Max. Return Pressure with Drain Line bar [PSI]</b>	Cont.	175 [2540]	175 [2540]	175 [2540]	175 [2540]	175 [2540]	175 [2540]	175 [2540]	175 [2540]	175 [2540]
	Int.*	200 [2900]	200 [2900]	200 [2900]	200 [2900]	200 [2900]	200 [2900]	200 [2900]	200 [2900]	200 [2900]
	Peak**	225 [3260]	225 [3260]	225 [3260]	225 [3260]	225 [3260]	225 [3260]	225 [3260]	225 [3260]	225 [3260]
<b>Max. Starting Pressure with Unloaded Shaft, bar [PSI]</b>	10 [145]	10 [145]	10 [145]	9 [130]	7 [102]	5 [73]	5 [73]	5 [73]	5 [73]	
<b>Min. Starting Torque daNm [lb-in]</b>	At max.press.									
	drop Cont.	8 [710]	15 [1330]	20 [1770]	25 [2215]	32 [2832]	41 [3630]	50 [4425]	50 [4425]	50 [4425]
	At max.press. drop Int.*	10 [885]	17 [1505]	23 [2035]	28 [2480]	37 [3275]	46 [4070]	55 [4870]	66 [5840]	61 [5400]
<b>Min. Speed***, [RPM]</b>	10	10	10	10	10	10	10	10	10	
<b>Weight, kg [lb]</b>	9,6 [21.2]	9,7 [21.4]	9,8 [21.7]	10,0 [22.1]	10,3 [22.7]	10,8 [23.8]	11,3 [24.9]	11,8 [26]	12,5 [27.63]	

\* Intermittent operation: the permissible values may occur for max. 10% of every minute.

\*\* Peak load: the permissible values may occur for max. 1% of every minute.

\*\*\* For speeds lower than given, consult factory or your regional manager.

- Intermittent speed and intermittent pressure must not occur simultaneously.
- Recommended filtration is per ISO cleanliness code 20/16. A nominal filtration of 25 micron or better.
- Recommend using a premium quality, anti-wear type mineral based hydraulic oil HLP(DIN51524) or HM ( ISO 6743/4).  
If using synthetic fluids consult the factory for alternative seal materials.
- Recommended minimum oil viscosity 13 mm<sup>2</sup>/s [70 SUS] at 50°C [122°F].
- Recommended maximum system operating temperature is 82°C [180°F].
- To assure optimum motor life fill with fluid prior to loading and run at moderate load and speed for 10-15 minutes.

**FUNCTION DIAGRAMS**

**RW 50**

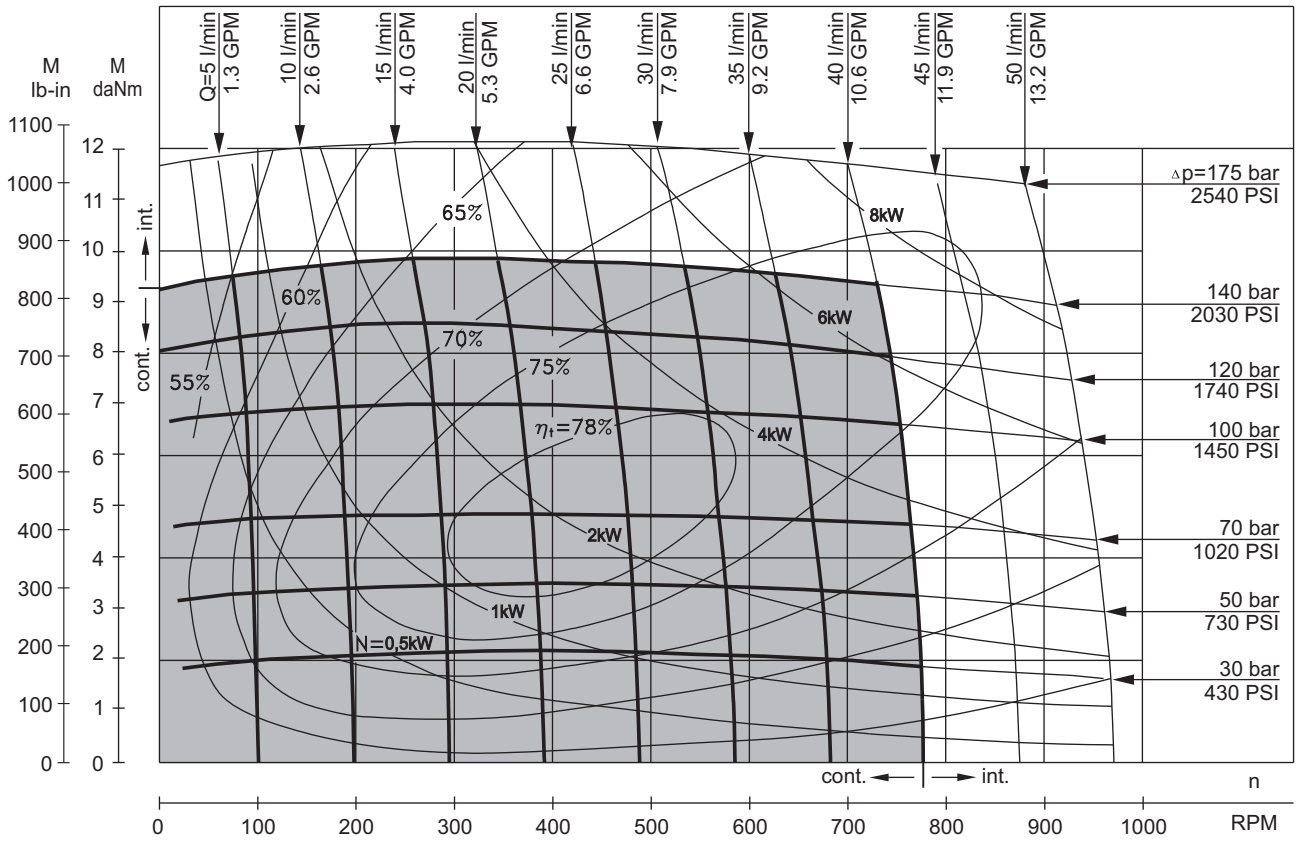

**RW 80**

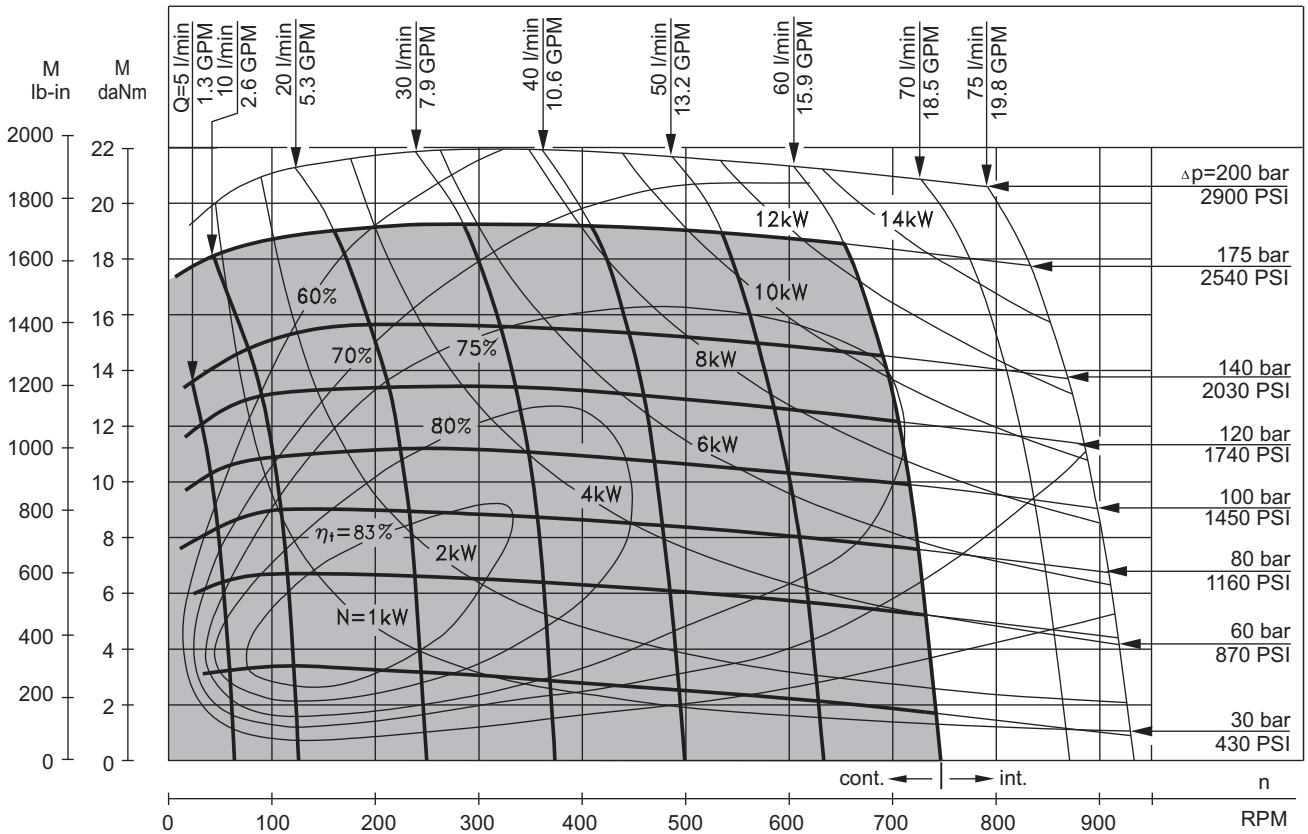

The function diagrams data is for average performance of randomly selected motors at back pressure 5÷10 bar [72.5÷145 PSI] and oil with viscosity of 32 mm<sup>2</sup>/s [150 SUS] at 50°C [122°F].

**FUNCTION DIAGRAMS**

**RW 100**

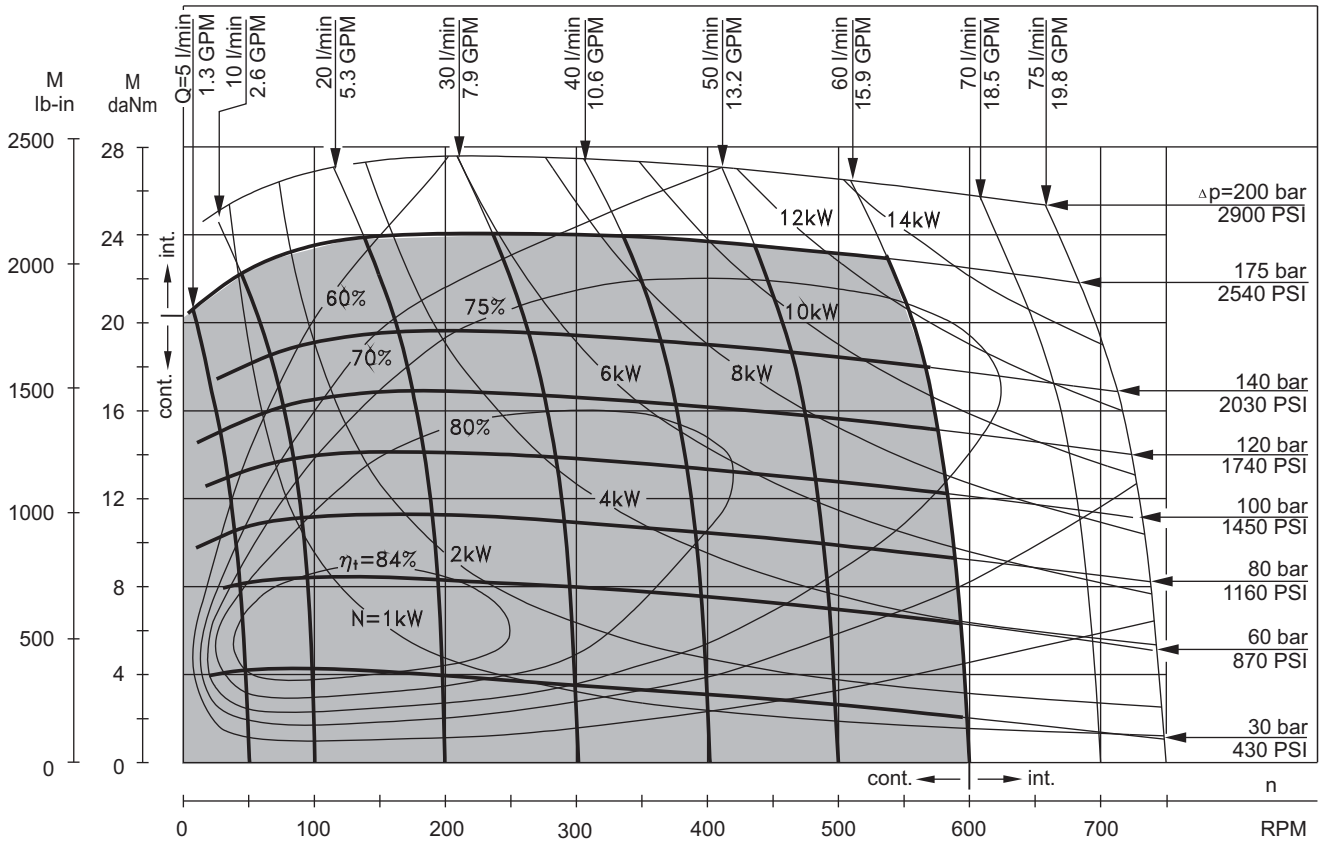

**RW 125**

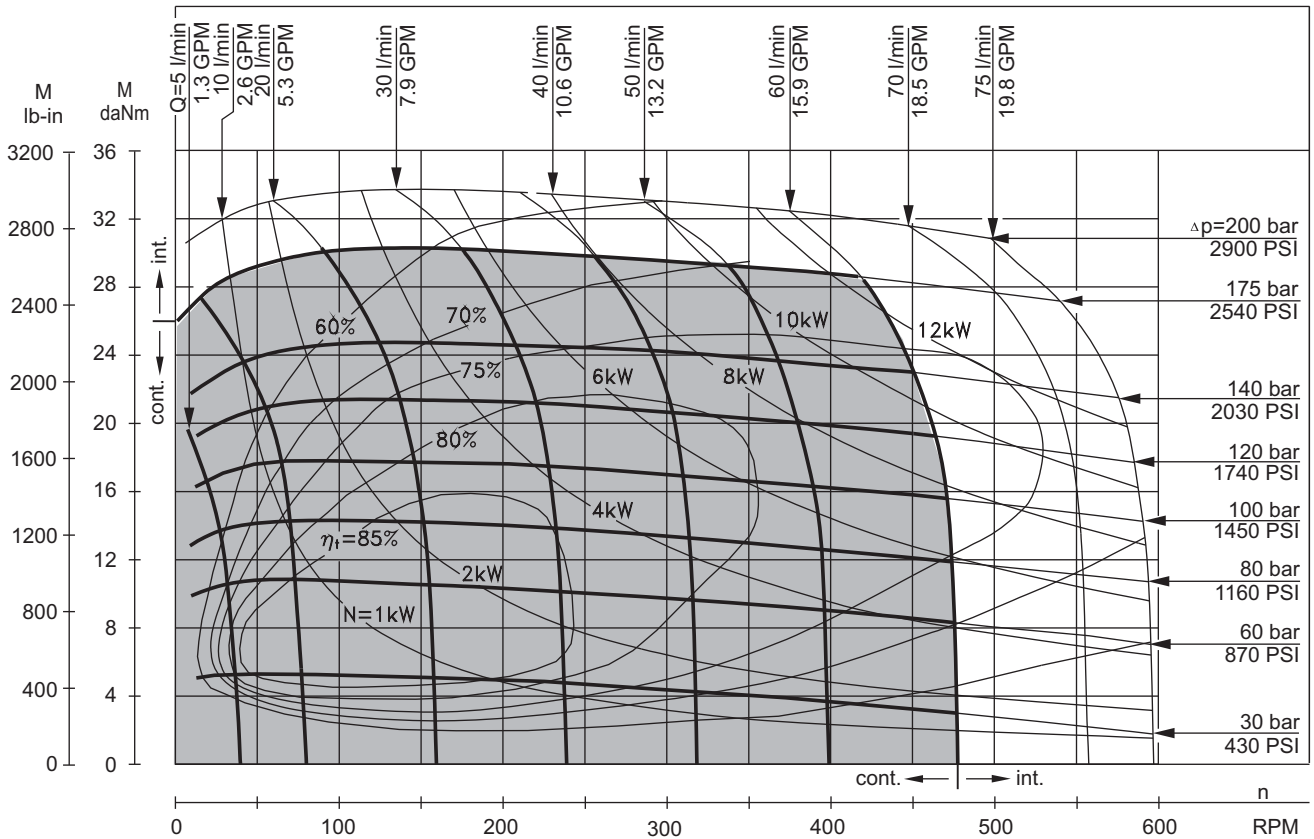

The function diagrams data is for average performance of randomly selected motors at back pressure  $5 \div 10 \text{ bar}$  [72.5 ÷ 145 PSI] and oil with viscosity of  $32 \text{ mm}^2/\text{s}$  [150 SUS] at  $50^\circ\text{C}$  [122°F].

**FUNCTION DIAGRAMS**

**RW 160**

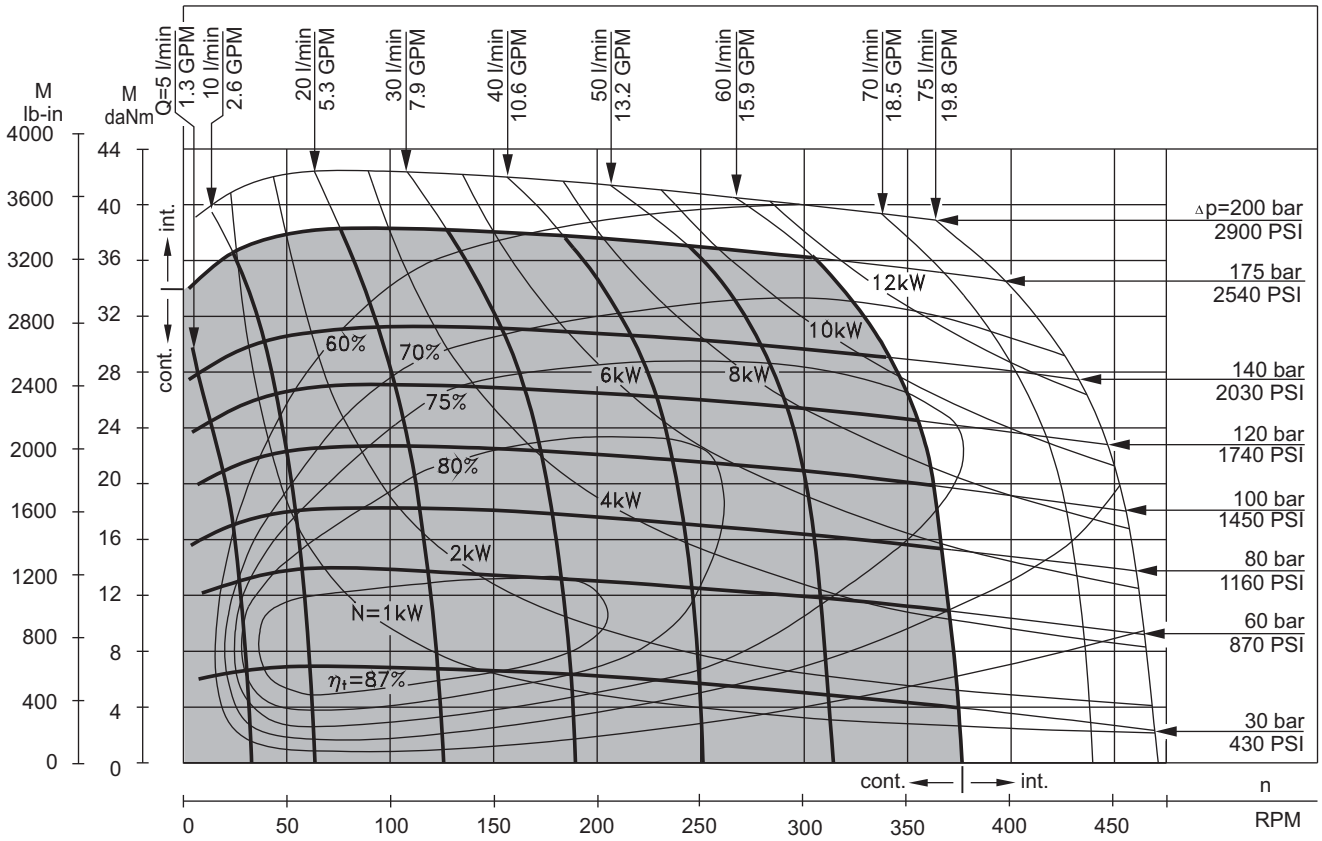

**RW 200**

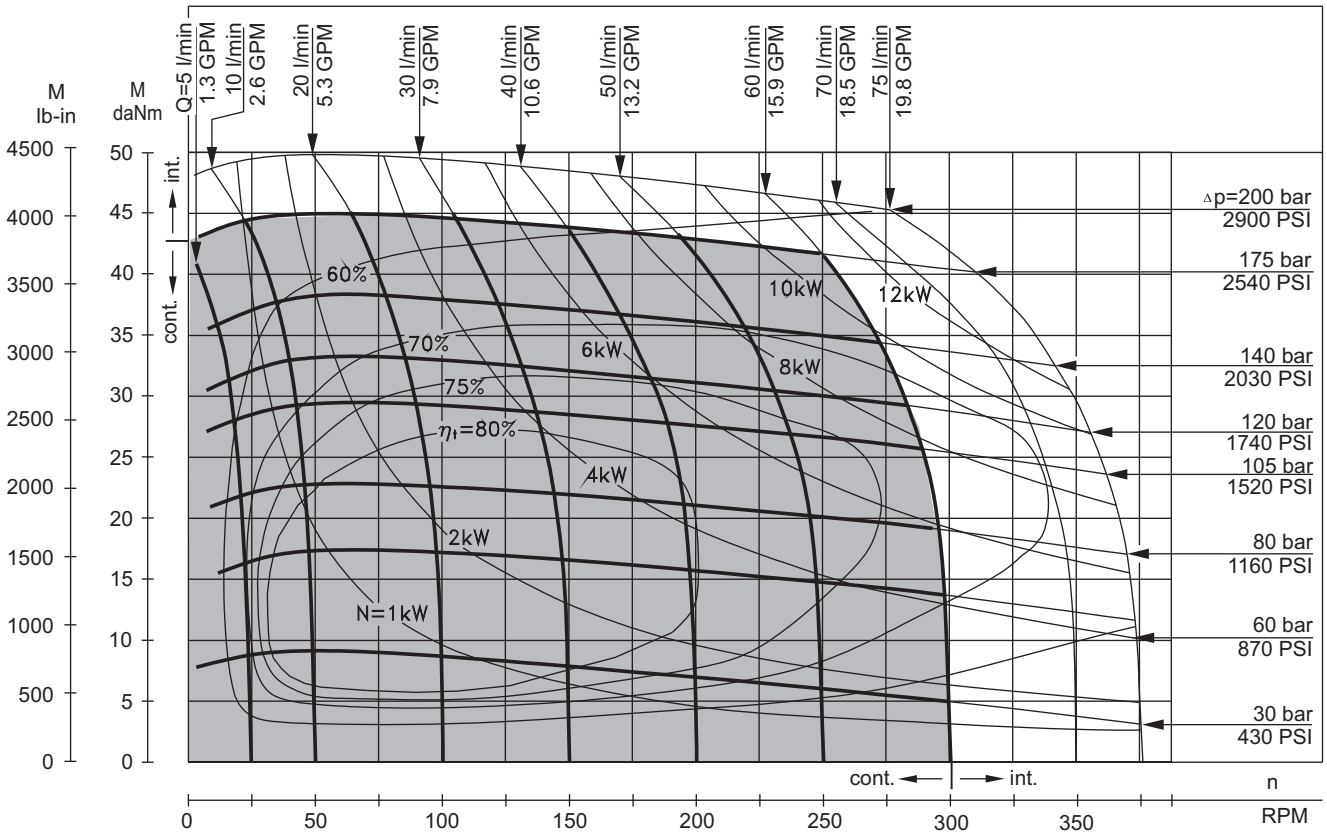

The function diagrams data is for average performance of randomly selected motors at back pressure  $5 \div 10$  bar [72.5 ÷ 145 PSI] and oil with viscosity of 32 mm<sup>2</sup>/s [150 SUS] at 50°C [122°F].

**FUNCTION DIAGRAMS**

**RW 250**

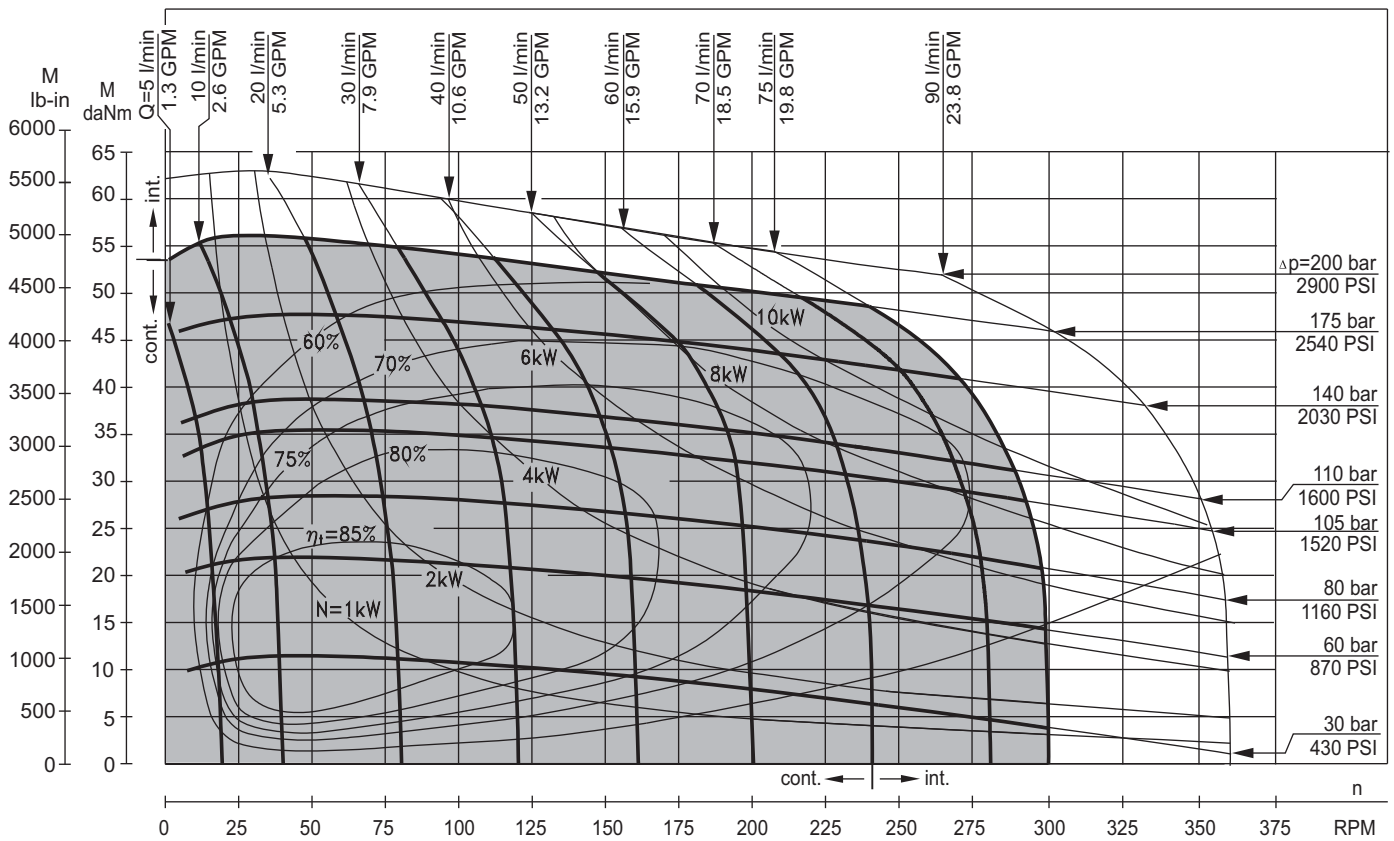

**RW 315**

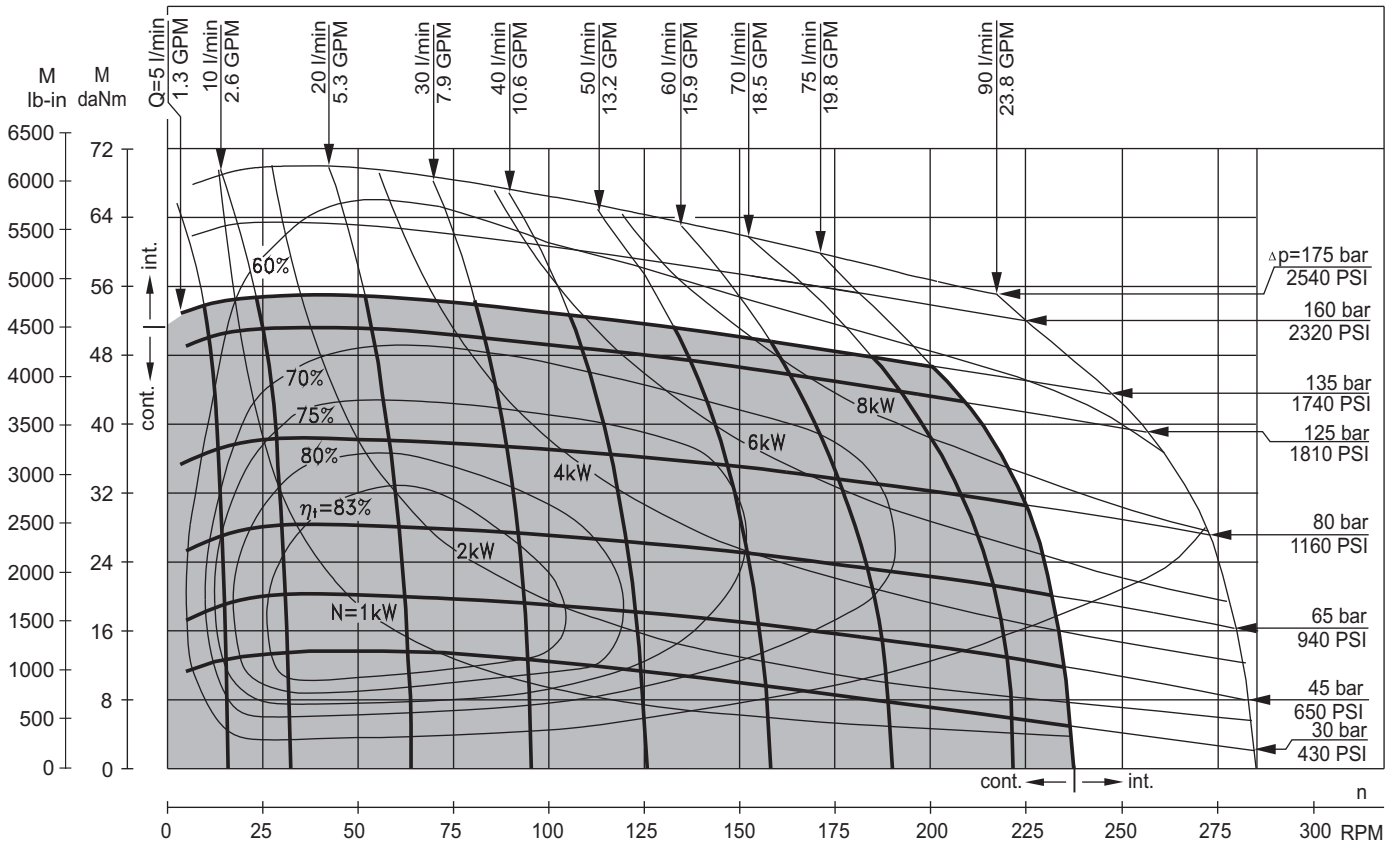

The function diagrams data is for average performance of randomly selected motors at back pressure 5÷10 bar [72.5÷145 PSI] and oil with viscosity of 32 mm<sup>2</sup>/s [150 SUS] at 50°C [122°F].

**FUNCTION DIAGRAMS**

**RW 400**

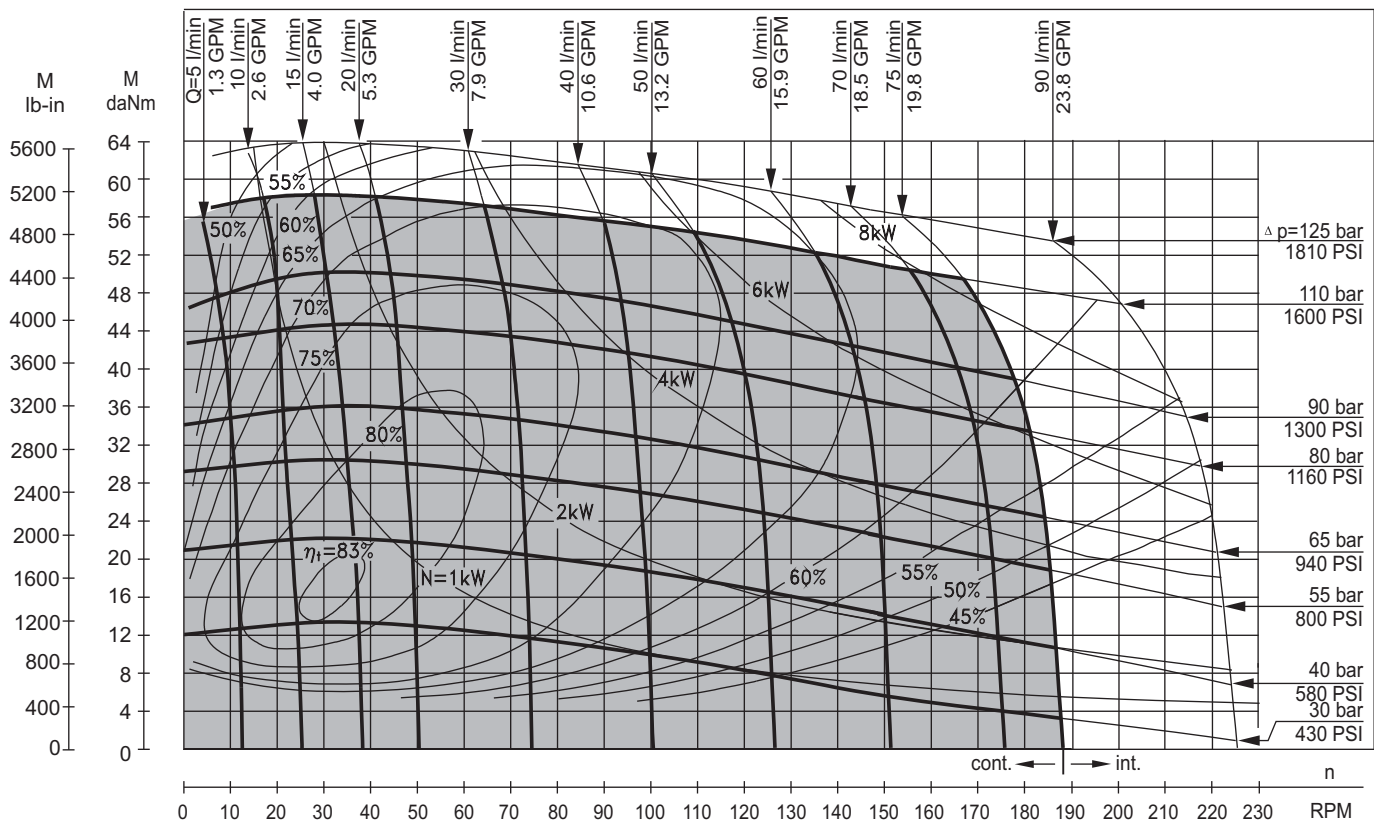

The function diagrams data is for average performance of randomly selected motors at back pressure  $5 \div 10 \text{ bar}$  [72.5  $\div$  145 PSI] and oil with viscosity of  $32 \text{ mm}^2/\text{s}$  [150 SUS] at  $50^\circ\text{C}$  [122°F].

**DIMENSIONS AND MOUNTING DATA**

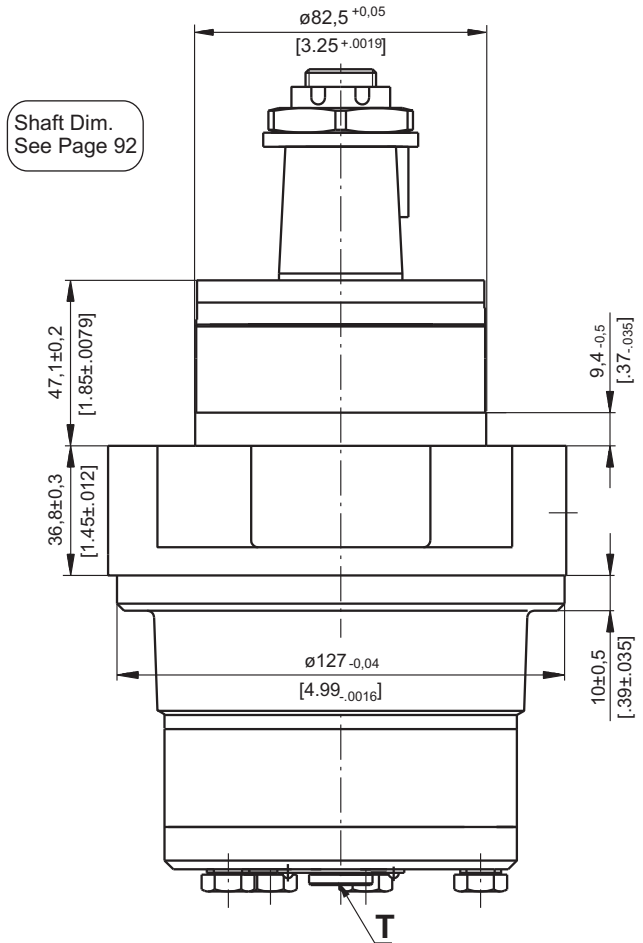
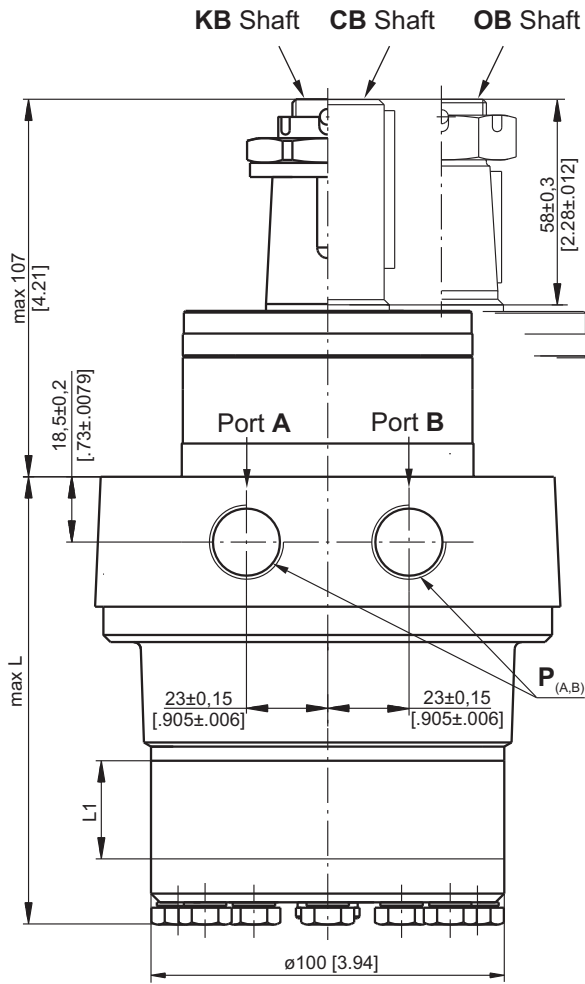

Type	L, mm [in]	L1, mm [in]
RW 50	108,0 [4.25]	9,0 [.35]
RW 80	113,0 [4.45]	14,0 [.55]
RW 100	116,5 [4.59]	17,4 [.69]
RW 125	120,5 [4.74]	21,8 [.86]
RW 160	126,5 [4.98]	27,8 [1.09]
RW 200	133,5 [5.26]	34,8 [1.37]
RW 250	142,5 [5.61]	43,5 [1.71]
RW 315	153,5 [6.04]	54,8 [2.16]
RW 400	168,5 [6.63]	69,4 [2.73]

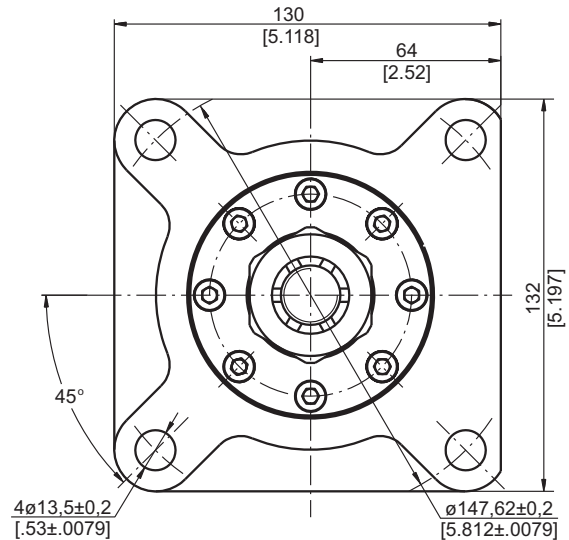

P<sub>(A,B)</sub>: 2xG1/2 or 2xM22x1,5 - 17 mm [.67 in.] depth  
T : G1/4 or M14x1,5 - 12 mm [.47 in.] depth (plugged)

**Standard Rotation**  
Viewed from Shaft End  
Port A Pressurized - CW  
Port B Pressurized - CCW

**Reverse Rotation**  
Viewed from Shaft End  
Port A Pressurized - CCW  
Port B Pressurized - CW



**MAX. PERMISSIBLE SHAFT SEAL PRESSURE**

**RW...; RW...UK motors with drain connection:**

The shaft seal pressure equals the pressure in the drain line.

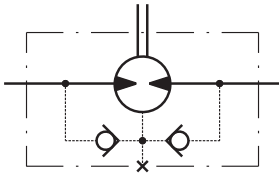

**RW...1 motors without drain connection:**

The shaft seal pressure never exceeds the pressure in the return line.

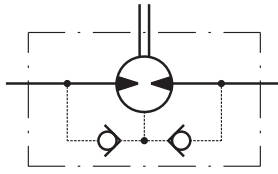

**RW...U motors with high pressure seal and drain connection:**

The shaft seal pressure equals the pressure in the drain line.

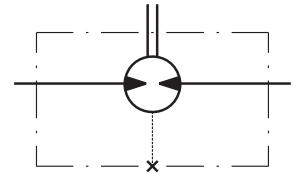

**Max. return pressure without drain line or max. pressure in the drain line**

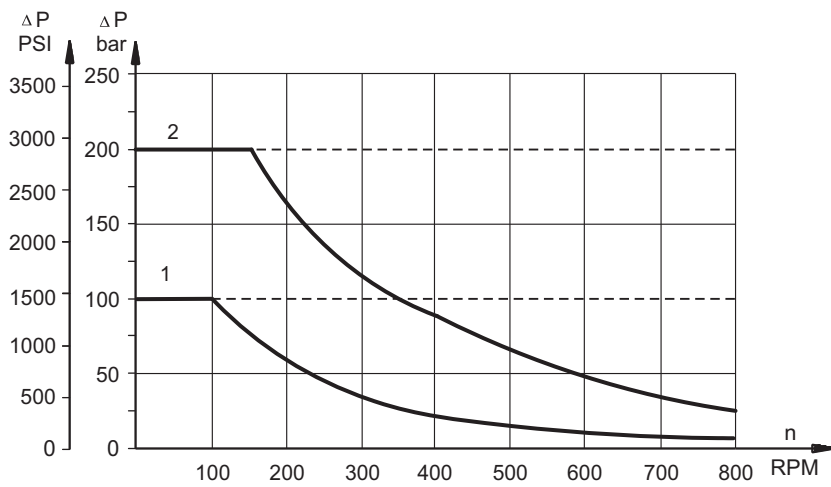

- 1: Drawing for Standard Shaft Seal
- 2: Drawing for High Pressure Seal ("U" Seal)

— - continuous operations  
- - - - intermittent operations

**PERMISSIBLE SHAFT LOADS**

The curve applies to a B10 bearing life of 2000 hours.

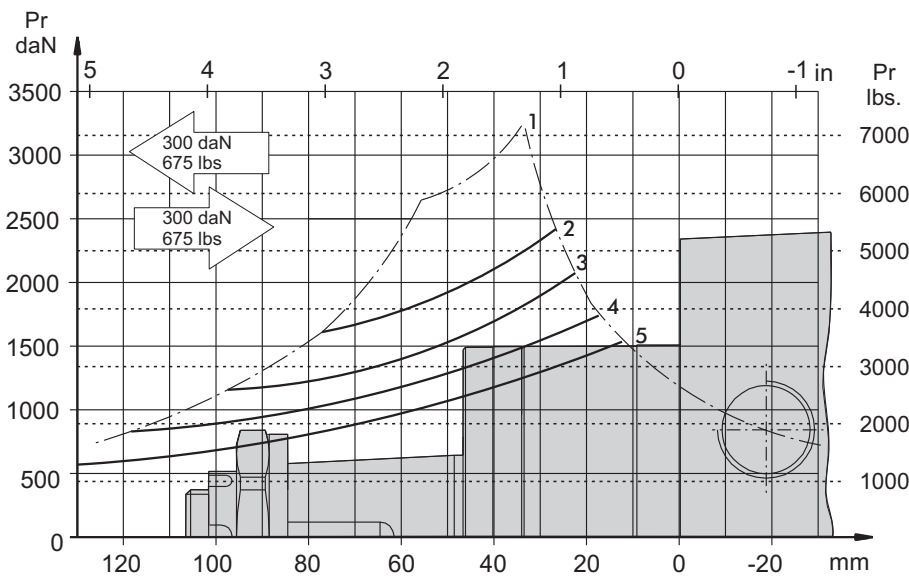

- 1. Permissible radial shaft load
- 2. Drawing by n= 50 rpm
- 3. Drawing by n=100 rpm
- 4. Drawing by n=200 rpm
- 5. Drawing by n=400 rpm

**SHAFT EXTENSIONS**

**CB** -  $\varnothing 32$  straight, Parallel key A10x8x45 DIN 6885  
Max. Torque 77 daNm [6815 lb-in]

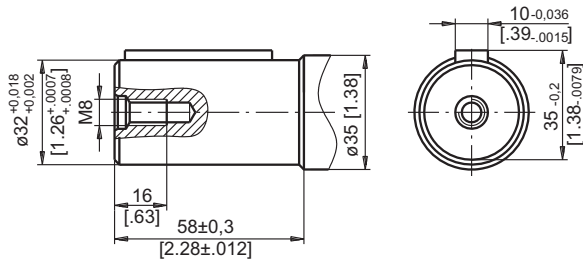

**KB** - tapered 1:10, Parallel key B6x6x20 DIN 6885  
Max. Torque 95 daNm [8400 lb-in]

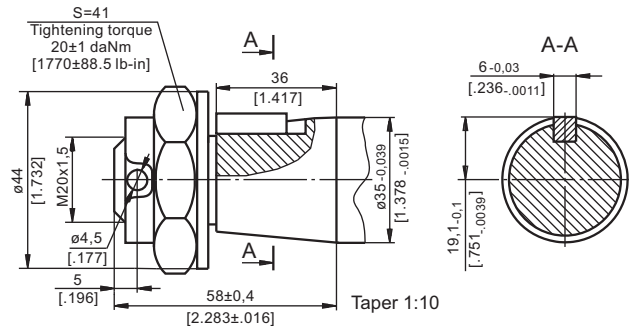

**OB** - tapered 1:8 SAEJ 501, Parallel key  $5/16$ "x $5/16$ "x $1 1/4$ " BS46  
Max. Torque 77 daNm [6815 lb-in]

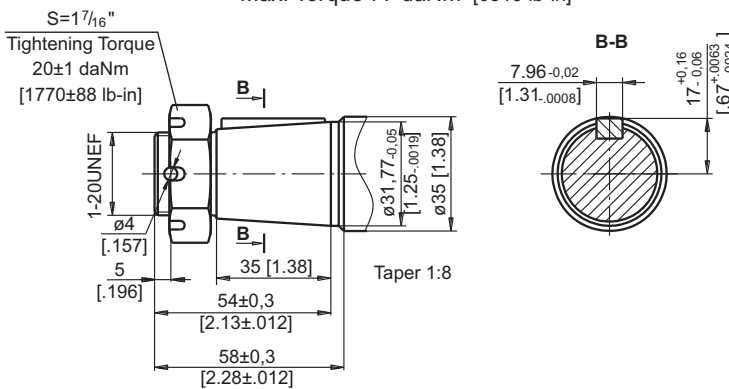

**ORDER CODE**

RW	1	2	3	4	5	6	7
----	---	---	---	---	---	---	---

<b>Pos.1 - Displacement code</b>	
<b>50</b>	- 51,5 cm <sup>3</sup> /rev [ 3.14 in <sup>3</sup> /rev]
<b>80</b>	- 80,3 cm <sup>3</sup> /rev [ 4.90 in <sup>3</sup> /rev]
<b>100</b>	- 99,8 cm <sup>3</sup> /rev [ 6.09 in <sup>3</sup> /rev]
<b>125</b>	- 125,7 cm <sup>3</sup> /rev [ 7.67 in <sup>3</sup> /rev]
<b>160</b>	- 159,6 cm <sup>3</sup> /rev [ 9.74 in <sup>3</sup> /rev]
<b>200</b>	- 199,8 cm <sup>3</sup> /rev [12.19 in <sup>3</sup> /rev]
<b>250</b>	- 250,1 cm <sup>3</sup> /rev [15.26 in <sup>3</sup> /rev]
<b>315</b>	- 315,7 cm <sup>3</sup> /rev [19.26 in <sup>3</sup> /rev]
<b>400</b>	- 397,0 cm <sup>3</sup> /rev [24.40 in <sup>3</sup> /rev]
<b>Pos.2 - Shaft Extensions*</b>	
<b>CB</b>	- $\varnothing 32$ straight, Parallel key A10x8x45 DIN6885
<b>KB</b>	- $\varnothing 35$ tapered 1:10, Parallel key B6x6x20 DIN6888
<b>OB</b>	- $\varnothing 1 1/4$ " tapered 1:8, Parallel key $5/16$ "x $5/16$ "x $1 1/4$ " BS46

<b>Pos.3 - Shaft Seal Pressure</b>	
omit	- Standard shaft seal
<b>U</b>	- High pressure shaft seal without check valves
<b>UK</b>	- High pressure shaft seal with check valve
<b>Pos.4 - Drain Port</b>	
omit	- with drain port
<b>1</b>	- without drain port
<b>Pos.5 - Ports</b>	
omit	- BSPP (ISO 228)
<b>M</b>	- Metric (ISO 262)
<b>Pos.6 - Special Features</b>	(see page 119)
<b>Pos.7 - Design Series</b>	
omit	- Factory specified

**NOTE:**

\* The permissible output torque for shafts must not be exceeded!

The hydraulic motors are manganese-phosphatized as standard.

# HYDRAULIC MOTORS MH



## APPLICATION

- » Conveyors
- » Feeding mechanism of robots and manipulators
- » Metal working machines
- » Textile machines
- » Agricultural machines
- » Food industries
- » Mining machinery etc.

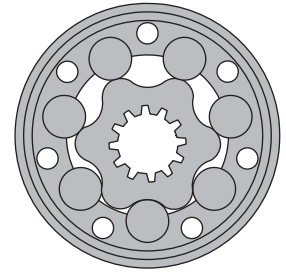

## CONTENTS

Specification data .....	94
Function diagrams .....	95÷97
Permissible shaft loads .....	97
Dimensions and mounting .....	98
Permissible shaft seal pressure.....	99
Tacho connection.....	100
Shaft extensions .....	100
Order code .....	101

## OPTIONS

- » Model - Spool valve, roll-gerotor
- » Flange mount
- » Shafts - straight, splined and tapered
- » Metric and BSPP ports
- » Other special features

## GENERAL

<b>Max. Displacement,</b> cm <sup>3</sup> /rev [in <sup>3</sup> /rev]	502,4 [30.7]
<b>Max. Speed,</b> [RPM]	445
<b>Max. Torque,</b> daNm [lb-in]	cont.: 84 [7434] int.: 104 [9204]
<b>Max. Output,</b> kW [HP]	18,5 [24.8]
<b>Max. Pressure Drop,</b> bar [PSI]	cont.: 175 [2540] int.: 200 [2900]
<b>Max. Oil Flow,</b> lpm [GPM]	90 [23.78]
<b>Min. Speed,</b> [RPM]	5
<b>Pressure fluid</b>	Mineral based- HLP(DIN 51524) or HM(ISO 6743/4)
<b>Temperature range,</b> °C [°F]	-40÷140 [-40÷284]
<b>Optimal Viscosity range,</b> mm <sup>2</sup> /s [SUS]	20÷75 [98÷347]
<b>Filtration</b>	ISO code 20/16 (Min. recommended fluid filtration of 25 microns)

### Oil flow in drain line

Pressure drop bar [PSI]	Viscosity mm <sup>2</sup> /s [SUS]	Oil flow in drain line lpm [GPM]
100 [1450]	20 [98]	2,5 [.660]
	35 [164]	1,8 [.476]
140 [2030]	20 [98]	3,5 [.925]
	35 [164]	2,8 [.740]

### Pressure Losses

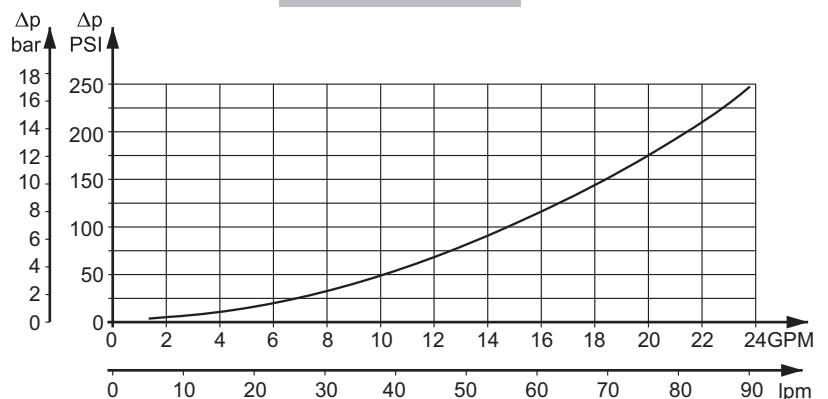

## SPECIFICATION DATA

Type		MH 200	MH 250	MH 315	MH 400	MH 500
<b>Displacement, cm<sup>3</sup>/rev [in<sup>3</sup>/rev]</b>		201,3 [12.3]	252 [15.4]	314,9 [19.2]	396,8 [24.2]	502,4 [30.7]
<b>Max. Speed, [RPM]</b>	Cont.	370	295	235	185	150
	Int.*	445	350	285	225	180
<b>Max. Torque daNm [lb-in]</b>	Cont.	51 [4510]	61 [5398]	74 [6548]	84 [7434]	82 [7257]
	Int.*	58 [5130]	70 [6195]	82 [7257]	98 [8673]	104 [9204]
	Peak**	64 [5064]	79 [6992]	98 [8673]	109 [9647]	117 [10350]
<b>Max. Output kW [HP]</b>	Cont.	16 [21]	16 [21]	14 [18.7]	12,5 [16.7]	11 [14.7]
	Int.*	18,5 [24.8]	18,5 [24.8]	15,5 [20.7]	15 [20.1]	14 [18.7]
<b>Max. Pressure Drop bar [PSI]</b>	Cont.	175 [2540]	175 [2540]	175 [2540]	155 [2240]	125 [1810]
	Int.*	200 [2900]	200 [2900]	200 [2900]	190 [2750]	160 [2320]
	Peak**	225 [3260]	225 [3260]	225 [3260]	210 [3045]	180 [2610]
<b>Max. Oil Flow lpm [GPM]</b>	Cont.	75 [19.81]	75 [19.81]	75 [19.81]	75 [19.81]	75 [19.81]
	Int.*	90 [23.78]	90 [23.78]	90 [23.78]	90 [23.78]	90 [23.78]
<b>Max. Inlet Pressure bar [PSI]</b>	Cont.	200 [2900]	200 [2900]	200 [2900]	200 [2900]	200 [2900]
	Int.*	225 [3260]	225 [3260]	225 [3260]	225 [3260]	225 [3260]
	Peak**	250 [3626]	250 [3626]	250 [3626]	250 [3626]	250 [3626]
<b>Max. Starting Pressure with Unloaded Shaft, bar [PSI]</b>		5 [72]	5 [72]	5 [72]	5 [72]	5 [72]
<b>Min. Starting Torque, daNm [lb-in]</b>	At max.press.dropCont	39 [3450]	52 [4600]	66 [5840]	72 [6370]	72 [6370]
	At max.press.drop Int.*	45 [3980]	59 [5221]	73 [6460]	88 [7788]	88 [7788]
<b>Min. Speed***, [RPM]</b>		10	10	8	5	5
<b>Weight, kg [lb]</b>		10,5 [23.2]	11 [24.3]	11,5 [25.4]	12,3 [27.1]	13 [28.7]

\* Intermittent operation: the permissible values may occur for max. 10% of every minute.

\*\* Peak load: the permissible values may occur for max. 1% of every minute.

\*\*\* For speeds lower than given, consult factory or your regional manager.

- Intermittent speed and intermittent pressure must not occur simultaneously.
- Recommended filtration is per ISO cleanliness code 20/16. A nominal filtration of 25 micron or better.
- Recommend using a premium quality, anti-wear type mineral based hydraulic oil HLP(DIN51524) or HM ( ISO 6743/4).  
If using synthetic fluids consult the factory for alternative seal materials.
- Recommended minimum oil viscosity 13 mm<sup>2</sup>/s [70 SUS] at 50°C [122°F].
- Recommended maximum system operating temperature is 82°C [180°F].
- To assure optimum motor life fill with fluid prior to loading and run at moderate load and speed for 10-15 minutes.

**FUNCTION DIAGRAMS**

**MH 200**

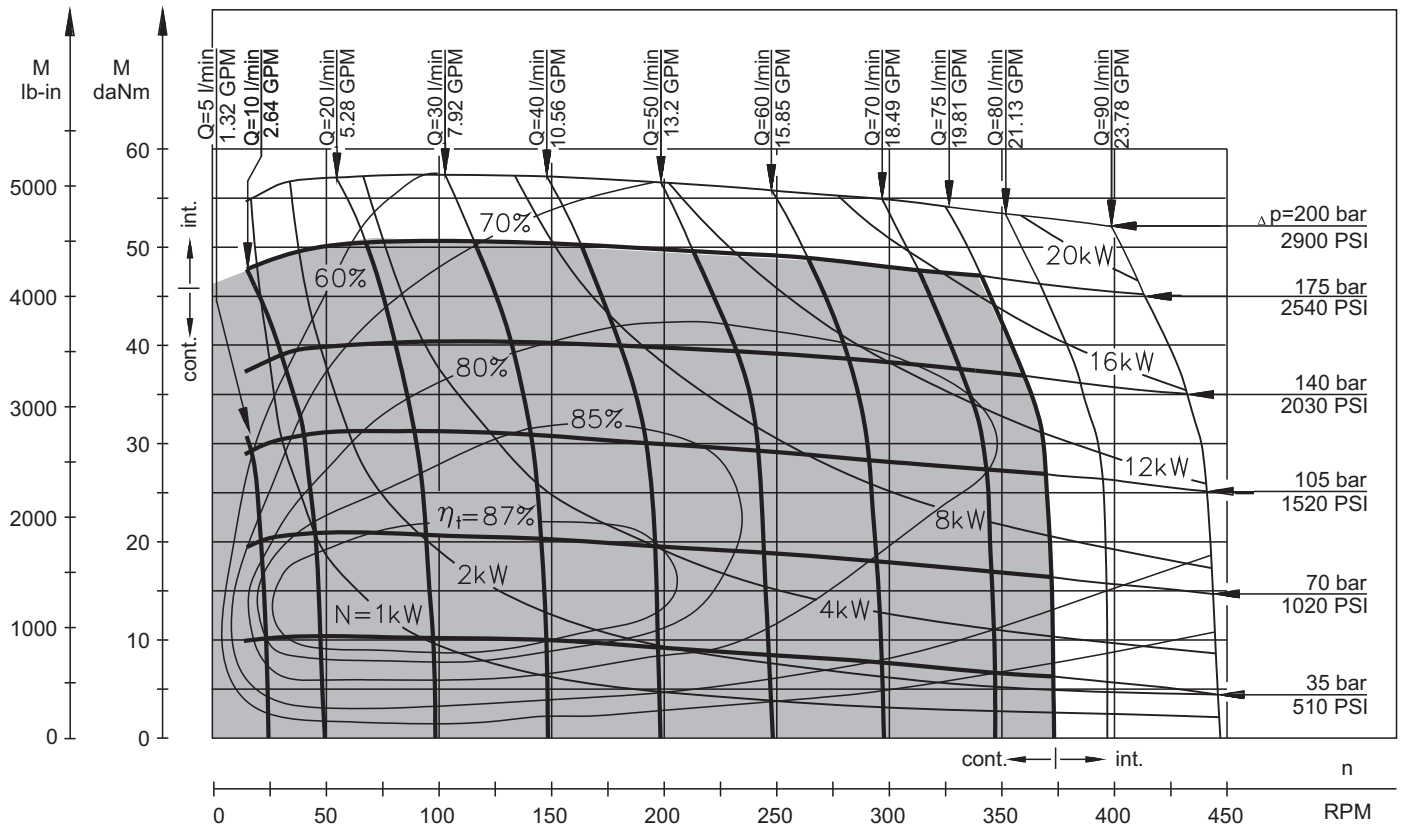

**MH 250**

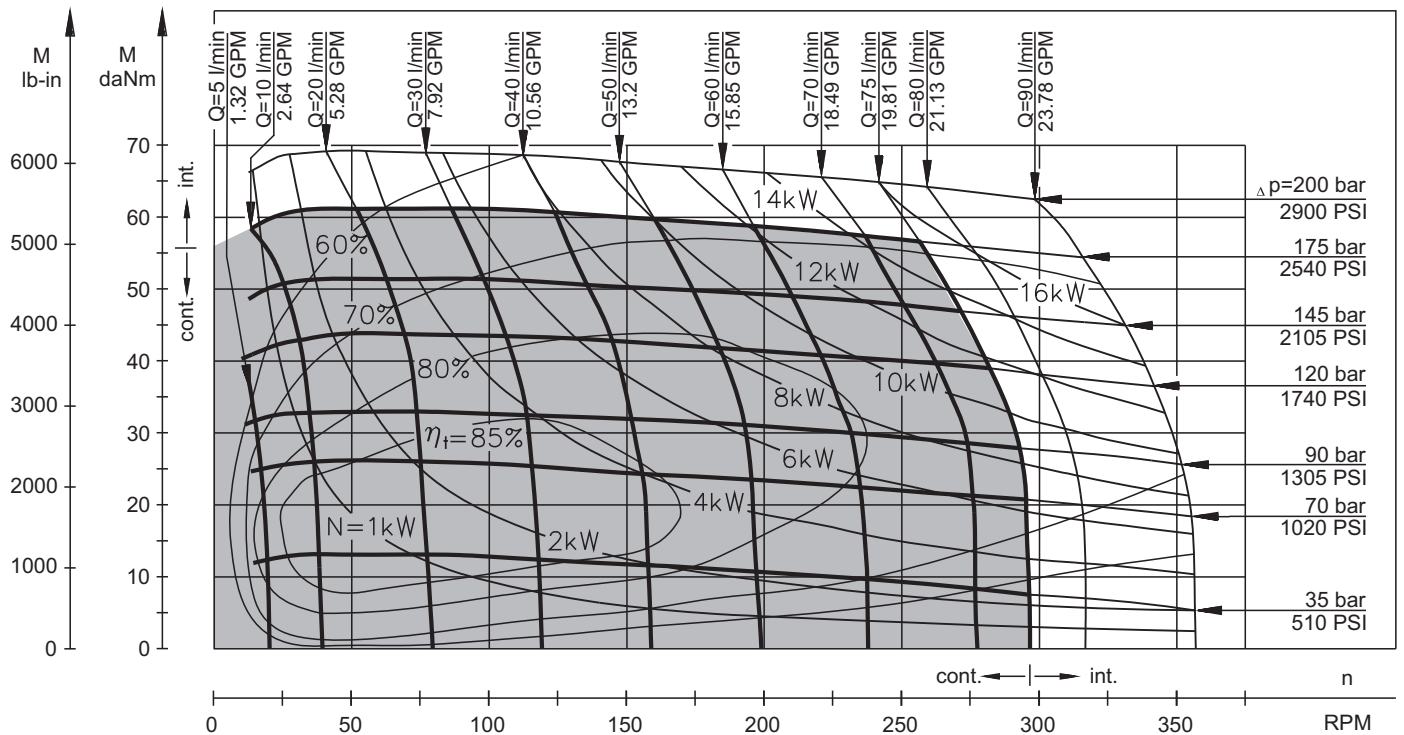

The function diagrams data is for average performance of randomly selected motors at back pressure  $5 \pm 10$  bar [72.5  $\pm$  145 PSI] and oil with viscosity of 32 mm<sup>2</sup>/s [150 SUS] at 50°C [122°F].

**FUNCTION DIAGRAMS**

**MH 315**

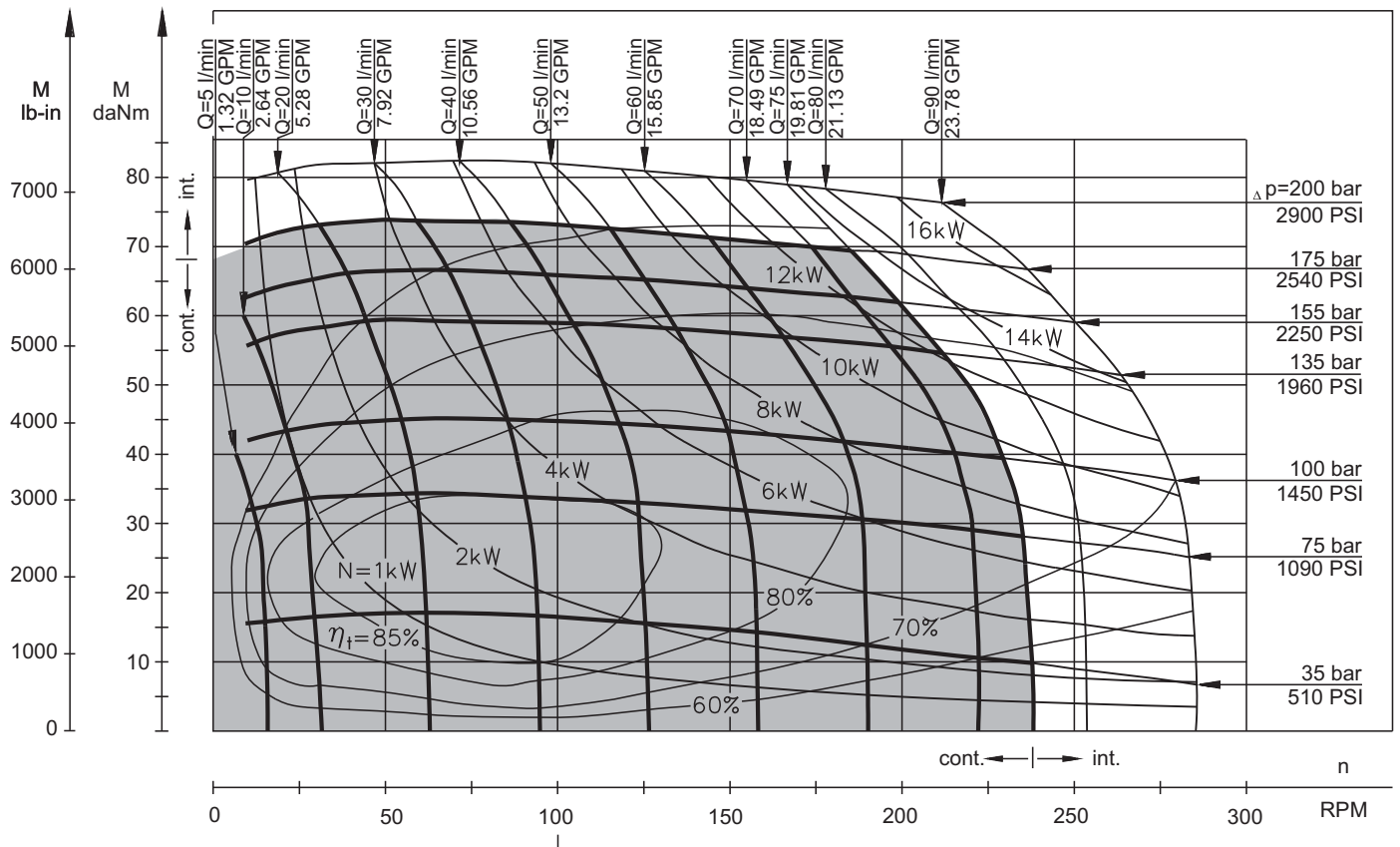

**MH 400**

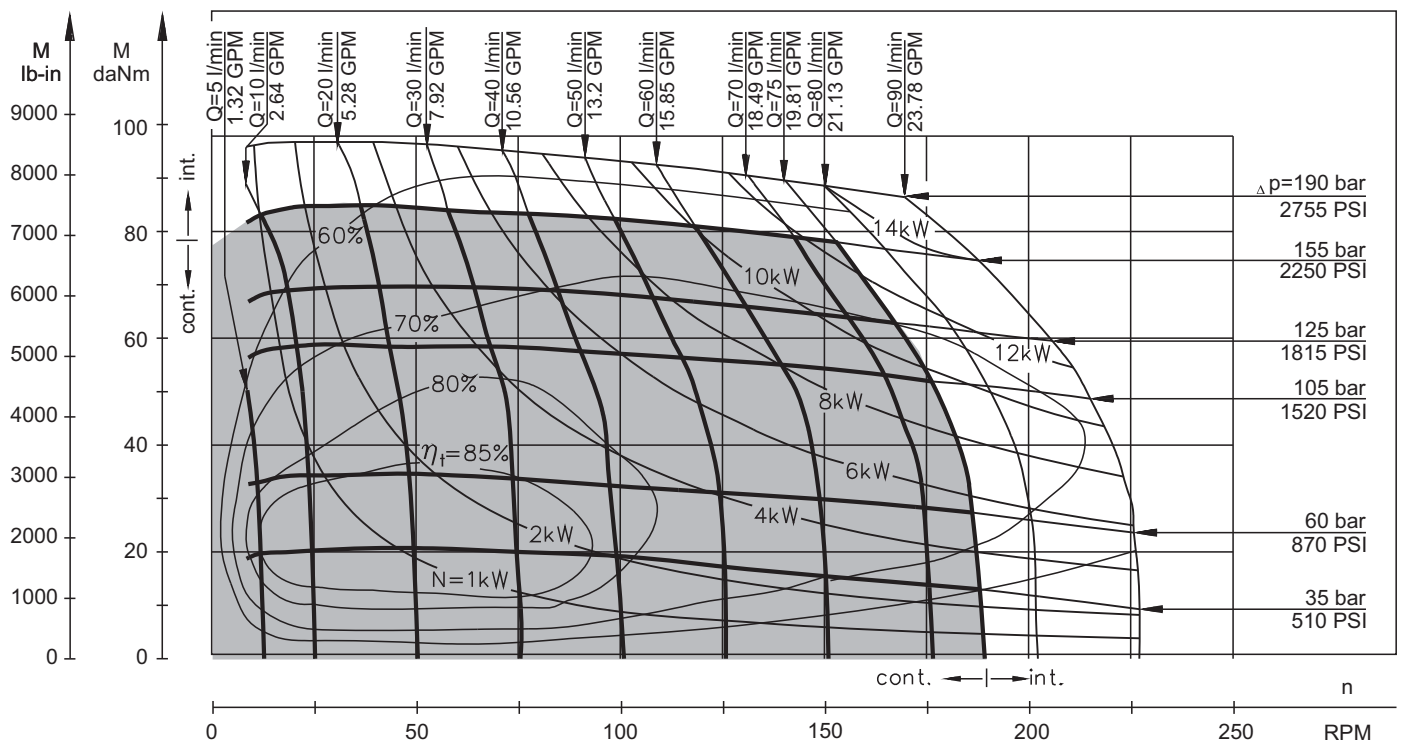

The function diagrams data is for average performance of randomly selected motors at back pressure  $5 \pm 10$  bar [72.5  $\pm$  145 PSI] and oil with viscosity of 32 mm<sup>2</sup>/s [150 SUS] at 50°C [122°F].

**FUNCTION DIAGRAMS**

**MH 500**

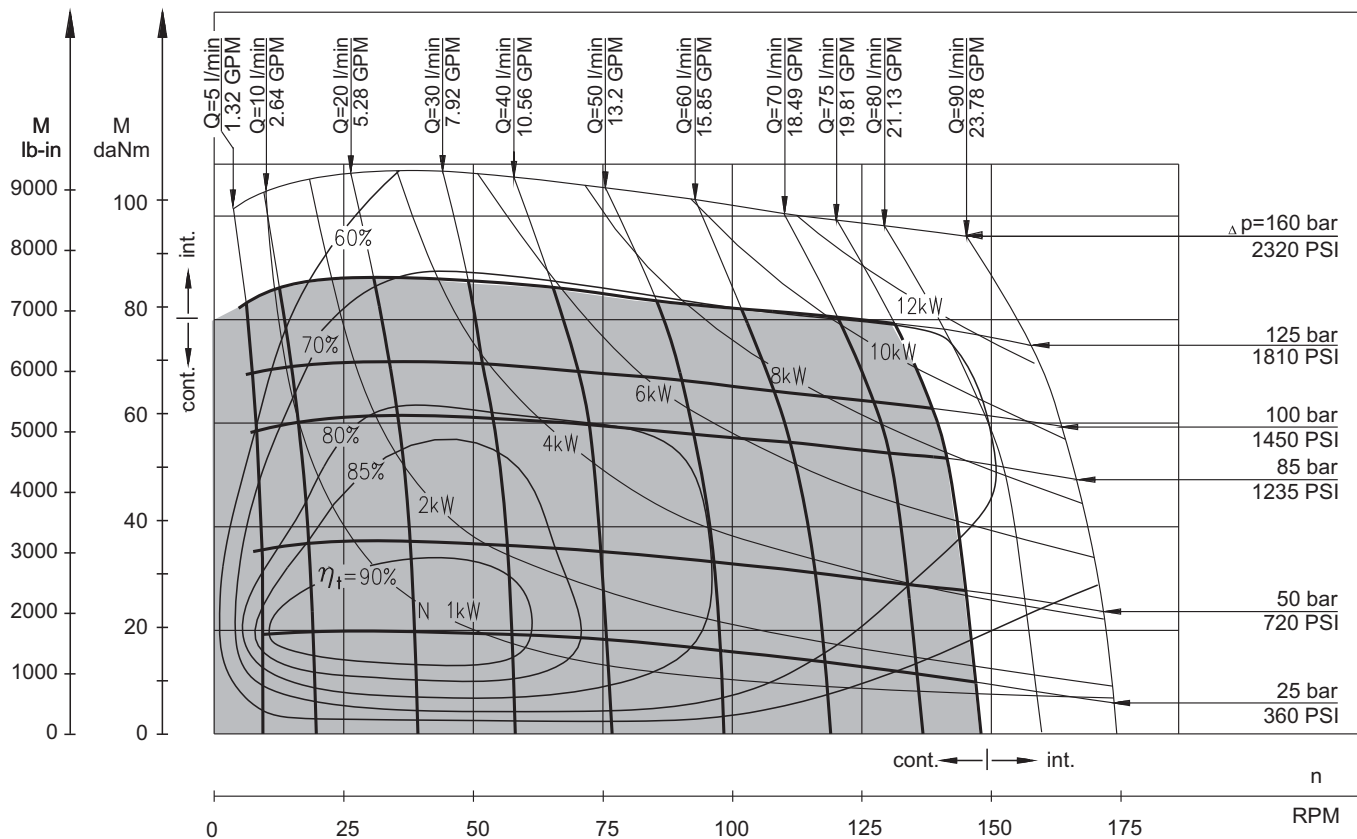

The function diagrams data is for average performance of randomly selected motors at back pressure 5÷10 bar [72.5÷145 PSI] and oil with viscosity of 32 mm<sup>2</sup>/s [150 SUS] at 50°C [122°F].

**PERMISSIBLE SHAFT LOADS FOR MH MOTORS**

The permissible radial shaft load  $P_{rad}$  depends on the speed (RPM) and distance (L) from the point of load to the mounting flange.

$$\text{Radial Shaft Load } P_{rad} = \frac{1100}{n} \times \frac{25000}{103,5+L}, \text{ daN}^*$$

[\*L in mm; L ≤ 60 mm; n ≥ 200 RPM]

$$\text{Radial Shaft Load } P_{rad} = \frac{1100}{\text{RPM}} \times \frac{2215}{4.075+L}, \text{ lbs}^{**}$$

[\*\*L in inch; L ≤ 2.36 in; n ≥ 200 RPM]

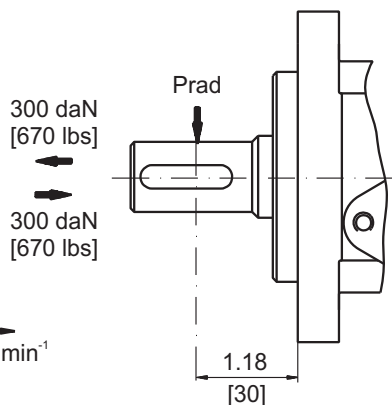
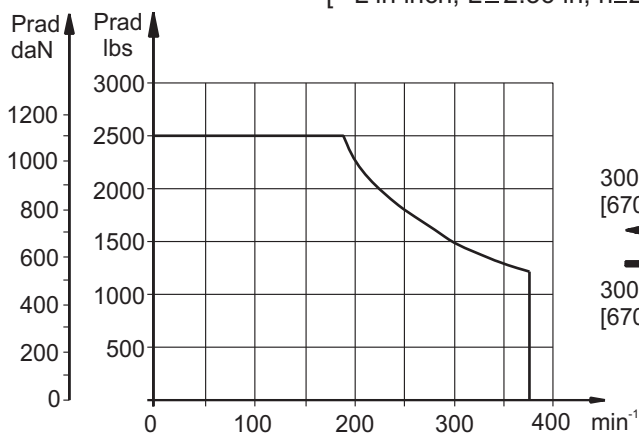

## DIMENSIONS AND MOUNTING DATA

### Magneto Mount (4 holes)

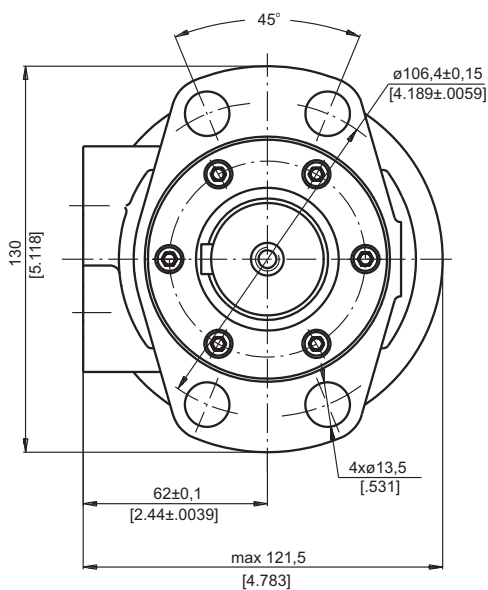
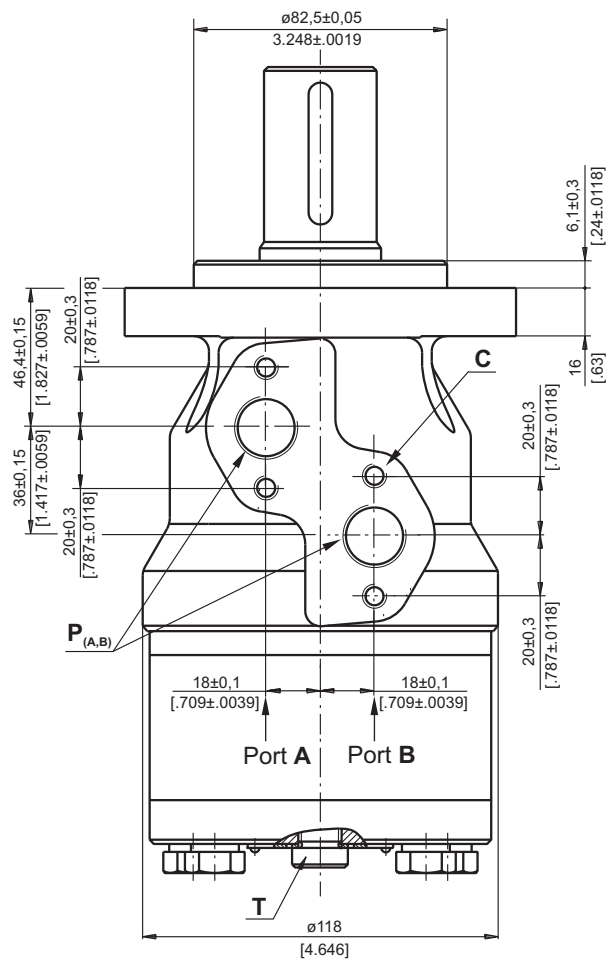
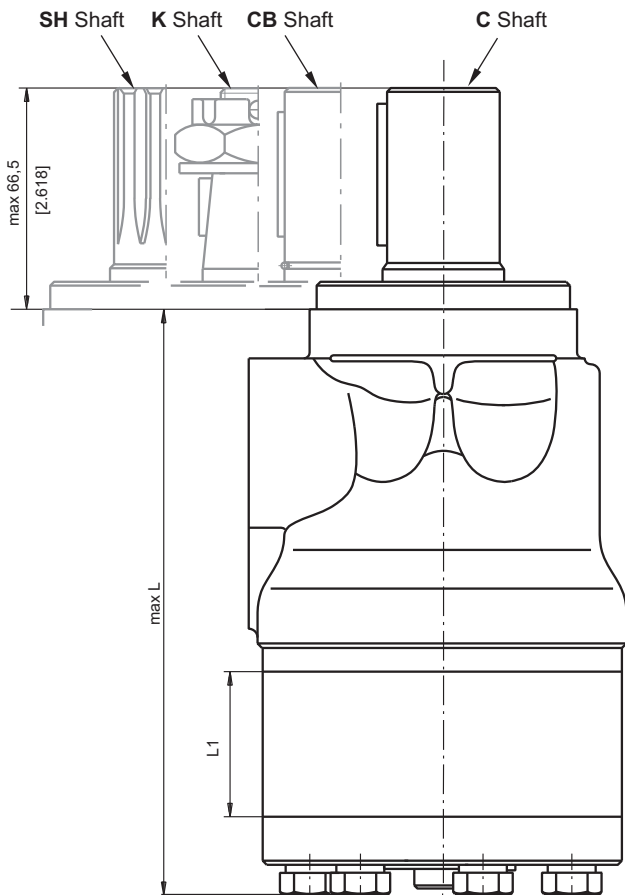

Type	L, mm [in.]	L <sub>1</sub> , mm [in.]
MH 200	169 [6.65]	27,8 [1.09]
MH 250	176 [6.93]	34,8 [1.37]
MH 315	184 [7.24]	43,5 [1.71]
MH 400	196 [7.72]	54,8 [2.16]
MH 500	211 [8.31]	69,4 [2.73]

- C** : 4xM8-13 mm [.51 in] depth  
**P<sub>(A,B)</sub>** : 2xG1/2 or 2xM22x1,5-15 mm [.59 in] depth  
**T** : G1/4 or M14x1,5-12 mm [.47 in] depth (plugged)

#### Standard Rotation

Viewed from Shaft End  
 Port A Pressurized - **CW**  
 Port B Pressurized - **CCW**

#### Reverse Rotation

Viewed from Shaft End  
 Port A Pressurized - **CCW**  
 Port B Pressurized - **CW**



**MAX. PERMISSIBLE SHAFT SEAL PRESSURE FOR MH MOTORS**

**MH...U1 motors with high pressure seal and without drain connection:**

The shaft seal pressure equals the average of input pressure and return pressure.

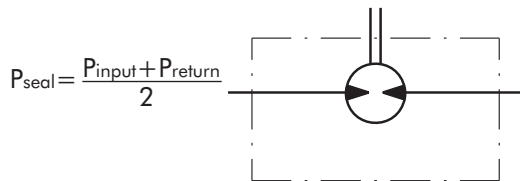

**MH...U motors with high pressure seal and drain connection:**

The shaft seal pressure equals the pressure in the drain line.

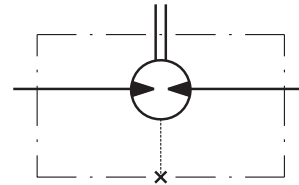

**MH...1 motors with standard shaft seal and without drain connection:**

The shaft seal pressure never exceeds the pressure in the return line.

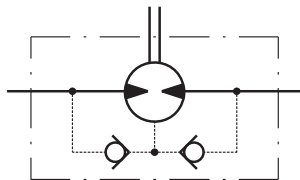

**MH... motors with standard shaft seal and with drain connection:**

The shaft seal pressure equals the pressure in the drain line.

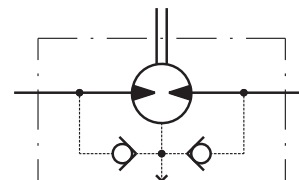

**Max. return pressure without drain line or max. pressure in the drain line**

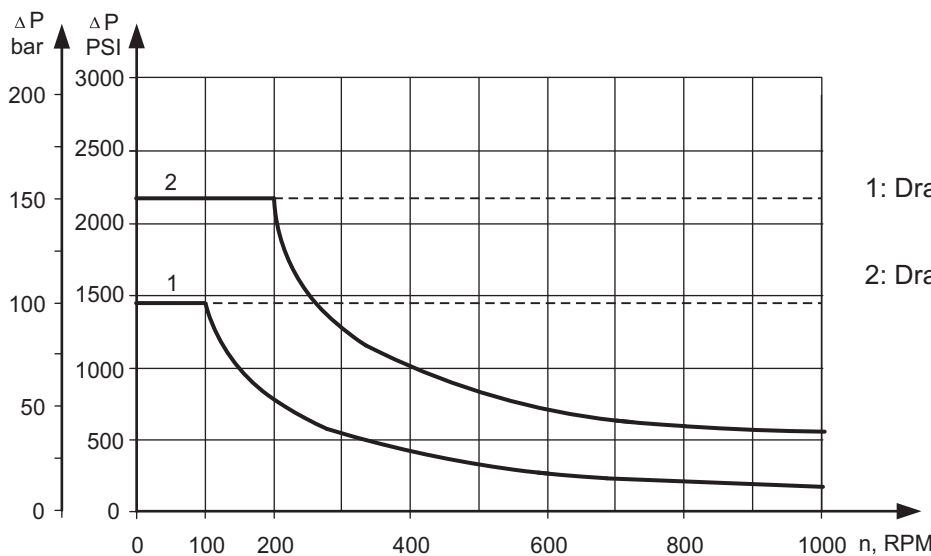

1: Drawing for Standard Shaft Seal

2: Drawing for High Pressure Seal ("U" Seal)

— - continuous operations  
- - - - - intermittent operations

**MOTORS WITH TACHO CONNECTION**

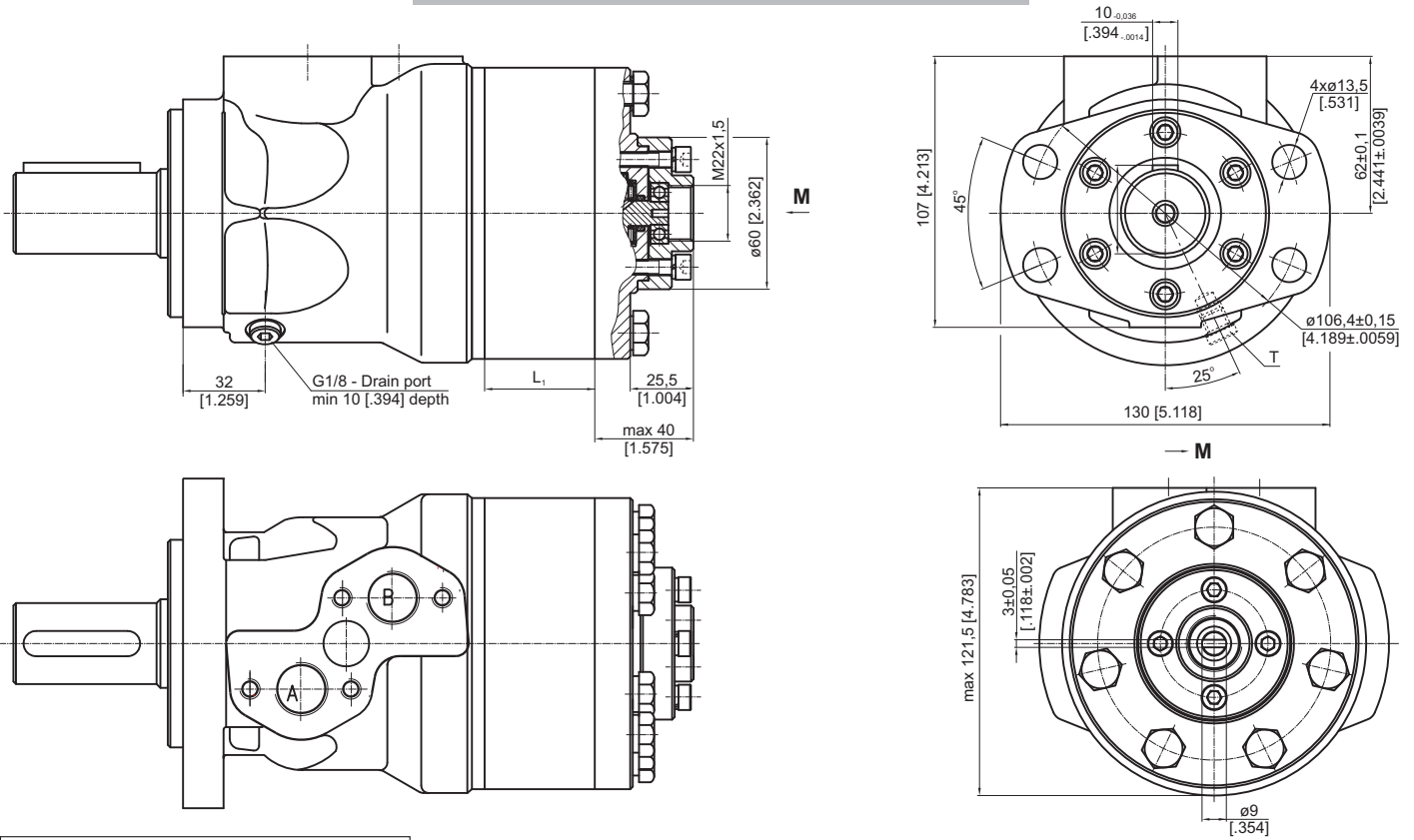

Type	L, mm [in]	L <sub>1</sub> , mm [in]
MH 200	191 [7.52]	27,8 [1.09]
MH 250	198 [7.79]	34,8 [1.37]
MH 315	207 [8.15]	43,5 [1.71]
MH 400	218 [8.58]	54,8 [2.16]
MH 500	233 [9.17]	69,4 [2.73]



**SHAFT EXTENSIONS**

**C** -  $\varnothing 32$  straight, Parallel key A10x8x45 DIN 6885  
Max. Torque 77 daNm [6815 lb-in]

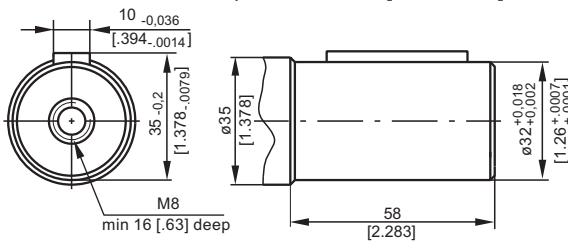

**SH** -  $\varnothing 1\frac{1}{4}$ " splined 14T, DP 12/24 ANSI B92.1-1976  
Max. Torque 95 daNm [8400 lb-in]

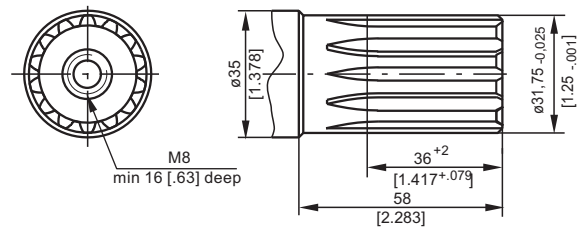

**CB** -  $\varnothing 35$  straight, Parallel key A10x8x45 DIN 6885  
Max. Torque 95 daNm [8400 lb-in]

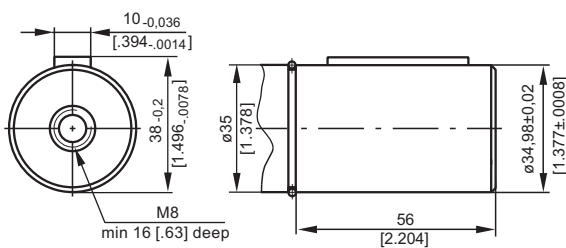

**K** - tapered 1:10, Parallel key B6x6x20 DIN 6885  
Max. Torque 95 daNm [8400 lb-in]

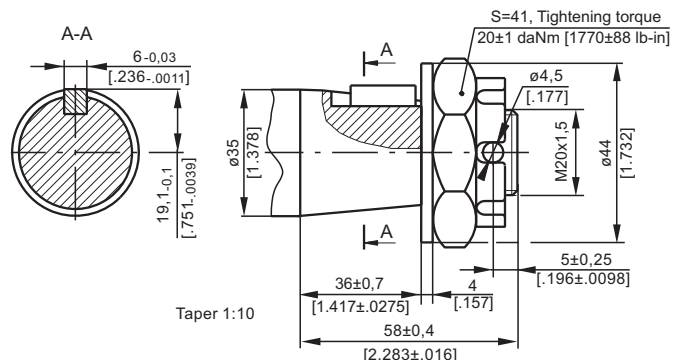

## ORDER CODE

	1	2	3	4	5	6	7
M H							

### Pos.1 - Displacement code

<b>200</b>	- 201,3 cm <sup>3</sup> /rev [12.3 in <sup>3</sup> /rev]
<b>250</b>	- 252,0 cm <sup>3</sup> /rev [15.4 in <sup>3</sup> /rev]
<b>315</b>	- 314,9 cm <sup>3</sup> /rev [16.4 in <sup>3</sup> /rev]
<b>400</b>	- 396,8 cm <sup>3</sup> /rev [24.2 in <sup>3</sup> /rev]
<b>500</b>	- 502,4 cm <sup>3</sup> /rev [30.7 in <sup>3</sup> /rev]

### Pos.2 - Shaft Extensions\*

<b>C</b>	- ø32 straight, Parallel key A10x8x45 DIN 6885
<b>SH</b>	- ø1¼" splined 14T ANSI B92.1-1970
<b>CB**</b>	- ø35 straight, Parallel key A10x8x45 DIN 6885
<b>K</b>	- ø35 tapered 1:10, Parallel key B6x6x20 DIN 6885

### Pos.3 - Shaft Seal Version

omit	- Standard shaft seal
<b>U</b>	- High pressure shaft seal (without check valves)

### Pos.4 - Drain Port

omit	- with drain port
<b>1</b>	- without drain port

### Pos.5 - Ports

omit	- BSPP (ISO 228)
<b>M</b>	- Metric (ISO 262)

### Pos.6 - Special Features (see page 119)

### Pos.7 - Design Series

omit	- Factory specified
------	---------------------

**NOTES:** \* The permissible output torque for shafts must not be exceeded!  
 \*\* The following combination is not allowed: "CB" shaft with U shaft seal.

The hydraulic motors are mangano-phosphatized as standard.

# HYDRAULIC MOTORS HW



## APPLICATION

- » Conveyors
- » Feeding mechanism of robots and manipulators
- » Metal working machines
- » Textile machines
- » Agricultural machines
- » Food industries
- » Grass cutting machinery etc.

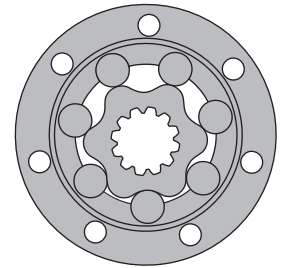

## CONTENTS

Specification data .....103÷104  
 Function diagrams .....105÷111  
 Dimensions and mounting .....112÷115  
 Permissible shaft Seal Pressure ...115  
 Shaft extensions .....116÷117  
 Permissible shaft loads .....117  
 Order code .....118

## OPTIONS

- » Model - Spool valve, roll-gerotor
- » Wheel and flange mount
- » Shafts - straight, splined and tapered
- » BSPP ports
- » Other special features

## GENERAL

<b>Max. Displacement,</b> cm <sup>3</sup> /rev [in <sup>3</sup> /rev]	550 [33.55]
<b>Max. Speed,</b> [RPM]	497
<b>Max. Torque,</b> daNm [in-lb]	cont.: 96 [8500] int.: 105 [9293]
<b>Max. Output,</b> kW [HP]	23,1 [31]
<b>Max. Pressure Drop,</b> bar [PSI]	cont.: 205 [3000] int.: 225 [3260]
<b>Max. Oil Flow,</b> lpm [GPM]	115 [30.4]
<b>Min. Speed,</b> [RPM]	10
<b>Pressure fluid</b>	Mineral based- HLP(DIN 51524) or HM(ISO 6743/4)
<b>Temperature range,</b> °C [°F]	-40÷140 [-40÷284]
<b>Optimal Viscosity range,</b> mm <sup>2</sup> /s [SUS]	20÷75 [98÷347]
<b>Filtration</b>	ISO code 20/16 (Min. recommended fluid filtration of 25 microns)

### Oil flow in drain line

Pressure drop bar [PSI]	Viscosity mm <sup>2</sup> /s [SUS]	Oil flow in drain line lpm [GPM]
100 [1450]	20 [98]	2,5 [.660]
	35 [164]	1,8 [.476]
140 [2030]	20 [98]	3,5 [.925]
	35 [164]	2,8 [.740]

### Pressure Losses

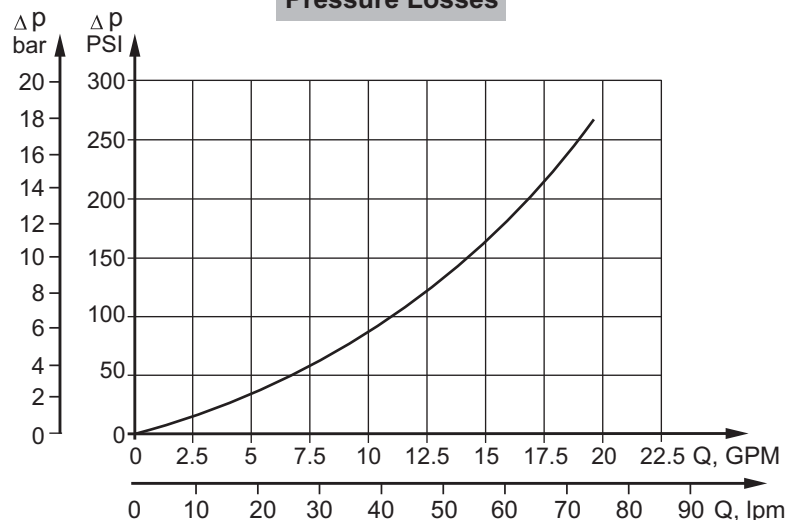

## SPECIFICATION DATA

Type		HW 125	HW 160	HW 200	HW 235	HW 250	HW 300	HW 315
<b>Displacement, cm<sup>3</sup>/rev [in<sup>3</sup>/rev]</b>		126 [7.69]	157,8 [9.64]	201,3 [12.28]	235,3 [14.33]	252 [15.37]	300 [18.3]	314,9 [19.21]
<b>Max. Speed, [RPM]</b>	cont.	357	380	373	319	298	250	238
	int.*	476	475	497	425	397	333	318
<b>Max. Torque daNm [in-lb]</b>	cont.	35 [3098]	44 [3894]	55 [4868]	64,5 [5710]	69 [6107]	81 [7170]	85 [7523]
	int.*	38,5 [3408]	48 [4248]	60 [5310]	70 [6196]	75 [6638]	89 [7877]	93 [8230]
<b>Max. Output, kW [HP]</b>	cont.	16,2 [21.7]	17,6 [23.6]	18,6 [24.9]	18,2 [24.4]	16,8 [22.5]	16,5 [22]	16,4 [21.9]
	int.*	19,8 [26.6]	21,6 [29]	23,1 [31]	22,6 [30.3]	20,8 [27.9]	20,8 [27.9]	20,8 [27.9]
<b>Max. Pressure Drop, bar [PSI]</b>	cont.	205 [2970]	205 [2970]	205 [2970]	205 [2970]	205 [2970]	205 [2970]	205 [2970]
	int.*	225 [3260]	225 [3260]	225 [3260]	225 [3260]	225 [3260]	225 [3260]	225 [3260]
<b>Max. Oil Flow lpm [GPM]</b>	cont.	45 [12]	60 [16]	75 [20]	75 [20]	75 [20]	75 [20]	75 [20]
	int.*	60 [16]	75 [20]	100 [26.4]	100 [26.4]	100 [26.4]	100 [26.4]	100 [26.4]
<b>Max. Inlet Pressure, bar [PSI]</b>	cont.	210 [3050]	210 [3050]	210 [3050]	210 [3050]	210 [3050]	210 [3050]	210 [3050]
	int.*	250 [3625]	250 [3625]	250 [3625]	250 [3625]	250 [3625]	250 [3625]	250 [3625]
<b>Max. Starting Pressure with Unloaded Shaft, bar [PSI]</b>		10 [145]	10 [145]	10 [145]	10 [145]	10 [145]	10 [145]	10 [145]
<b>Min. Starting Torque daNm [in-lb]</b>	at max. press. drop cont.	28,7 [2540]	36 [3186]	45,1 [3991]	52,8 [4673]	56,5 [5000]	66,4 [5877]	69,7 [6169]
	at max. press. drop int.*	31,5 [2788]	39,3 [3478]	49,2 [4355]	57,4 [5080]	61,5 [5443]	72,9 [6452]	76,2 [6744]
<b>Min. Speed**, [RPM]</b>		10	10	10	10	10	10	10
<b>Weight, avg. kg [lb]</b>	HW	14,3 [31.5]	14,6 [32.2]	15,1 [33.3]	15,5 [34.2]	15,7 [34.6]	16,1 [35.5]	16,3 [35.9]
	HWF	12,8 [28.2]	13,1 [28.9]	13,6 [30]	14,0 [30.9]	14,2 [31.3]	14,6 [32.2]	14,8 [32.6]
	HWS	14 [30.9]	14,3 [31.5]	14,8 [32.6]	15,2 [33.5]	15,4 [34]	15,8 [34.8]	16 [35.3]

\* Intermittent operation: the permissible values may occur for max. 10% of every minute.

\*\* For speeds lower than given, consult factory or your regional manager.

- Intermittent speed and intermittent pressure drop must not occur simultaneously.
- Recommended filtration is per ISO cleanliness code 20/16. A nominal filtration of 25 micron or better.
- Recommend using a premium quality, anti-wear type mineral based hydraulic oil HLP(DIN51524) or HM (ISO 6743/4). If using synthetic fluids consult the factory for alternative seal materials.
- Recommended minimum oil viscosity 13 mm<sup>2</sup>/s [70 SUS] at 50°C [122°F].
- Recommended maximum system operating temperature is 82°C [180°F].
- To assure optimum motor life fill with fluid prior to loading and run at moderate load and speed for 10-15 minutes.

## SPECIFICATION DATA

Type		HW 350	HW 370	HW 400	HW 470	HW 500	HW 535	HW 550
<b>Displacement, cm<sup>3</sup>/rev [in<sup>3</sup>/rev]</b>		347,8 [21.21]	369,2 [22.51]	396,8 [24.2]	470,6 [28.71]	502,4 [30.65]	535 [32.7]	550 [33.55]
<b>Max. Speed, [RPM]</b>	cont.	216	203	189	159	149	140	136
	int.*	288	271	252	244	229	215	209
<b>Max. Torque daNm [in-lb]</b>	cont.	94 [8320]	96 [8497]	96 [8497]	92 [8143]	91 [8054]	90 [7966]	89 [7877]
	int.*	102 [9028]	105 [9293]	98 [8674]	101 [8939]	101 [8939]	104 [9205]	105 [9293]
<b>Max. Output, kW [HP]</b>	cont.	16,5 [22]	13,2 [17.7]	12,5 [16.8]	10,6 [14.2]	10,8 [14.5]	9,4 [12.6]	9 [12]
	int.*	20,8 [27.9]	19,2 [25.7]	18,5 [24.8]	17,4 [23.3]	17,8 [23.9]	16,4 [22]	15,8 [21.2]
<b>Max. Pressure Drop, bar [PSI]</b>	cont.	205 [2970]	205 [2970]	185 [2680]	150 [2180]	140 [2030]	130 [1885]	125 [1815]
	int.*	225 [3260]	225 [3260]	190 [2760]	165 [2390]	155 [2250]	150 [2180]	145 [2105]
<b>Max. Oil Flow lpm [GPM]</b>	cont.	75 [20]	75 [20]	75 [20]	75 [20]	75 [20]	75 [20]	75 [20]
	int.*	100 [26.4]	100 [26.4]	100 [26.4]	115 [30.4]	115 [30.4]	115 [30.4]	115 [30.4]
<b>Max. Inlet Pressure, bar [PSI]</b>	cont.	210 [3050]	210 [3050]	210 [3050]	210 [3050]	210 [3050]	210 [3050]	210 [3050]
	int.*	250 [3625]	250 [3625]	250 [3625]	250 [3625]	250 [3625]	250 [3625]	250 [3625]
<b>Max. Starting Pressure with Unloaded Shaft, bar [PSI]</b>		10 [145]	10 [145]	10 [145]	10 [145]	10 [145]	10 [145]	10 [145]
<b>Min. Starting Torque daNm [in-lb]</b>	at max. press. drop cont.	77 [6815]	79,5 [7036]	78,7 [6966]	75,4 [6674]	74,6 [6603]	73,8 [6532]	72,9 [6452]
	at max. press. drop int.*	83,6 [7400]	86 [7612]	80,3 [7107]	82,8 [7328]	82,8 [7328]	85,2 [7540]	84,4 [7470]
<b>Min. Speed**, [RPM]</b>		8	8	8	8	8	5	5
<b>Weight, avg. kg [lb]</b>	HW	16,7 [36.8]	16,9 [37.3]	17,3 [38.1]	18,1 [39.9]	18,4 [40.6]	18,8 [41.5]	18,9 [41.7]
	HWF	15,2 [33.5]	15,4 [34]	15,8 [34.8]	16,6 [36.6]	16,9 [37.3]	17,3 [38.1]	17,4 [38.3]
	HWS	16,4 [36.2]	16,6 [36.6]	17 [37.5]	17,8 [39.2]	18,1 [39.9]	18,5 [40.8]	18,6 [41]

\* Intermittent operation: the permissible values may occur for max. 10% of every minute.

\*\* For speeds lower than given, consult factory or your regional manager.

- Intermittent speed and intermittent pressure drop must not occur simultaneously.
- Recommended filtration is per ISO cleanliness code 20/16. A nominal filtration of 25 micron or better.
- Recommend using a premium quality, anti-wear type mineral based hydraulic oil HLP(DIN51524) or HM (ISO 6743/4).  
If using synthetic fluids consult the factory for alternative seal materials.
- Recommended minimum oil viscosity 13 mm<sup>2</sup>/s [70 SUS] at 50°C [122°F].
- Recommended maximum system operating temperature is 82°C [180°F].
- To assure optimum motor life fill with fluid prior to loading and run at moderate load and speed for 10-15 minutes.

**FUNCTION DIAGRAMS**

**HW 125**

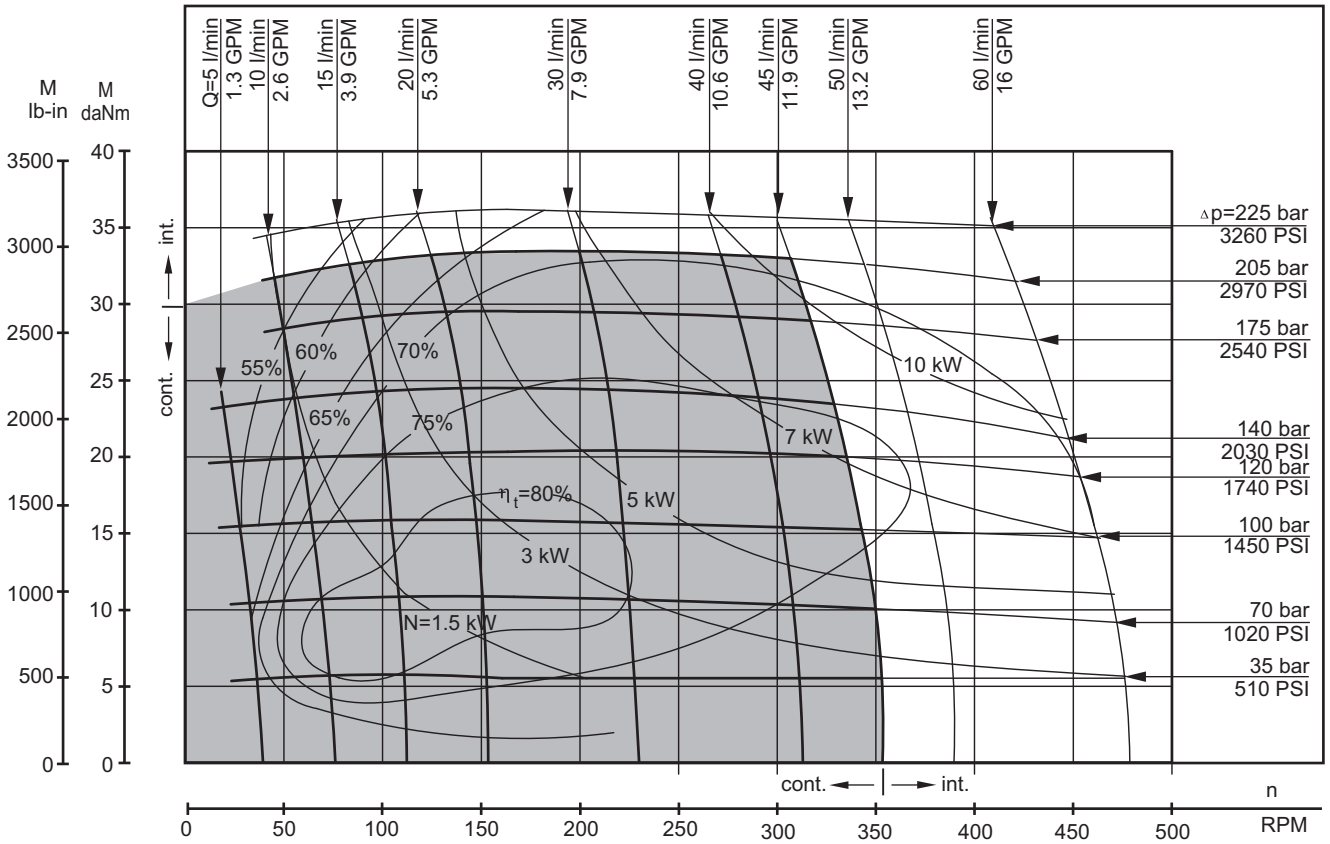

**HW 160**

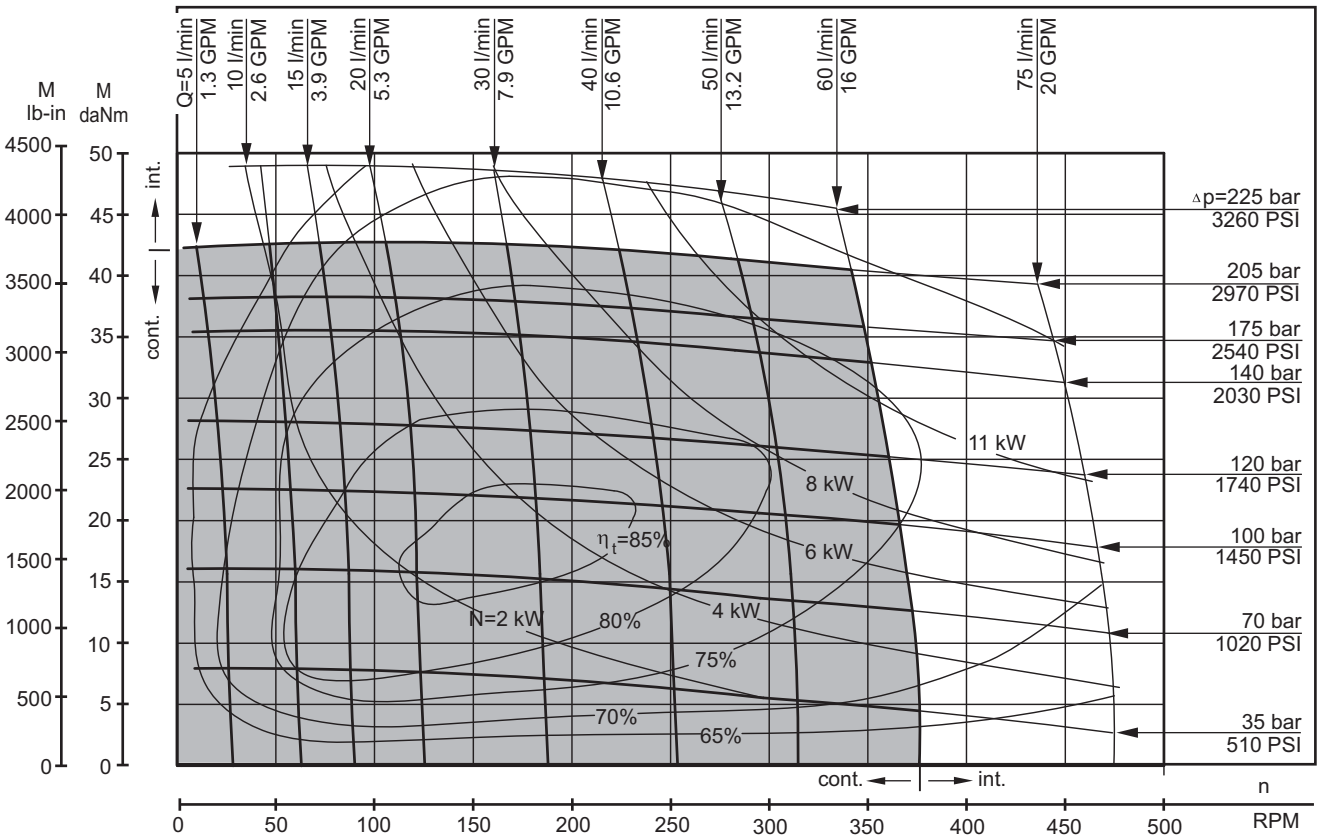

The function diagrams data is for average performance of randomly selected motors at back pressure  $5 \div 10$  bar [72.5  $\div$  145 PSI] and oil with viscosity of 32 mm<sup>2</sup>/s [150 SUS] at 50°C [122°F].

**FUNCTION DIAGRAMS**

**HW 200**

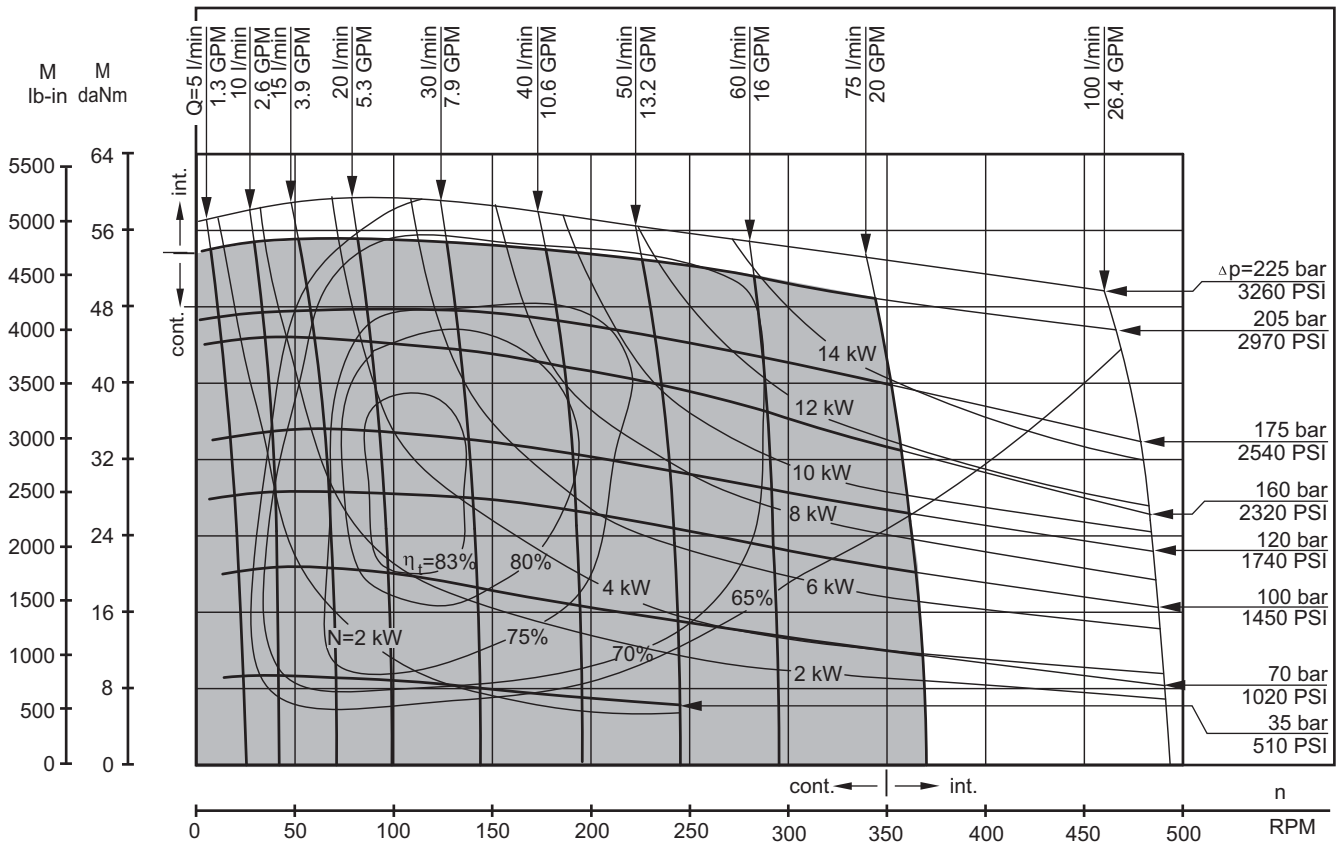

**HW 235**

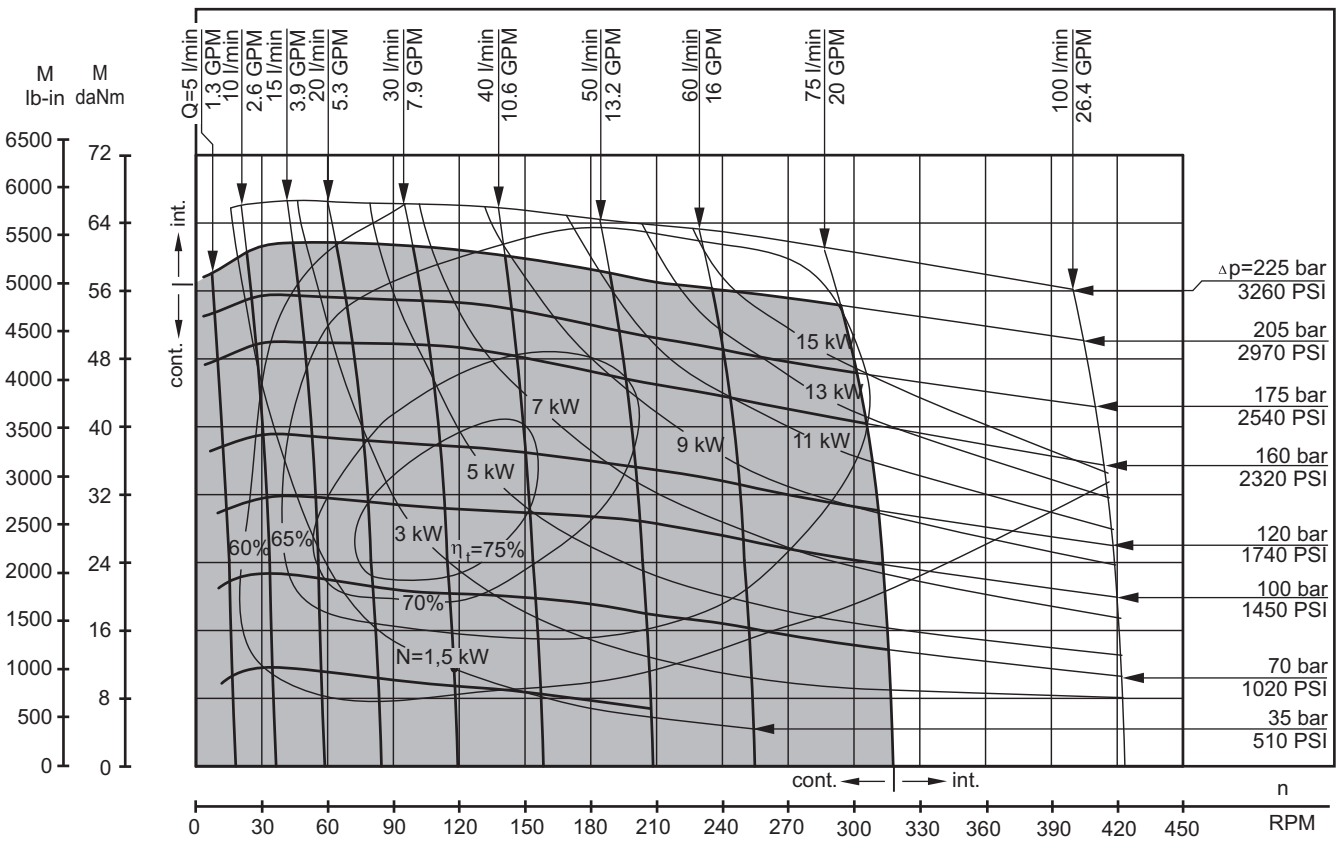

The function diagrams data is for average performance of randomly selected motors at back pressure 5÷10 bar [72.5÷145 PSI] and oil with viscosity of 32 mm<sup>2</sup>/s [150 SUS] at 50°C [122°F].

**FUNCTION DIAGRAMS**

**HW 250**

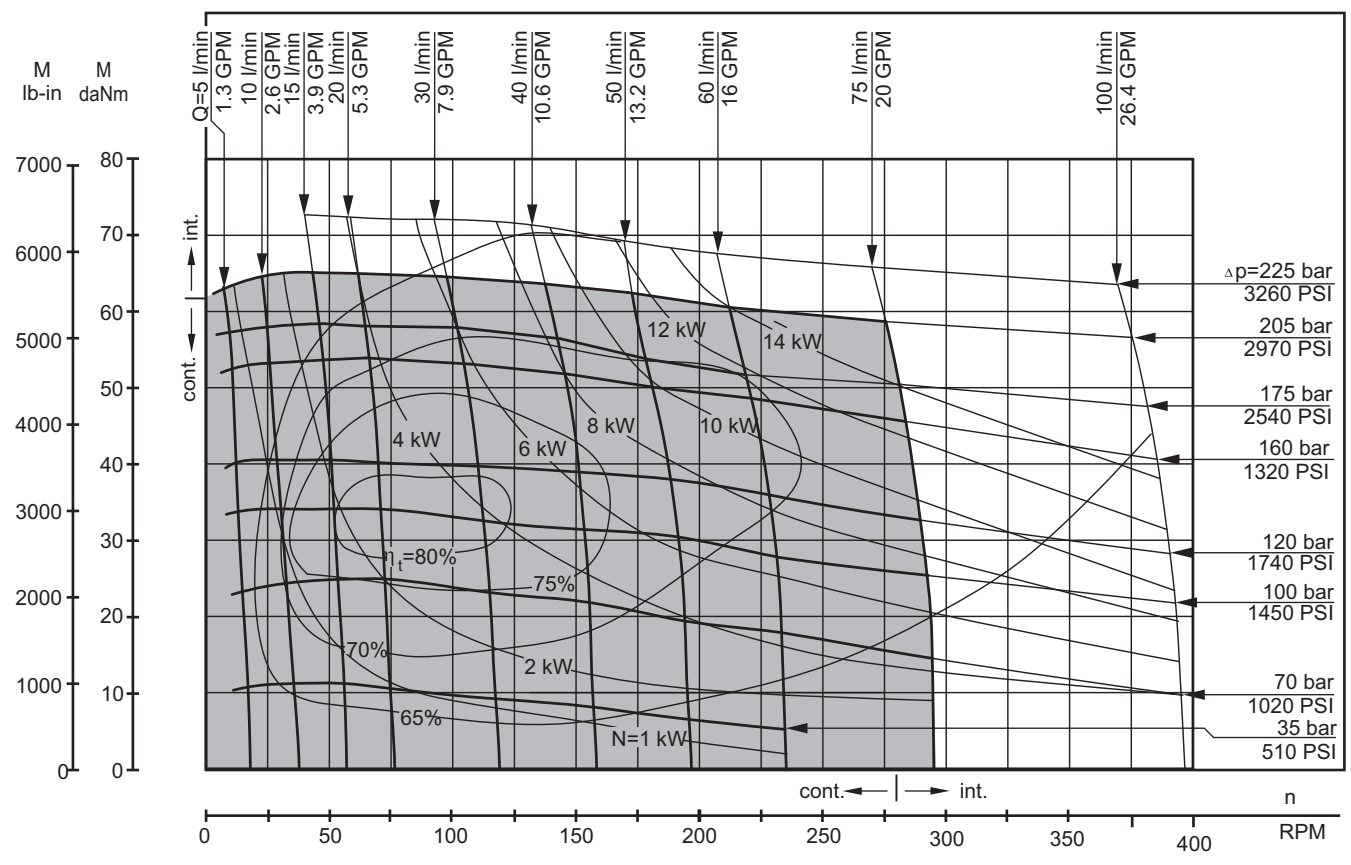

**HW 300**

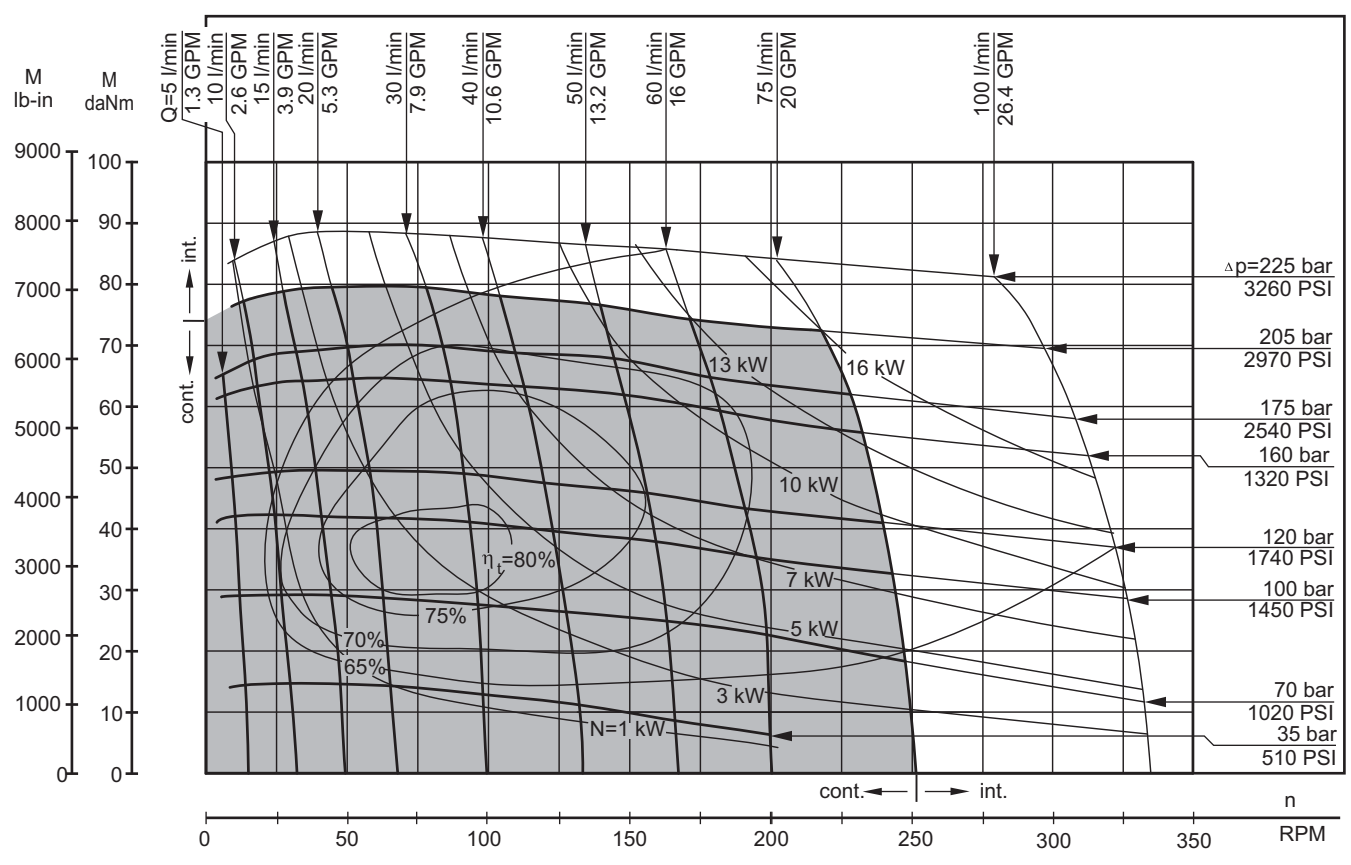

The function diagrams data is for average performance of randomly selected motors at back pressure 5÷10 bar [72.5÷145 PSI] and oil with viscosity of 32 mm<sup>2</sup>/s [150 SUS] at 50°C [122°F].

**FUNCTION DIAGRAMS**

**HW 315**

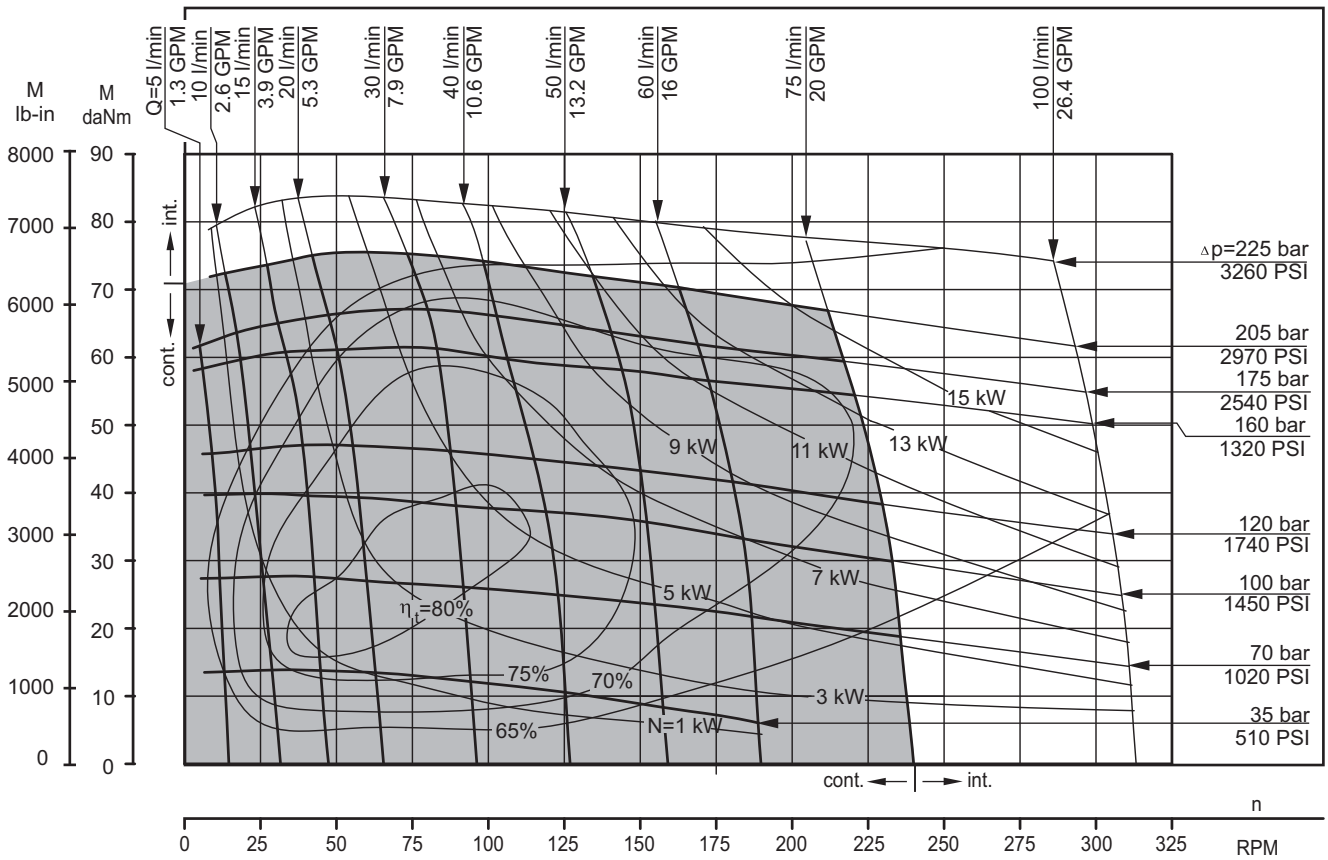

**HW 350**

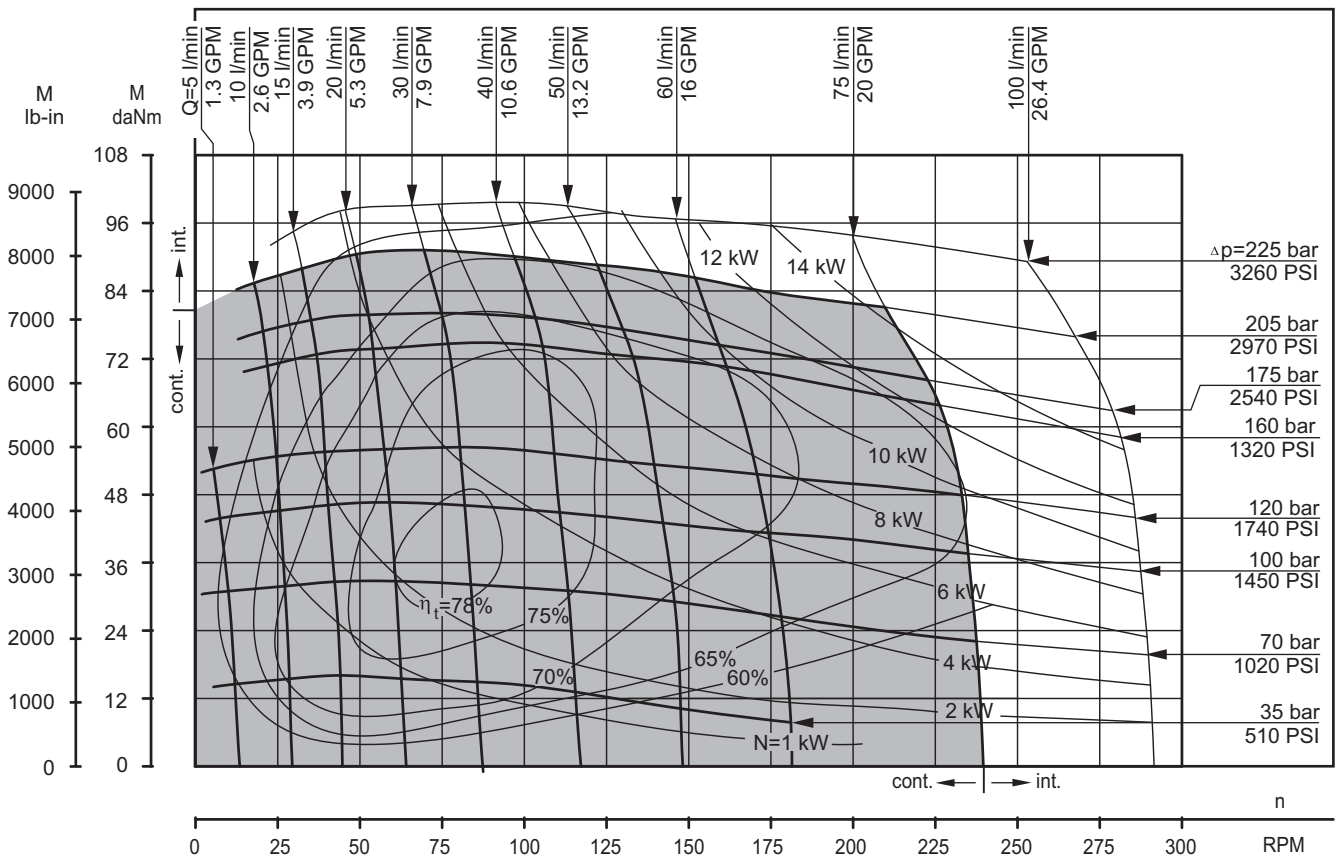

The function diagrams data is for average performance of randomly selected motors at back pressure  $5 \div 10$  bar [72.5  $\div$  145 PSI] and oil with viscosity of 32 mm<sup>2</sup>/s [150 SUS] at 50°C [122°F].

**FUNCTION DIAGRAMS**

**HW 370**

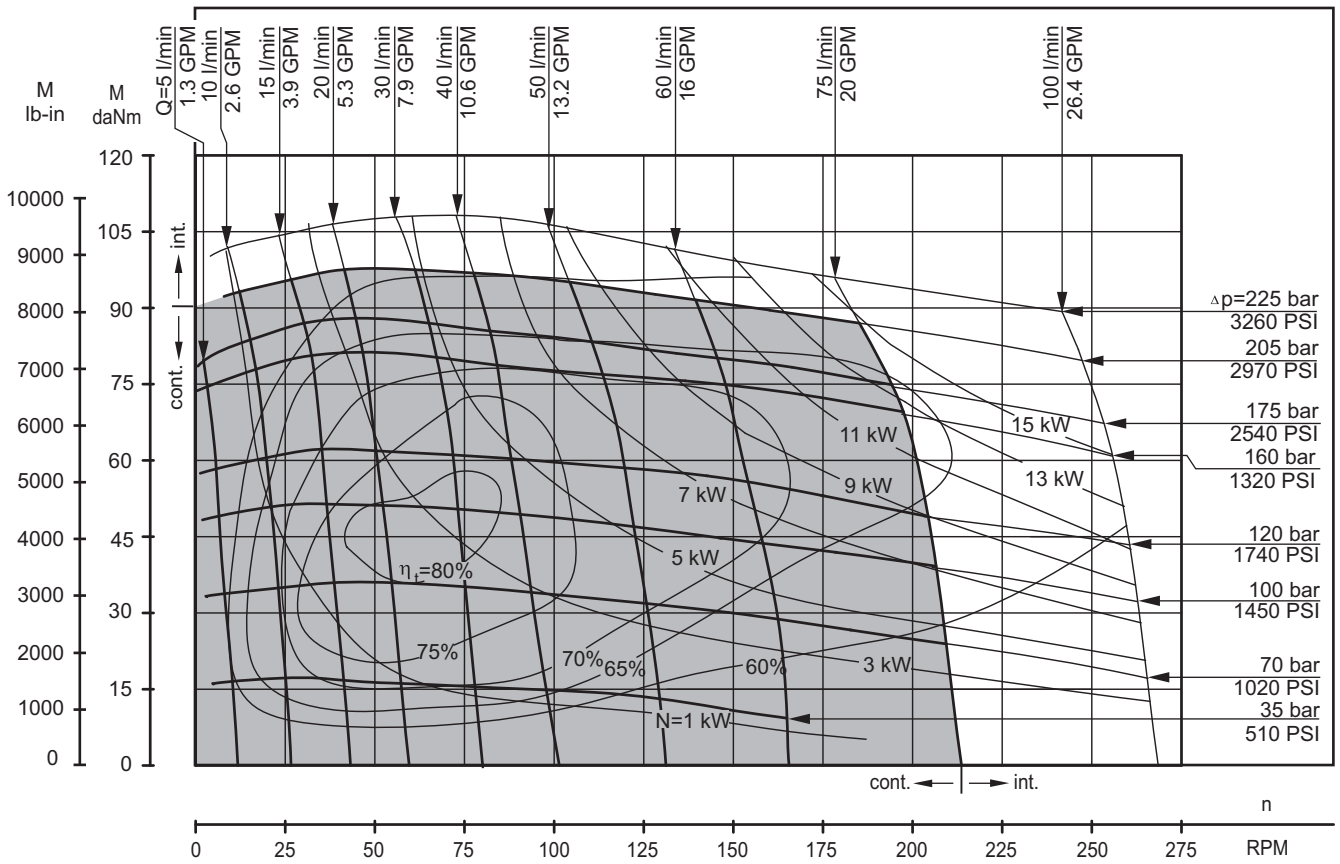

**HW 400**

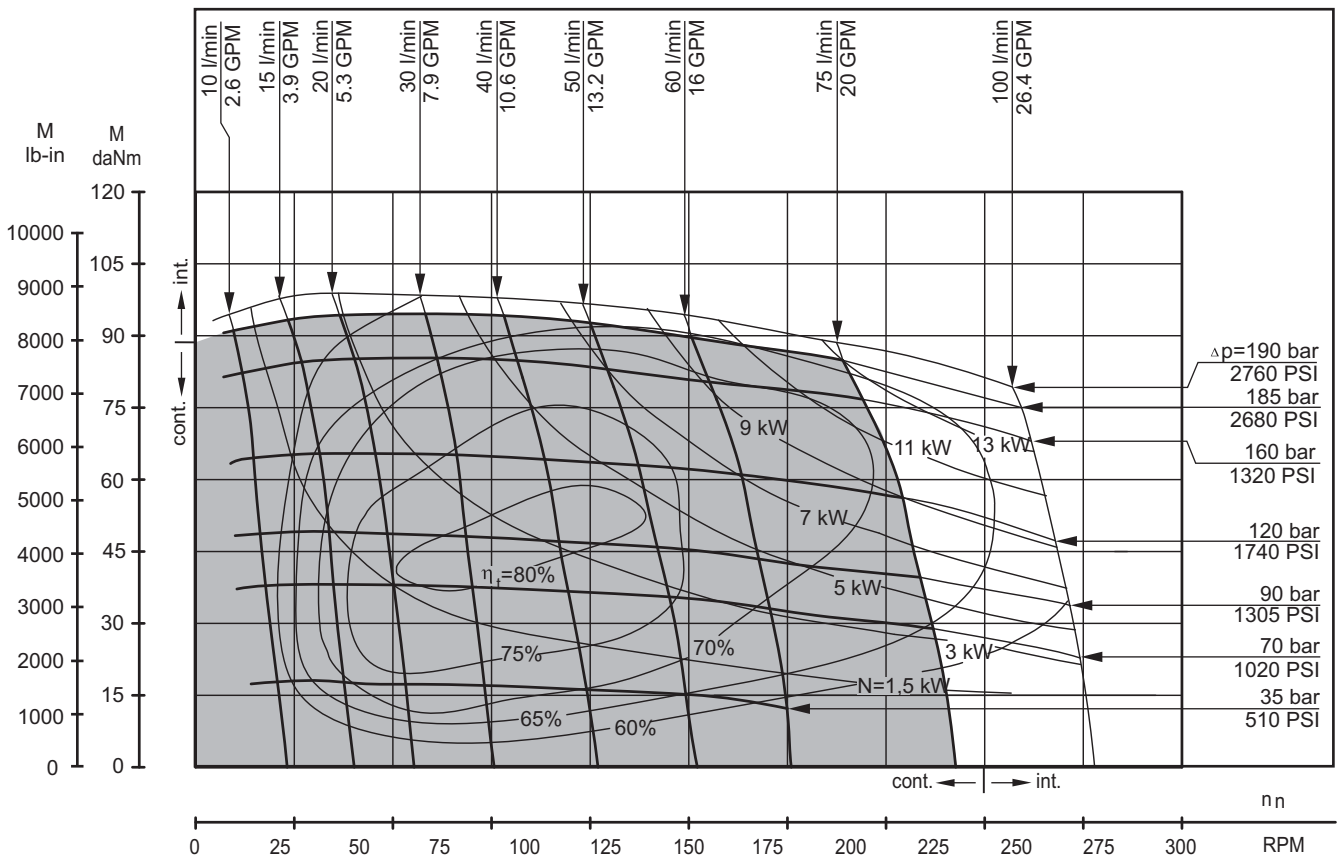

The function diagrams data is for average performance of randomly selected motors at back pressure  $5 \div 10$  bar [72.5  $\div$  145 PSI] and oil with viscosity of 32 mm<sup>2</sup>/s [150 SUS] at 50°C [122°F].

**FUNCTION DIAGRAMS**

**HW 470**

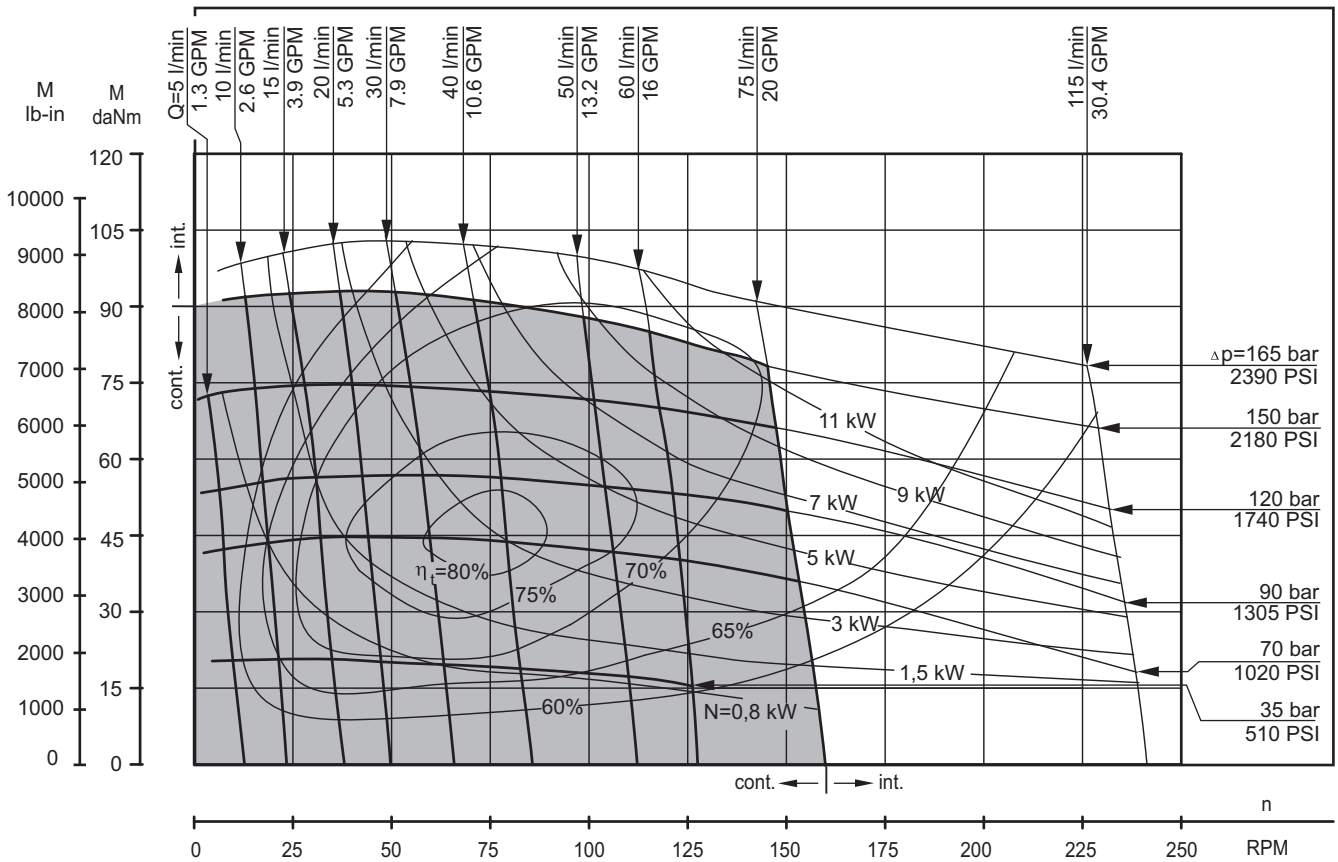

**HW 500**

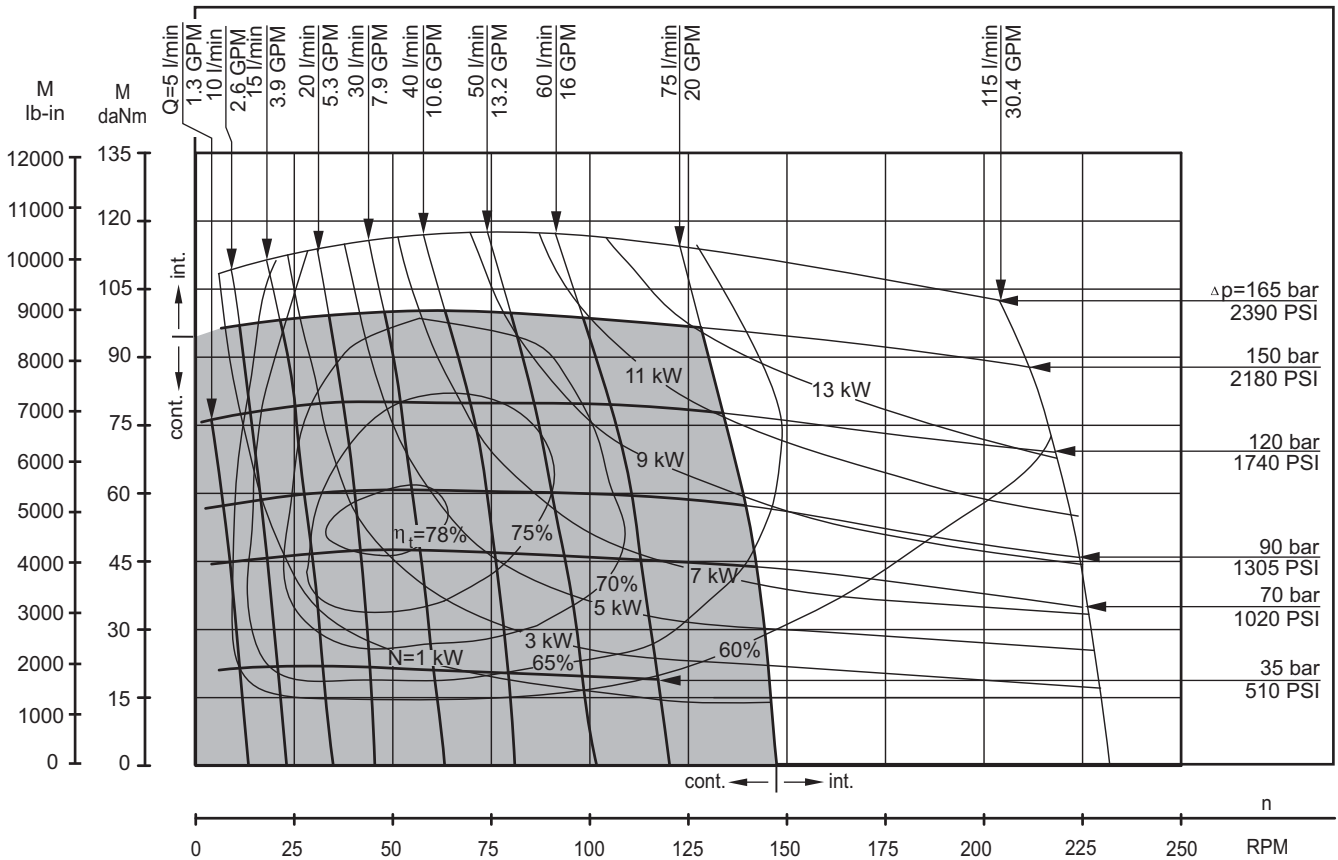

The function diagrams data is for average performance of randomly selected motors at back pressure 5÷10 bar [72.5÷145 PSI] and oil with viscosity of 32 mm<sup>2</sup>/s [150 SUS] at 50°C [122°F].

**FUNCTION DIAGRAMS**

**HW 535**

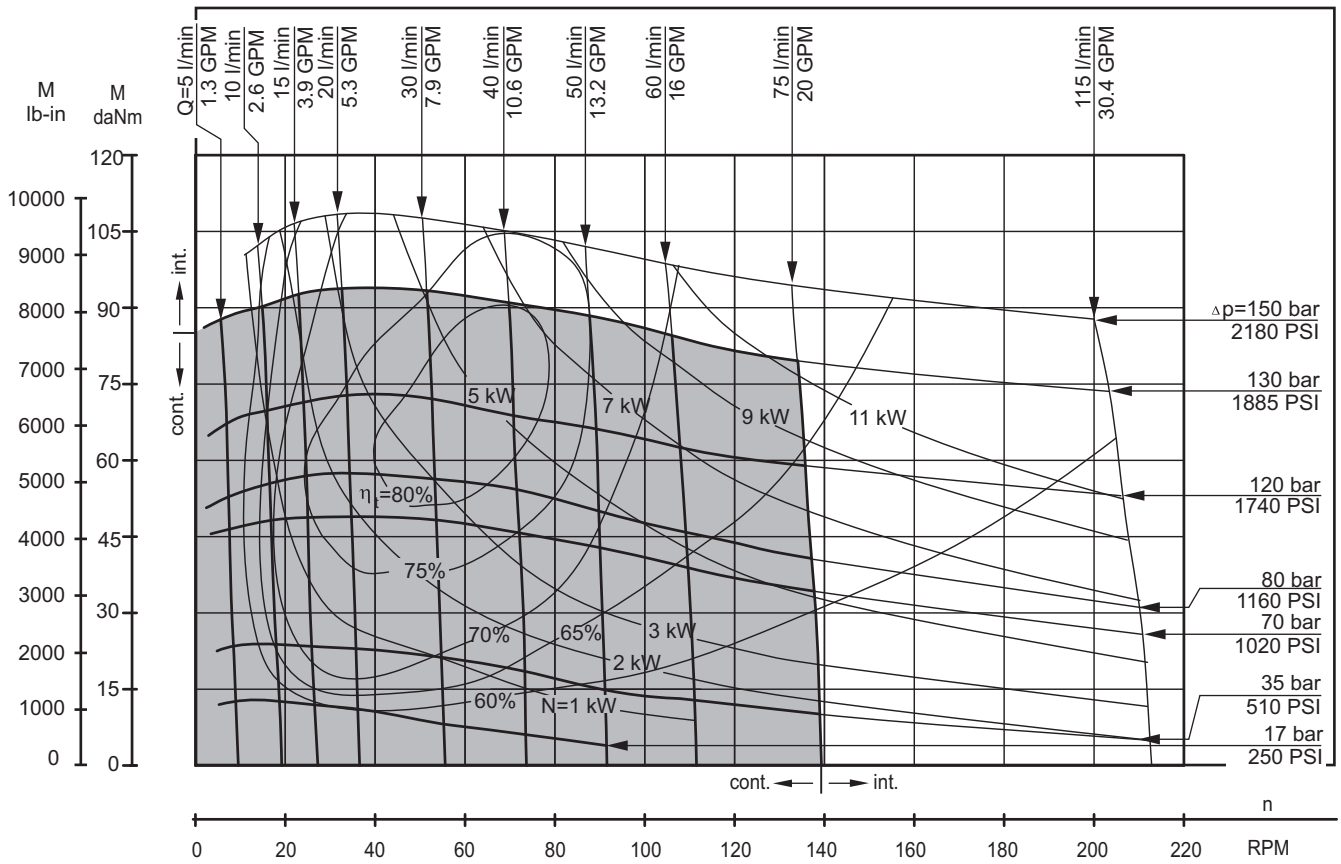

**HW 550**

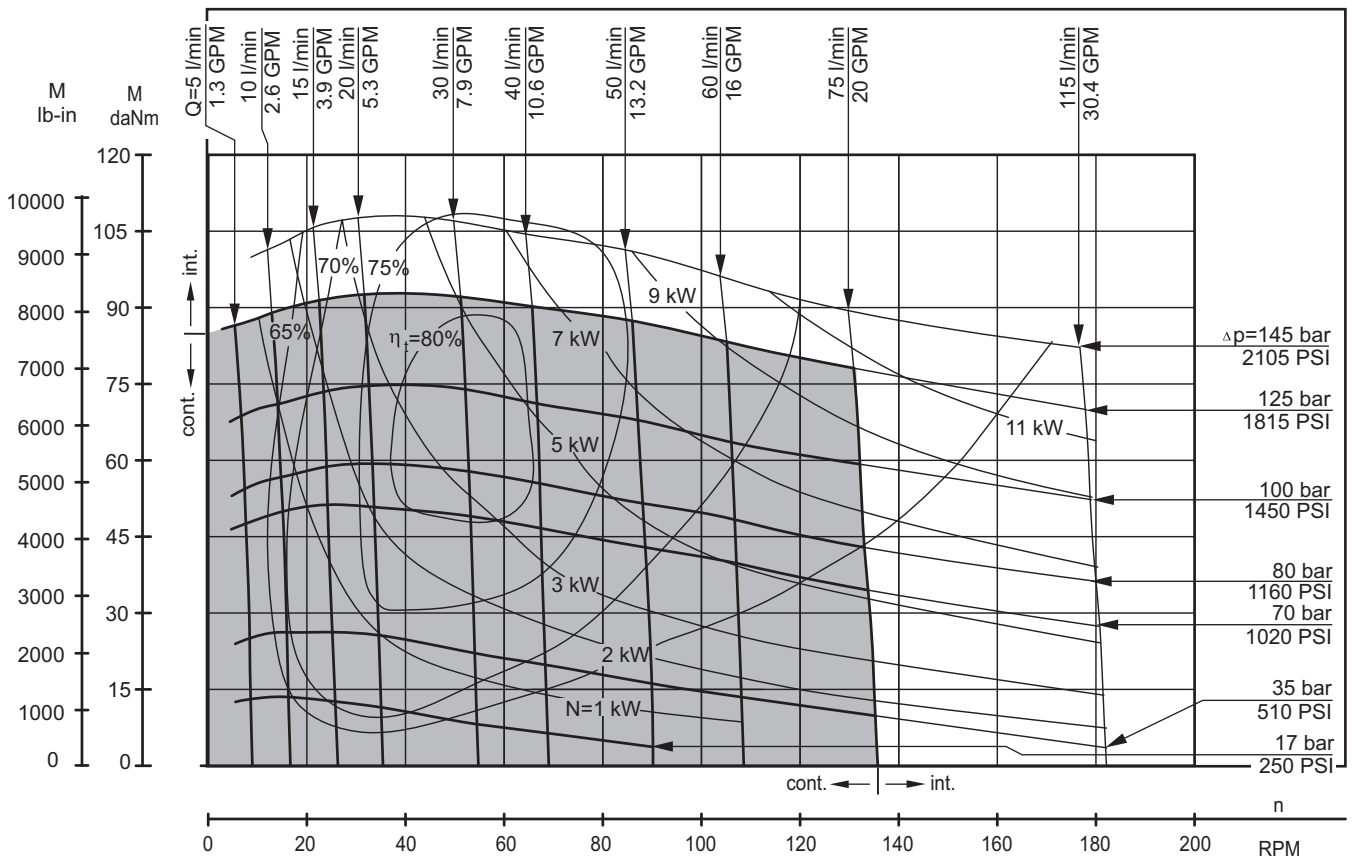

The function diagrams data is for average performance of randomly selected motors at back pressure 5÷10 bar [72.5÷145 PSI] and oil with viscosity of 32 mm<sup>2</sup>/s [150 SUS] at 50°C [122°F].

**DIMENSIONS AND MOUNTING DATA**

**HW - Wheel Mount**

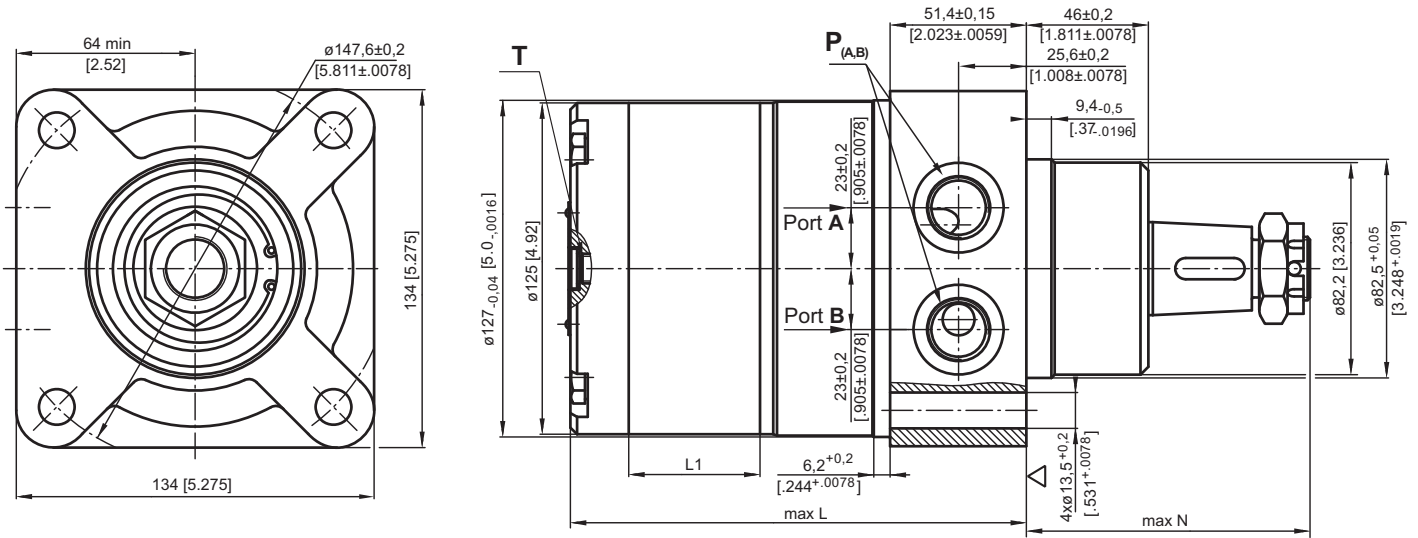

**HWS - Wheel Mount**

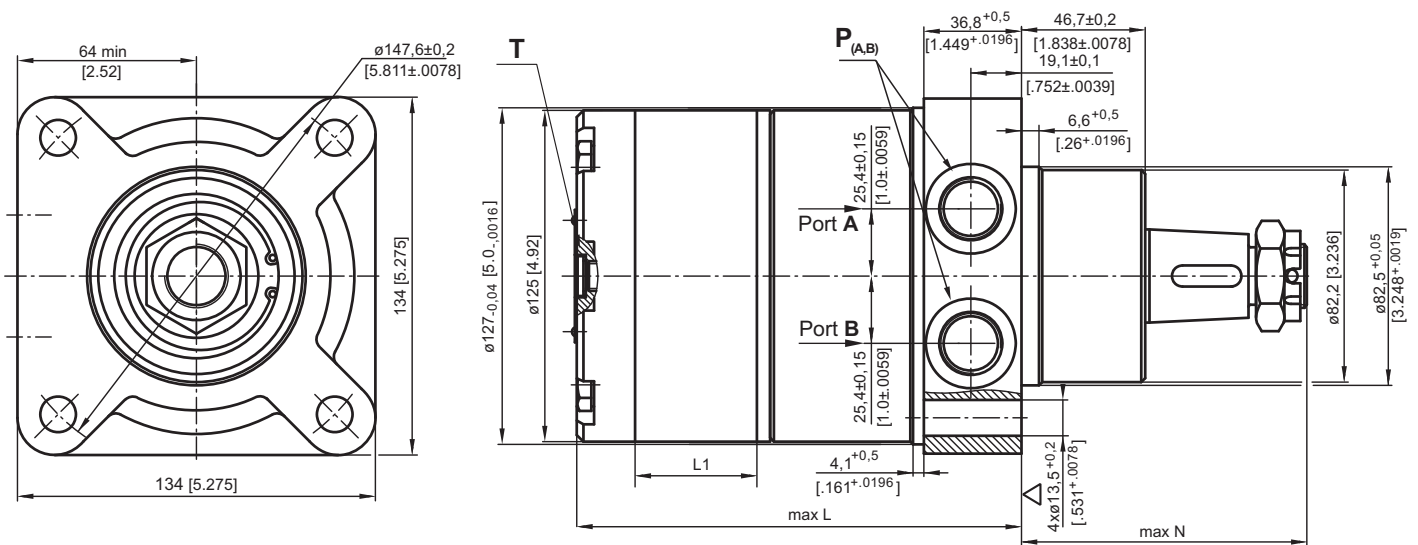

Type	*L, mm [in.]	L <sub>1</sub> , mm [in.]
HW 125	140,5 [5.51]	17,4 [.68]
HW 160	145,0 [5.71]	21,8 [.86]
HW 200	151,0 [5.95]	27,8 [1.09]
HW 235	155,5 [6.12]	32,5 [1.28]
HW 250	158,0 [6.22]	34,8 [1.37]
HW 300	164,5 [6.48]	41,4 [1.63]
HW 315	166,5 [6.56]	43,5 [1.71]
HW 350	171,0 [6.73]	48,0 [1.89]
HW 370	174,0 [6.85]	51,0 [2.01]
HW 400	178,0 [7.01]	54,8 [2.16]
HW 470	188,0 [7.40]	65,0 [2.56]
HW 500	192,5 [7.58]	69,4 [2.73]
HW 535	197,0 [7.76]	74,1 [2.92]
HW 550	199,0 [7.84]	76,0 [2.99]

▽ - Motor Mounting Surface

	Versions	
	2	4
P <sub>(A,B)</sub>	2xG $\frac{1}{2}$	2x $\frac{7}{8}$ -14UNF, O-ring
T	G $\frac{1}{4}$	$\frac{7}{16}$ -20UNF, O-ring

**Note:** For N see pages 116 and 117.

**Standard Rotation**

Viewed from Shaft End

Port A Pressurized - **CW**

Port B Pressurized - **CCW**

**Reverse Rotation**

Viewed from Shaft End

Port A Pressurized - **CCW**

Port B Pressurized - **CW**



\* For LSV option the dimension L is 3 mm [1.18 in] greater.

**DIMENSIONS AND MOUNTING DATA**

**HWSR** - Wheel mount, relief valves

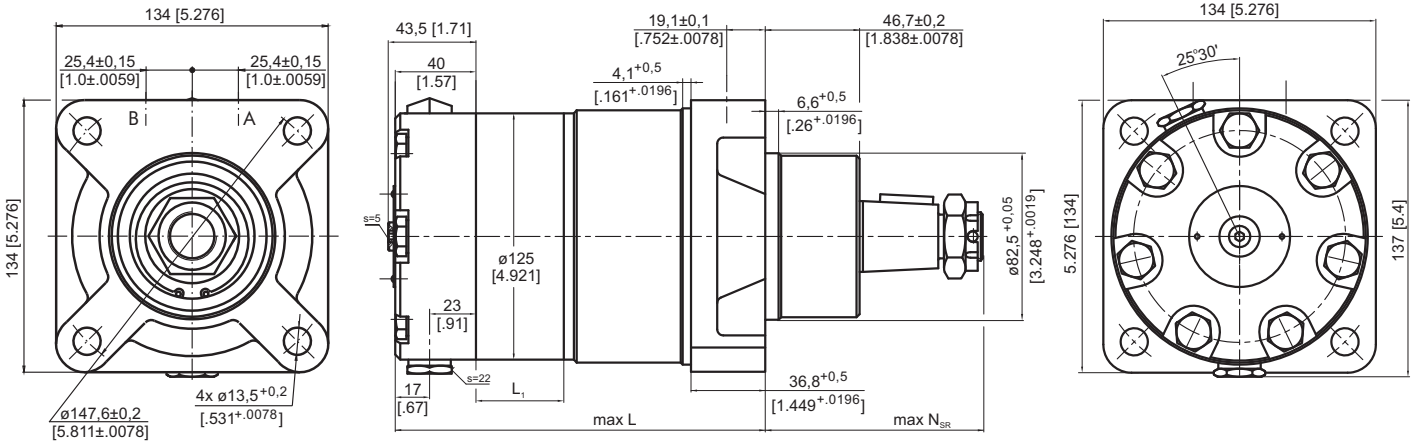

**HWFR** - Wheel mount, six holes, relief valves

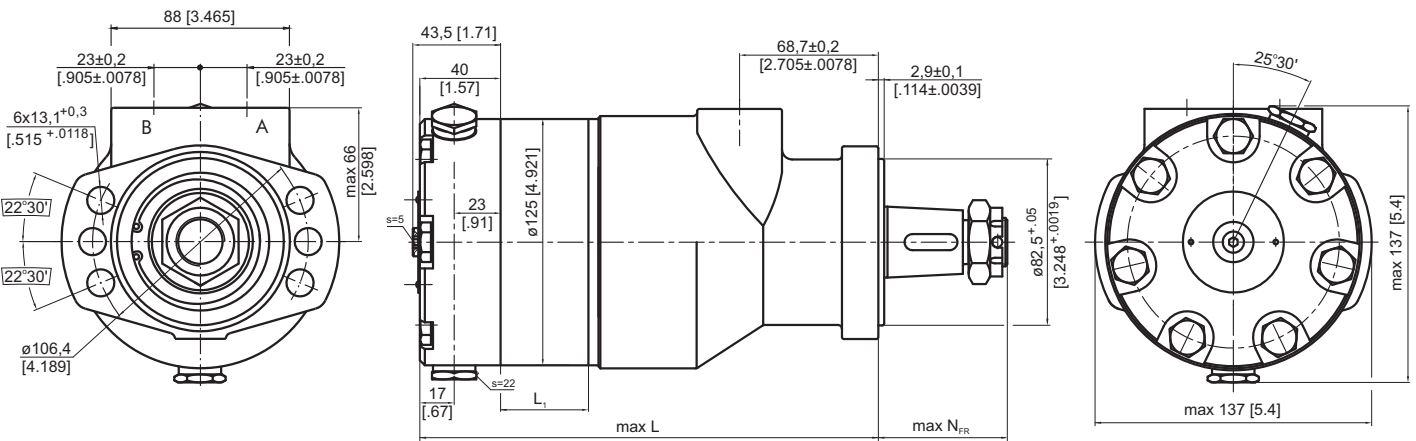

Type	*L, mm [in]		L <sub>1</sub> , mm [in]
	HWSR	HWFR	
HW... 125	158,5 [6.24]	202,0 [7.95]	17,4 [.68]
HW... 160	163,0 [6.42]	206,5 [8.13]	21,8 [.86]
HW... 200	169,0 [6.65]	212,5 [8.37]	27,8 [1.09]
HW... 235	173,5 [6.83]	217,0 [8.54]	32,5 [1.28]
HW... 250	176,0 [6.93]	219,5 [8.64]	34,8 [1.37]
HW... 300	182,5 [7.19]	226,0 [8.89]	41,4 [1.63]
HW... 315	184,5 [7.26]	228,0 [8.98]	43,5 [1.71]
HW... 350	189,0 [7.44]	232,5 [9.15]	48,0 [1.89]
HW... 370	192,0 [7.56]	235,5 [9.27]	51,0 [2.01]
HW... 400	196,0 [7.72]	239,5 [9.43]	54,8 [2.16]
HW... 470	206,0 [8.11]	249,5 [9.82]	65,0 [2.56]
HW... 500	210,5 [8.29]	254,0 [10.00]	69,4 [2.73]
HW... 535	215,0 [8.46]	258,8 [10.19]	74,1 [2.92]
HW... 550	217,0 [8.54]	260,5 [10.26]	76,0 [2.99]

▽ - Motor Mounting Surface

	Versions	
	2	4
P <sub>(A,B)</sub>	2xG½	2x7/8-14UNF, O-ring

**Note:** For N<sub>FR</sub> and N<sub>SR</sub> see pages 116 and 117.

**Standard Rotation**  
Viewed from Shaft End  
Port **A** Pressurized - **CW**  
Port **B** Pressurized - **CCW**

**Reverse Rotation**  
Viewed from Shaft End  
Port **A** Pressurized - **CCW**  
Port **B** Pressurized - **CW**



\* For LSV option the dimension L is 3 mm [1.18 in] greater.

**DIMENSIONS AND MOUNTING DATA**

**HWD Wheel Mount**

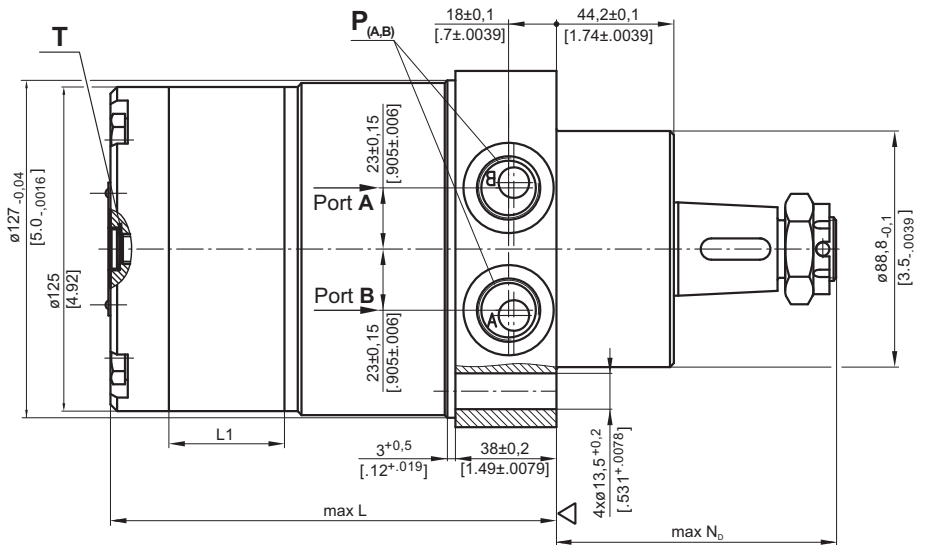
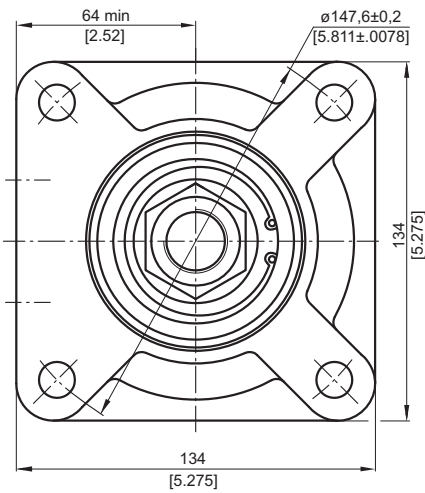

Versions		
	2	4
<b>P<sub>(A,B)</sub></b>	2xG <sup>1</sup> / <sub>2</sub>	2x <sup>7</sup> / <sub>8</sub> -14UNF, O-ring
<b>T</b>	G <sup>1</sup> / <sub>4</sub>	<sup>7</sup> / <sub>16</sub> -20UNF, O-ring

\* For LSV option the dimension L is 3 mm [0.118 in] greater.

Type	*L, mm [in]		L <sub>1</sub> , mm [in]
	HWD	HWV	
HW... 125	142,0 [5.59]	140,5 [5.53]	17,4 [0.68]
HW... 160	147,0 [5.79]	145,0 [5.71]	21,8 [0.86]
HW... 200	153,0 [6.02]	151,0 [5.94]	27,8 [1.09]
HW... 235	158,0 [6.22]	155,5 [6.12]	32,5 [1.28]
HW... 250	160,0 [6.30]	158,0 [6.22]	34,8 [1.37]
HW... 300	166,5 [6.56]	164,5 [6.46]	41,4 [1.63]
HW... 315	169,0 [6.65]	166,5 [6.56]	43,5 [1.71]
HW... 350	173,5 [6.83]	171,0 [6.73]	48,0 [1.89]
HW... 370	176,5 [6.95]	174,0 [6.85]	51,0 [2.01]
HW... 400	180,0 [7.09]	178,0 [7.01]	54,8 [2.16]
HW... 470	190,5 [7.50]	188,0 [7.40]	65,0 [2.56]
HW... 500	194,5 [7.66]	192,5 [7.58]	69,4 [2.73]
HW... 535	199,5 [7.85]	197,0 [7.76]	74,1 [2.92]
HW... 550	201,5 [7.93]	199,0 [7.83]	76,0 [2.99]

**Note:** For N<sub>b</sub> and N<sub>v</sub> see pages 116 and 117.

▽ - Motor Mounting Surface



**Standard Rotation**  
Viewed from Shaft End  
Port A Pressurized - **CW**  
Port B Pressurized - **CCW**

**Reverse Rotation**  
Viewed from Shaft End  
Port A Pressurized - **CCW**  
Port B Pressurized - **CW**

Versions		
	2	4
<b>T</b>	G <sup>1</sup> / <sub>4</sub>	<sup>7</sup> / <sub>16</sub> -20UNF, O-ring

**HWV Wheel Mount**

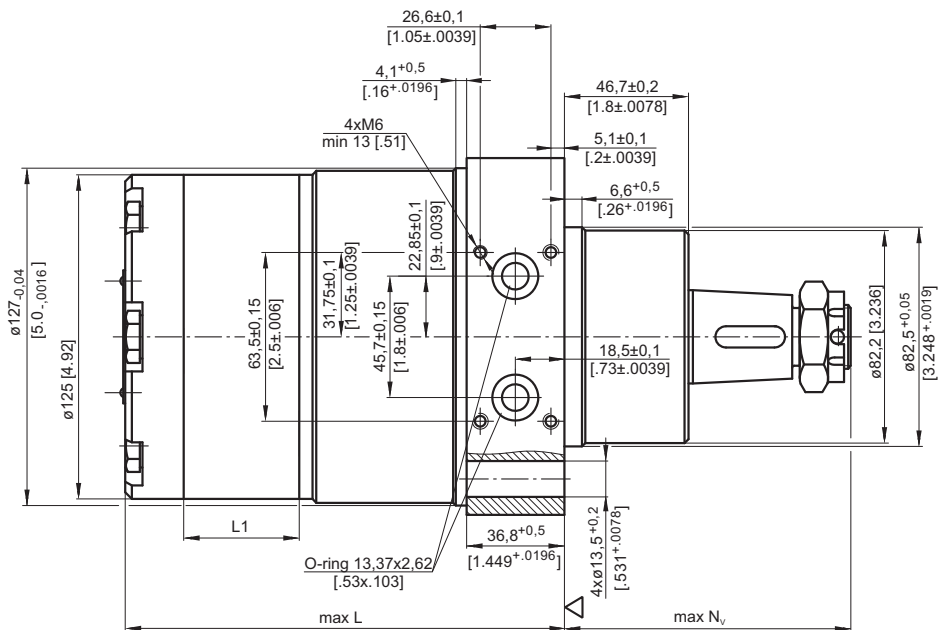
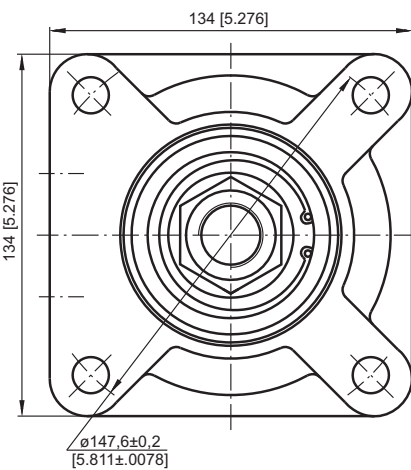

**DIMENSIONS AND MOUNTING DATA**

**HWF Magneto Mount**

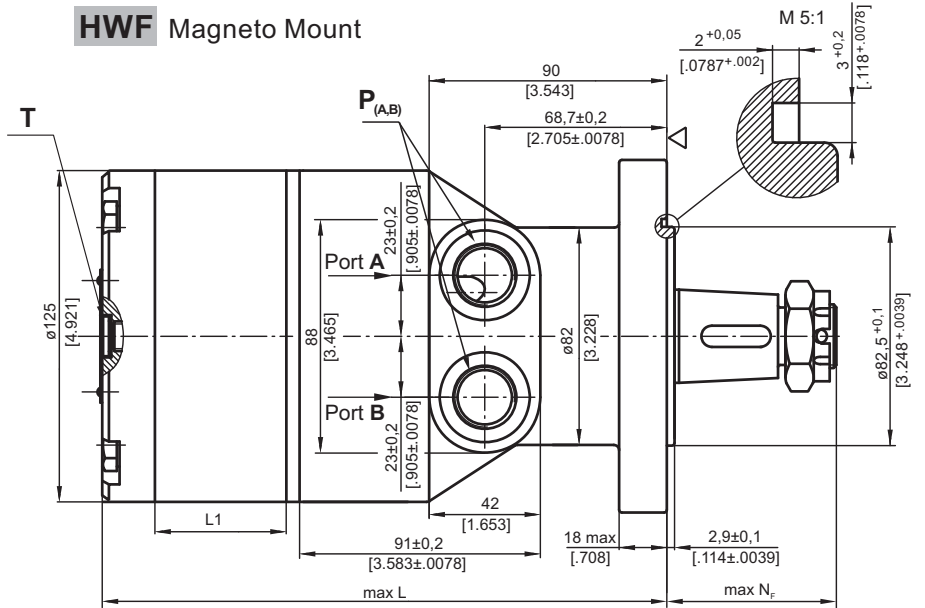
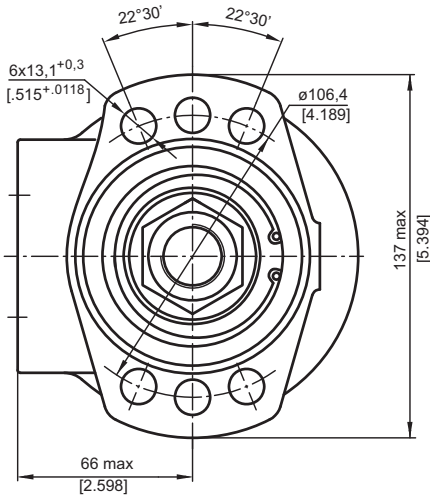

Type	*L, mm [in]	L <sub>1</sub> , mm [in]
HWF 125	184,0 [7.24]	17,4 [.68]
HWF 160	188,5 [7.42]	21,8 [.86]
HWF 200	194,5 [7.66]	27,8 [1.09]
HWF 235	199,0 [7.84]	32,5 [1.28]
HWF 250	201,5 [7.93]	34,8 [1.37]
HWF 300	208,0 [8.20]	41,4 [1.63]
HWF 315	210,0 [8.27]	43,5 [1.71]
HWF 350	214,5 [8.45]	48,0 [1.89]
HWF 370	217,5 [8.56]	51,0 [2.01]
HWF 400	221,5 [8.72]	54,8 [2.16]
HWF 470	231,5 [9.11]	65,0 [2.56]
HWF 500	236,0 [9.29]	69,4 [2.73]
HWF 535	240,5 [9.47]	74,1 [2.92]
HWF 550	242,5 [9.55]	76,0 [2.99]

	Versions	
	2	4
P <sub>(A,B)</sub>	2xG½	2x7/8-14UNF, O-ring
T	G ¼	7/16-20UNF, O-ring

Note: For N<sub>f</sub> see pages 116 and 117.

▽ - Motor Mounting Surface

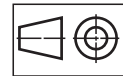

mm [in]

**Standard Rotation**  
Viewed from Shaft End  
Port A Pressurized - **CW**  
Port B Pressurized - **CCW**

**Reverse Rotation**  
Viewed from Shaft End  
Port A Pressurized - **CCW**  
Port B Pressurized - **CW**

\* For LSV option the dimension L is 3 mm [.118 in] greater.

**MAX. PERMISSIBLE SHAFT SEAL PRESSURE**

HW, HWF, HWS, HWD, HWV

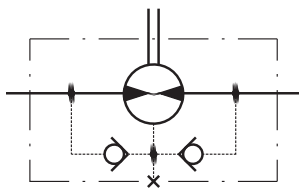

HWFR, HWSR

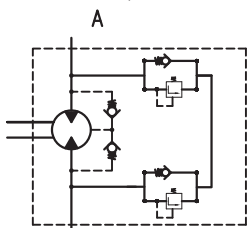

B

**HW... motors with drain connection:**

The shaft seal pressure equals the pressure in the drain line.

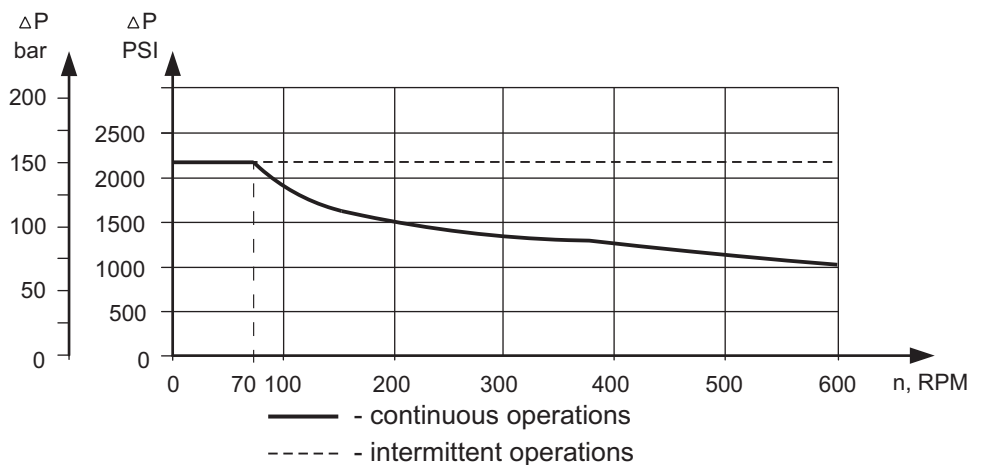

**PERMISSIBLE SHAFT LOADS**

**HW...**

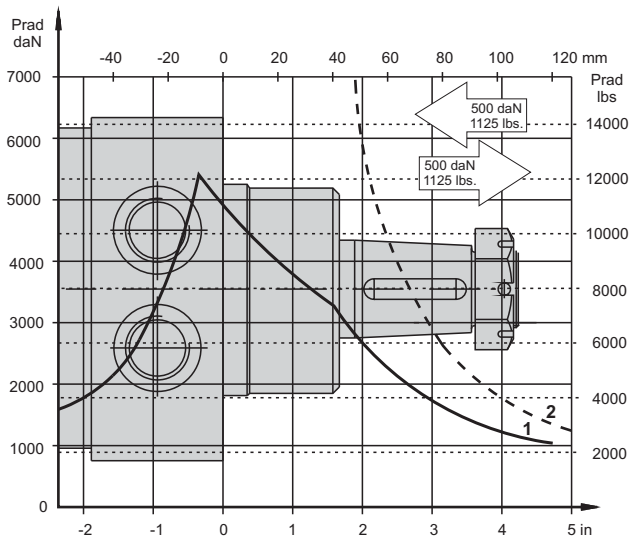

**HWF...**

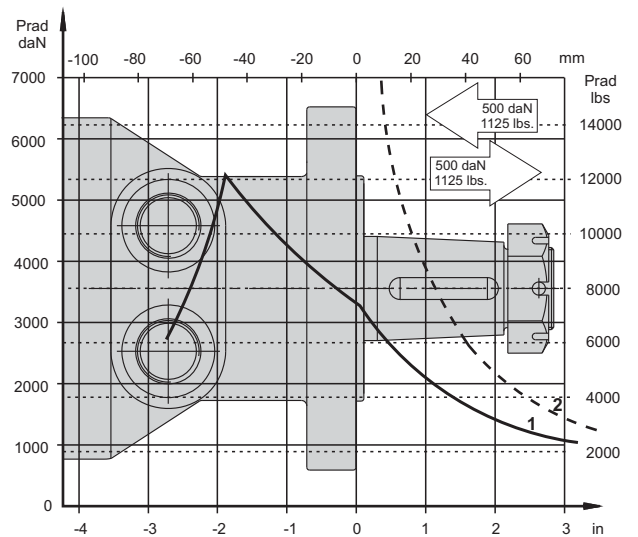

**HWV...**

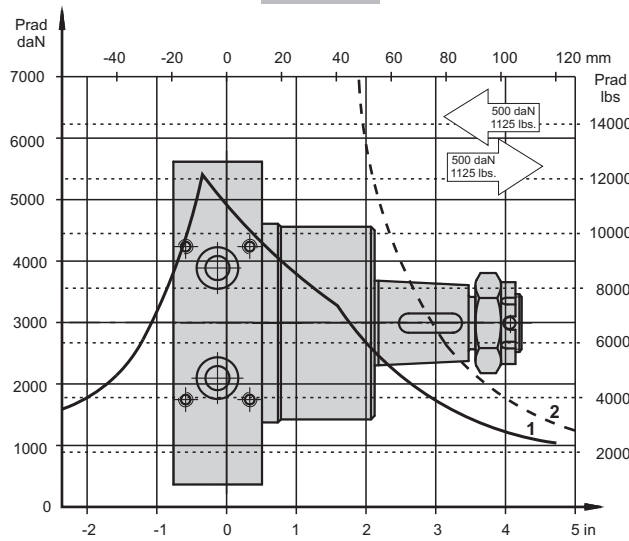

- 1 - Bearing curve: The curve applies to a B10 bearing life of 2000 hours at 100 RPM.
- 2 - Shaft curve: The curve represents Max. permissible radial shaft load with safety factor 3:1.

**SHAFT EXTENSIONS**

**C** - 1½"[38,1] straight, Parallel key 3/8"x3/8"x1½" BS46  
Max. Torque 120 daNm [10630 lb-in]

**CO** - ø25, straight, Parallel key A8x7x32 DIN 6885  
Max. Torque 40 daNm [3540 lb-in]

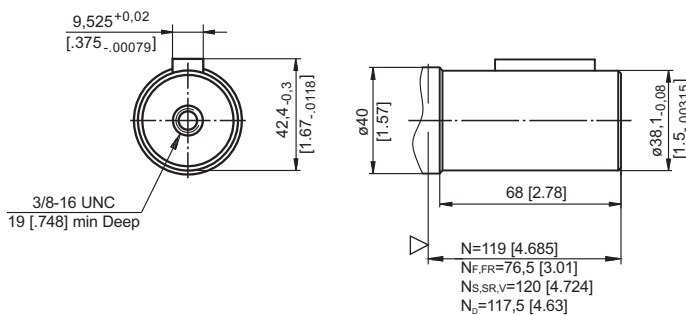

**W-W**

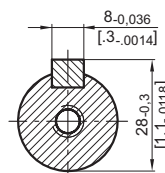

**W**

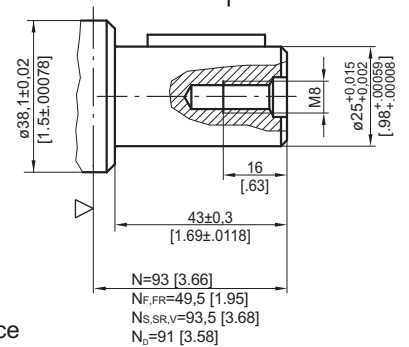

- N - for standard flange
- N<sub>F</sub> - for F flange
- N<sub>FR</sub> - for FR flange
- N<sub>S</sub> - for S flange
- N<sub>SR</sub> - for SR flange
- N<sub>D</sub> - for D flange
- N<sub>V</sub> - for V flange

▽ - Motor Mounting Surface



**W**

**K** - 1 1/4" straight, Parallel key 5/16"x5/16"x1 1/2" BS46  
Max. Torque 77 daNm [6815 lb-in]

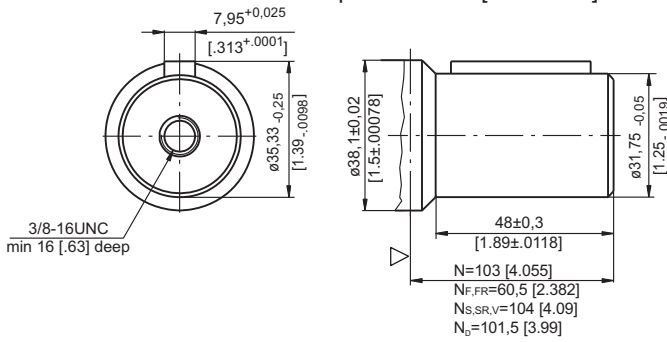

**M** - 32 straight, Parallel key A10x8x32 DIN 6885  
Max. Torque 77 daNm [6815 lb-in]

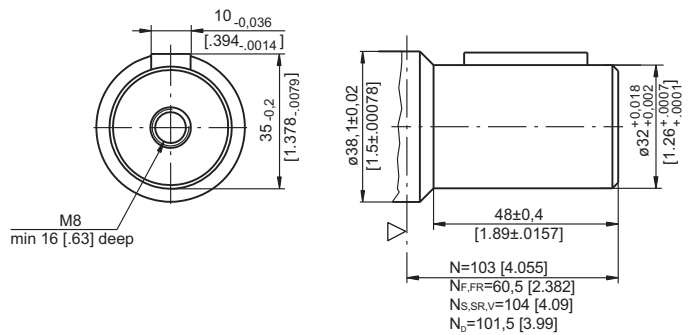

**L** - 1 1/4" splined 14T, DP12/24 ANSI B92.1-1976 Norm  
Max. Torque 95 daNm [8410 lb-in]

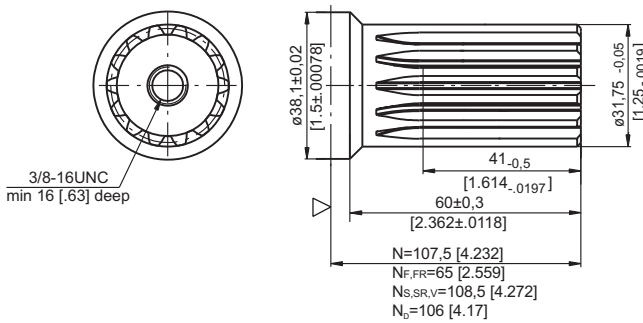

**KB** - 35 tapered 1:10, Parallel key 5/16"x5/16"x1 1/4" BS46  
Max. Torque 95 daNm [8410 lb-in]

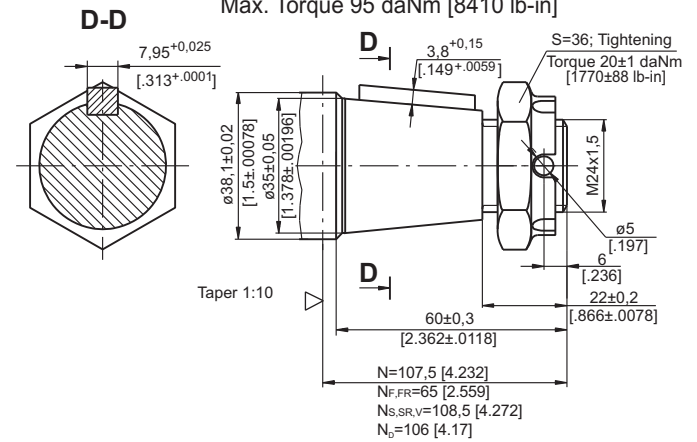

**T** - 1 1/2" tapered 1:8, Parallel key 5/16"x5/16"x1 1/4" BS46  
Max. Torque 120 daNm [10620 lb-in]

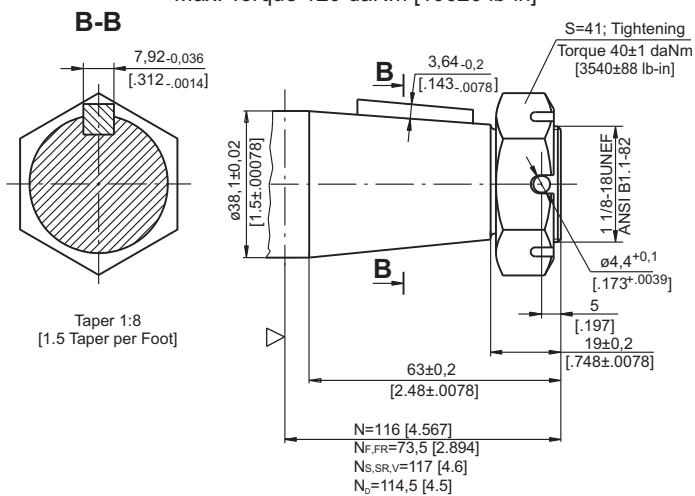

**R** - 1 1/4" tapered 1:8, Parallel key 5/16"x5/16"x1" BS46  
Max. Torque 77 daNm [6815 lb-in]

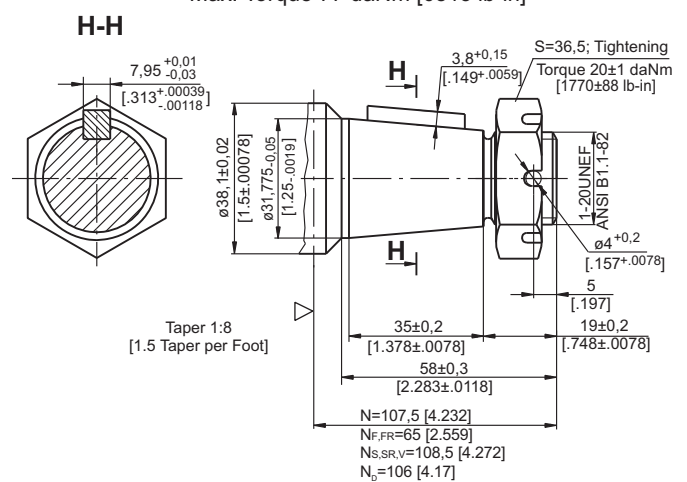

**SH** - 1" splined BS 2059, SAE 6B  
Max. Torque 40 daNm [3540 lb-in]



**E-E**

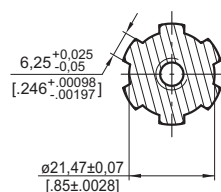

- N - for standard flange
- N<sub>F</sub> - for F flange
- N<sub>FR</sub> - for FR flange
- N<sub>S</sub> - for S flange
- N<sub>SR</sub> - for SR flange
- N<sub>D</sub> - for D flange
- N<sub>V</sub> - for V flange

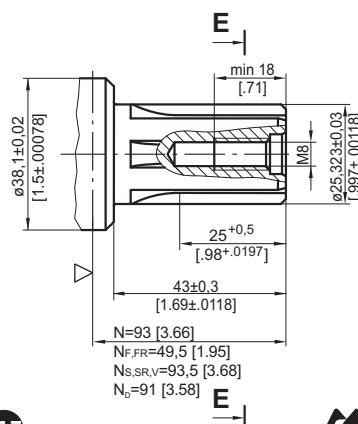

▽ - Motor Mounting Surface

**ORDER CODE**

	1	2	3	4	5	6	7
<b>HW</b>					/		

**Pos.1 - Mounting Flange**

- omit - Wheel mount, four holes
- F** - Oval mount, six holes
- FR** - Oval mount, six holes, relief valves
- S** - Wheel mount, four holes
- SR** - Wheel mount, four holes, relief valves
- D** - Wheel mount, four holes; mounting on  $\varnothing 88,8$  [3.5]
- V\*** - Wheel mount, four holes, valves

**Pos.2 - Displacement code**

- 125** - 126,0 cm<sup>3</sup>/rev [ 7.69 in<sup>3</sup>/rev]
- 160** - 158,0 cm<sup>3</sup>/rev [ 9.64 in<sup>3</sup>/rev]
- 200** - 201,3 cm<sup>3</sup>/rev [12.28 in<sup>3</sup>/rev]
- 235** - 235,0 cm<sup>3</sup>/rev [14.33 in<sup>3</sup>/rev]
- 250** - 252,0 cm<sup>3</sup>/rev [15.37 in<sup>3</sup>/rev]
- 300** - 300,0 cm<sup>3</sup>/rev [18.30 in<sup>3</sup>/rev]
- 315** - 314,9 cm<sup>3</sup>/rev [19.21 in<sup>3</sup>/rev]
- 350** - 347,8 cm<sup>3</sup>/rev [21.21 in<sup>3</sup>/rev]
- 370** - 369,0 cm<sup>3</sup>/rev [22.51 in<sup>3</sup>/rev]
- 400** - 396,8 cm<sup>3</sup>/rev [24.20 in<sup>3</sup>/rev]
- 470** - 470,6 cm<sup>3</sup>/rev [28.71 in<sup>3</sup>/rev]
- 500** - 502,4 cm<sup>3</sup>/rev [30.65 in<sup>3</sup>/rev]
- 535** - 536,0 cm<sup>3</sup>/rev [32.70 in<sup>3</sup>/rev]
- 550** - 550,0 cm<sup>3</sup>/rev [33.55 in<sup>3</sup>/rev]

**Pos.3 - Shaft Extensions\*\***

- K** - 1 1/4" [31,75] straight, Parallel key  $\frac{5}{16}$ "x $\frac{5}{16}$ "x1 1/2" BS46
- KB** -  $\varnothing 35$  tapered 1:10, Parallel key  $\frac{5}{16}$ "x $\frac{5}{16}$ "x1 1/4" BS46
- L** - 1 1/4" [31,75] splined 14T, ANSI B92.1-1976
- M** -  $\varnothing 32$  straight, Parallel key A10x8x32 DIN 6885
- R** - 1 1/4" [31,75] Tapered 1:8, Parallel key  $\frac{5}{16}$ "x $\frac{5}{16}$ "x1 1/4" BS46
- T** - 1 1/2" [38,1] Tapered 1:8, Parallel key  $\frac{5}{16}$ "x $\frac{5}{16}$ "x1 1/4" BS46
- C** - 1.57" [40] straight, Parallel key  $\frac{3}{8}$ "x $\frac{3}{8}$ "x1 1/2" BS46
- CO** -  $\varnothing 25$ , straight, Parallel key A8x7x32 DIN 6885
- SH** -  $\varnothing 1$ " splined BS 2059, SAE 6B

**Pos.4 - Ports**

- 2** - side ports, 2xG1/2, G1/4, BSP thread, ISO 228
- 4** - side ports, 2x7/8-14 UNF, O-ring, 7/16-20 UNF

**Pos.5 - Special Features\*\*\* [see page 119]**

**Pos.6 - Valves Pressure Range, bar\*\*\*\***

- /** - 70, 100, 140, 170, 210

**Pos.7 - Design Series**

- omit - Factory specified

**NOTES:**

- \* Flange **V** is for versions 2 and 4 - drainage only!
- \*\* The permissible output torque for shafts must not be exceeded!
- \*\*\* If the code on pos.5 is not specified in the order, it will be considered as LL-option.
- \*\*\*\* For **SR** and **FR** only!

The hydraulic motors are manganophosphatized as standard.

# MOTOR SPECIAL FEATURES

Special Feature Description	Order Code	Motor type														
		MM	MP	MPW	MP(W)N	MR	MRN	MRB	SP, SR	PL	RL	PK(Q)	RK	RW	MH	HW
Speed Sensor*	RS	O	O	-	-	O	-	-	-	-	-	-	-	-	O	-
Tacho connection	T	-	-	-	-	O	O	-	-	-	-	-	-	-	O	-
Low Leakage	LL	O	-	-	-	O	O	-	-	-	O	-	O	O	O	O
Low Speed Valving	LSV	-	-	-	-	O	-	-	-	-	-	-	-	-	O	O
Free Running	FR	O	O	O	O	O	O	-	-	O	O	O	O	O	O	-
Reverse Rotation	R	O	O	O	O	O	O	O	O	O	O	O	O	O	O	O
Paint**	P	O	O	O	O	O	O	O	O	O	O	O	O	O	O	O
Corrosion Protected Paint**	PC	O	O	O	O	O	O	O	O	O	O	O	O	O	O	O
Special Paint***	PS	O	O	O	O	O	O	O	-	O	O	O	O	O	O	O
	PCS	O	O	O	O	O	O	O	O	O	O	O	O	O	O	O
Check Valves		S	S****	S****	S	S****	S	S	S	S	S	S	S	S****	S****	S

<b>O</b>	Optional
<b>-</b>	Not applicable
<b>S</b>	Standard

\* For sensor ordering see pages 120÷121.

\*\* Colour at customer's request.

\*\*\* Non painted feeding surfaces, colour at customer's request.

\*\*\*\* Without check valves for "U" shaft seal versions.

# MOTORS WITH SPEED SENSOR

## MM...RS

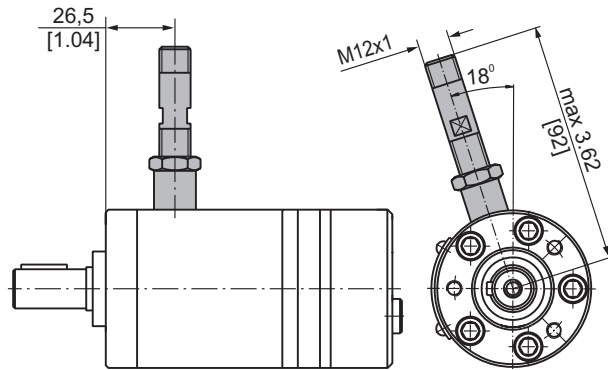

## MP...RS and MR...RS

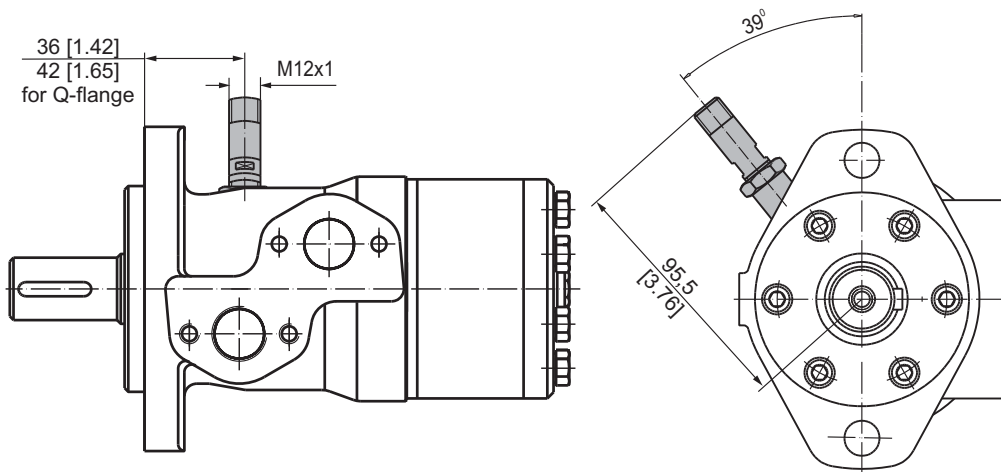

## MH...RS

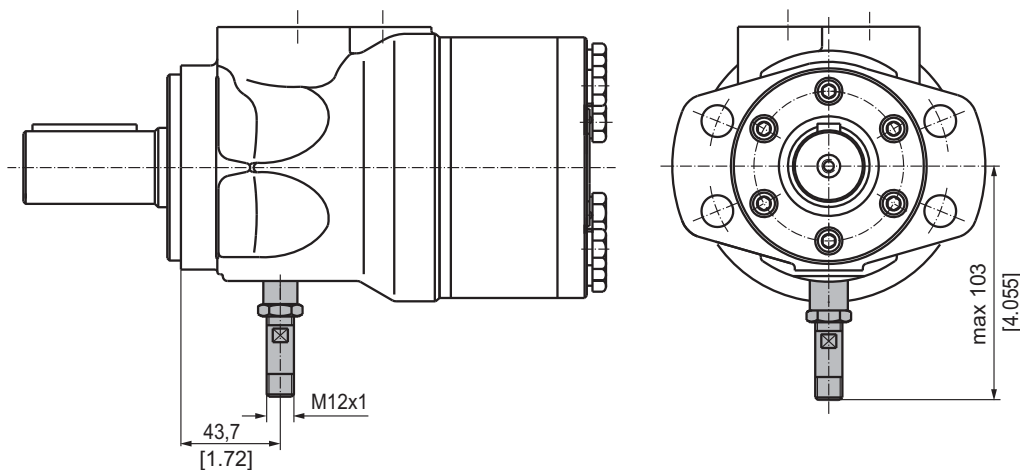

**TECHNICAL DATA OF THE SPEED SENSOR**

**Technical data**

Frequency range	0...15 000 Hz
Output	PNP, NPN
Power supply	10...36 VDC
Current input	20 mA (@24 VDC)
Ambient Temperature	-40...+125°C [-40...+257°F]
Protection	IP 67
Plug connector	M12-Series
Mounting principle	ISO 6149

**Output signal**

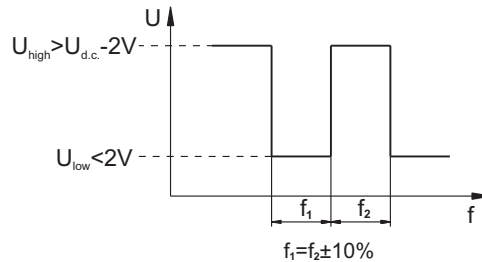

Load max.:  $I_{high} = I_{low} < 50\text{mA}$

Motor type	MM	MP	MR	MH
Pulses per revolution	30	36	36	42

**Wiring diagrams**

**PNP**

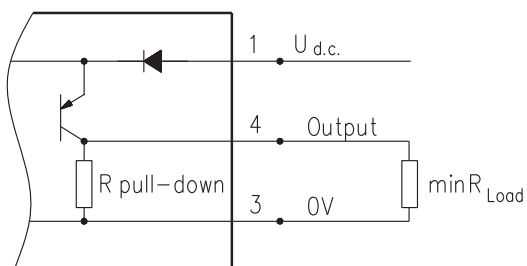

**NPN**

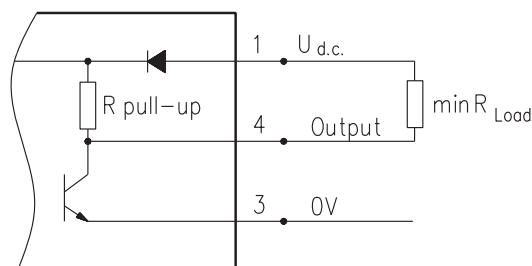

$$R_{Load} [\text{k}\Omega] = U_{d.c.} [\text{V}] / I_{max} [\text{mA}]$$

**Stick type**

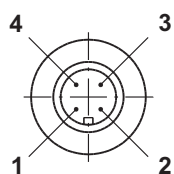

Terminal No.	Connection	Cable Output
1	$U_{d.c.}$	Brown
2	No connection	White
3	0V	Blue
4	Output signal	Black

**Order Code for Speed Sensor**

Sensor Code	Output type	Electric connection
<b>RSN</b>	NPN	Connector BINDER 713 series
<b>RSP</b>	PNP	Connector BINDER 713 series
<b>RSNL5</b>	NPN	Cable output 3x0,25; 5 m [196 in] long
<b>RSPL5</b>	PNP	Cable output 3x0,25; 5 m [196 in] long

**NOTE:** \*- The speed sensor is not fitted at the factory, but is supplied in a plastic bag with the motor. For installation see enclosed instructions.

# APPLICATION CALCULATION

## VEHICLE DRIVE CALCULATIONS

### 1. Motor speed: n, RPM

$$n = \frac{2,65 \times v_{km} \times i}{R_m} \quad n = \frac{168 \times v_{mi} \times i}{R_{in}}$$

$v_{km}$ - vehicle speed, km/h;

$v_{mi}$ - vehicle speed, mil/h;

$R_m$ - wheel rolling radius, m;

$R_{in}$ - wheel rolling radius, in;

$i$ - gear ratio between motor and wheels.

If no gearbox, use  $i=1$ .

### 2. Rolling resistance: RR, daN [lbs]

The resistance force resulted in wheels contact with different surfaces:

$$RR = G \times \rho$$

$G$ - total weight loaded on vehicle, daN [lbs];

$\rho$ - rolling resistance coefficient (Table 1).

Table 1

Rolling resistance coefficient In case of rubber tire rolling on different surfaces	
Surface	$\rho$
Concrete- faultless	0.010
Concrete- good	0.015
Concrete- bad	0.020
Asphalt- faultless	0.012
Asphalt- good	0.017
Asphalt- bad	0.022
Macadam- faultless	0.015
Macadam- good	0.022
Macadam- bad	0.037
Snow- 5 cm	0.025
Snow- 10 cm	0.037
Polluted covering- smooth	0.025
Polluted covering- sandy	0.040
Mud	0.037÷0.150
Sand- Gravel	0.060÷0.150
Sand- loose	0.160÷0.300

### 3. Grade resistance: GR, daN [lbs]

$$GR = G \times (\sin \alpha + \rho \times \cos \alpha)$$

$\alpha$ - gradient negotiation angle (Table 2)

Table 2

Grade %	$\alpha$ Degrees	Grade %	$\alpha$ Degrees
1%	0° 35'	12%	6° 5'
2%	1° 9'	15%	8° 31'
5%	2° 51'	20%	11° 19'
6%	3° 26'	25%	14° 3'
8%	4° 35'	32%	18°
10%	5° 43'	60%	31°

### 4. Acceleration force: FA, daN [lbs]

Force  $FA$  necessary for acceleration from 0 to maximum speed  $v$  and time  $t$  can be calculated with a formula:

$$FA = \frac{v_{km} \times G}{3,6 \times t}, [daN] \quad FA = \frac{v_{mi} \times G}{22 \times t}, [lbs];$$

$FA$ - acceleration force, daN [lbs];

$t$ - time, [s].

### 5. Tractive effort: DP, daN [lbs]

Tractive effort  $DP$  is the additional force of trailer. This value will be established as follows:

-acc.to constructor's assessment;

-as calculating forces in items 2, 3 and 4 of trailer; the calculated sum corresponds to the tractive effort requested.

### 6. Total tractive effort: TE, daN [lbs]

Total tractive effort  $TE$  is total effort necessary for vehicle motion; that the sum of forces calculated in items from 2 to 5 and increased with 10 % because of air resistance.

$$TE = 1,1 \times (RR + GR + FA + DP)$$

$RR$ - force acquired to overcome the rolling resistance;

$GR$ - force acquired to slope upwards;

$FA$ - force acquired to accelerate (acceleration force);

$DP$ - additional tractive effort (trailer).

### 7. Motor Torque moment: M, daNm [in-lb]

Necessary torque moment for every hydraulic motor:

$$M = \frac{TE \times R_{in} [R_m]}{N \times i \times \eta_m}$$

$N$ - motor numbers;

$\eta_m$ - mechanical gear efficiency (if it is available).

### 8. Cohesion between tire and road covering: $M_w$ , daNm [in-lb]

$$M_w = \frac{G_w \times f \times R_{in} [R_m]}{i \times \eta_m}$$

To avoid wheel slipping, the following condition should be observed  $M_w > M$

$f$  - frictional factor;

$G_w$ - total weight over the wheels, daN [lbs].

Table 3

Surface	Frictional factor $f$
Steel on steel	0.15 ÷ 0.20
Rubber tire on polluted surface	0.5 ÷ 0.7
Rubber tire on asphalt	0.8 ÷ 1.0
Rubber tire on concrete	0.8 ÷ 1.0
Rubber tire on grass	0.4

**9.Radial motor loading:  $P_{rad}$ , daN [lbs]**

When motor is used for vehicle motion with wheels mounted directly on motor shaft, the total radial loading of motor shaft  $P_{rad}$  is a sum of motion force and weight force acting on one wheel.

- $G_w$  - Weight held by wheel;
- $P_{rad}$  - Total radial loading of motor shaft;
- $M/R$  - Motion force.

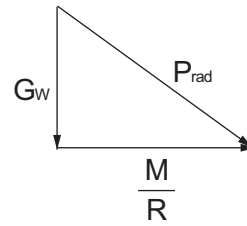

$$P_{rad} = \sqrt{G_w^2 + \left(\frac{M}{R}\right)^2}$$

In accordance with calculated loadings the suitable motor from the catalogue is selected.

**DRAINAGE SPACE AND DRAINAGE PRESSURE**

Advantages in oil drainage from drain space: Cleaning; Cooling and Seal lifetime prolonging.

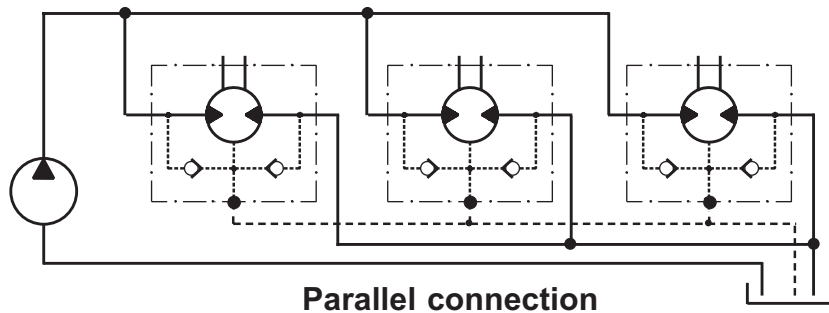
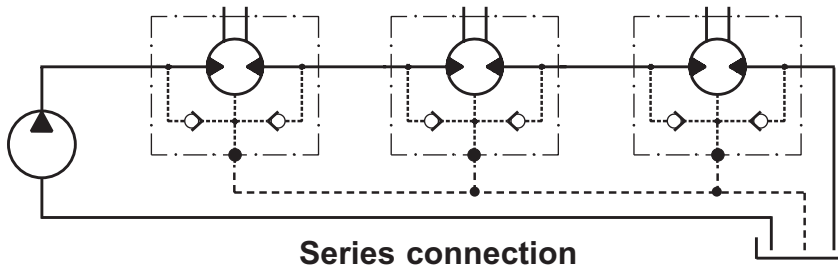

# WARRANTY

M+S Hydraulic warrants, that its products, supplied directly to original equipment manufacturer, authorized distributor or other customer, will be free of defects in material or workmanship at the time of shipment from M+S Hydraulic and will conform to the products technical documentation (drawings and specifications) under sale agreement with Buyer.

This warranty will apply only to defects appearing within applicable Warranty period, mentioned below. If Buyer notifies M+S Hydraulic within the Warranty period about any such defects, M+S, at its sole option will replace or repair the defective products or their parts found by M+S Hydraulic to be defective in material or workmanship.

THE FOREGOING LIMITED WARRANTY IS AVAILABLE ONLY IF "M+S HYDRAULIC" IS PROMPTLY NOTIFIED IN WRITTEN OF THE ALLEGED DEFECT AND DOES NOT COVER FAILURE TO FUNCTION CAUSED BY DAMAGE TO THE PRODUCT, IMPROPER INSTALLATION, UNREASONABLE USE OR ABUSE OF THE PRODUCT, FAILURE TO PROVIDE OR USE OF IMPROPER MAINTENANCE OR USUAL, DEGRADATION OF THE PRODUCT DUE TO PHYSICAL ENVIRONMENTS OF AN USUAL NATURE. THE FOREGOING REMEDIES ARE THE SOLE AND EXCLUSIVE REMEDIES AVAILABLE TO CUSTOMER. To facilitate the inspection, M+S Hydraulic may require return of the product/part, which Buyer claims to be defective.

M+S Hydraulic shall not be liable for labor costs or any other expenses incurred during the disassembling or reinstalling of the product/part.

In case the claimed products are returned to M+S Hydraulic in bad condition: dirty, disassembled, with damaged or missing parts during transportation, the warranty will be considered as not applicable and the products will not be liable to repair.

## Warranty periods

**New products:** The Warranty period is limited to 24 consecutive months (2 years) from the date of production of the product.

**Repaired products:** If the product is repaired in M+S Hydraulic during its warranty period, the warranty period of the repaired item shall continue for the balance of original Warranty period or for a period equal to 50% of the original new product Warranty period, whichever is later.

**Spare parts:** The Warranty period for Spare parts is 12 consecutive months (1 year) from the dispatch date of such parts from M+S Hydraulic.

**LIMITATION OF LIABILITY** M+S Hydraulic's liability for claim of any kind, for loss or damage arising out of, connected with or resulting from an order, or from the performance or branch thereof, or from the design, manufacture, sale delivery, operation or use of any of its products shall be limited to, at M+S 's sole option, replacement, repair of any defective product or the issuance of a credit to Customer against any future purchases. Cash refunds will not be made under any circumstances and Customer will not be entitled to recover any damages of any kind against M+S Hydraulic, including but not limited to incidental or consequential damages, whether direct or indirect, known or unknown, foreseen or unforeseen.



**M+S HYDRAULIC**

68, Kozloduy St., 6100 Kazanlak, Bulgaria

Tel.: ++359 431 65167

++359 431 64271

Fax: +359 431 64114

E-Mail: [msh@ms-hydraulic.com](mailto:msh@ms-hydraulic.com)

URL: <http://www.ms-hydraulic.com>