

Read this manual before operation

- The content include of electric connections and operating steps
- Read the manual to operate the systems

RDC8445S

Laser Cutting Controller User Manual V1.0

RuiDa Technology Co., Ltd

Addr: 202-203,B-Block,Technology Building, 1057 Nanhai Avenue,
Nanshan District, SHENZHEN, CHINA

Tel: 0755--26066687

Fax: 0755--26982287

E-mail: sales@rd-ac.com

Web: www.rd-ac.com

COPYRIGHT

Shenzhen Reader Technology Co., Ltd. reserves all rights.

Shenzhen Reader Technology Co., Ltd. (hereinafter referred to as “RD Co., Ltd.”) holds the patent right, copyright and other intellectual property rights for this product and its related software. Without authorization, no one is allowed to copy, manufacture, process and use this product and its relative parts directly or indirectly.

RD Co., Ltd. is entitled to increase or reduce and modify the shape and functions of this product stated herein as well as amend any documents attached to this product, without prior notification.

The users should peruse this Manual prior to using the product stated herein. RD Co., Ltd. shall not be responsible for the direct, indirect, special, incidental or corresponding losses or damages arising out of improper use hereof or of this product.

The machine in operation is dangerous, so the users are obliged to design and institute the effective mechanism for error handling and safety protection. RD Co., Ltd. shall not undertake any duties or responsibilities for the incidental or corresponding losses arising therefrom.



CERTIFICATION DECLARATION



CE

The product has been certified by the CE (Communate European) safety certification. It has passed the corresponding conformity assessment procedure and the manufacturer's declaration of conformity, in accordance with the relevant EU directive.



ROHS

This product has been certified by EU legislation (Restriction of Hazardous Substances) Safety certification; comply with relevant EU environmental regulations.



FCC

This product has been certified by the Federal Communications Commission for safety, Comply with us electronic safety regulations.

SAFETY INFORMATION

When using this system, please make sure the operation is correct and the usage is safe. Some signs or text will be used to remind you to pay attention to the dangerous matters and some important information.



Dangerous:

Indicates a serious danger. In the process of use, if the operation is improper or the way of use is wrong, it may cause serious injury or even death to the user. Please do not operate it easily until you have made sure that the operation method is correct and the way of use is correct.



Warning:

Danger. In the process of use, if the operation is improper or the use is wrong, which may lead to the injury of the personnel, please do not operate the personnel and related personnel easily, until ensure the correct operation method and use method is correct before use.



Cautious:

Represents the potential risk of the product. In the process of use, if the use method is wrong or improper operation, it may cause damage to the product or some parts. Please do not use it until you have made sure that the operation method is correct and the usage is correct.

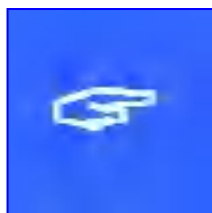

Important:

Represents important information to be paid attention to during the use of the product. Please do not ignore this information, this information will provide effective operational help.



This sign indicates laser radiation, which is usually posted on products with laser output. Please be careful with laser and pay attention to safety when using this kind of equipment.

Sign in、 Devanning、 Examine cargo

The product itself with plastic or metal shell, can protect the external electrical components from damage. The products are packed in foam bags and anti-static bags. If there is any external damage to the package, check the equipment and notify the carrier and carrier in writing of the damage.

Important:



After receiving the product, please check whether the outer package is intact, check whether the product is complete after unpacking and whether all parts are intact. If any damage is found, please contact ruida immediately.

Remove all cargo from package and keep packing material and wiring parts. Please take care of the safety of the goods when unpacking them. After taking out the goods, please check whether the parts are complete and intact. If any missing parts or damaged parts are found, please contact ruida technology immediately. Do not install or debug the equipment if any obvious damage is found.

Contents

Section 1 Overview	1
1.1 BRIEF INTRODUCTION	2
1.2 CONTROLLER MODEL DESCRIPTION	2
1.3 CONTROLLER PERFORMANCE COMPARISON	2
Section 2 Installation dimensions	6
2.1 MAINBOARD MOUNTING DIMENSIONS	7
2.2 PANEL MOUNTING DIMENSIONS	7
ALL SIZES ARE IN MM AND ACCURATE TO 0.1MM	7
3.1 PHYSICAL DRAWING OF THE MAINBOARD	9
3.2 PANEL PHYSICAL IMAGE	9
3.3 DIAGRAM OF THE ELECTRICAL CONNECTION OF THE CONTROL SYSTEM	10
Section 4 Description of the mainboard interface signal	11
4.1 AAIN POWER INTERFACE CN0	12
4.2 PANEL SIGNAL-CABLE INTERFACE HMI	12
4.3 UDISK INTERFACE	12
4.4 PC-USB INTERFACE	12
4.5 ETHERNET INTERFACE	12
4.6 GENERAL/DEDICATED OUTPUT INTERFACE CN1	13
4.7 GENERAL/DEDICATED INPUT INTERFACE CN2	13
4.8 FOUR-AXIS LIMIT INPUT INTERFACE CN3/CN4	14
4.9 X/Y/Z/U FOUR-AXIS DRIVE INTERFACE AXIS_X~AXIS_U	15
4.10 LASER POWER CONTROL INTERFACE CN5/CN6	16
Section 5 Example of a laser power interface	18
5.1 OVERVIEW	19
5.2 SCHEMATIC DIAGRAM OF LASER POWER SUPPLY WIRING FOR GLASS TUBE	20
5.3 SCHEMATIC DIAGRAM OF RF CO2 LASER WIRING	21
Section 6 Stepper motor driver interface	22
6.1 OVERVIEW	23
6.2 SCHEMATIC DIAGRAM OF THE DRIVE WIRING	24
Section 7 IO Port Wiring	25
7.1 INPUT PORT	26
7.2 OUTPUT	27
Section 8 HMI operation	28
8.1 BRIEF INTRODUCTION	29
8.1.1 Overview	29
8.1.2 Key Functions	30
8.1 MAIN INTERFACE FEATURES	31
8.2 POWER SETTINGS	33
8.3 LAYER FUNCTION	34
8.4 MENU FUNCTION	35
8.4.1 User parameters	36



8.4.2 Manufacture parameters	39
8.4.3 Positioning settings	40
8.4.4 Controller settings	41
8.4.5 Function	52
8.4.6 Back up factory parameters	59
8.4.7 Restore factory parameters	59
8.4.8 Permissions management	59
8.5 FILE MANAGEMENT	61
8.5.1 Memory files	61
8.5.2 Memory operations	62
8.5.3 USB flash drive file	63
8.6 PASSWORD ENTRY AND SETTINGS	64
8.6.1 Password entry	64
8.6.2 Password settings	65
8.7 PROMPT AND ALARM INFORMATION	65
Section 9 Auto Focus	67
9.1 AUTO FOCUS	68
Section 10 Manufacturer/User Parameters Introduction	69
10.1 MANUFACTURER PARAMETERS	70
10.2 USER PARAMETERS	74
Section 11 Communication	79
11.1 OVERVIEW	80
11.2 USB COMMUNICATION	80
11.2.1 USB Driver installation	80
11.2.2 USB communication with software	83
11.3 WIRED NETWORK COMMUNICATION <ETHERNET CABLE>	84
11.3.1 Communication with RDWorksV8 over a wired network	84
11.3.2 The software is used via a wired network connection to the WEB	86
11.3.3 Communicate with the mobile app over wired network	87
11.4 WIFI	87
11.4.1 Communicates with RDWorksV8 via WIFI	87
11.4.2 Connect to the web via Wi-Fi and use the software	88
11.4.3 Communicate with APP via WIFI	89
11.5 A SUMMARY OF COMMON CONNECTION METHODS	89
11.5.1 WEB	89
11.5.2 Required WEB Application Software Functions	90
11.6 PRECAUTIONS	91
Section 12 Instructions for mobile APP	92
12.1 LIST OF DEVICES	94
12.2 CREATION OF PROCESSING FILES	101
12.3 FILE MODULE	125
12.4 EQUIPMENT DEBUGGING AND EQUIPMENT PARAMETERS	134
12.4.1 Equipment debugging	134
12.4.2 Device parameters	138



12.5 FIRMWARE UPGRADES	140
12.6 USER MODULE	143
12.6 OTHER FEATURES	148
Section 13 Mantisurf User Guide	152
13.1 MANTISURF INTRODUCE	153
13.2 MAINBOARD CONNECTION	153
13.2.1 The mainboard is connected to a WiFi hotspot	153
13.2.2 ENABLE WEB USAGE	154
13.3 USER MODULE	154
13.3.1 User Registration	154
13.3.2 The user retrieves the password	156
13.3.3 User login	157
13.3.4 Account settings	158
13.3.5 Language switching	158
13.4 EQUIPMENT ADDITION AND BLUEPRINT GENERATION	159
13.4.1 Equipment addition	159
13.4.2 Create a new blank page	160
13.4.3 Import the design	161
13.5 DRAWING OPERATIONS	162
13.6 THE MENU BAR ON THE LEFT IS INTRODUCED	175
13.6.1 Home	175
13.6.2 Processing History	179
13.6.3 Draft box	179
13.6.4 Recycle Bin	180
13.6.5 Resource Community	180

Section 1 Overview

CONTENTS:

- Briefing introduction
- Controller model description
- Controller performance comparison

1.1 Brief introduction

The RDC8445S system is the latest generation laser engraving/cutting control system developed by Ruida Technology. This control system offers enhanced hardware stability and superior resistance to high voltage and static interference. Its 5-inch color screen human-machine interface provides a more user-friendly operation interface and more powerful functions.

The controller features improved and robust motion control capabilities, a large-capacity file storage system, and dual independently adjustable laser power control interfaces with enhanced compatibility. It also supports a more versatile USB drive, multiple general-purpose/specialized IO controls, and PC communication via Ethernet, USB, and optional Wi-Fi connections.

Additionally, it supports an all-new mobile app and web-based application software for a seamless and modern user experience.

1.2 Controller model description

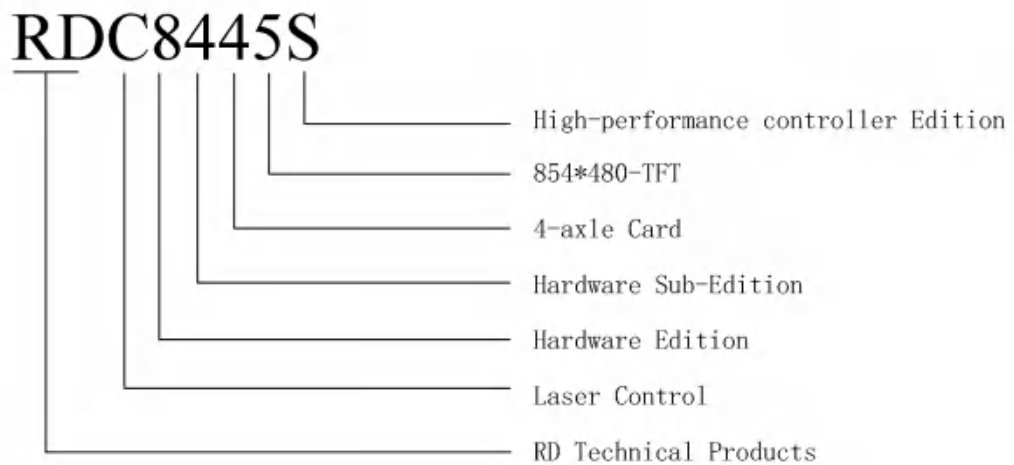

1.3 Controller performance comparison

Table 1-1 Controller performance comparison table

		RDC6445G	RDC8445S
Power supply		Single-channel 4V	Single-channel 24V
Laser port		Two digital laser	Two digital laser interfaces,

		<i>interfaces, which can be set independently, have strong compatibility</i>	<i>which can be set independently, it has strong compatibility</i>
USB flash drive	Copy speed	<i>slow</i>	<i>Fast, triple higher</i>
	compatibility	<i>Support more brands of U disks</i>	<i>Support all capacities and all brands of USB flash drives</i>
Memory	capacity	<i>128M</i>	<i>1G</i>
	Fault tolerance	<i>It can self-test bad sectors, can be formatted, and has good fault tolerance</i>	<i>It can self-test bad sectors, can be formatted, and has good fault tolerance</i>
General I/O features	Input port	<i>4 ways (two for general, two for specialties)</i>	<i>4 ways (two for general, two for specialties)</i>
	Output	<i>4 channels (drive capacity 500mA, OC output, freewheeling protection.)</i>	<i>4 channels (drive capacity 500mA, OC output, freewheeling protection)</i>
Software features	Power Failure Resume	<i>YES</i>	<i>YES</i>
	Multi-Point Positioning Logic	<i>YES</i>	<i>YES</i>
	Parameter backup logic	<i>YES</i>	<i>YES</i>
	Time Estimation Preview	<i>YES(The preview value is the same as the actual work time, accurate to the millisecond)</i>	<i>YES (The preview value is consistent with the actual work time, accurate to the millisecond)</i>
	Upgrade the mainboard program online	<i>YES</i>	<i>YES</i>
Display	Online Modification	<i>YES</i>	<i>YES</i>

features	Laser Power/Speed		
	Modify layer parameters offline	<i>YES</i>	<i>YES</i>
	Upgrade the boot screen	<i>NO</i>	<i>NO</i>
	Graphic dynamic/static preview	<i>YES</i>	<i>YES</i>
	The processing progress bar is displayed	<i>YES</i>	<i>YES</i>
	Modify vendor/user parameters	<i>NO</i>	<i>YES</i>
	Display type	<i>Color 320*480TFT</i>	<i>Color 320*480TFT</i>
Axis features	Soft limits	<i>YES</i>	<i>YES</i>
	Hard limits	<i>YES</i>	<i>YES</i>
	Z-axis linkage	<i>YES</i>	<i>YES</i>
	Feeding axis	<i>Single/bi-directional optional</i>	<i>Single/bi-directional optional</i>
	Startup Homing	<i>Configurable</i>	<i>Configurable</i>
	The speed of the buttons	<i>Configurable</i>	<i>Configurable</i>
	Number of axes	<i>4</i>	<i>4</i>
Encryption features		<i>There is no independent time system, which can be encrypted</i>	<i>There is no independent time system, which can be encrypted</i>
Communication mode		<i>10/100M Ethernet + USB2.0, mainboard automatically detects communication mode</i>	<i>10/100M Ethernet + USB2.0, mainboard automatically detects communication mode</i>
Wifi communication		<i>NO</i>	<i>YES</i>



WEB Use software		<i>NO</i>	<i>YES, Support multi-platform operating systems <Windows, macOS, Linux></i>
Mobile app		<i>Only simple controls such as moving,frame, etc. are supported</i>	<i>It supports multi-device connection control, supports reading and writing of all parameters, supports APP to directly control the operating equipment, supports upgrading the motherboard program in APP, supports editing graphics in APP, supports direct photo processing in APP, supports import file processing in APP, and supports exporting processing files in APP. < all mobile phone operating systems: Android, Apple, HarmonyOS and other ></i>

Section 2 Installation dimensions

CONTENTS:

- Mainboard mounting dimensions
- Panel mounting dimensions

2.1 Mainboard mounting dimensions

All dimensions are in mm and accurate to 0.1mm (with four positioning holes in symmetrical positions)



Fig.2-1 Mainboard installation dimension drawing

2.2 Panel mounting dimensions

All sizes are in mm and accurate to 0.1mm

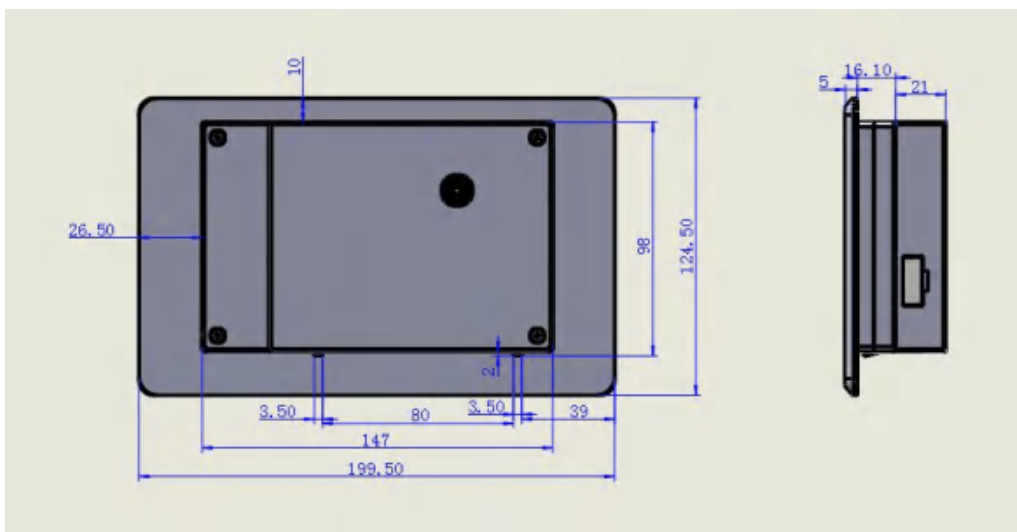

Fig.2-2 Panel installation dimension drawing

Section3 Physical drawings and interfaces

CONTENTS:

- Physical drawing of the mainboard
- Panel Physical Image
- Diagram of the electrical connection of the control

3.1 Physical drawing of the mainboard

For more detailed pin descriptions, see Chapter 4 Interface Signal Descriptions.

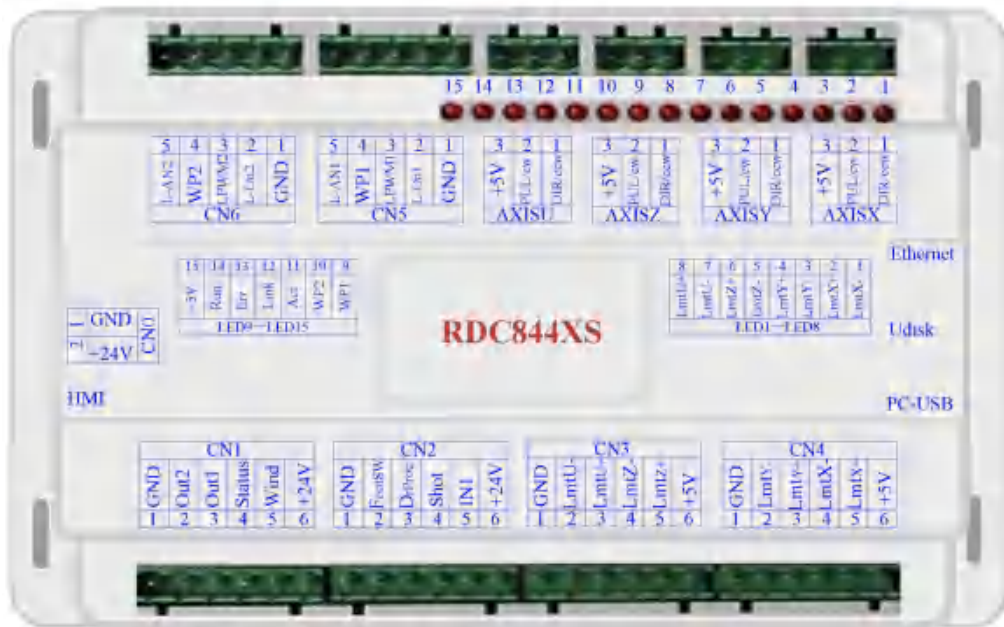

Fig.3-1 Physical drawing of the mainboard

3.2 Panel Physical Image

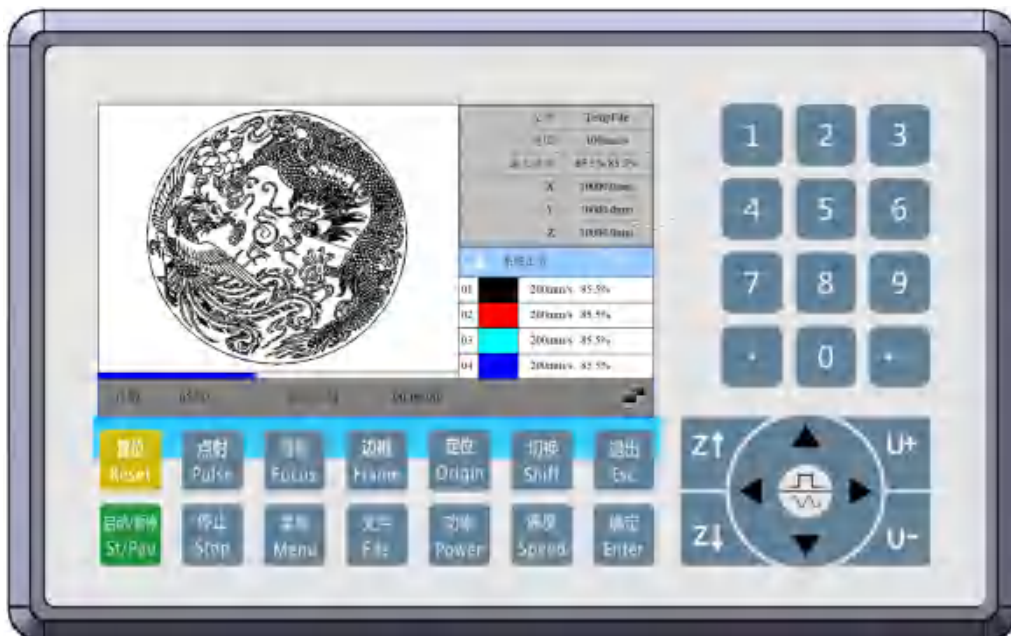

Fig.3-2 Panel Physical Image

3.3 Diagram of the electrical connection of the control system

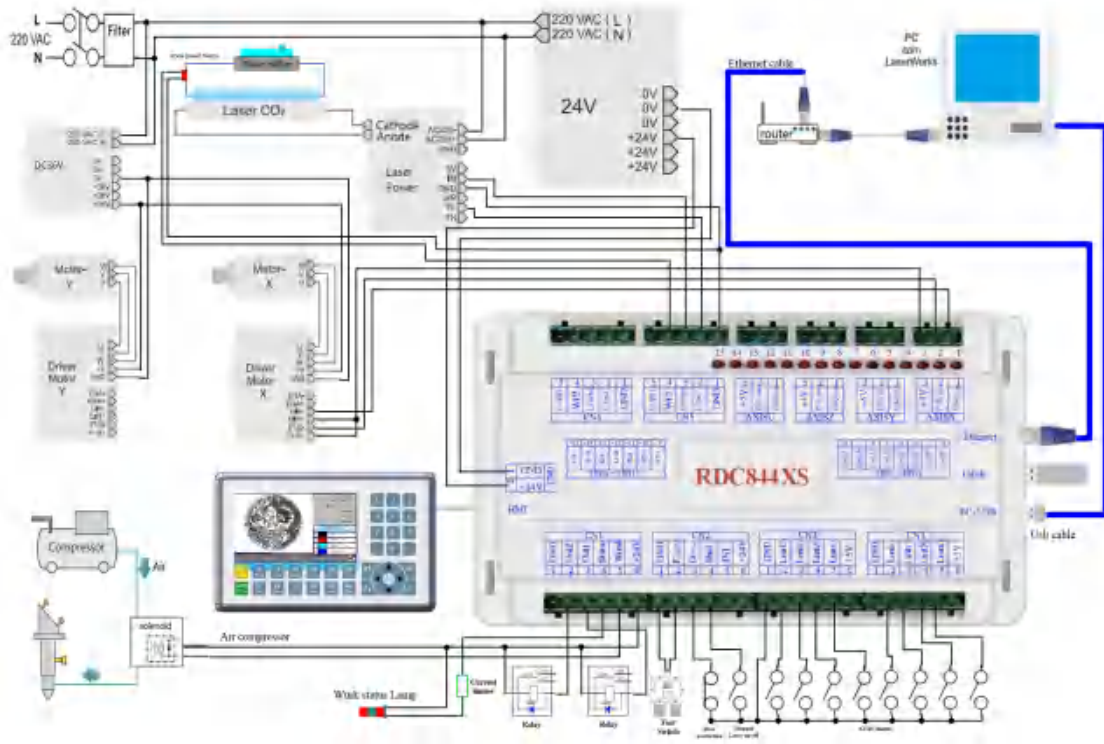

Fig.3-3 Diagram of the electrical connection of the control system

Section 4 Description of the mainboard interface signal

CONTENTS:

- Main power interface CN0
- Panel Signal-Cable Interface HMI
- Udisk Interface
- PC-USB Interface
- Ethernet Interface

4.1 Aain power interface CN0

Table 4-1 CN0 Port Definition

Pin	Symbols	Definition
1	GND	24V power ground (input)
2	+24V	24V power positive (input)

 The control system uses a single 24V power supply, in order to leave a certain margin, it is recommended to choose a power supply of 24V/2A or above.

4.2 Panel Signal-Cable Interface HMI

The panel signal-cable is a pin-to-pin cable, which is included in the factory shipper bill.

4.3 Udisk Interface

Udisk is a USB-AM interface. The controller may visit the u-disk by this interface.

4.4 PC-USB Interface

PC-USB is a USB-BM interface. The controller may communicate with PC by this port.

4.5 Ethernet Interface

Using this interface, the mainboard can communicate with PC by 10/100MHZ Ethernet.

 Pin to Pin Ethernet parallel line is recommended.

4.6 General/Dedicated Output interface CN1

Table 4-2 CN2 General/Dedicated Output Port Definition

Pin	Symbols	Definition
1	GND	Power Ground (Output)
2	Out2	General output, with the function reserved.
3	Out1	General output, with the function reserved.
4	Status	<p>Dedicated output, working status signal port (or second pen signal). When used as a working status signal, if a relay is externally connected to this port, the relay coil conducts during operation, remains unaffected during work pause, and the relay coil cuts off when work is completed or manually cancelled</p> <p>Dedicated output, when fan control is enabled, this port outputs the fan control signal; otherwise, it serves as the first pen control signal.</p>
5	Wind	When connected to a fan and fan control is enabled, the fan can be turned on/off separately for each layer. If a relay is externally connected, the relay coil conducts when the fan is turned on, and the relay coil cuts off when the fan is turned off.
6	+24V	Power output (24V if the main power interface is powered by a 24V supply, or 36V if the main power interface is powered by a 36V supply)

	<p>All output signals are optocoupled. OC gate output, maximum drive capacity of 300mA, can directly drive 6V/24V relays.</p>
---	---

4.7 General/Dedicated Input interface CN2

Table 4-3 Dedicated/General Input Interface Definition

Pin	Symbols	Definition
1	GND	Power Ground (Output)
2	FootSW	Dedicated input, foot switch input port. Connection method: When the foot pedal is pressed, a low-level signal is input to this port; when the foot pedal is released, either disconnecting from this port or inputting a high-level signal is acceptable. When the foot pedal is pressed for no less than 100ms: if the machine is currently idle, it will start working; if the machine is currently working, the work will be paused; if the machine is currently paused, the paused work will restart - meaning the foot switch functions similarly to the "Start/Pause" key on the keyboard. If the time between the second foot switch press and the first press is less than 100 milliseconds, the second foot pedal action will be considered invalid by the mainboard
3	DrProc	Dedicated input, protection signal input, if the machine needs to be protected in a specific state (such as cover opening protection), the protection signal is input from this pin. This pin can be enabled and disabled, when the pin is disabled, the signal is not queried by the motherboard, if the pin is enabled, when the input is high or the input port is suspended, the machine is protected, the work in progress is paused, and the laser is turned off.
4	Shot	General input, laser hardware pulse switch input port, when connected to low level, laser burst can be carried out, high level does not shoot.
5	IN1	General output, with the function reserved.
6	+24V	Power +24V (output)

4.8 Four-axis limit input interface CN3/CN4

Table 4-4 X/Y Axis Limit Interface CN4 Pin Definition

Pin	Symbols	Definition
1	GND	Power Ground (Output)
2	LmtY-	Y-: Limit for the Y-axis when moving to the 0 coordinate position
3	LmtY+	Y+: Limit for the Y-axis when moving to the maximum coordinate

4	LmtX-	position X-: Limit for the X-axis when moving to the 0 coordinate position
5	LmtX+	X+: Limit for the X-axis when moving to the maximum coordinate position
6	+5V	Power +5V (Output)

The limit polarity is optional. That is, when the moving axis reaches the limit position, a low-level signal is triggered, causing the corresponding limit LEDs to light up. When the moving axis leaves the limit position, a high-level signal is triggered, or the limit signal connection is disconnected, causing the limit indicator to turn off. In this case, the limit polarity is negative. Conversely, when the moving axis approaches the limit, the corresponding indicator is off, and when it leaves the limit, the corresponding indicator lights up, indicating a positive limit polarity. Incorrect limit polarity settings can cause the system to fail to detect limits during a reset, leading to axis collisions.

The Z/U axis limit interface CN3 has a pin definition similar to the X/Y axis limit interface CN4.

The XYZU four-axis limit input ports are compatible with 5V/12V/24V logic level inputs.

4.9 X/Y/Z/U Four-axis drive interface AXIS_X~AXIS_U

The four motion axis interfaces are the same, taking the X-axis interface AXIS_X as an example.

Table 4-5 X-axis interface AXIS_X definition

Pin	Symbols	Definition
1	DIR	Direction signal terminal (OC output)
2	PUL	Pulse signal terminal (OC output)
3	+5V	5V Power Supply Positive (Output, Driver Common Positive Method Only)

The direction signal polarity of the driver can be set. If a shaft is reset, it moves in the opposite direction to the origin of the machine, it means that the direction signal polarity of the shaft is not right, and the connection between the shaft and the motor driver can be disconnected at this time (otherwise the motherboard can not detect the limit, which may cause the shaft to collide), and then wait until the shaft is reset, and then correct the directional signal polarity of the shaft, and then press the reset button to reset the motherboard after the modification.

The pulse signal of the driver can be set to be active on the rising edge or active on the falling

edge, and the controller defaults to the falling edge when it leaves the factory.

	<p>Both the pulse signal and the direction signal are OC outputs, so the controller and motor driver must use the common anode connection method, and the common cathode and differential connection methods are not supported.</p>
---	---

4.10 Laser power control interface CN5/CN6

The control system has two independently adjustable laser power control interfaces. The signal meaning and sequence of the two interfaces are the same, taking the first interface CN5 as an example (the second laser power interface is CN6, and the pin definition is similar to CN5):

Table 4-6 Definition of the first interface CN5

Pin	Symbols	Definition
1	GND	Power ground (output)
2	L-ON1	<p>Laser-enabled control interface</p> <ol style="list-style-type: none"> 1. When the laser is the RF laser, this pin will not be used; 2. When the laser is a glass tube, if the used laser is outputted in the low-level form, this pin will be connected with the laser power enable end and used to control the ON/Off of laser.
3	LPWM1	<p>Power control interface of laser/laser tube</p> <ol style="list-style-type: none"> 1. When the laser is the RF laser, this pin will be connected with the laser RF-PWM end; 2. When the laser is a glass tube, this pin will be connected with the laser power PWM end and used to control the power of the laser.
4	WP1	<p>The input port of water protector for the first laser power source. When the water protector 1 is enabled, the mainboard will detect the input port of water protector 1. If this port is of low level, it will be deemed normal; if this port is of high level, the mainboard will forcibly close the laser to suspend the work in progress and the system will warn. If the water protector 1 is not enabled, the mainboard will not detect the input port of water protector 1 and so the water protector 1 can be unconnected.</p> <p style="text-align: center;">Water protection input must be 24V logic level.</p>
5	L-AN1	The analog signals for Laser Power. If Glass Tube is used, this pin is



		recommended to control the power of the Laser.
	Please select the correct laser type in the vendor's parameter settings.	

Section 5 Example of a laser power interface

CONTENTS:

- Overview
- Schematic diagram of laser power supply wiring for
- Schematic diagram of RF CO₂ laser wiring

5.1 Overview

The control system has two independently adjustable laser power control interfaces, which can control the glass tube laser power supply and RF CO2 laser.

When connecting different laser power supply types, please set the laser type correctly in the manufacturer's parameters, otherwise it may cause the switching light to be incorrect.

5.2 Schematic diagram of laser power supply wiring for glass tube

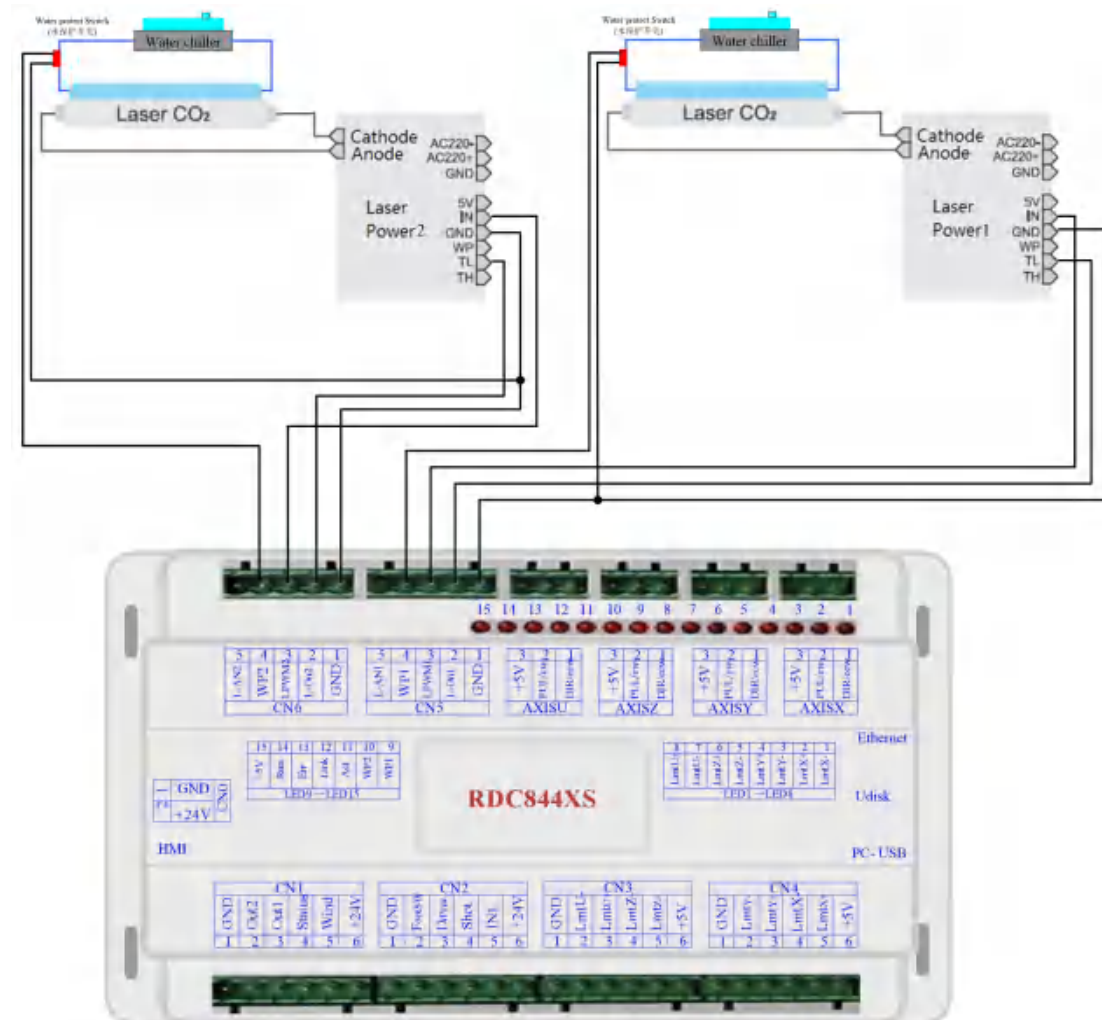

Fig.5-1 Schematic diagram of laser power supply wiring for glass tube

5.3 Schematic diagram of RF CO2 laser wiring

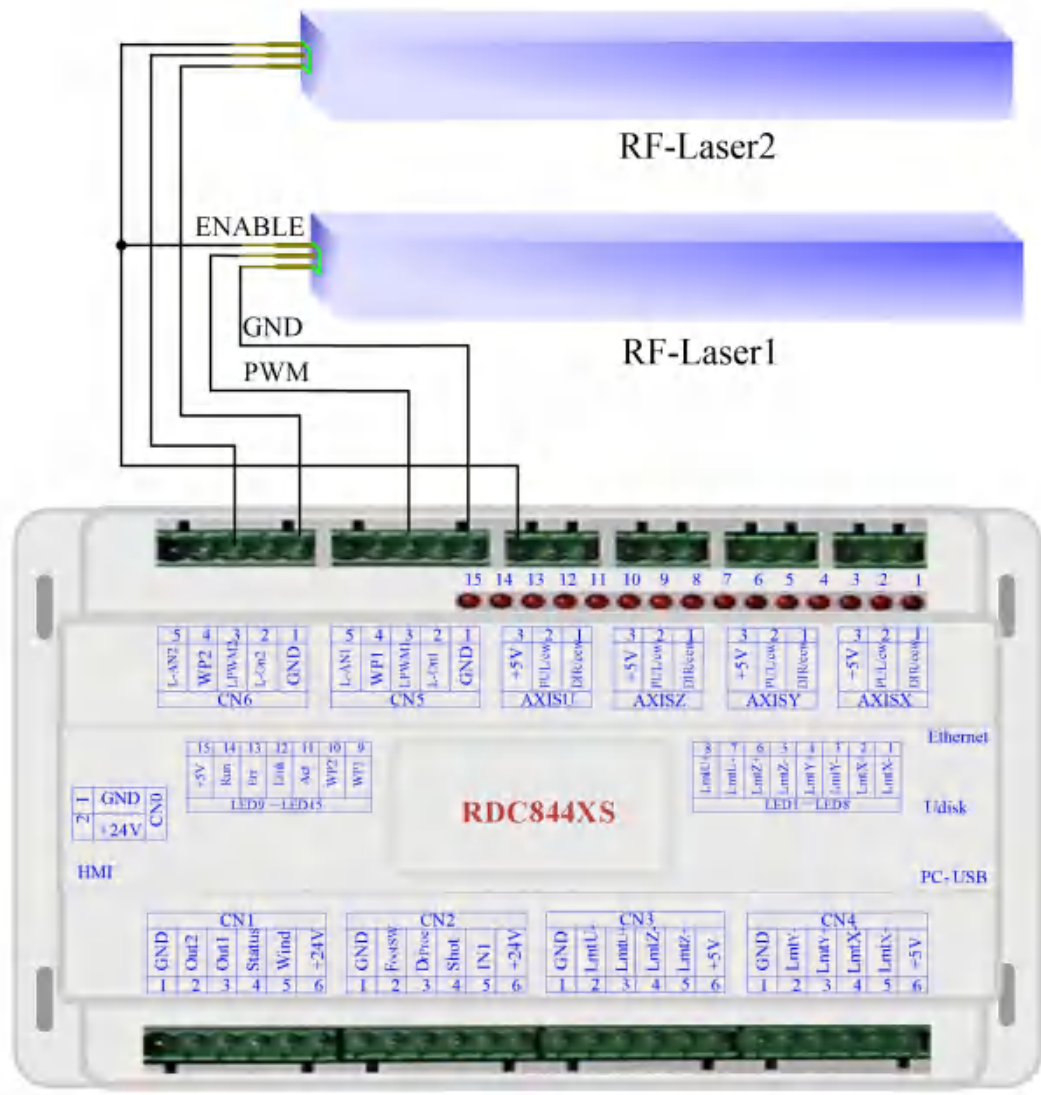

Fig.5-2 Schematic diagram of RF CO2 laser wiring

Section 6 Stepper motor driver interface

CONTENTS:

- Overview
- Schematic diagram of the drive wiring

6.1 Overview

For the stepper pulse signal, some of the isolated side optocoupler diodes walk from cut-off to on-step (that is, the falling edge of the pulse signal input from the negative end of the diode is valid), and some are the isolated side optocoupler diodes from the on-on to the cut-off step (that is, the rising edge of the pulse signal input from the negative end of the diode is valid).

When it is indicated whether the pulse signal of motor driver is the valid rising edge or the valid falling edge, it will be subject to the pulse signal inputted from the minus end of side OC diode.

Some of the input signals of the motor driver are independent, and some are internally co-positive, so some of the outward pinouts are 4 and some are 3 (only the pulse and direction signals are counted), as shown in Figure 6-1 and Figure 6-2.

Each motor driver interface of the RDC8445S mainboard provides a direction signal, a pulse signal, and a 5V signal for common yang connection, both pulse signal and direction signal are OC outputs.

The RDC8445S only supports a common anode connection and cannot be used with common cathode or differential connection methods. The polarity of the direction signal can be set via the PC, and whether the pulse signal is valid on the rising or falling edge can also be set through the PC.

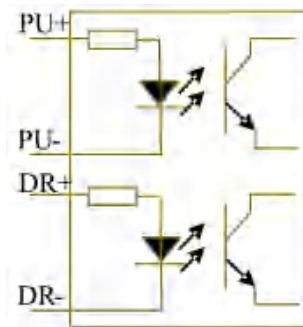

Fig.6-1. Four inputs, the driver input signal is independent

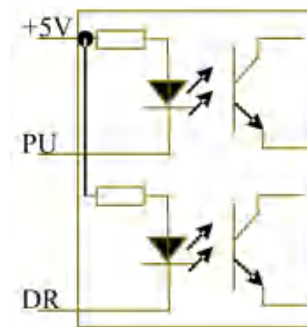

Fig.6-2 Three inputs, the driver input signal is mutual

6.2 Schematic diagram of the drive wiring

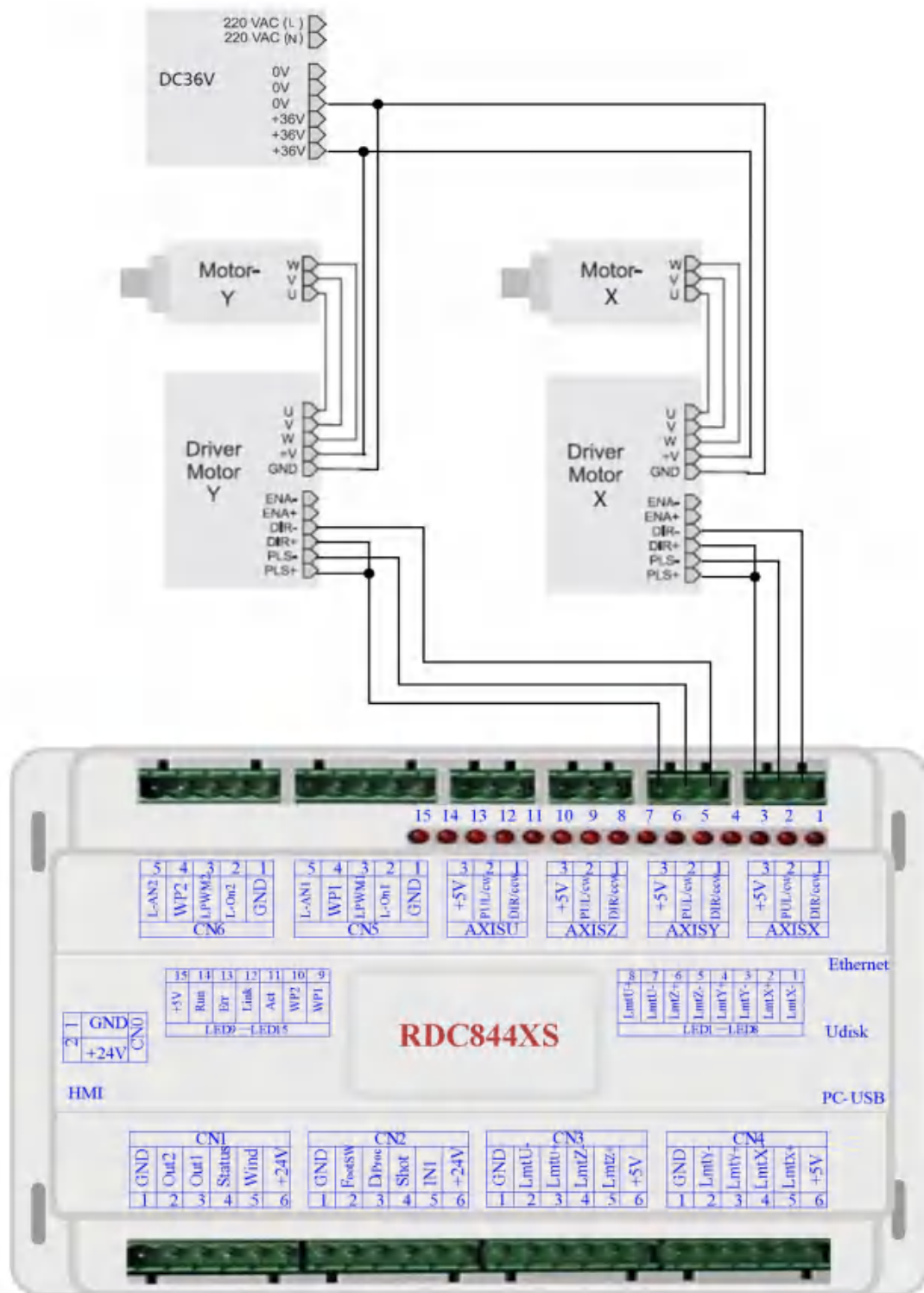

Fig. 6-3 Schematic diagram of driver wiring

Section 7 IO Port Wiring

CONTENTS:

- Input port
- Output

7.1 Input port

The two water protection input ports WP1 and WP2 of this controller are 24V logic, and all other input ports are compatible with 5V/12V/24V logic voltage.

The schematic diagram of the input port wiring is as follows:

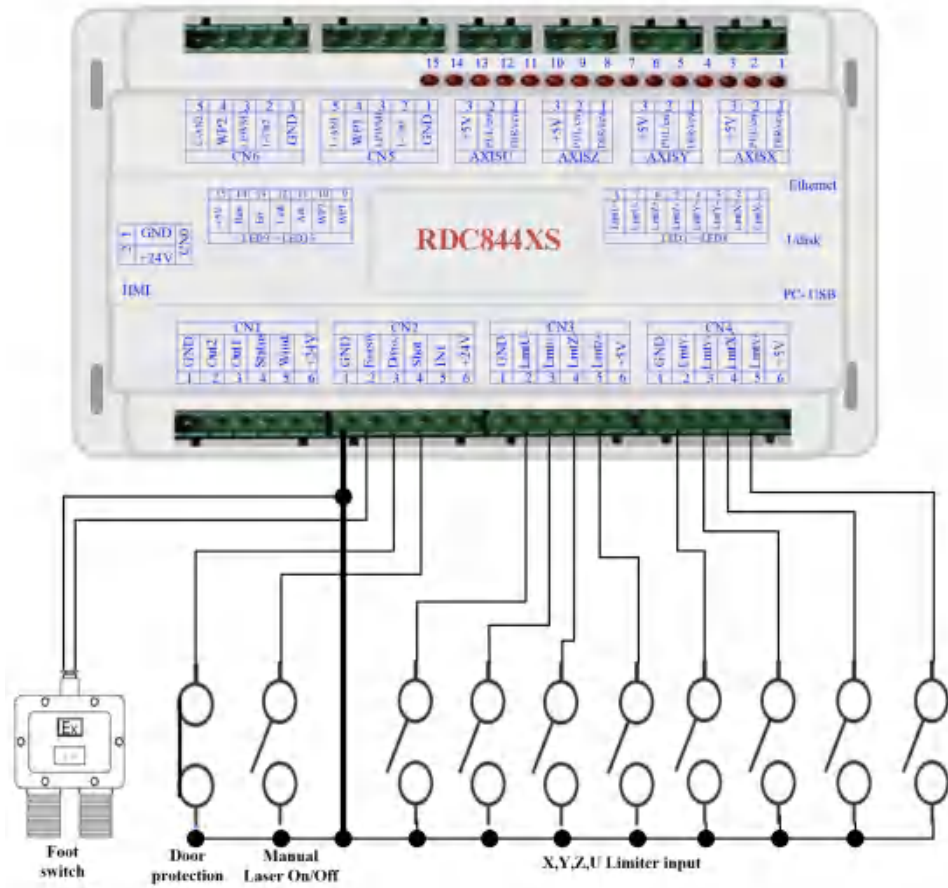

Fig.7-1 Schematic diagram of the input port connection

7.2 Output

All the output signals of this controller are all optocoupler isolation technology, OC gate output, its maximum driving capacity is 300mA, can directly drive 6V/24V relays, luminous indicators, buzzer alarm equipment, etc.

The schematic diagram of the output port wiring is as follows

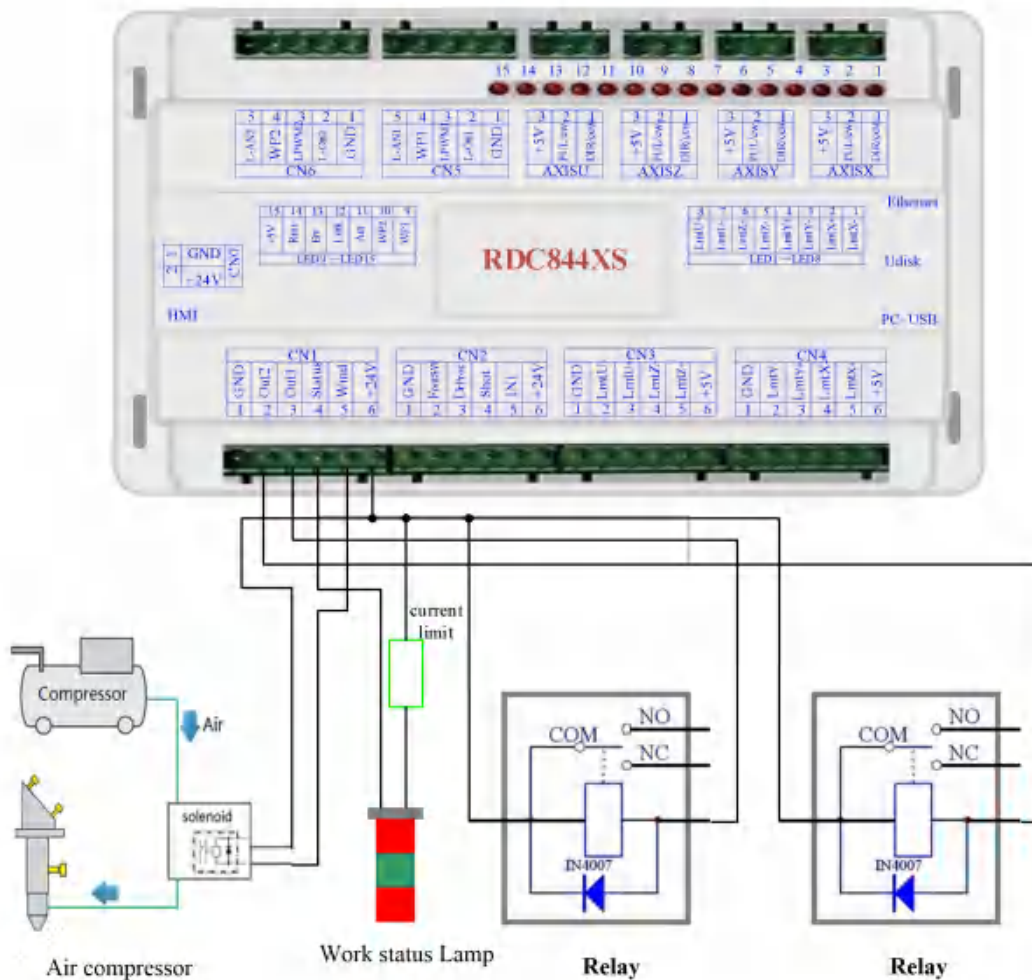

Fig.7-1 Example diagram of the output port connection

Section8 HMI operation

CONTENTS:

- Brief introduction
- Main interface features
- Power settings
- Layer function
- Menu function
- File management

8.1 Brief introduction

8.1.1 Overview

RDC8445S-HMI panel (hereinafter referred to as "panel") is a man-machine operation interface based on 5.0TFT LCD screen, which has the characteristics of beautiful interface, man-machine friendliness, smooth control and high cost performance. The panel can depict the controller movement trajectory in real time, allowing users to understand the current processing graphics at a glance, support file management, file preview, user and manufacturer parameter modification, support multi-Chinese interface switching and other functions.

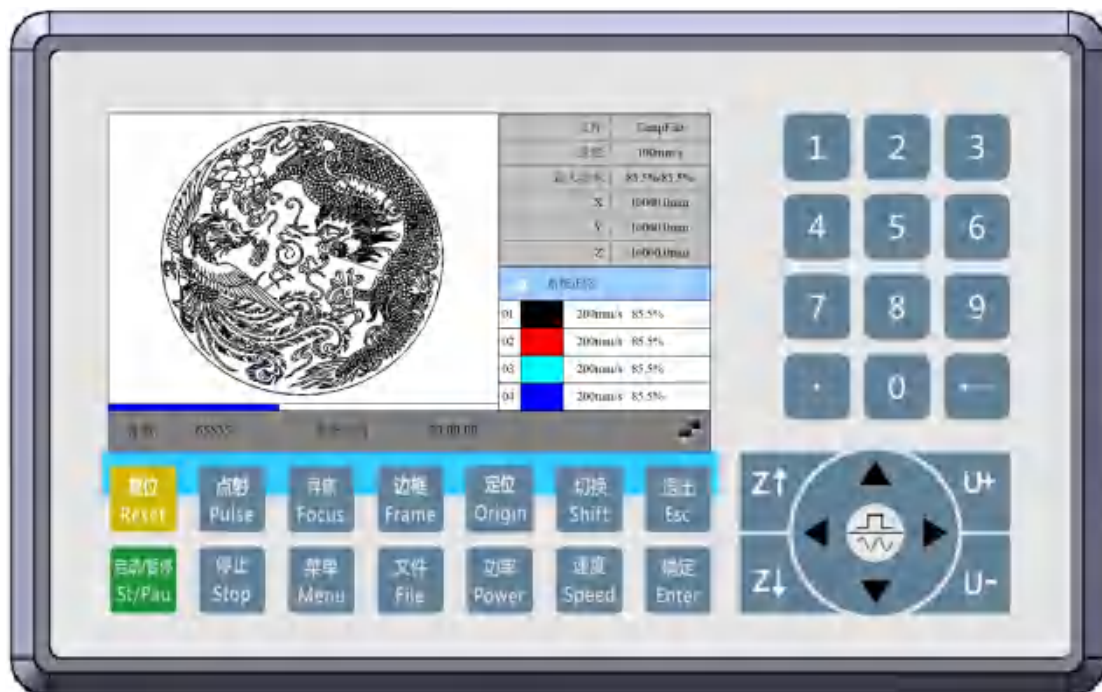







Fig. 8-1 Actual panel view

Panel characteristics:

- 5.0 inches TFT
- 854×480 resolution
- 64K colors
- RS232 Standard serial communication
- Buzzer

8.1.2 Key Functions

-  “Reset” Reset the whole system.
-  “St/Pau”: To start or pause the work.
-  “Pulse”: Laser on
-  “Pulse”: Stop working or motor axis motion.
-  “Focus”: Automatic searching for focus.
-  “Menu”: User parameters, factory parameters, language

settings, etc.

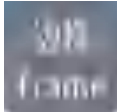
-  “Frame”: Perform a border operation on the current

processing file

-  “File”: memory file and USB flash drive file management

-  “Positioning key”: Set the positioning point

-  “Power”: Sets the current maximum and minimum

power values

-  “Shift”: Special function switching

-  “Speed”: Sets the current machining speed value

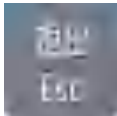
-  "Esc" key: used to return to the previous menu, cancel

parameter settings, etc

-  "Enter": Used for user confirmation

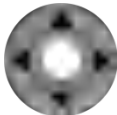
-  "arrow keys": Used when moving the X and Y axes or

setting parameters in the menu

-  "Z-axis" : Used to move the Z-axis

-  "U-axis": used to move the U-axis

-  "Jog/Continuous": Jog motion and continuous motion

toggle

-  "Decimal": Used to set parameters with decimals

-  "Delete": Used to delete parameters

Numeric keys 0~9: used to set parameters

8.1 Main interface features

When the system is powered on, the screen will show as below:

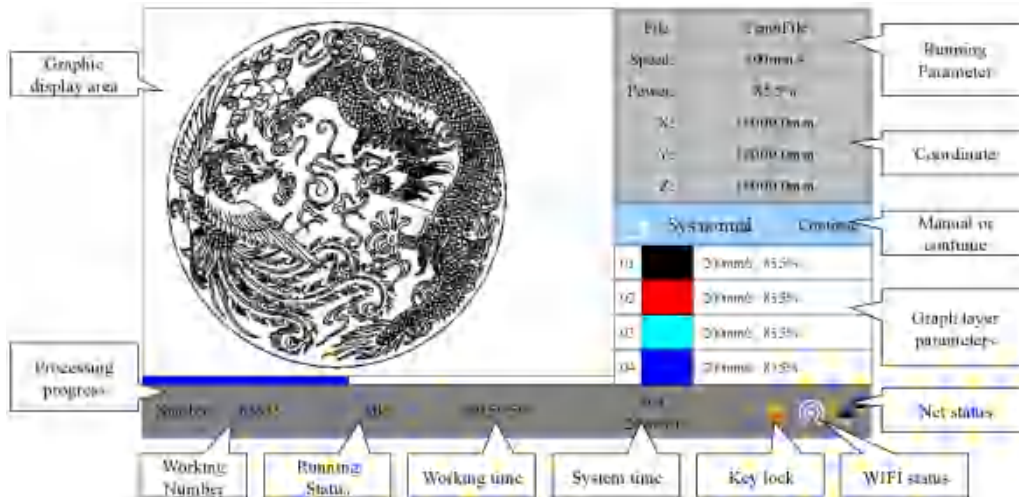







Figure 8-2 shows the main interface of the panel

- Graph display area: This area is used to depict the image of the processed file during the preview display and processing.
- Running Parameters: Displays the file number, speed, and maximum energy of the current processing file.
- Coordinate: displays the coordinate value of the current position of the laser head.
- Graph layer parameters: Displays the layer parameters of the current processed file or the layer parameters of the preview file, from left to right: layer number, layer color, layer speed, and layer maximum power.
- Running Status: used to display the current working status of the system, which are idle, paused, completed, and running. The processing time is displayed on the right.
- Processing progress: Displays the current processing progress
- Working Number: Displays the machined quantity of the current machining file.
- Net Status: It is used to display the status of the mainboard's connection to the network, and this area is displayed when the network communication is used and the connection is display , Otherwise, it is display .
- WIFI Status: It is used to display the status of the mainboard's WIFI startup, and this area will be displayed when the AP mode is used and the

hotspot is started ; This area is displayed when the STA mode is used and a connection is established , Otherwise, it is displayed .

- Key lock: when the keypad lock function is enabled, will display , If pressing any key does not respond and prompts you to enter the unlock code, you can unlock it only after entering the correct unlock code.

In the complete/idle state, the keys can be responded, and the user can perform file processing, parameter setting, file preview and other operations.

In the running/pausing state, some keys do not respond, such as positioning keys, border keys, file keys, etc.

Speed settings

Press the [Speed] button under the main interface, and the following interface will pop up:

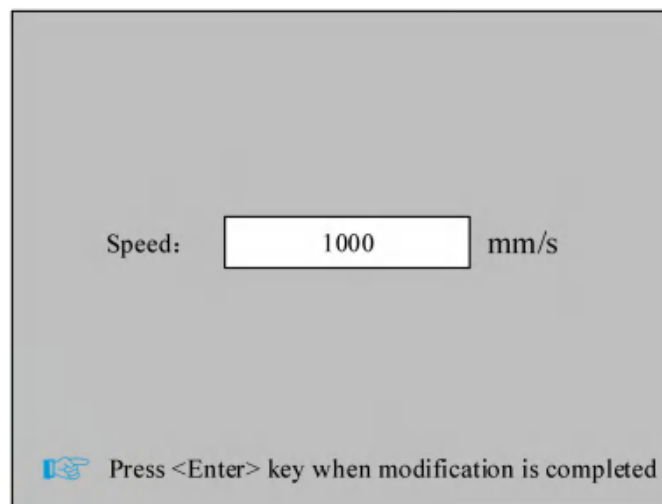

Figure 8-3 Speed Settings Interface

User can press the number key and delete key to set and modify the parameters, press the [OK] button to save the parameters after the modification is completed, press the [Esc] button to cancel the modified parameters, the interface disappears, and the main interface is returned.

8.2 Power settings

Press the [Power] button under the main interface, and the following interface will pop up:

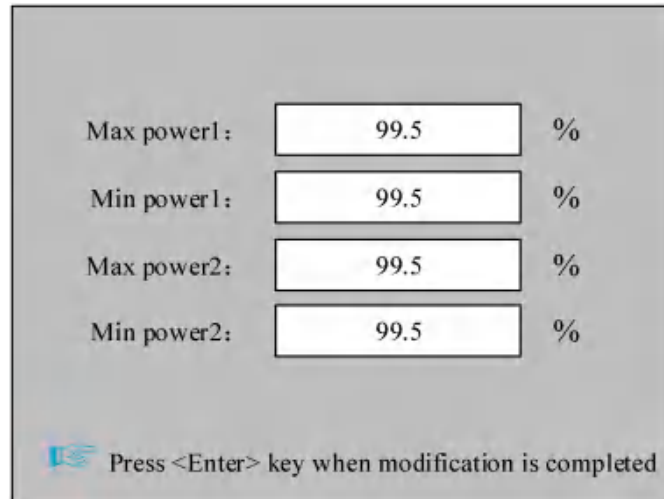

Figure 8-4 Power Setting Interface

The "blue selection block" stays on the first parameter to indicate that the parameter is selected, and the parameter can be set and modified by pressing the number key and delete key. Press the arrow keys to move the Selection Block to select other parameters to modify. When the parameters are modified, press the [OK] button to save the parameters, and press the [Esc] button to cancel the modified parameters, the interface disappears, and the main interface is returned.

8.3 Layer function

In the system complete/idle state on the main interface, if there is layer information in the layer parameter area, as shown in the following figure:



Figure 8-5 Layer parameter diagram

Press the OK button to select the layer parameter area, and then the "Blue Selection Block" appears in the first row of the layer list, as shown in the following figure:

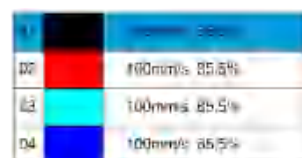

Figure 8-6 Layer parameter selection diagram

User can press the up and down keys to select the layer number, and the "Select Block" will also move, select the layer number you want to modify and press the [OK] button, and then the layer setting interface will pop up, as shown in the following figure:

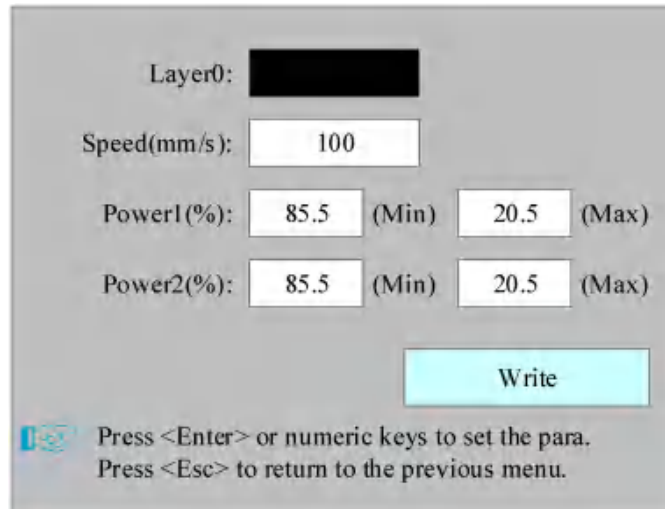



Figure 8-7 Layer Parameter Settings page

At this time, the "Blue Selection Block" stays on the layer number entry, and then you can press the [OK] key to enter the selection layer mode, and the "Blue Selection Block" becomes at the same time . Press the Up/Down key to select other layers, and then press the OK key to exit the layer selection mode. Then press the "Up/Down" key to move the "Selection Block" to the parameter entry of the layer you want to modify, press the number key and the delete key to set and modify the parameters, after setting the parameters, move the "Selection Block" to the "Write Parameters" entry and press the [OK] key to save the current layer parameters, the parameters will take effect, otherwise the parameters will not be saved. Press the [Exit] button to disappear and return to the main interface.

8.4 Menu function

Press the [Menu] button under the main interface, and the pop-up menu interface is as follows:

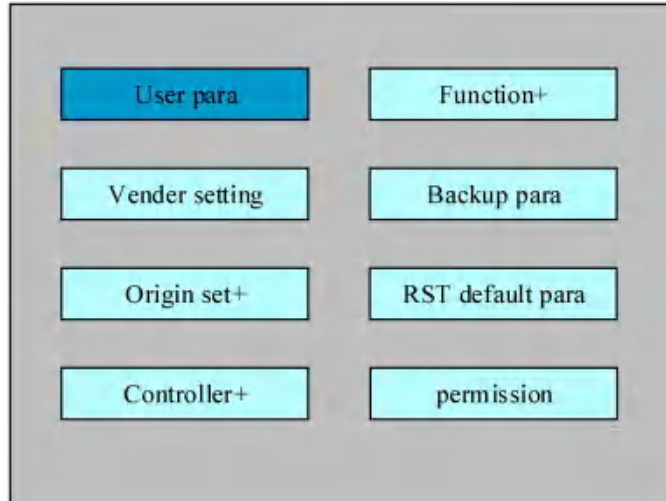

Figure 8-8 Menu interface diagram

Press the [Esc] key to return to the previous menu.

8.4.1 User parameters

Select the "User Parameters" entry under the menu interface, and press the [OK] button to pop up the following interface:

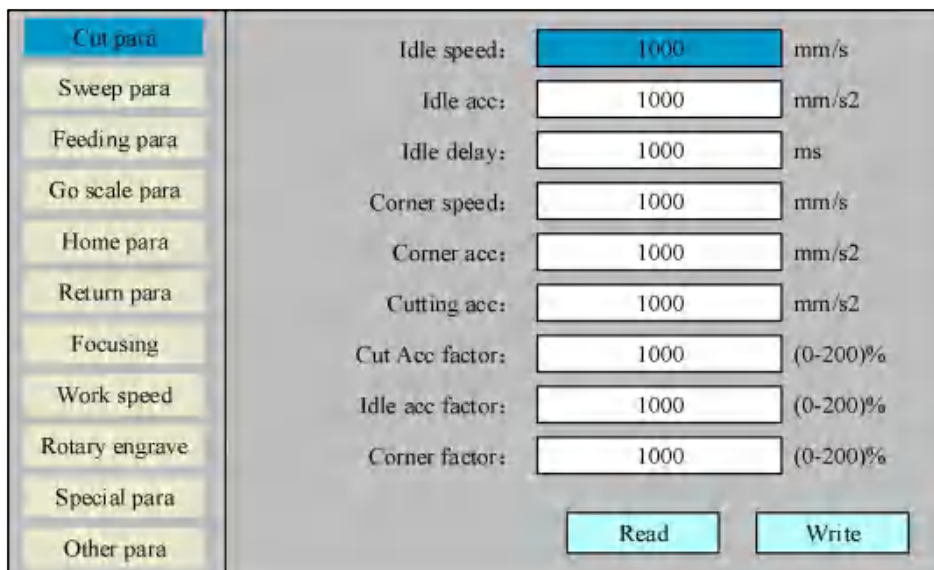

Figure 8-9 User Parameters

At this time, the panel automatically reads the motherboard parameters and displays them, and at the same time displays the progress of the read parameters on the "Read Parameters" entry. When all parameters are read, the user can press the "up/down" key to move the "blue selection block" to select a parameter classification such as "engraving", "feeding", etc., the right parameter area displays the corresponding parameters, if the user does not need to modify the parameters, then press the [exit] key to return to the previous menu.

If user need to modify the parameters, press the [OK] button, and then the "blue selection block" switches to the first parameter in the parameter area, as shown in the following interface:

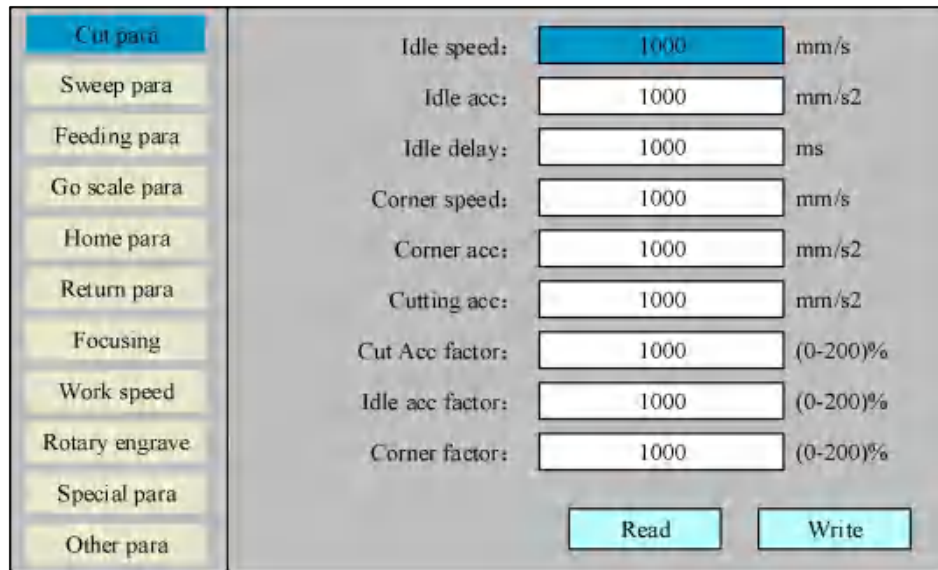



Figure 8-10 Cutting Parameter Setting Interface Diagram

At this time, the user can press the "Up/Down" key to select a parameter, press the number key to modify the numeric parameter (such as "Idle Speed"), and for non-numeric parameters (such as "Sweep Parameter"), press the [OK] key when the "Blue Selection Block" stops on the parameter to enter the modification mode (the right side of the "Blue Selection Block" changes ), Press the "Up/Down" button to modify the parameters, and press the [OK] button to exit the modification mode after the modification is completed. When the parameters of the current page are modified, move the "blue selection block" to the "Write Parameters" entry and press the [OK] button, the panel will save all the parameters on the motherboard and take effect, and display the saving progress on the "Write Parameters" entry. If you want to check whether the parameters are saved successfully, you can move the "blue selection block" to the "Read parameters" entry and press the [OK] button, then the panel will re-read the motherboard parameters and display them. When you press the [Esc] button, the "Blue Selection Block" switches back to the parameter category, as shown in Figure 8-9, then you can select another parameter category to modify or press the [Esc] button to return to the previous menu.

The operation of other interfaces is similar, and the interface is displayed as follows:

Cut para	X axis speed:	<input type="text" value="1000"/>	mm/s
Swap para	Y axis speed:	<input type="text" value="1000"/>	mm/s
Feeding para	Z Axis:	<input type="text" value="1000"/>	mm/s
Go scale para	Y Axis:	<input type="text" value="1000"/>	mm/s
Home para	Y Axis:	<input type="text" value="1000"/>	mm/s
Return para	Unit shift speed:	<input type="text" value="1000"/>	mm/s
Focusing	Start mode:	<input type="text" value="Normal"/>	
Work speed	Focus offset:	<input type="text" value="1000"/>	mm/s
Rotary engrave	Logarithmic factor:	<input type="text" value="1000"/>	mm/s
Special para		<input type="button" value="Read"/>	<input type="button" value="Write"/>
Other para			

(a) Engraving parameters

Cut para	Delay before feed:	<input type="text" value="1000"/>	s
Swap para	Delay after feed:	<input type="text" value="1000"/>	ms
Feeding para	Progressive feeding:	<input type="text" value="No"/>	
Go scale para	Feeding compensation:	<input type="text" value="1000"/>	mm
Home para	Last feeding:	<input type="text" value="Yes"/>	
Return para		<input type="button" value="Read"/>	<input type="button" value="Write"/>
Focusing			
Work speed			
Rotary engrave			
Special para			
Other para			

(b) Feeding parameters

Cut para	Go scale mode:	<input type="text" value="Close laser"/>	
Swap para	Go scale blank:	<input type="text" value="1000.000"/>	mm
Feeding para		<input type="button" value="Read"/>	<input type="button" value="Write"/>
Go scale para			
Home para			
Return para			
Focusing			
Work speed			
Rotary engrave			
Special para			
Other para			

(c) Frame parameters

Cut para	XY home speed:	<input type="text" value="1000.000"/>	mm/s
Swap para	Z home speed:	<input type="text" value="1000.000"/>	mm/s
Feeding para	U home speed:	<input type="text" value="1000.000"/>	mm/s
Go scale para	Auto home X:	<input type="text" value="Yes"/>	
Home para	Auto home Y:	<input type="text" value="Yes"/>	
Return para	Auto home Z:	<input type="text" value="Yes"/>	
Focusing	Auto home U:	<input type="text" value="Yes"/>	
Work speed	Return after reset:	<input type="text" value="Home position"/>	
Rotary engrave		<input type="button" value="Read"/>	<input type="button" value="Write"/>
Special para			
Other para			

(d) Reset parameters

Cut para	Return position:	<input type="text" value="Origin"/>	
Swap para	Enable decoding Z:	<input type="text" value="No"/>	
Feeding para	Decoding point X:	<input type="text" value="1000.000"/>	mm
Go scale para	Decoding point Y:	<input type="text" value="1000.000"/>	mm
Home para	Decoding point Z:	<input type="text" value="1000.000"/>	mm
Return para		<input type="button" value="Read"/>	<input type="button" value="Write"/>
Focusing			
Work speed			
Rotary engrave			
Special para			
Other para			

(e) Return parameters

Cut para	Focus enable:	<input type="text" value="No"/>	
Swap para	Focus depth:	<input type="text" value="1000.000"/>	mm
Feeding para	Material thickness:	<input type="text" value="1000.000"/>	mm
Go scale para	Focusing type:	<input type="text" value="No"/>	
Home para		<input type="button" value="Read"/>	<input type="button" value="Write"/>
Return para			
Focusing			
Work speed			
Rotary engrave			
Special para			
Other para			

(f) Focus parameters

Cut para	Z work speed:	<input type="text" value="1000.000"/>	mm/s
Swap para	U work speed:	<input type="text" value="1000.000"/>	mm/s
Feeding para	Key lift speed:	<input type="text" value="1000.000"/>	mm/s
Go scale para	Key lift speed:	<input type="text" value="1000.000"/>	mm/s
Home para		<input type="button" value="Read"/>	<input type="button" value="Write"/>
Return para			
Focusing			
Work speed			
Rotary engrave			
Special para			
Other para			

(g) Working speed

Cut para	Enable rotating:	<input type="text" value="No"/>	
Swap para	Circle pulse:	<input type="text" value="1000.000"/>	
Feeding para	Diameter:	<input type="text" value="1000.000"/>	mm
Go scale para	Rotating axis:	<input type="text" value="Axis Y"/>	
Home para		<input type="button" value="Read"/>	<input type="button" value="Write"/>
Return para			
Focusing			
Work speed			
Rotary engrave			
Special para			
Other para			

(h) Rotating



(i)Special parameter

(j)Other parameter

Figure 8-11 The user parameter settings screen

8.4.2 Manufacture parameters

Select the "Manufacture Parameters" entry under the menu interface, enter the manufacturer parameter password correctly (see Section 8.8 for details), press the [OK] button to pop up the X-axis parameter interface (Y, Z and U-axis parameter interface are the same as the X-axis parameter interface), and the query and setting operation of the manufacturer's parameters is the same as the operation of the user parameters, which will not be repeated here. The manufacturer parameter interface is as follows:

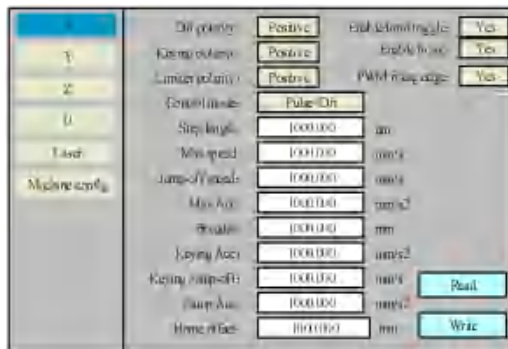

(a)X-axis parameter interface diagram

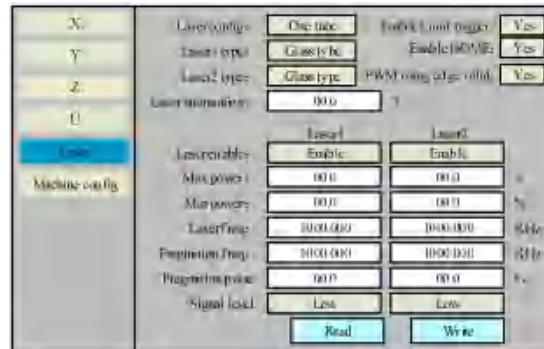

(b)Laser parameter interface diagram

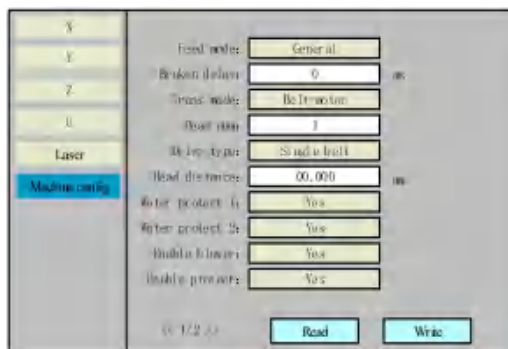

(c) Machine configuration parameter interface diagram (page 1)

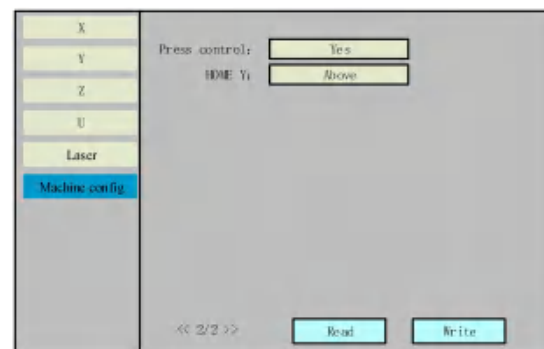

(d) Laser parameter interface diagram (page 2)

2)

Figure 8-12 Manufacturer parameter interface diagram

8.4.3 Positioning settings

Select the "Positioning Settings" entry under the menu interface, press the [OK] button, and the following interface will pop up:

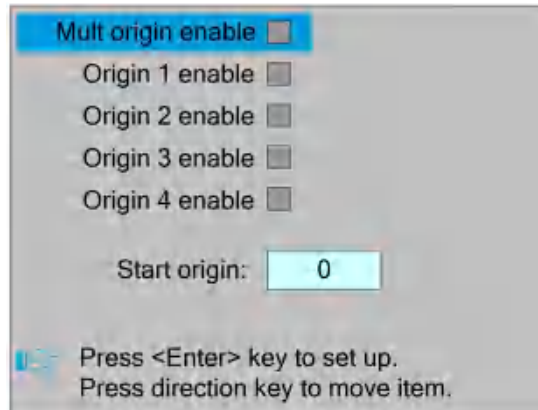

Figure 8-13 positioning Settings

The "Blue Selection Block" selects the "Multi-positioning Enable" entry by default, and press the [OK] button to select or cancel the entry (when selected, the small square on the right will show red. **Mult origin enable**), When multiple anchors are enabled, the little finger is turned to the "Anchor 1 Enabled" entry to indicate that the anchor 1 is set up, first move the "blue selection block" to the "Anchor 1 Enable" entry and press the [OK] button to enable it, then press the [Switch] button to change the coordinate value of the X/Y axis, then press the [Positioning] button to set the current coordinate value to the anchor point 1, and finally press the [Switch] key to return to the current interface operation. The operation process interface is as follows:

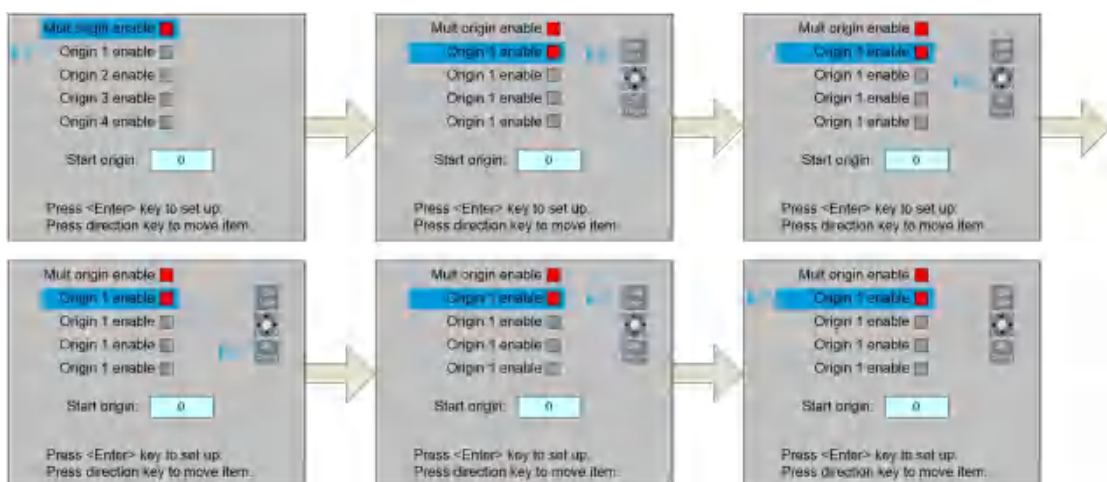

Figure 8-14 Operation diagram of multi-anchor settings

The rest of the settings are the same as above.

When the "Selection Block" stops on the "Start Anchor" entry, press the [OK] key to enter the modification, press the "Up/Down" button to modify, press the [OK] button after the modification, the parameter will take effect automatically, and press the [ESC] key to return to the previous menu.

The details of each sub-item are as follows:

- Multi-positioning enable: Yes and No are optional. When No is selected, the system uses single-anchor logic to press the Anchor key on the keyboard to set the anchor point, and only the anchor point you set has effect. When Yes is selected, the system uses multi-anchor logic and the Locate key on the keyboard has no effect. You need to set the values for each anchor in the menu, as described below.
- Start positioning: 0~4 optional, showing the anchor point that will be used in the next image that is about to work. Anchor point 0 indicates the anchor point set by the "Positioning" key on the panel in the single anchor point logic, and 1~4 indicates the anchor point sequence number in the multi-anchor logic. You can modify the next anchor point to any point of 1~4, so as to control the starting point position of the next work (provided that the anchor point is enabled), and cannot be modified to the 0 anchor point (if it is a single anchor logic, always take the 0 anchor point).
- Positioning 1~4 enabled: When multi-anchor logic is enabled, four anchors can be disabled and enabled separately.



Once the multi-positioning logic is selected, assuming that the starting anchor sequence number is 1 and all four anchors are enabled, when the memory file is started (including keyboard boot and PC boot), or when the PC uses direct output to start the work and the "Use original anchor as anchor" option is selected, each time the job is started with a different anchor point, and the anchor rotation order is 1->2->3->4->1->2..... If you select "Use current point as anchor point" when the PC uses direct output to start work, the system will always use the current point as the anchor point.

8.4.4 Controller settings

Select the "Controller Settings" entry under the menu interface, press the [OK] button, and the controller settings interface will pop up, as shown in the following figure:

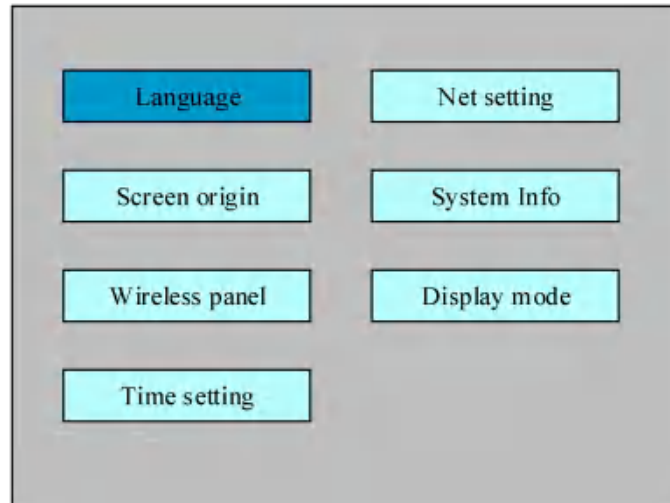

Figure 8-15 Controller Setup Interface

Press the [Esc] key to return to the previous menu.

8.6.4.1. Language settings

When the "Blue Selection Block" is stopped on the entry, press the [OK] key, and the following interface will pop up:



Figure 8-16 The language settings page

Press the arrow keys to select a language, press the [OK] button, the setting will take effect, and you will automatically return to the main interface.

8.6.4.2. Screen origin setting

When the "Blue Selection Block" is stopped on the entry, press the [OK] button, and the following interface will pop up:

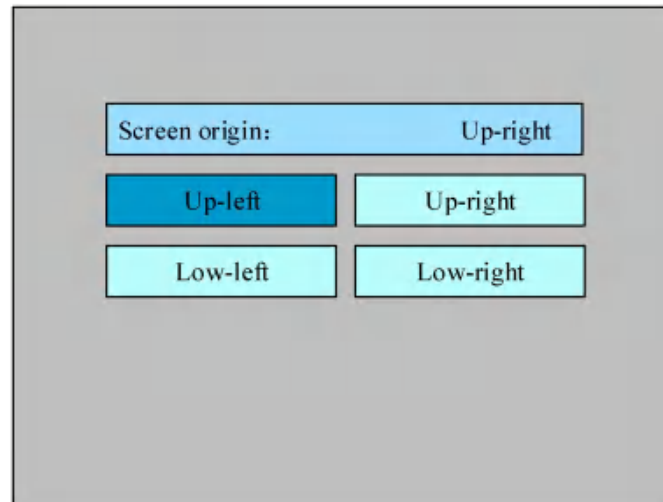

Figure 8-17 Screen origin setting

Here user can set the origin position of the display screen and select a different screen origin position to mirror the display graphic in different X/Y directions. Press the arrow keys to select a language, press the [OK] button, the setting will take effect, and you will automatically return to the main interface.

8.6.4.3. Wireless panel setup

When the "Blue Selection Block" is stopped on the entry, press the [OK] key, and the following interface will pop up

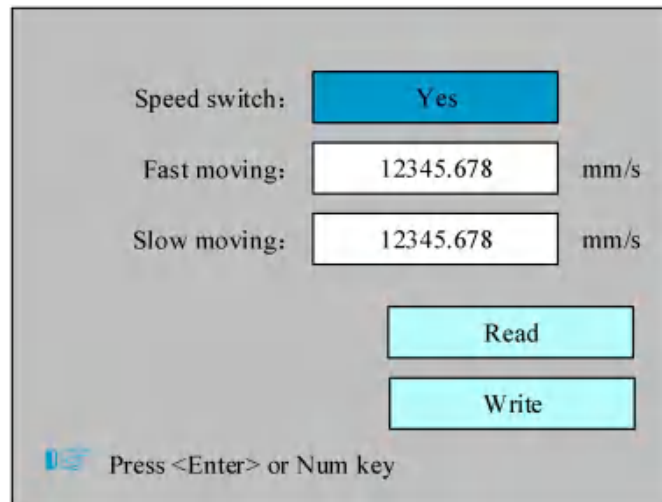



Figure 8-18 The Infinite Panel Settings screen

When modifying the first parameter, press the OK key to enter the modification mode (the right side of the "Blue Selection Block" becomes like this ), Press the "Up/Down" button to modify, and press the [OK] button to exit the modification mode after the modification is completed. Press the arrow keys to select other parameters, press the number keys to modify the parameters, after the modification is completed, move the "selection block" to the "write parameters" entry, press the [OK] key, the parameter setting takes effect, press the [Exit] button to return to the previous menu.

8.6.4.4. Time setting

When the "Blue Selection Block" is stopped on the entry, press the [OK] key, and the following interface will pop up:

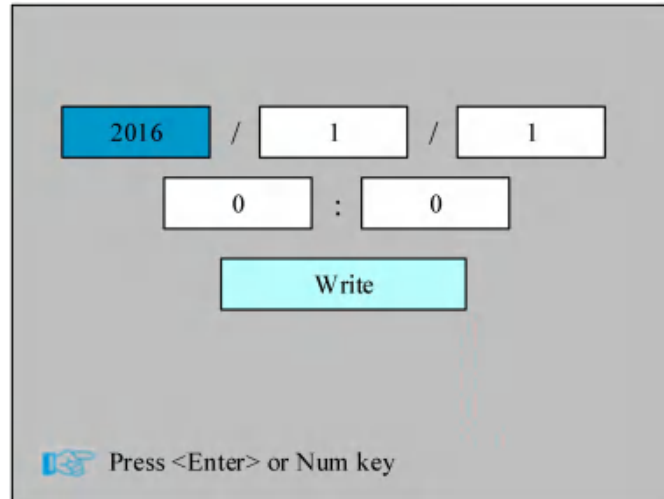

Figure 8-19 shows the time setting screen

8.6.4.5. Network configuration

When the "Blue Selection Block" is stopped on the entry, press the [OK] key, and the following interface will pop up:

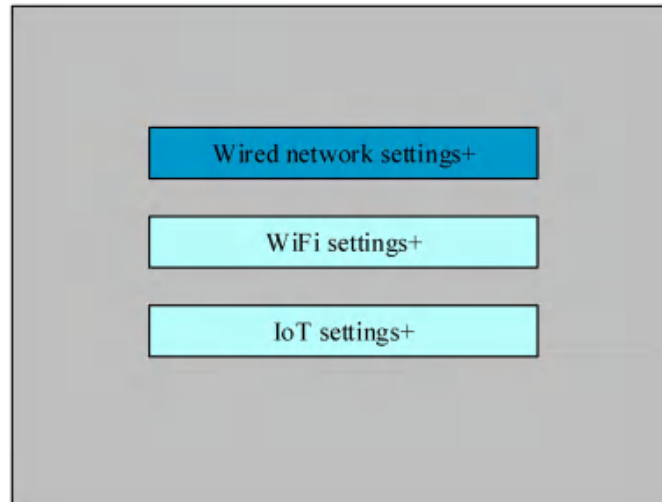

Figure 8-20 Network configuration interface

- **Network settings with cable**

Press the arrow keys to stop the "Blue Selection Block" at [Network Settings+] and then press the [ok] button, the following interface will pop up:

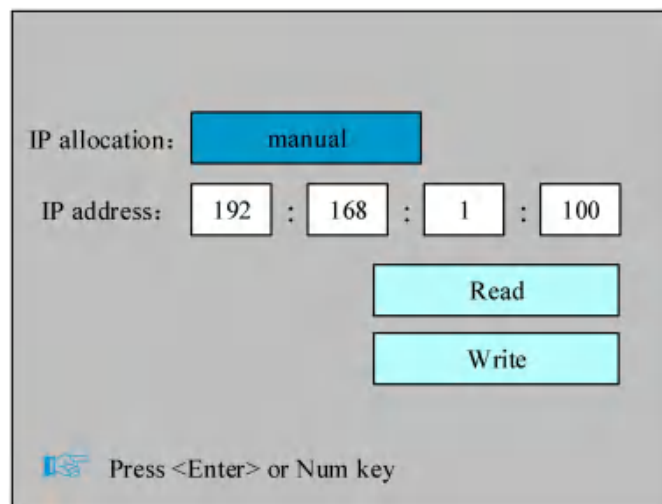

Figure 8-21 Wired network settings interface

IP assignment methods include "automatic" and "manual". When setting the IP allocation method, move the "Select Block" to "IP Assignment", press the [Confirm] button, and select the IP allocation method by pressing the up and down arrow keys. When you select Automatic, the motherboard will automatically set the available IP address based on network conditions; if you select Manual, you need to press the arrow keys to select a parameter and then press the

number keys to modify the IP address. After the modification is completed, move the "Selection Block" to the "Write Parameters" entry, press the [OK] button, the parameter setting takes effect, and press the [Exit] button to return to the previous menu.

- **WiFi settings**

Press the arrow keys to stop the "Blue Selection Block" in "WiFi Settings+" and press the [ok] button, the following interface will pop up:

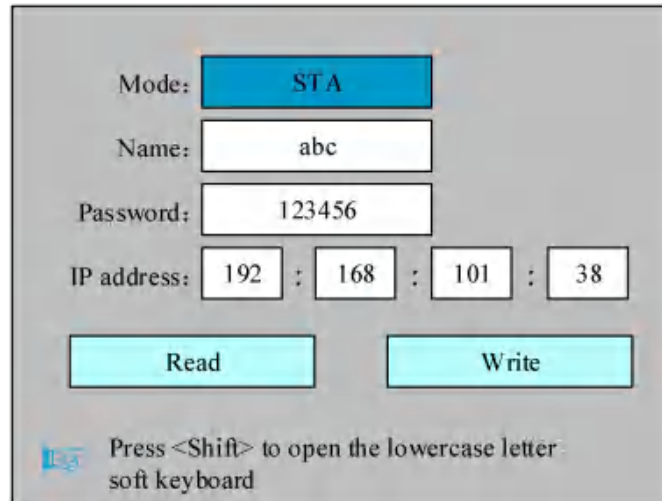

Figure 8-22 WiFi settings

WiFi modes include "STA" and "AP". When setting the WiFi mode, move the "Select Block" to "Mode", press the [ok] button, and select the mode by pressing the up and down arrow keys.

- **STA Mode**

When "STA" is selected, the motherboard can connect to other web servers as a client. Move the "selection block" to the "name", you can directly press the number key to enter the WiFi name, or you can press the [Switch] key to use the keypad, press the arrow key to select a number or letter, press the [OK] button to select, and then press the [Switch] key to return. Move the "selection block" to the "password", you can directly press the number key to enter the WiFi name, or press the [Switch] key to use the keypad, press the arrow key to select a number or letter, press the [OK] button to select, and then press the [Switch] key to return. Finally, move the "Selection Block" to "Write Parameters" and press the [OK] button. The WiFi connection interface is as follows:

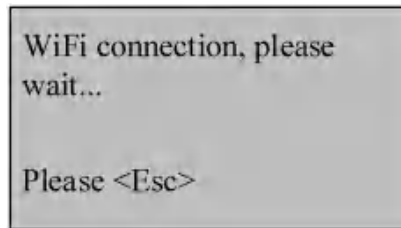
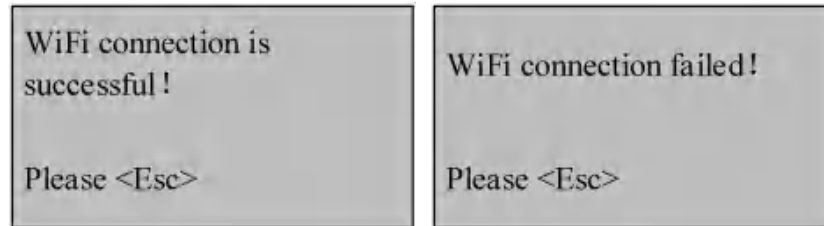

Figure 8-23 STA connection prompt

If the password is entered correctly, it will prompt "WiFi connection successful!" ; If the password is entered incorrectly, the message "WiFi connection failed!" will be displayed.



(a)The connection is successful

(b)The connection failed

Figure 8-24 SAT mode connection result

➤ AP Mode

AP modes include AP_2.4G and AP_5G, and the frequency bands are different in the two modes. When AP is selected, the motherboard serves as a server to provide a hotspot for clients to connect. Move the "Selection Block" to "Write Parameters" and press the [ok] key. The hotspot startup screen is as follows:

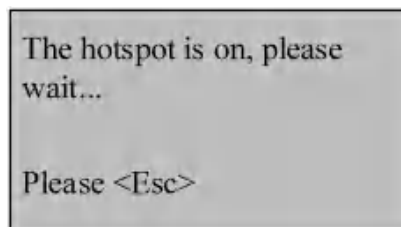

Figure 8-25 AP connection prompt

After waiting for the motherboard hotspot to be successfully activated, it prompts "Hotspot turned on successfully", and press the [ESC] button to enter the WIFI setting interface. The hotspot launch page is as follows:

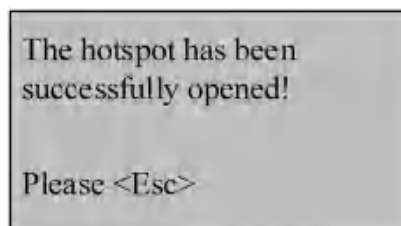
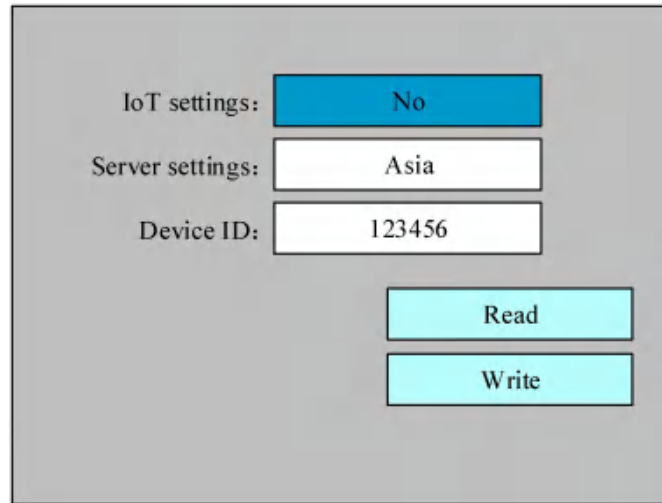

Figure 8-26 The AP mode is successfully started

After the setting is complete, move the "Select Block" to "Read Parameters" and press the [OK] button to read out the IP address.

IoT Settings

Press the arrow keys to stop the "Blue Selection Block" in "IoT Settings+", and then press the [ok] button, and the following interface will pop up:



IoT settings:	<input type="button" value="No"/>
Server settings:	<input type="button" value="Asia"/>
Device ID:	<input type="button" value="123456"/>
	<input type="button" value="Read"/>
	<input type="button" value="Write"/>

Figure 8-27 IoT settings



The WiFi name, password, and IP address cannot be set in AP mode.

In STA mode, you cannot set an IP address, but an IP address is automatically assigned after the connection is successful.

8.6.4.6. System Information

When the "Blue Selection Block" is stopped on the entry, press the [OK] key, and the following interface will pop up:

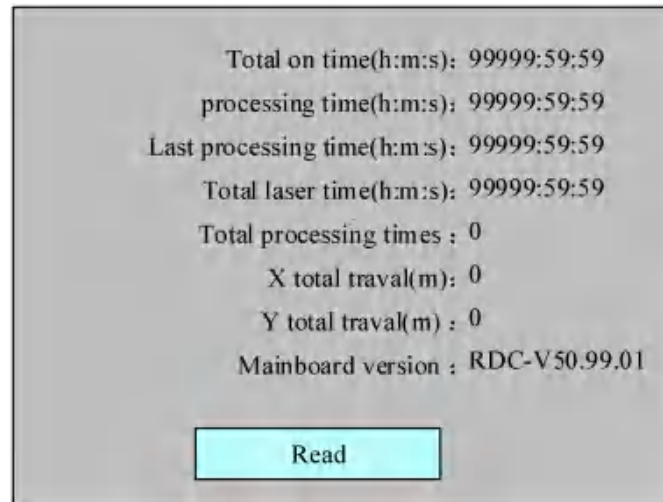

Figure 8-28 System Information Interface

Press the [OK] button to read the mainboard information, and press the [Esc] button to return to the previous menu.

8.6.4.7. Display mode

When the "Blue Selection Block" is stopped on the entry, press the [OK] key, and the following interface will pop up:

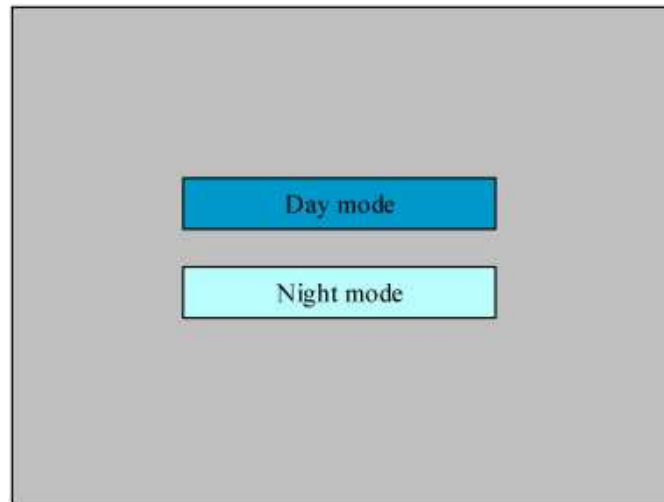

Figure 8-29 shows the mode interface

8.4.5 Function

Select the "Function" entry under the menu interface, press the [OK] button, and the controller setting interface will pop up as follows:

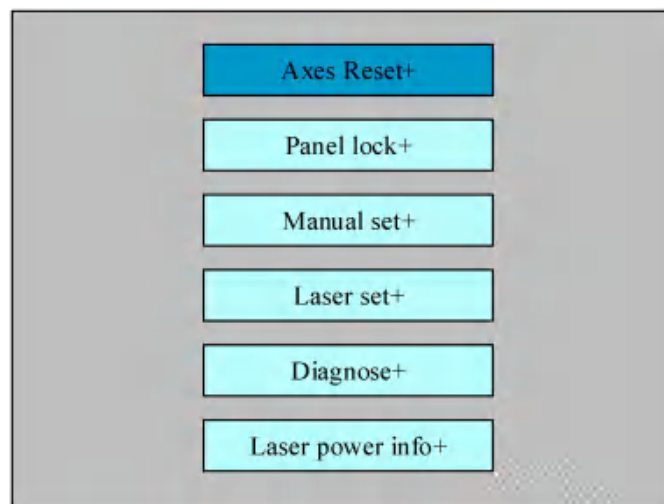

Figure 8-30 Function Interface

Press the [Esc] key to return to the previous menu.

Note: The laser power supply information function will only be displayed after "Show laser power supply information" is checked in the manufacturer settings of the RDWorks software.

8.6.5.1. Each axis is reset

When the "Blue Selection Block" is stopped on the entry, press the [OK] key, and the following interface will pop up:

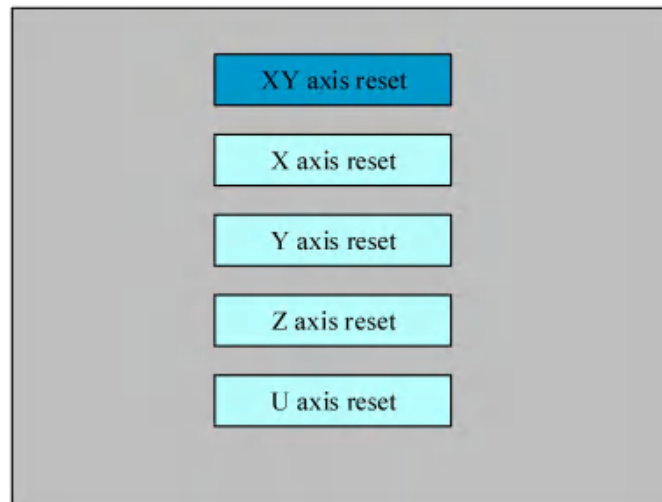

Figure 8-31 Reset interface diagram of each axis

Press the arrow keys to select an entry and press the [OK] key, the system performs the axis reset, and prompts "Reset...".

Press the [Esc] key to return to the previous menu.

8.6.5.2. Keypad lock function

When the "Blue Selection Block" is stopped on the entry, press the [OK] key, and the following interface will pop up:

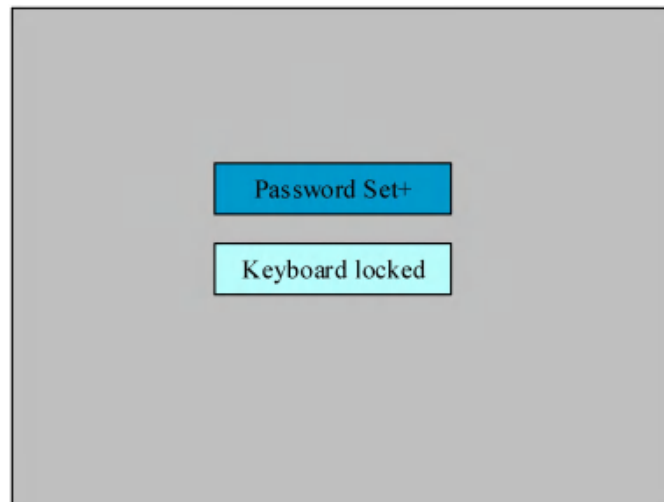

Figure 8-32 Diagram of the keypad lock function interface

- Password settings

This entry can set the default password for keypad locking, and use the new password to lock the keys after the setting is successful.

- Keypad locked

This entry can lock the key, after entering the correct password, the key will automatically lock and return to the main interface, when pressing any key, the interface prompts to enter the password to unlock the key.

Please refer to Section 8.8 for details on how to enter and set the password.

Press the [Esc] key to return to the previous menu.

8.6.5.3. Jog settings

When the "Blue Selection Block" is stopped on the entry, press the [OK] key, and the following interface will pop up:

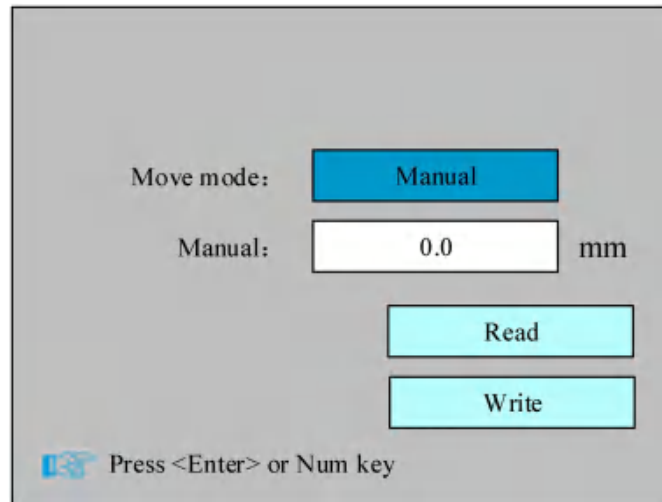



Figure 8-33 Jog Settings Interface

Jog mode has continuous and jog options, press the [OK] key to enter the modification mode (the right side of the "blue selection block" becomes ), Press the "Up/Down" button to modify, and press the [OK] button to exit the modification mode after the modification is completed. After all the modifications are completed, move the "Select Block" to the "Write Parameters" entry, press the [OK] button, the parameter settings will take effect, and press the [Esc] button to return to the previous menu.

When the jog mode is "continuous", the jog parameter does not work, when the arrow key is pressed, the axis moves, and when the arrow key is flicked, the axis stops moving; When the jog mode is "jog", the corresponding motion axis runs once every time the arrow key is pressed, and the distance is equal to the value of the jog distance set by the user (without exceeding the width of the machine).

8.6.5.4. Pulse settings

When the "Blue Selection Block" is stopped on the entry, press the [OK] key, and the following interface will pop up:

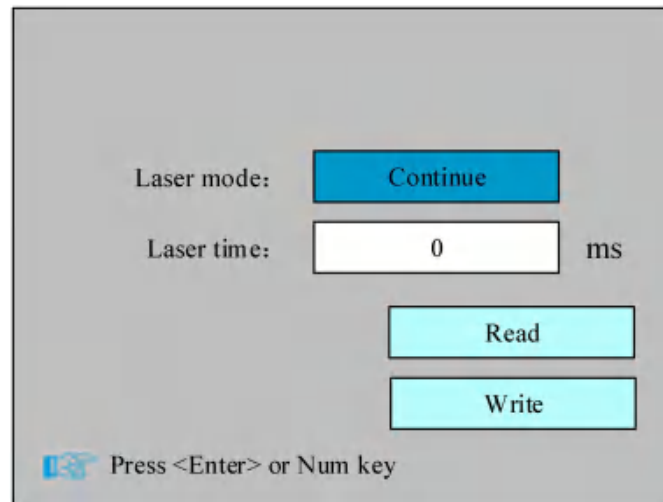

Figure 8-34 pulse Setup Interface

The operation method is the same as the jog setting. If the burst mode is selected as "Continuous", the laser will always be lit when the dot shot key is pressed, and the laser will be turned off when the point shot key is flicked. If "Burst Shot" is selected for the burst mode, the laser will emit light once every time you press the burst button, and the burst time will be the burst time value set by the user.

8.6.5.5. Diagnosis

When the "Blue Selection Block" is stopped on the entry, press the [OK] key, and the following interface will pop up:

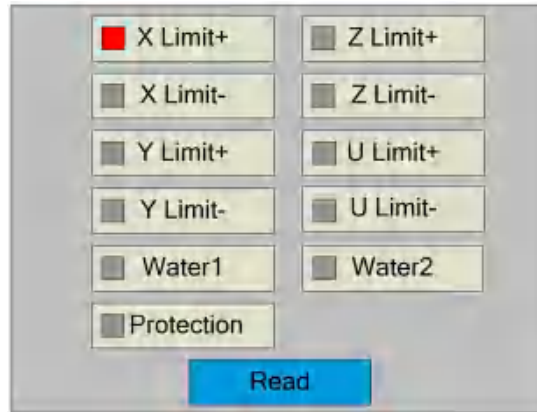

Figure 8-35 Diagnostic interface

When the hardware signal is triggered, the small box on the left of the corresponding entry will be displayed in red, otherwise it will be gray, press the [Exit] key to return to the upper menu.

8.6.5.6. Laser power supply information

When the "Blue Selection Block" is stopped on the entry, press the [OK] key, and the following interface will pop up:

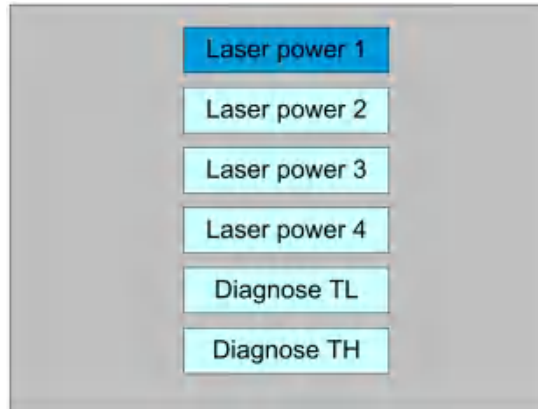

Figure 8-36 Laser power supply information interface diagram

When the "blue selection block" stops at the laser power supply 1, 2, 3, and 4 respectively, press the [OK] button to view the information of each power supply separately, and the interface is as follows:

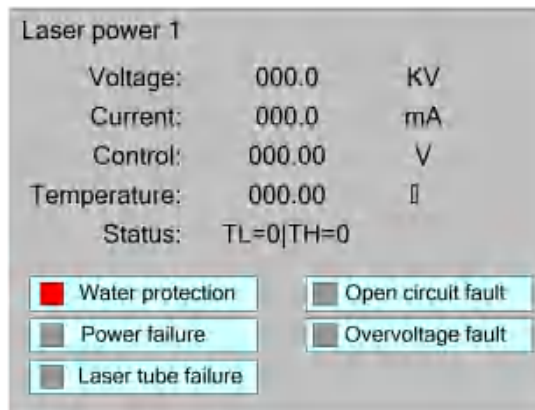

Figure 8-37 Laser power supply 1 power supply information interface diagram

When the "blue selection block" stops at the "Diagnostic TL" and "Diagnostic TH" entries respectively, press the [OK] button, the system checks whether the laser power supply is abnormal, and if so, an alarm will be generated.

Press the [ESC] key to return to the previous menu.

When the "blue selection block" stops at the "Diagnostic TL" and "Diagnostic TH" entries respectively, press the [OK] button, the system checks whether the laser power supply is abnormal, and if so, an alarm will be generated.

Press the [ESC] key to return to the previous menu.

8.4.6 Back up factory parameters

Select the "Backup Factory Parameters" entry under the menu interface, press the [OK] button to pop up the password input interface, please refer to Section 8.9 for the password input operation, if the password is entered correctly, the system will back up all the current manufacturer parameters and user parameters as factory parameters, and the interface prompts "Setting parameters successfully".



When the machine leaves the factory, use the function of "backup factory parameters" to back up all the debugged manufacturer parameters and user parameters, and then at any time, you can use the "restore factory parameters" to restore all manufacturer and user parameters with one click.

8.4.7 Restore factory parameters

Select the "Backup Factory Parameters" entry under the menu interface, press the [OK] button to pop up the password input interface, please refer to Section 8.9 for password input operations, if the password is entered correctly, the system will use the factory parameters set before to restore all the current user parameters and manufacturer parameters. The displayed message "Parameters Restored Successfully" is displayed.

8.4.8 Permissions management

Select the "Permission Management" entry under the menu interface, and press the [OK] button to pop up the permission management interface. Move the "Select Block" to "Change Authorization Code" and press the [Confirm] button to start changing the authorization code.

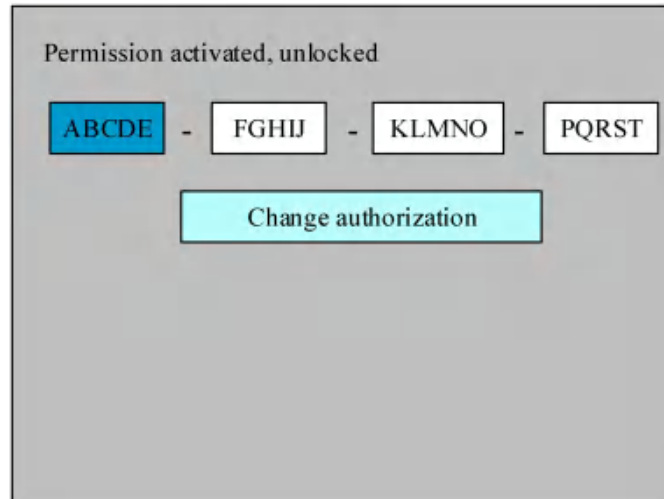

Figure 8-38 Permission Management page

Figure 8-39 shows the interface for changing the authorization code, move the Select Block to the location of the authorization code to be modified, press the OK button to pop up the keyboard, press the arrow keys to select a number or letter, press the OK button to select it, and then press the Exit key to return. Repeat the above operations to modify the authorization code. After the modification is complete, move the "Select Block" to the position of "Confirm Authorization Code", and press the [OK] button. If the authorization code is incorrect, a prompt of "non-compliant authorization code" will pop up; if the authorization code is correct, a message "Setup Successful" will pop up.

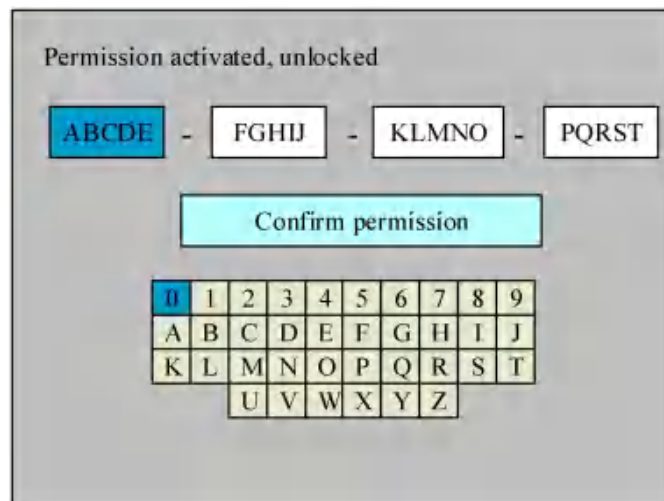

Figure 8-39 The interface for changing the authorization code is displayed

	The authorization code must be obtained in the RDWorks software
--	---

8.5 File management

8.5.1 Memory files

Under the main interface, press the [File] button, and the following interface will pop up::

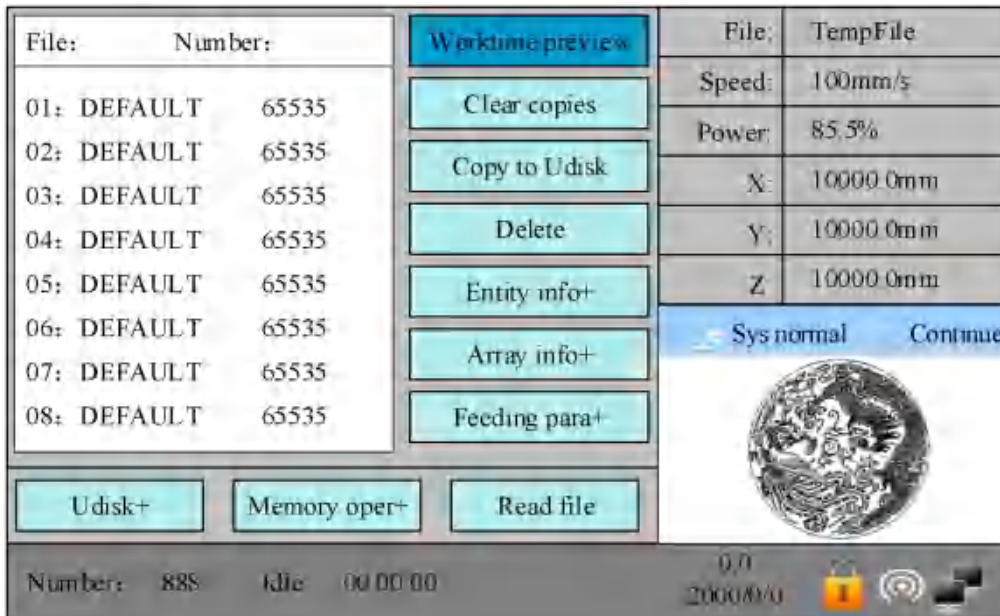

Figure 8-40 The file interface is displayed

When entering this interface, the controller will automatically read the memory files of the system, the file name and the number of processed parts will be displayed on the list, and the selected files will be previewed in the preview area on the right. When there are multiple files, press the up and down keys to select a file, the file will be previewed, and the graph will be displayed in the upper right corner of the interface. When you press the [OK] key, the file will be previewed on the main interface, and the current file dialog box will be closed, if you want to cancel the preview, press the [ESC] key.

Press the left and right keys to switch back and forth between the left file list and the right item with a blue square, indicating that the list or item is activated, which is convenient for the user, if the file is previewing, the file preview will be canceled when switching to the item . When the "Blue Selection Block" stops on an item, User can press the up and down keys to select the item and press [OK] to activate the item.

Press the [Exit] button to return to the main interface

The entries on the right and bottom read as follows:

Working hours preview: Predict the total machining time of selected Chinese parts, and the prediction time and actual running time are only millisecond-level errors.

Zero: Clears the number of processed pieces of the selected file.

Copy to USB flash drive: Copies the selected files to a USB flash drive.

Delete Files: Deletes the selected files.

Element Info+: Displays the element information of the selected file.

Pattern Info+: Displays the array information of the selected file.

Feeding Parameters+: Displays the feeding parameter information of the selected file.

USB flash drive+: USB flash drive file menu.

Memory Operation: Enter the memory operation sub-menu.

Read Memory Files: Read the list of memory files. Memory operations

8.5.2 Memory operations

Select the "Memory Operation" entry in the interface above and press the [OK] button, and the pop-up menu will be displayed as shown in the following figure:

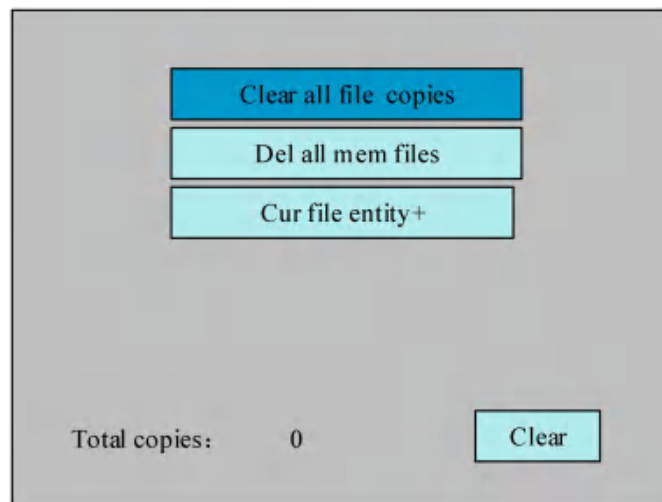

Figure 8-41 Memory operation interface

- **Clear all count:** To clear the running times of every file in the memory
- **Delete all file:** To delete all memory files
- **Format memory:** To format memory speedily, and then all the files in memory will be deleted.
- **Total:** the total running times of all the files.

Methods of operation are the same as above. Press the <Esc> key to return to the previous menu.

8.5.2.1. The current file element

In the memory operation interface, select the Current File Element entry and press OK, and the pop-up menu is displayed as shown in Figure 8-43. The interface displays the element information of the file that is currently being processed.

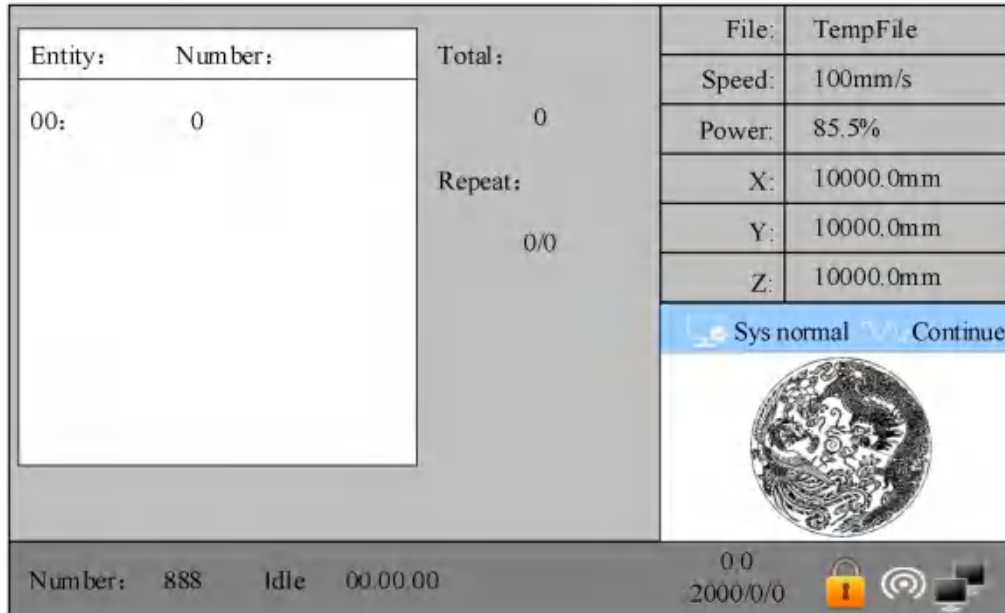

Figure 8-43 Diagram of the pixel interface of the current file

8.5.3 USB flash drive file

Select the "U disk" entry on the "File" interface, press the [OK] button, and the list of U disk files will pop up, as shown in the figure:

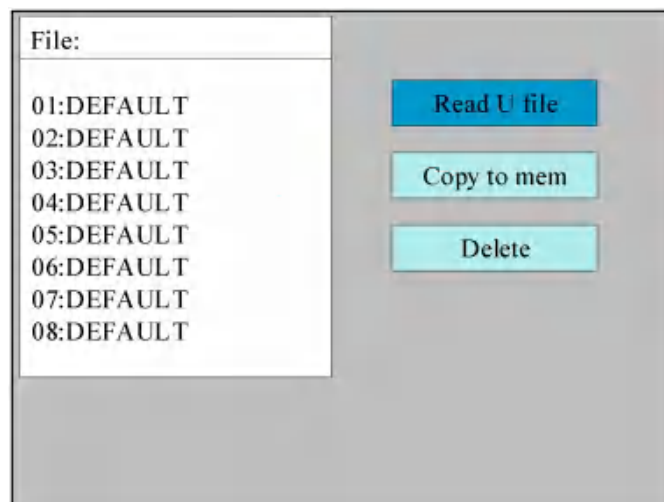



Figure 8-44 USB flash drive interface

The operation method is the same as that of memory files, press the [Exit] key to

return to the "File" interface.

- **Read Udisk:** read the file list in the Udisk;
- **Copy to memory:** copy the target Udisk file to the memory;
- **Delete:** delete the selected Udisk file;
-

	<p>This system supports the FAT32 and FAT16 file formats of the U disk, the system can only recognize the file in the root directory of the U disk, the file name of more than 16 characters will be automatically cut off by the system, the file name supports Chinese, English and numbers. Files copied from the motherboard to the USB flash drive are placed in the root directory of the USB flash drive.</p>
---	--

8.6 Password entry and settings

8.6.1 Password entry

When entering certain interfaces or performing certain operations, you need to enter a password, and the pop-up interface is as follows:

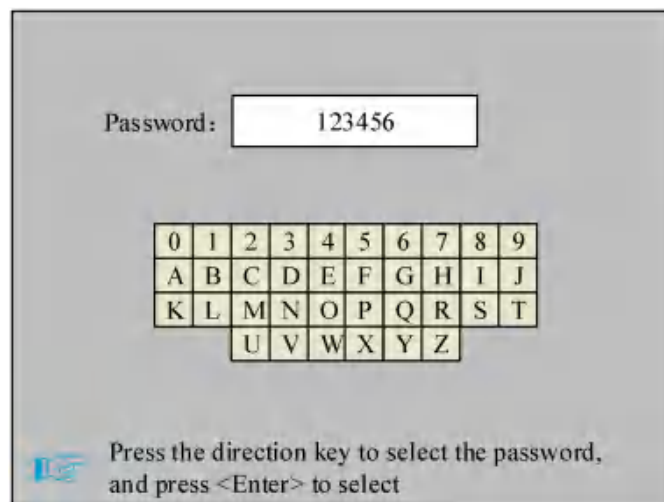

Figure 8-45 The password input page

At this time, you can directly press the number key to enter the password, or you can press the arrow keys to select a number or letter, press the [OK] key to select, and press the [OK] key when entering 6 passwords, if the password is correct, then enter the next interface or perform the operation, otherwise it will display "password error", and re-enter. Press the [Esc] key to return to the previous menu.

8.6.2 Password settings

The password setting page is shown in the following figure:

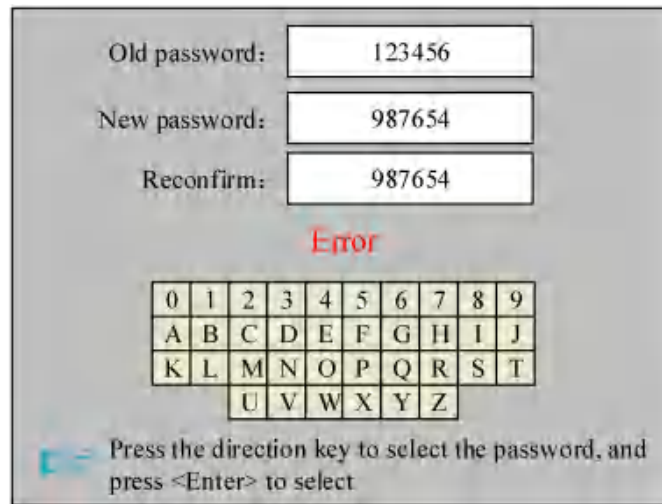

Figure 8-46 Password Setting

User can directly press the number key to enter the password, or you can press the [Switch] key to use the keypad, press the arrow key to select a number or letter, press the [OK] key to select, and then press the [Switch] key to return to the password selection. If the password is entered correctly, the new password will take effect, otherwise "Password Error" will be displayed. Press the [Esc] key to return to the previous menu.

8.7 Prompt and alarm information

In the process of user operation or system operation will pop up some hints and alarm information, such as reset, water protection failure, hard limit protection, border crossing and so on.

- Prompt

The system pop-up "The system is resetting.". show as below:

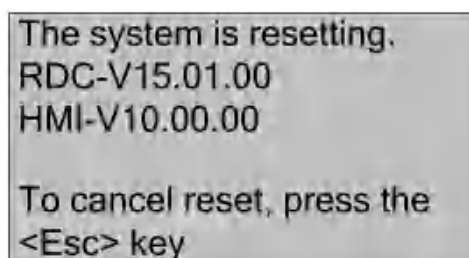

Figure 8-47 System Reset Info graphic

The user operates according to the interface prompts.

- Alarm Information

The system generates “water protection fault”, show as below:

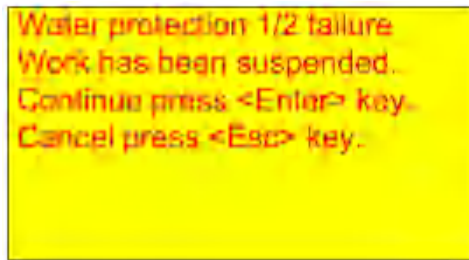

Figure 8-48 Water Protection Alarm Infographic

- 9 At this point, the system performs related operations according to the **<Enter>** or **<Esc>** keys.

Section 9 Auto Focus

CONTENTS:

- Auto Focus

9.1 Auto Focus

Press the <Focus> key when the screen is on the main interface,

Section 10

Manufacturer/User Parameters Introduction

CONTENTS:

- Manufacturer Parameters

10.1 Manufacturer Parameters

(1) Motor parameters

X/Y/Z/U axle parameters

- **Direction Polarity:** Modification of direction polarity can move the motor to the opposite direction. The modification purpose can move this axle to the origin on resetting. If this axle moves far from the origin on resetting, it means the direction polarity of this axle is wrong in setting and should be modified.
- **Spacing Polarity:** it is used to set the high and low level mode of spacing signal. When the motion axle arrives at the spacing position and input a low-level signal to the mainboard, the spacing polarity at this time should be set to be minus.
- **scope:** it means the farthest distance that the motion axle can move, which is determined in accordance with the actual condition of the machine.
- **Distance from Origin to Hard Spacing:** if this axle enables hard-spacing protection, generally this value should be set to be 2~5mm; if it is set to be 0, when this motion axle moves to the smallest coordinate, i.e. 0, this spacing may be validate, which may wrongly triggers the hard-spacing protection and scam the machine. If the hard-spacing protection is not enabled, this value can be set to be 0~5mm.
- **Control Mode:** Double pulse or direction+single pulse are optional, in general, direction+single pulse is selected.
- **Motor Stepping:** it means the impulse equivalent, the absolute distance gone by the corresponding motion axle when a pulse is delivered to the motor. Prior to the correct setting of this value, a large rectangle can be cut with the machine (the larger the figure is, the smaller the difference is). The motor stepping can automatically be calculated according to the figure length and measuring length.
- **Hard-spacing Protection:** it is used for whether the hard-spacing protection of this axle is enabled.
- **PWM Rising edge valid :** To set the motor driver's pulse signal rising edge valid or falling edge valid. If this item is disabled, the pulse is falling edge valid, or, it's rising edge valid.
- **Reset Enable:** if the machine is provided with this axle, its "Reset Enable" should be opened; if no, its "Reset Enable" should be prohibited.
- **Takeoff Speed:** it means the speed of the motion axle in direct start from the

idle condition. If this value is excessively large, it will make the motor lose steps, jar and even squeak; if small, it will reduce the running speed of the whole figure. If the inertia of the motion axle is larger (the axle is heavier), you can set a smaller takeoff speed; if smaller (the axle is lighter), you can increase the takeoff speed. For example, the typical value is 5~30mm/s.

➤ **Maximum Speed:** it means the maximum limit of motion speed that this axle can bear. This parameter has something to do with the driving force of motor, the inertia of motion axle and its drive ratio. For example, the typical value is 200~500mm/s.

➤ **Maximum Acceleration:** it means the maximum acceleration of the motion axle in accelerated or decelerated motion. If the acceleration is set too large, it will make the motor lose steps, jar and even squeak; if too small, it will cause the reduction of acceleration so as to reduce the running speed of the whole figure. For the axles with larger inertia, such as Y axle corresponding to the beam, its typical setting range is 800~3000mm/s²; for the axles with smaller inertia, such as X axle corresponding to the car, its typical setting range is 8000~20000mm/s².

➤ **Scram Acceleration:** if this axle enables the hard-spacing protection, when this axle moves to the spacing position, it will scam operation at the scam acceleration. This value can be 2~3 times of the maximum acceleration for this axle.

Key parameters

➤ **Key Move Takeoff Speed:** it means the starting speed to move this axle by way of the keys on the keyboard, which can't be higher than the takeoff speed.

➤ **Key Move Acceleration:** it means the acceleration to move this axle by way of the keys on the keyboard, which can't be higher than the maximum acceleration of this axle.

➤ **Key Polarity:** it is used to control the movement direction of the axle that is moved through manual operation of the keys. After the direction polarity is correctly set, if you press the directional keys on the operating panel, this axle will move to the opposite direction. In such a case the polarity of keys should be modified.

(2) Laser parameters

➤ **Laser Configuration:** single laser and double lasers are available for option

and set in accordance with the laser-tube quantity provided by the manufacturer.

- **Laser Type:** glass tube, RF laser (not need pre-ignition pulse) and RF laser (needing pre-ignition pulse) available for option.
- **Laser Attenuation Quotient**
- **Laser Enable:** When double lasers are used, then each laser can be respectively enabled or disabled.
- **Minimum Power**
- **Maximum Power**
- **Laser PWM Frequency**
- **Pre-generation Frequency**
- **Pre-generation pulse scale:** When the laser is RF-laser and it's need to pre-generate PWM, then set the Pre-generation Frequency and the Pre-generation pulse scale.
- **Water Protector Enabled:** When the water protector is enabled, the mainboard will detect the input port of water protector. If this port is of low level, it will be deemed normal; if this port is of high level, the mainboard will forcibly close the laser to suspend the work in progress and the system will warn. If the water protector is not enabled, the mainboard will not detect the input port of water protector and so the water protector can be unconnected.

Laser PWM Frequency is used to set the pulse frequency of control signal used by this laser, in general, glass tube is about 20KHZ, RF laser is about 5KHZ; the maximum/minimum power (%) is used to set the limit power of this laser, that is to say, during the operation, the maximum power set by the user can't be higher than that set here and the minimum power set by the user can't be less than that set here, either. When a laser's power is attenuated, then the laser attenuation quotient may be set

The laser frequency is used to set the pulse frequency of the control signal used by the laser, the glass tube is generally set to about 20KHZ, and the RF tube is generally about 5KHZ; The maximum/minimum power (%) is used to set the limit power value of the laser, that is, during operation, the maximum power set by the user cannot be higher than the maximum power value set here, and the minimum power value set by the user cannot be lower than the minimum power value set here; If the power of the laser is attenuated after a period of use, the laser power can be fine-tuned by setting the laser attenuation coefficient, and the attenuation

coefficient is 0 when it is not attenuated.

	If only a single laser tube is configured, only one laser parameter is displayed.
---	---

3) Other manufacturer parameters

Machine configuration

- **Machine Type:** In most cases, the general engraving machine should be selected and other types used for specific purposes.
- **Transmission Mode:** generally the “Belt Stepping Type” should be made choice of. The control algorithm will be changed a little when other types are selected.
- **Feeding Mode:** it has single-way mode and two-way mode for option. If it is of single-way feeding, it is unnecessary to check the coordinates. Feeding can be conducted in the single-way mode; if it is of two-way feeding, the system will check the maximum and minimum coordinates. The odd sequence means feeding should be done to one direction and the even sequence means feeding done to the other direction. The initial direction for the first time can be changed through setting the directional polarity or modifying the plus and minus values of the feeding length.
- **Power-Off-Restart Delay:** it can be set to be 0~3000ms. After the power-off of the electricity grid, the power supply of the system will not drop to 0 at once. There is a delay during this time. The delay value set here should basically consistent with the actual off-delay value. If the deviation of set value is larger, on the de-energizing for continuous engraving, either the figure processed for the second time is not closed with that before the cutoff, or it is coincided with that too much.

 Prompt	After the configuration parameters in the manufacturer parameters, such as directional polarity, control mode, laser type and laser PWM frequency, are modified, the system should be reset. Such a modification can function upon the resetting of the system.
---	---

Enable parameters

- **Door Opening Protection:** If this item is enabled, then the door opening protection must be connected to the controller, or, the machine will not run.
- **Whether to enable the blower:** If using wind out port to control the blower by the graph layer parameter, this item must be enabled, or, the wind output is a signal for other using.

10.2 User parameters

(1) Cutting parameters(Only affect cutting arts)

- **Idle Move Speed:** this parameter decides the highest speed of all non-lighting lines for the machine in the movement process.
- **Idle Move Acceleration:** it means the highest acceleration of all non-lighting lines. Idle stroke speed and idle stroke acceleration can be set higher to reduce the working time of the whole figure, but if they are set too high, it may cause the jarring of track, so comprehensive consideration should be given to the setting.
- **Idle Move Delay:** If this parameter is zero, then after idle moving there is no delay, or, there is delay and the speed will decrease to turn off speed.
- **Turning Speed:** it means the speed of turning at the acute-angle corner, which is also the highest speed in the whole cutting process.
- **Turning Acceleration:** it means the acceleration of turning at the acute-angle corner when cutting. If the two speeds are set too high, jarring will happen to the turning; if set too low, it will influence the cutting speed. This acceleration is the least value of the whole graph.
- **Cutting Acceleration:** it means the highest acceleration value in the whole cutting process.
- **Acc Factor:** This parameter indicates how speedy the cutting acceleration is changing.
- **G0 Acc Factor:** This parameter indicates how speedy the idle move acceleration is changing.
- **Speed Factor:** This parameter indicates the cutting speed of the arc of various curvatures.

● **Key Setting:** This is a button but not a parameter, this button is used to recommend some experiential cutting parameters.

(2) Scanning parameters(Only affect scanning arts)

- **X-axle Starting Speed**
- **Y-axle Starting Speed**
- **X-axle Acceleration**

➤ **Y-axle Acceleration**

The above four parameters are used to set the starting speed and acceleration of two axes on the scanning. The higher the two speeds are, the quicker the scanning is.

➤ **Scanning Line-feed Speed:** this parameter is specially used to control the highest speed at which that the previous line vertically moves to the next line in the scanning mode. If the space between lines is larger during the scanning or if the distance of each block is larger during the scanning and deblocking of figure, it is necessary to position each line or block accurately. In such a case the speed of scanning line-feed can be set as a lower value.

➤ **Scanning Mode:** it is divided into general mode and special mode for option. If special mode is selected, the laser power should be increased. The smaller the speckle percentage is, the more the laser power reduces. The laser power to set should be larger in order to reach the same scanning depth. The purpose to select the special mode is to make the laser light at high power and short time. On the depth scanning the effect that the bottom is flatter is obtained, but it should be noticeable that if the speckle adjustment is not appropriate, it can achieve this goal. If the high power remains short, the lighting mode will influence the life of the laser. The system will default the selection of general mode.

➤ **Speckle Size:** When the general mode is selected as the scanning mode, this parameter will become ineffective; when the special mode is selected, this parameter will become effective. The controller will control this parameter among 50%~99%.



	The cutting and scanning parameters can't exceed the limited ones in the axle parameters. If so, the setting will become ineffective and the system will automatically cover the parameters with the axle parameters.
--	---

(3) Feeding parameters

➤ **Before-feeding Time Lag:** settable at 0~300s. The lagged time can facilitate user's feeding and picking on the feeding device.

➤ **After-feeding Time Lag:** settable at 0~9.9s. It can facilitate the feeding device's delaying in jarring after moving to the correct position and waiting for the 2nd work after the feeding axle stands still completely.

➤ **Progressive feeding:** If this item is enabled, then the dummy array graph on Y direction will run in the same position, running one line graph, the U axes moving one

time to feed, the moving length of U axes is the interval of the two lines graph on Y direction.

➤ **Progressive feeding repay:** Because of the imprecision of U axes' moving, there can set a value to repay the interval of the two lines graph on Y direction.

(4) Reset parameters

- **Reset Speed:** it means the speed of X/Y-axle linkage reset to the origin.
- **X axle start-up reset(Auto home)**
- **Y axle start-up reset(Auto home)**
- **Z axle start-up reset(Auto home)**
- **U axle start-up reset(Auto home)**

You can select "Yes" or "No" in the field of the above four parameters, which is used to confirm whether each axle can be reset on the startup.

(4) Go scale parameters

➤ **Go scale Mode:** "Blanked Bordering" means idling to start border preview; "Outputted Border Cutting" can manually cut off the well-processed figure; "4-corner Dotting" means to emit the light at four corner points of the frame to make a point and turn off light. The size and position of this figure can be checked intuitively through the four points. The bordering speed is the speed value set on the keyboard when the system is idle. For light output, its minimum/maximum power is the corresponding value set on the keyboard when the system is idle (The lasering power on the 4-corner dotting means the well-set maximum power).

➤ **Go scale Blank:** It means whether to extend a certain length outside the actual frame of the figure on the preview/cutting of frame.

	If the frame crosses the border, the interface will prompt it. If the Enter key is pressed at this time, the system will cut the border at the maximum/minimum coordinates first, and then border the figure. This bordering can be given up.
---	---

(5) Other user parameters

➤ **Array Mode:** Two-way array or one-way array can be selected. Two-way array means the to-and-fro cutting of array in sequence; one-way array means the cutting of array from one direction to another. On selecting one-way array, the elements of each array are the same in action mode and completely uniform in action fluency, which takes a little more time than two-way array. Two-way array is the default option.

- **Back Position:** The origin (the relative origin) and the machine's absolute origin can be selected. This parameter decides the parking position of laser head after each work.
- **Focus Setting:** it means the distance from the focal point of laser head lens to Z-axis origin. When there is no automatic focusing function, this parameter becomes invalid.
- **Material thickness:** Thickness of the object to be processed.
- **Non-contact focusing:** When YES is selected, the focus mode is non-contact focus, otherwise it is contact focus mode. This parameter defaults to contact focus mode.

The above three parameters are used to set the auto focus function. The auto focus mode can be divided into two modes: contact focus and non-contact focus. Each mode is divided into two modes. The autofocus function is done by the D axis.

Contact focus:

Mode 1: The D-axis directly drives the laser head to move downward until the laser head touches the surface of the material. At this time, the controller considers the position to be the origin position of the D-axis, and then the D-axis moves to the opposite direction by a certain distance. The distance is the focal length value in the parameter settings. In this mode, the material thickness parameter is invalid.

Mode 2: The D-axis drive platform moves upward until the material touches the laser head. At this time, the controller considers the position to be the origin position of the D-axis, and then the D-axis moves to the opposite direction by a certain distance, which is the parameter. The focus value in the settings. In this mode, the material thickness parameter is invalid.

Non-contact focus:

Mode 1: The D-axis directly drives the laser head to move upward until the laser head touches the limit switch placed at the top. At this time, the controller considers the position to be the origin position of the D-axis, and then the D-axis moves in the opposite direction. A certain distance, which is the maximum stroke of the D axis (the distance from the origin of the D axis to the plane of the machine plane) minus the sum of the focal length value and the material thickness value in the parameter setting.

Mode 2: The D-axis drive platform moves downward until the platform touches the limit switch placed at the bottom end. At this time, the controller considers the position to be the origin position of the D-axis, and then the D-axis moves to the opposite direction by a certain distance, the distance is The maximum stroke of the D axis (the distance from the origin of the D axis to the

plane of the machine that touches the laser head) is the sum of the focal length value and the material thickness value in the parameter settings.

- **Backlash X:** The X axes' backlash, accurate to 1um.
- **Backlash Y:** The Y axes' backlash, accurate to 1um.

Section 11 Communication

CONTENTS:

- Overview
- USB communication

11.1 Overview

The control system supports USB, wired network, WIFI three communication modes, can be with PC software RDWorksV8, Mantisolo (mobile app, Ruida Huikong), MantiSurf (Ruida WEB application software platform). The main communication methods of the motherboard are USB, wired network, and WIFI, but there are many combinations in combination with actual use, first introduce the specific application of these three communication methods separately, and then introduce the commonly used combinations in the 10.5 summary. Users can use the combination in 10.5 directly, or they can use different communication methods according to the actual situation.

11.2 USB communication

11.2.1 USB Driver installation

If the computer is installed with wind10 or above, you do not need to install the driver, you can ignore this section. The following takes Wind7 as an example to describe the detailed steps of USB driver installation.

Connect the board to the computer with a USB cable, and open the computer device manager. Find the computer icon on the desktop of your computer, then right-click and select it among the options that pop up<Management>.

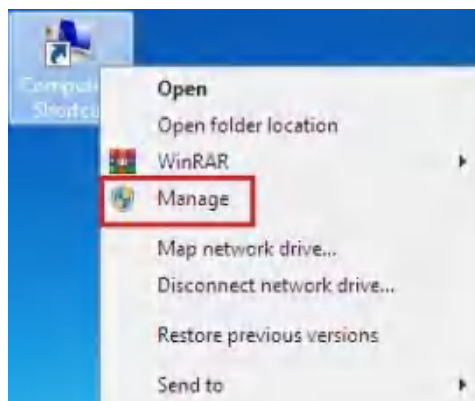

- Select it in the pop-up interface <device management>and check <other device>whether there is a device with a yellow exclamation mark. As shown in the figure below, if it exists, it proves that the USB hardware of the motherboard is normal, otherwise you need to check whether the USB cable is connected incorrectly.

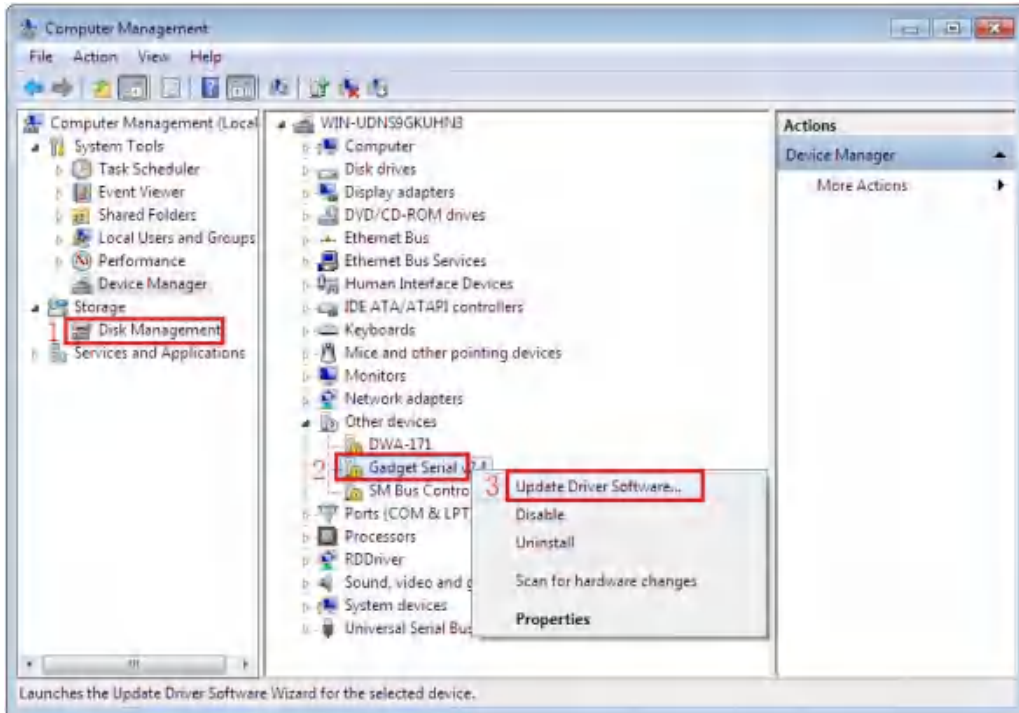

- Select the yellow unknown device and right-click to select . <Update the driver software >

- In the pop-up screen, select <Browse the calculator to find the driver software>.

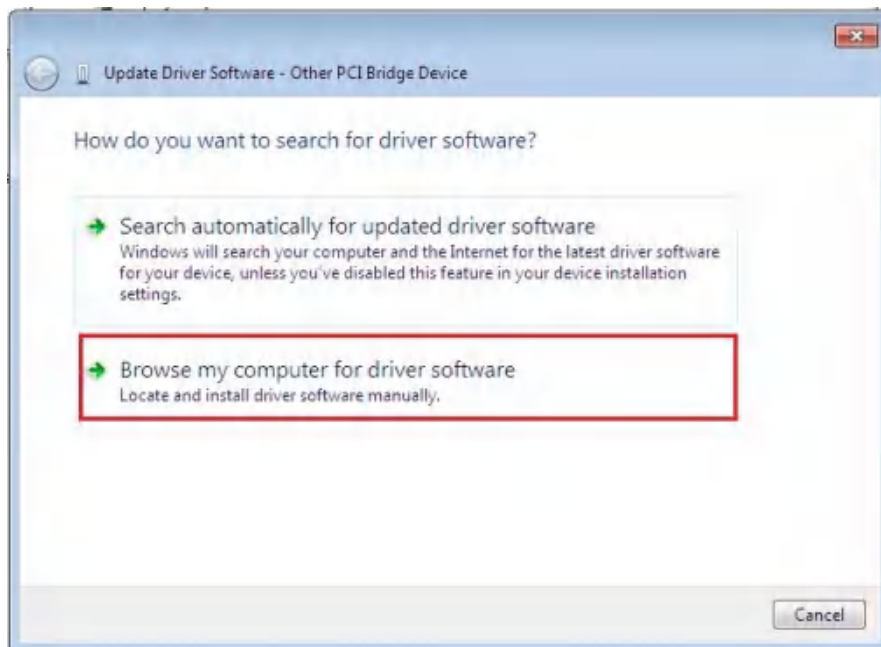

- Driver installation. <gadgetserial>Please download the driver file from the official website. rial>

- 1) Click to browse

- 2) Locate the folder where the startup files are placed

- 3) Click to Confirm
- 4) Click Next

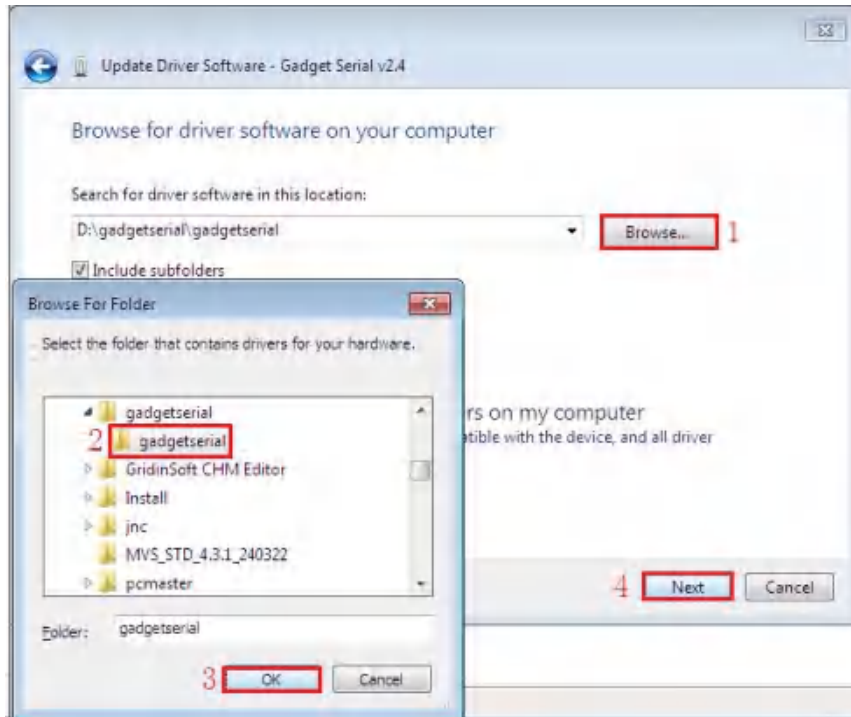

- If prompted, select Always install this driver software



● The installation is complete. Wait for the installation to complete and then close the installation completion prompt, then back to Device Manager. As shown in the figure below, the Gadget Serial (COM10) device appears in the port, which means that the installation is successful, and the specific COM port will vary according to different computers and different USB ports.

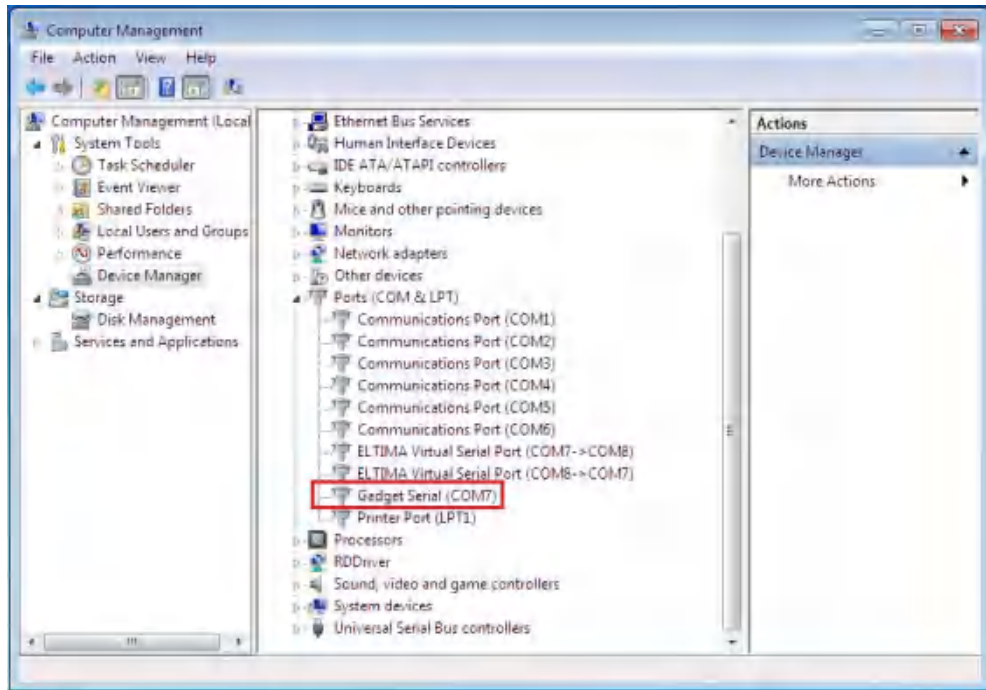

11.2.2 USB communication with software

USB can be used to communicate with PC software RDWorksV8, which has the characteristics of fast and stable communication speed. Connecting with PC software is divided into the following steps:

1. Connect the board to the computer with a USB cable,
2. Open the RDWorksV8 software and perform the following operation, and the final prompt is successful, indicating that the software communicates successfully with the mainboard.

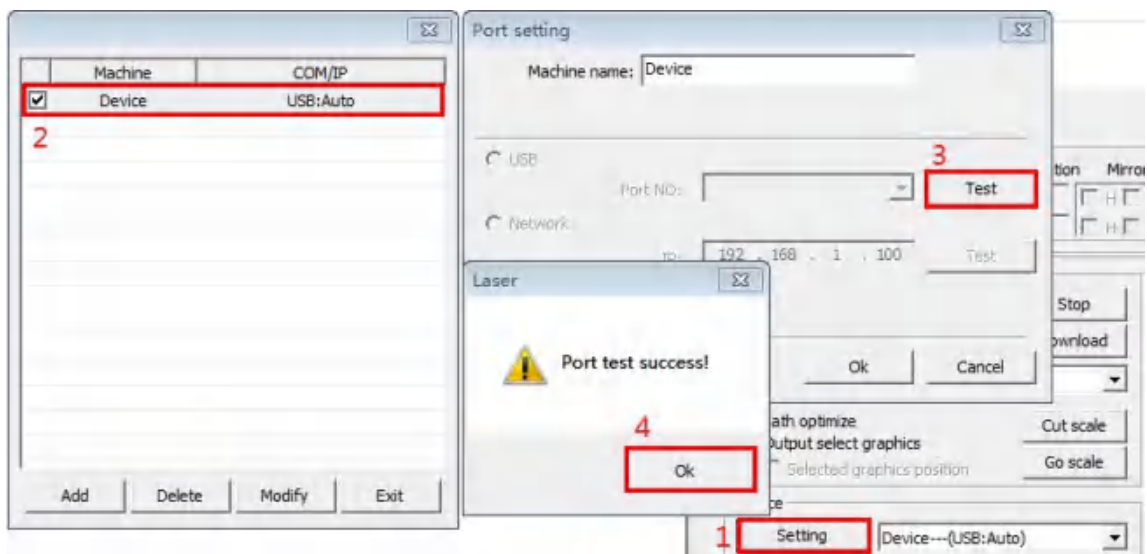

11.3 Wired Network Communication <Ethernet Cable>

Wired networks can be set to both auto/manual modes.

In automatic mode, user must connect the board and the router with a network cable, so that the router can automatically assign an IP to the board. If the router can access the Internet, the mainboard will be able to access the Internet after automatically obtaining the IP, mainly to communicate with the WEB application software, mobile app, etc.

In manual mode, user need to manually set the IP address, and connect the board and router with a network cable, or connect the mainboard and computer with a network cable. In this mode, it can communicate with RDWorksV8 and mobile apps, but it is not possible to communicate with the web software because it cannot access the Internet.

11.3.1 Communication with RDWorksV8 over a wired network

- (1) Manually set the IP address of the mainboard
- (2) Configure via the control panel using this path: Menu → Controller Settings → Network Settings → Wired Network Settings+
- (3) Select "Manual" in the interface, then set your IP address (e.g., 192.168.1.100).

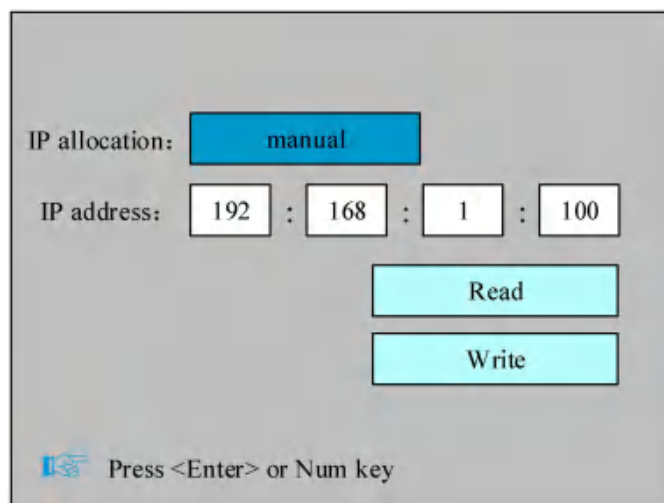

After setting, open the software to communicate with RDWorksV8, the specific operation steps are shown below. If the test is successful, it means that the software communicates successfully with the mainboard, otherwise need to check whether the IP address of the computer and the IP address of the mainboard are not in the same network segment.

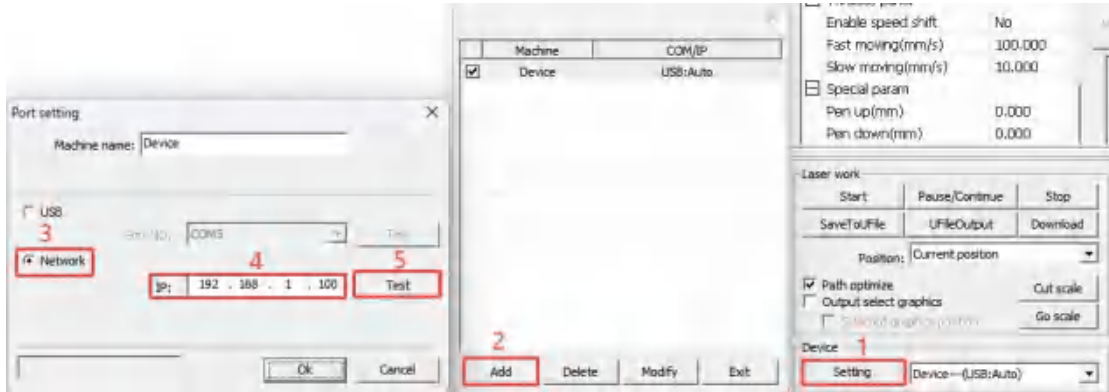

(2) Automatically obtain IP addresses

In this mode, user need to connect the mainboard to the router with a network cable, and also need to connect the computer to the same local area network.

Configure via <menu--> the panel Controller Settings----> Network Settings----->Wired Network Settings+> and select on the screen<auto>. In this mode, there is no need to set the IP, after clicking "Write Parameters", the router will automatically assign an IP to the motherboard, and check whether there is an IP through "Read Parameters", if so, it means that the assignment is successful.

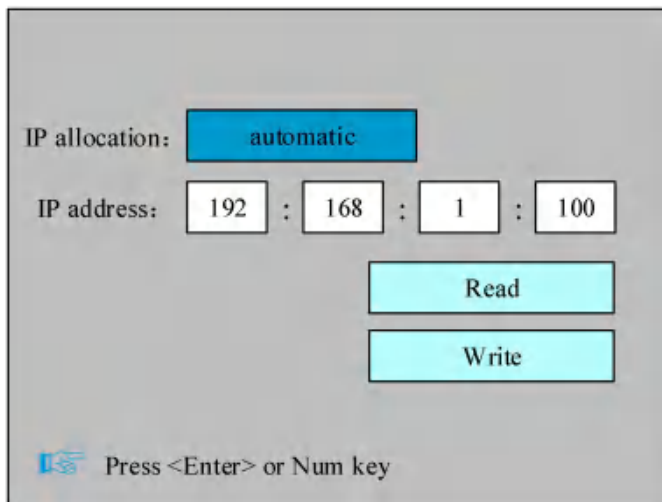

In this mode, it is also necessary to ensure that the IP of the computer and the IP of the mainboard are in the same network segment, so user need to connect the computer to the same LAN as the mainboard, such as connecting the network cable to the same router, or connecting the computer to the WIFI sent by the router. Again, the connection of the software and the

mainboard is tested in the same way.

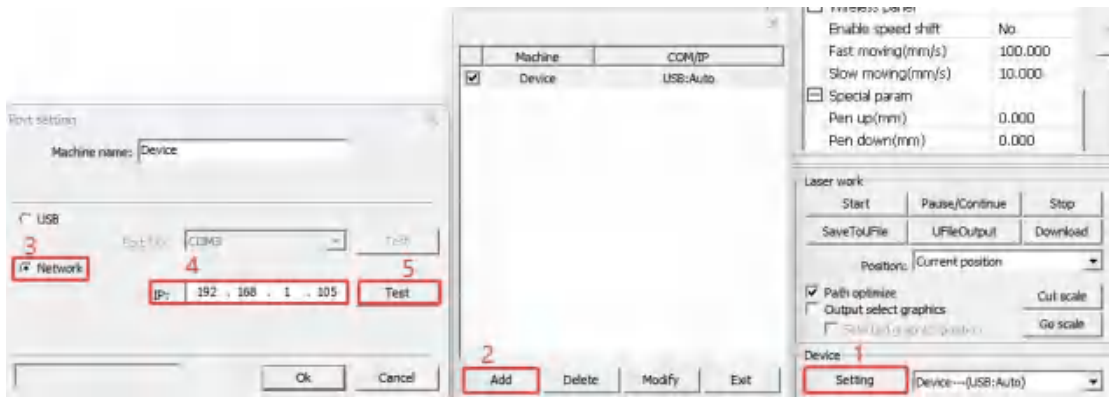

11.3.2 The software is used via a wired network connection to the WEB

In order to use the wired network to communicate with the web application software, it must be set to automatic mode, and the router connected to it must be able to access the Internet, and only if it can access the Internet can the data be sent to the web page and displayed.

See Section 8.6.4.5 for the web application software configuration process. First, user need to enable IOT, and then select the server, which is currently available in Asia/Europe/America, and users need to set it according to the actual situation, otherwise the communication may be unstable.

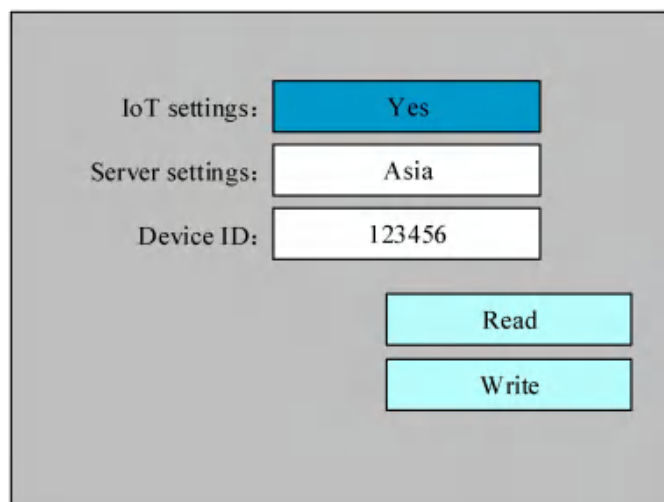

11.3.3 Communicate with the mobile app over wired network

When communicating with the APP, the mainboard must be connected to the router, and the mobile phone needs to be connected to the WIFI sent out on the router, that is, to ensure that the mobile phone and the board are in the same LAN. In this case, user can select Automatic or Manual IP assignment mode. For more information about the operation of the APP, see Chapter 12.

11.4 WIFI

WIFI communication is essentially the same as wired network communication, both are network communication, but WIFI does not need to be connected with a network cable. There are two modes of WIFI, one is AP mode and the other is STA mode.

In AP mode, the board sends out a hotspot for other devices to connect, similar to a mobile phone turning on a hotspot. In this mode, the board cannot access the Internet. In this mode, it can only communicate with the software RDWorksV8 on the computer and the mobile APP.

In STA mode, the mainboard connects to the hotspot sent by the router, mobile phone, or computer to achieve the function of surfing the Internet. In this mode, it is possible to communicate with web application software, mobile app, etc

11.4.1 Communicates with RDWorksV8 via WIFI

1) Communication with the software in AP mode

For details about how to set up AP mode, see Section 8.6.4.5. After setting the AP mode, the hotspot name generated by the board will be displayed in the "Name" list, and the computer/mobile phone can find the WIFI and connect it. In this mode, the IP address is fixed at 192.168.20.1

Mode: AP_5G

Name: RDC8445S001

Password:

IP address: 192 : 168 : 20 : 1

Read Write

Press <Shift> to open the lowercase letter soft keyboard

2) STA mode

For details about how to set up the STA mode, see Section 8.6.4.5. Set the mode to STA, then enter the wifi account name, and password, write the parameters after the setting is completed, the mainboard will connect to the wifi, after the connection is completed, it will prompt, and can assign an IP address to the mainboard, as long as the computer/mobile phone is in the same LAN< the computer and the mainboard are connected to the same router, or the mainboard is connected to the WIFI> sent by the computer, you can communicate, and the communication is consistent with the 10.3 wired network communication.

Mode: STA

Name: abc

Password: 123456

IP address: 192 : 168 : 101 : 38

Read Write

Press <Shift> to open the lowercase letter soft keyboard

11.4.2 Connect to the web via Wi-Fi and use the software

In order to communicate with the web using software via Wi-Fi, it is necessary to set the STA mode, and only then user can access the Internet and send data to the web

page and display it. In addition, it is necessary to ensure that the connected WIFI can be connected to the Internet. For more information about STA mode, see 10.4.1. As long as the connected WIFI can access the Internet and the signal is good, and the IOT function is enabled, you can connect to the WEB.

11.4.3 Communicate with APP via WIFI

In both STA and AP modes, it can communicate with the mobile app. In STA mode, as long as the mobile phone and the board are connected to the WIFI sent by the same router or the mainboard is connected to the WIFI sent by the mobile phone, then you can get the displayed IP address in the WIFI setting interface for communication. In AP mode, the mobile phone needs to connect to the hotspot sent by the board and communicate through the IP address 192.168.20.1.

11.5 A summary of common connection methods

Before delivery, the wired network is set to manual mode by default, and the IP is 192.168.1.100 by default; The wifi is set to STA mode, and the user can change the wifi account and password after receiving it. The following is only a list of common combinations, and users can combine them according to the actual situation and the above chapters.

11.5.1 WEB

(1) **Communication connection mode with RDWorksV8:**

- Method 1, the mainboard communicates directly with the software through USB, and the software communicates directly through the USB port;
- Method 2: Connect the mainboard and computer directly with a network cable. On the <Wired network communication>screen, set the mode to <manual>and set the IP address to the same network segment as the computer, or set the mode to<Auto>. The computer software connects to the IP address to realize RDWorksV8 communication.
- Method 3: Use WIFI to connect the mainboard and computer. When the <WiFi>interface is set to AP mode, the computer is connected to the mainboard hotspot, and the software is connected to the IP address "192.168.20.1" for communication; Or <WiFi>set the interface to STA mode,

the computer and the mainboard are connected to the same WIFI, and the software is connected to the corresponding IP address for communication.

(2) Connect with mobile APP::

➤ Method 1: Set the WIFI mode of the mainboard to AP mode, and connect the mobile phone to the hotspot of the mainboard to achieve APP communication.

➤ Method 2: Connect the mainboard to the router via a network cable. The mobile phone is connected to the hotspot sent by the router to realize APP communication.

For more information, see the previous section.

11.5.2 Required WEB Application Software Functions

(1) Connect the mainboard to the router using a network cable

Communication connection method with WEB application software: In the <Wired Network Communication> interface, set the mode to <Automatic>, and connect to the corresponding IP address for communication.

Communication connection methods with RDWorksV8 software:

Method 1: In the <Wired Network Communication> interface, set the mode to <Automatic>, and connect to the corresponding IP address for communication;

Method 2: Connect the computer to the motherboard via USB cable, and the software communicates directly through the COM port.

● Communication connection methods with mobile APP:

Method 1: Set to AP mode in the <WiFi Communication> interface, connect the phone to the mainboard's hotspot, and connect to the corresponding device IP address in the APP to establish communication;

Method 2: Set to STA mode in the <WiFi Communication> interface, connect both phone and mainboard to the same WiFi network, and connect to the corresponding device IP address in the APP to establish communication;

Method 3: Connect the phone to the router's hotspot, and connect to the corresponding device IP address in the APP to establish communication.

Not connecting the mainboard to the router with a network cable.

Communication connection method with WEB application software:

In the <WiFi Communication> interface, set to STA mode, connect both computer and mainboard to the same WiFi network, and connect to the corresponding IP address for communication.

Communication connection methods with RDWorksV8 software:

Method 1: In the <WiFi Communication> interface, set to STA mode, connect both computer and motherboard to the same WiFi network, and connect to the corresponding IP address for communication;

Method 2: Connect the computer to the motherboard via USB cable, and the software communicates directly through the COM port.

Communication connection method with mobile APP:

In the <WiFi Communication> interface, set to STA mode, connect both phone and mainboard to the same WiFi network, and connect to the corresponding device IP address in the APP to establish communication.

Users should configure settings according to their specific circumstances. For detailed setup instructions, please refer to the previous chapters.

11.6 Precautions

1.If IOT function, the control card must have internet access

When using WiFi in STA mode, connect to a WiFi hotspot with internet access. Alternatively, connect the mainboard to the router using a network cable, set the wired network to automatic mode, and ensure the connected router has internet access.

1.Do not use the IP address on the wired network or Wi-Fi connection mode to be on the same network segment

For example, if the wired network is set to automatic mode to connect to a router, and the Wi-Fi is set to STA mode to connect to the same router's Wi-Fi, or if the wired network is set to manual mode and the Wi-Fi is in STA mode, with both IP addresses in the same subnet, in this case, the wired network's IP and the STA mode IP must be manually set to be in different subnets.

Section 12

Instructions for mobile

APP

Download guide:

Android users can scan the QR code below through the browser to download the APP



IOS users can search for Mantisolo in the App Store or scan the QR code below in your browser to download the app:



Note: The registered email address can log in to both web and APP for RUIDA IoT products

When user first time to install:

According to the selection of the mode of the device, RDC8445S need to switch to laser cutting mode.

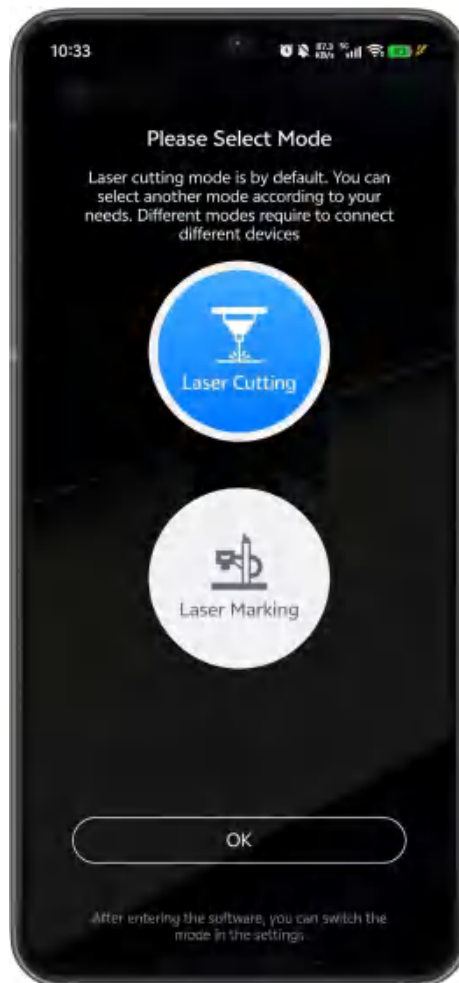

12.1 list of devices

Add and connect devices

This module mainly manages the connection between the APP and the device, which is one of the core functions of the APP. The mobile phone is connected to the wireless router through WiFi, and the device mainboard is connected to the LAN port of the wireless router through wired Ethernet (the device can also be configured with wifi to make the device connect to the wireless router through wifi), at this time, the mobile phone and the device mainboard are in the same LAN, and the Mantisolo APP and the mainboard can be communicate.

The following steps are performed to connect :

1. The phone is connected to a hotspot on the wireless router.

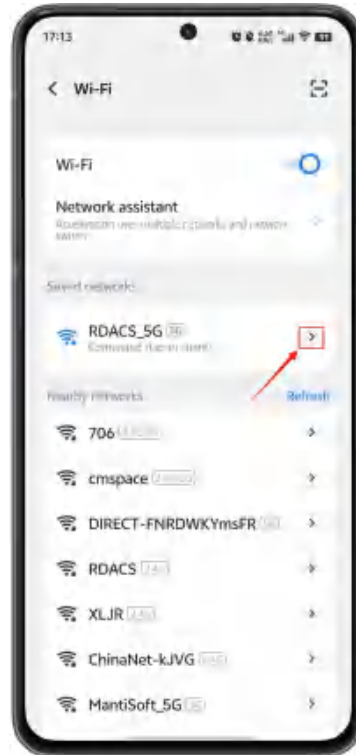

2. The mainboard is connected to the wireless router

From the control panel "menu--> controller settings--> network settings-->wifi settings" enter the same wifi name and password connected to the mobile phone, and then click the write parameter to connect to wifi, after the connection is successful, the panel will prompt and assign an IP to the mainboard. This is shown in the figure below:

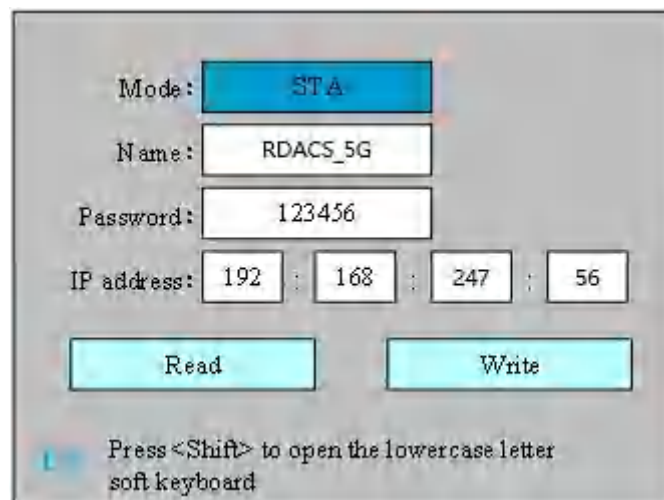

3. APP to add a device

Click the Add Device button, pop up the box and edit, and finally click OK to add it (the device name can be customized, and the IP address must be consistent with the IP setting of the control

panel you want to connect to, that is, 192.168.247.56).

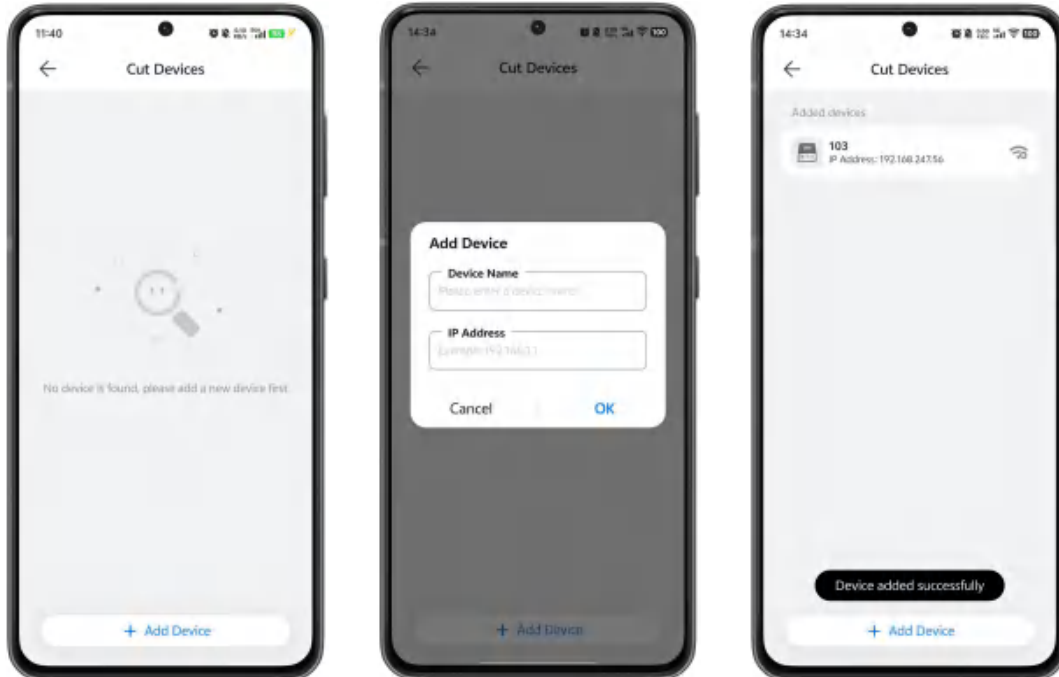

The addition was successful(Multiple devices can be added) as shown in the following figure:



Click on the device added device in the device list, there will be a pop-up window, it can view the device information and perform related operations, click the connection, after the prompt is successful, it means that the APP has established a connection with the mainboard.



At this point, the 103 device has been bound to the connected control panel. Connected devices can view the mainboard model and version number of the control panel, while unconnected devices cannot view it.

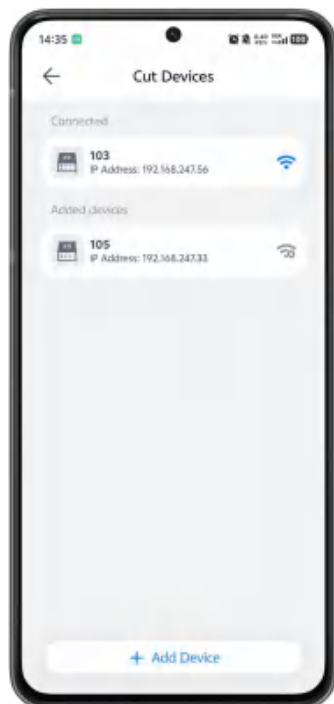

After the device is successfully connected, return to the home page, and the connected devices

will be displayed, at this time, the home page is as follows:

Note 1: The device is connected.

Note 2: Machining control button, click to jump to the machining control interface, this button will only be displayed when the device is connected.

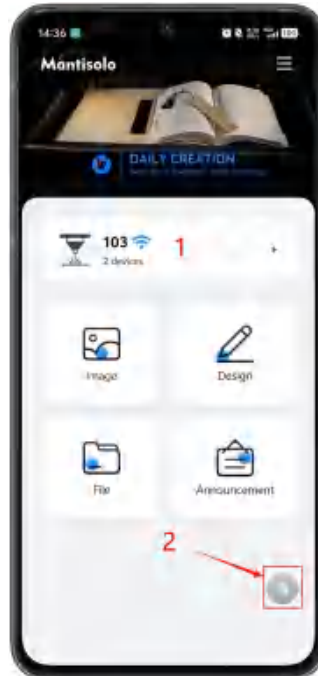

Cutting control: The machining control interface is as follows:

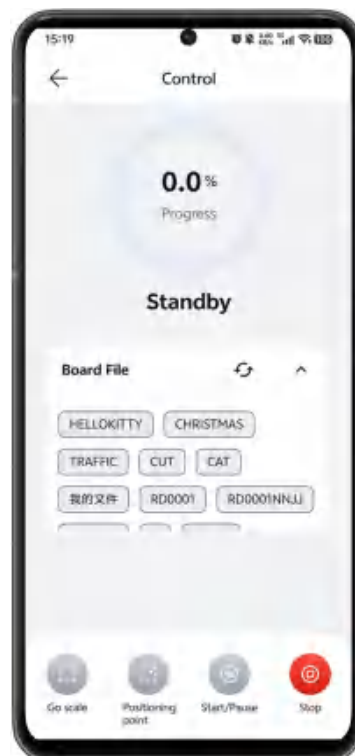

Frame: This feature will make the device move along the boundary of the selected Chinese piece.



Positioning point: it can click the anchor button and set specific coordinates to set the positioning point.

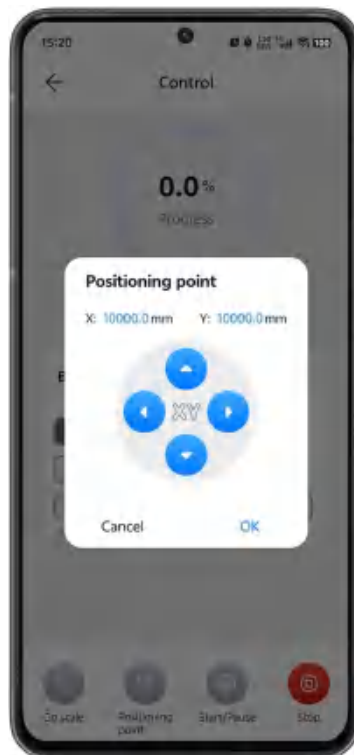

Start/Pause: Start/pause cutting.



Stop: After clicking the stop button, a pop-up box will appear to confirm the stop, and the machine will stop processing after confirmation.



12.2 Creation of processing files

This function is one of the core functions of this APP, it can create object files, save and load to the board, and start to operation.

Image Module:

it can design photos taken from photos taken or images selected from albums, which will be explained in the image mode in the authoring module.

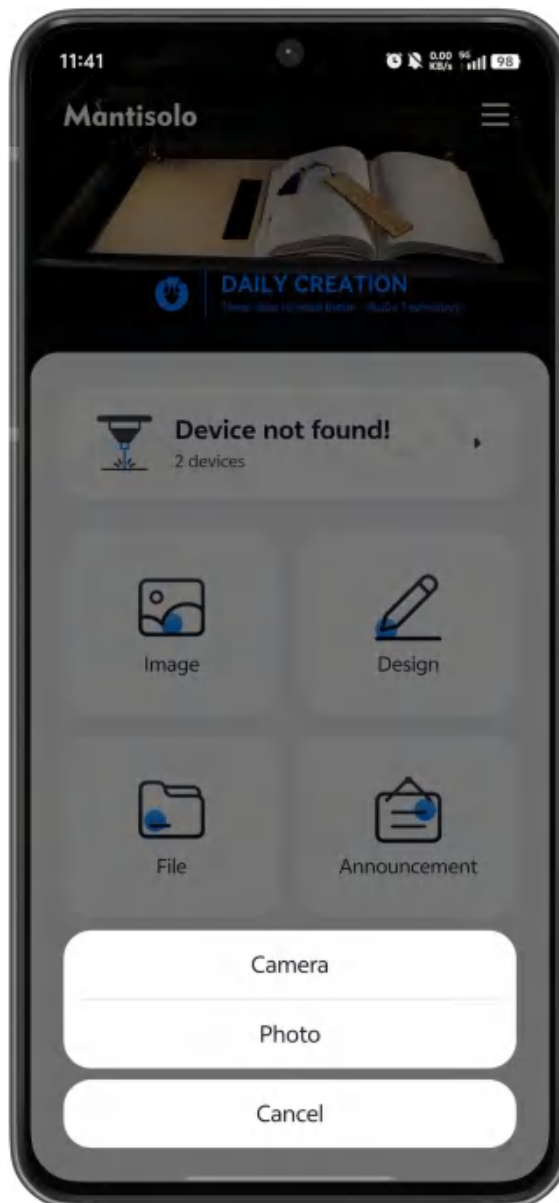

Creative Module:

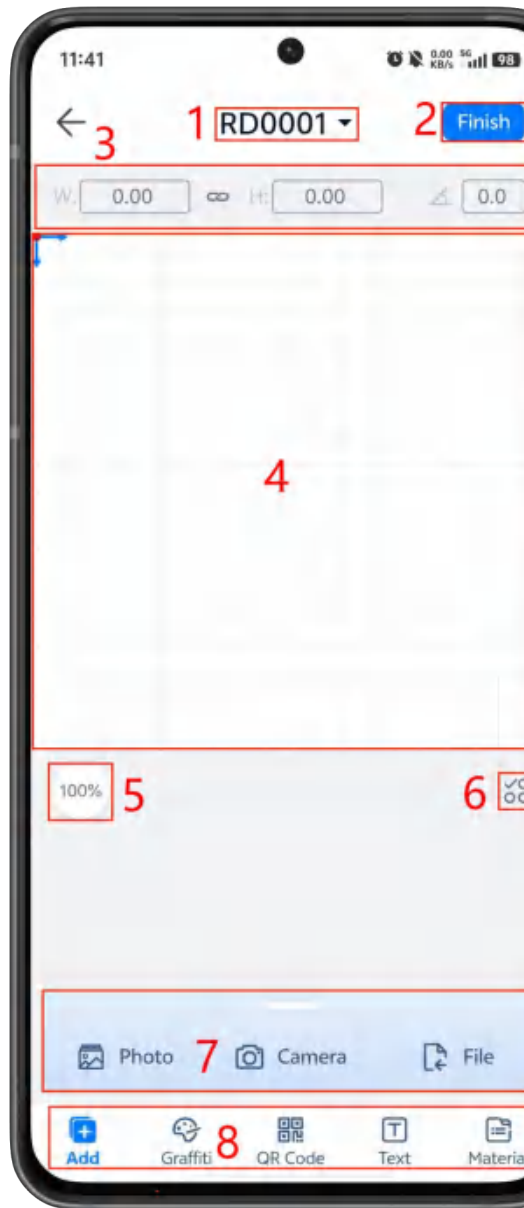

- 1: Default file name, each time create a file, there will be a default file name, which is incremented from RD0001 and can be changed after clicking.
- 2: After the creation is complete, click to proceed to the next step.
- 3: Display the width, height and rotation angle of the selected content respectively.
- 4: Canvas, display creative content, scalable, can hold multiple content
- 5: Adjust the canvas button
- 6: Box selection function, after clicking, multiple contents will be boxed and merged at the same time, and clicking again will cancel the box selection
- 7: The way to add image files to the canvas.
- 8: Generate content images onto canvas in 5 creative modes

Default file name revise:

Click the default file name to change it, if the prompt file name already exists, it means that the RD file with the same name has been saved in the file module.

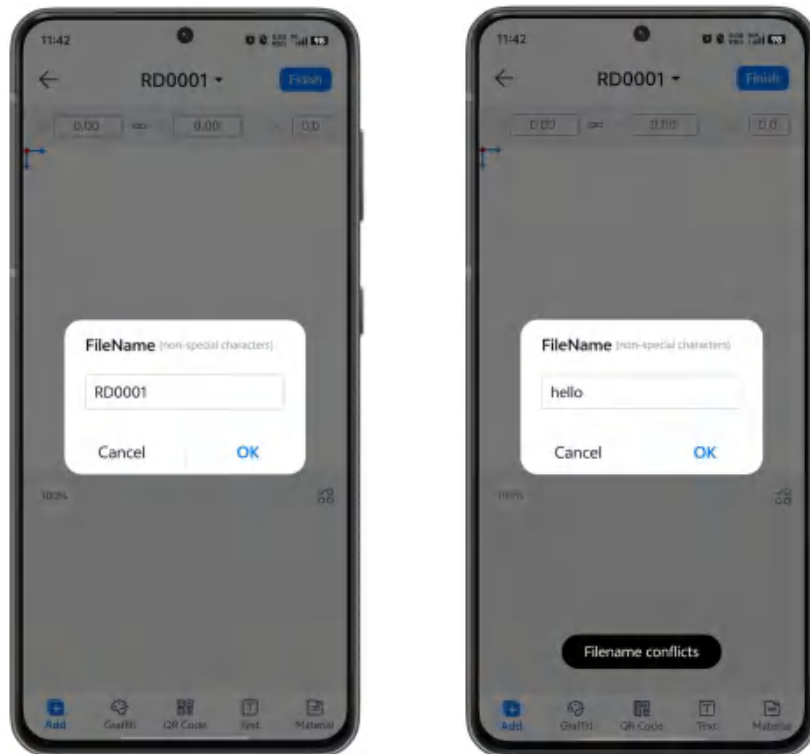

After the file name is successfully modified:



Canvas Adjustments:

Tap to select the appropriate canvas size, or pinch the canvas with two fingers to gesture to zoom to the desired proportion. When there is content on the canvas, select the appropriate content and it will be scaled adaptively; Hide the grid to hide the grid lines on the canvas.



Creation:

Add:

Album: You can click to select pictures, and when you need to grant relevant permissions from your phone, it is recommended to select Allow access to all

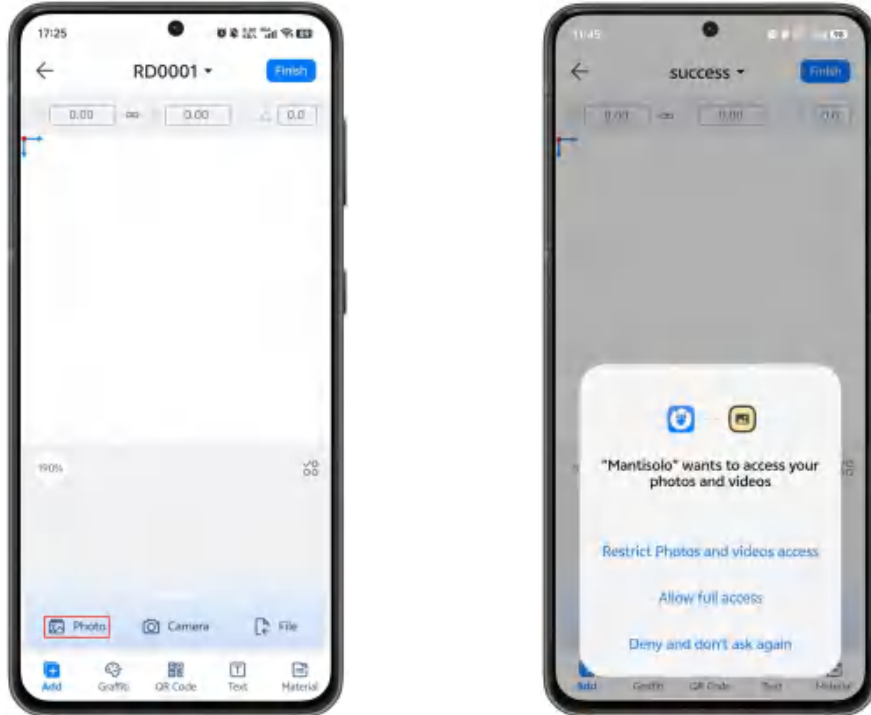

Take a photo: After clicking, the camera will be evoked to take a picture to get a picture, and this process requires the relevant permission of the mobile phone.

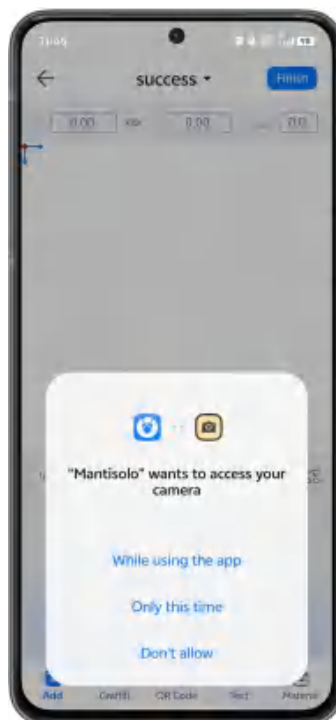

Files: Import files from your phone's storage for processing and creation, and only

support specific types of files.

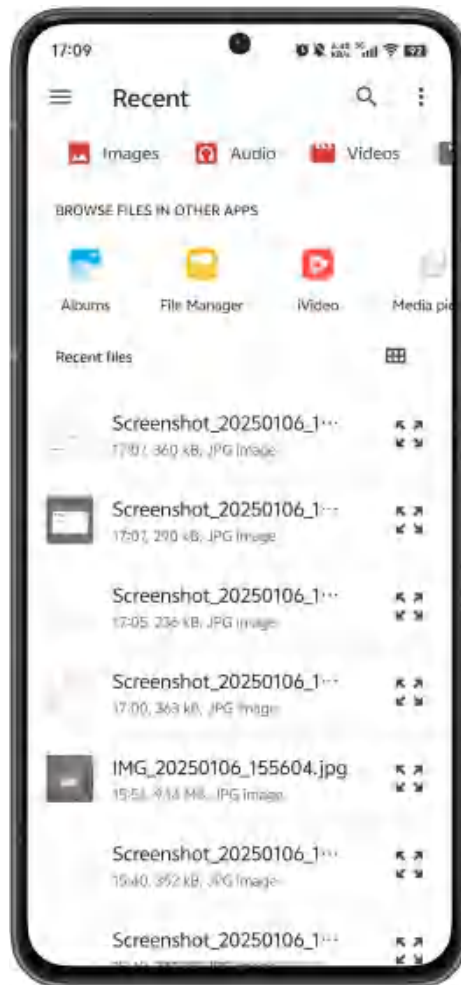



After the picture is successfully added to the canvas, it can be diffusion, black and white, jitter, and news printing operations.

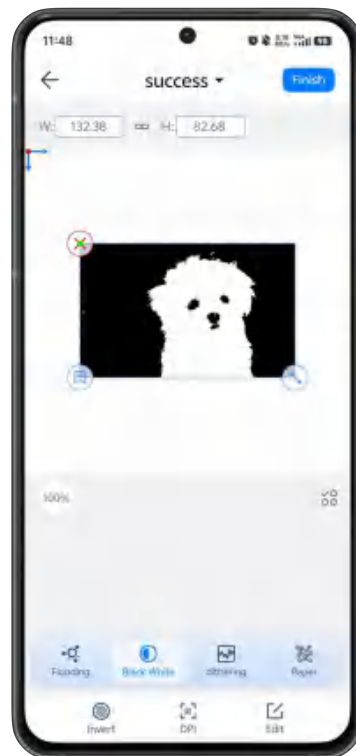
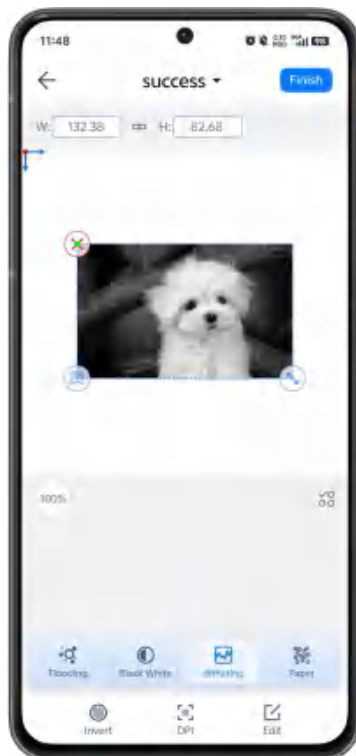
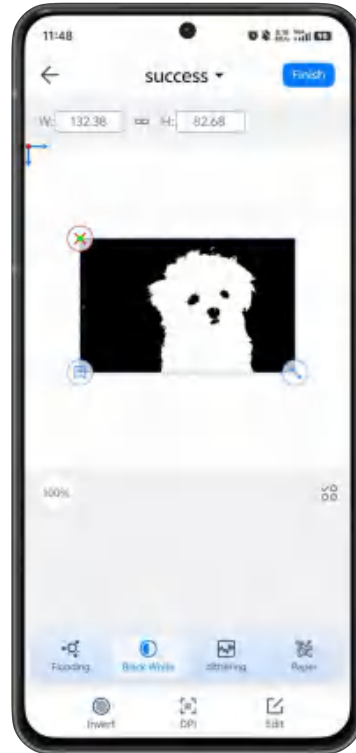
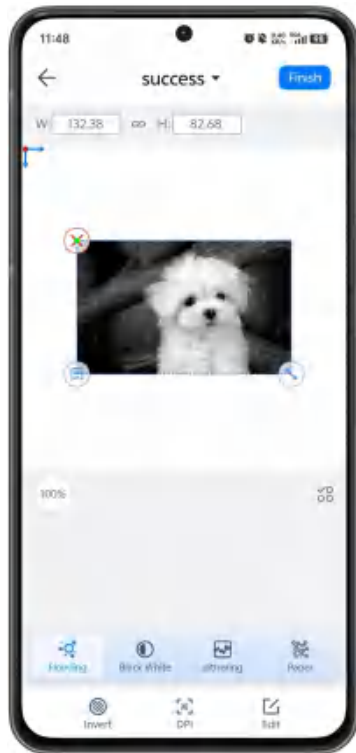

Combined with the negation operation, you can obtain more different effects.

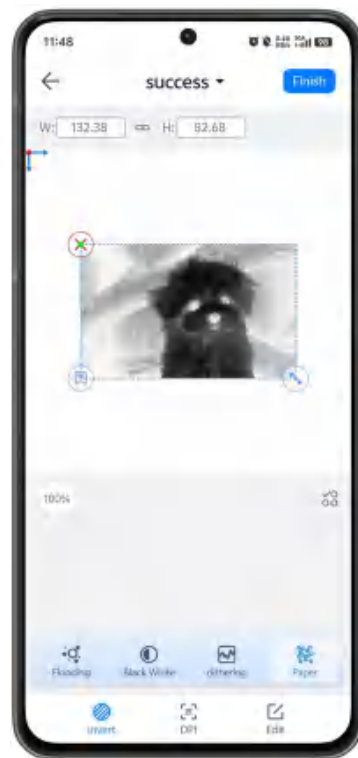

Click the DPI button to set the editing DPI (DPI indicates the number of pixels per inch of the length of the image, generally speaking, the higher the DPI value, the higher the printing accuracy of the image).

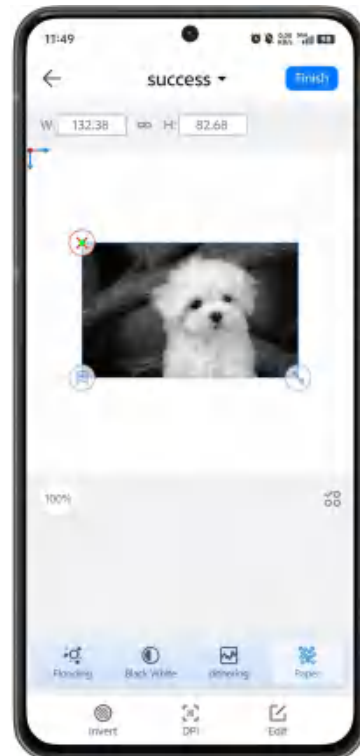
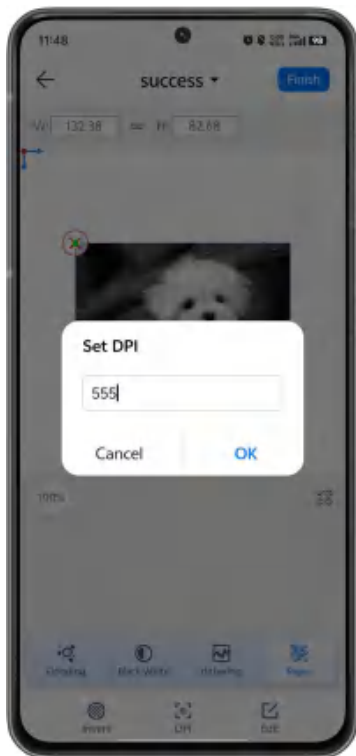

Edit: Click the Edit button to do more with the original image.

Cropping: You can select the cropping area and crop it as needed.

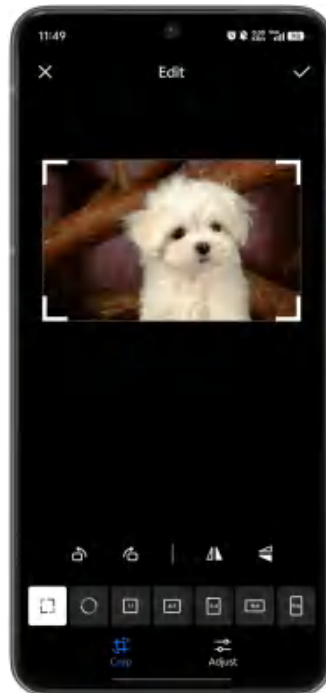

Pictures can be flipped and mirrored in editing:

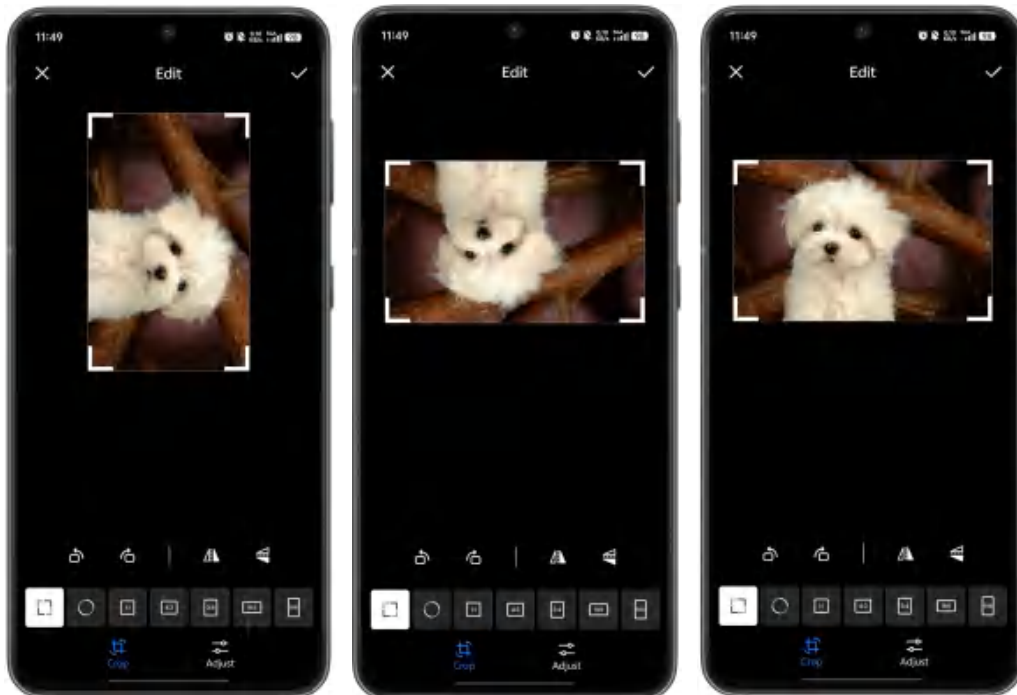

Adjustment: Adjust the brightness and contrast.

Brightness adjustment: Pull the brightness bar to adjust the brightness of the image.



Contrast adjustment: Pull the contrast bar to adjust the contrast of the image.

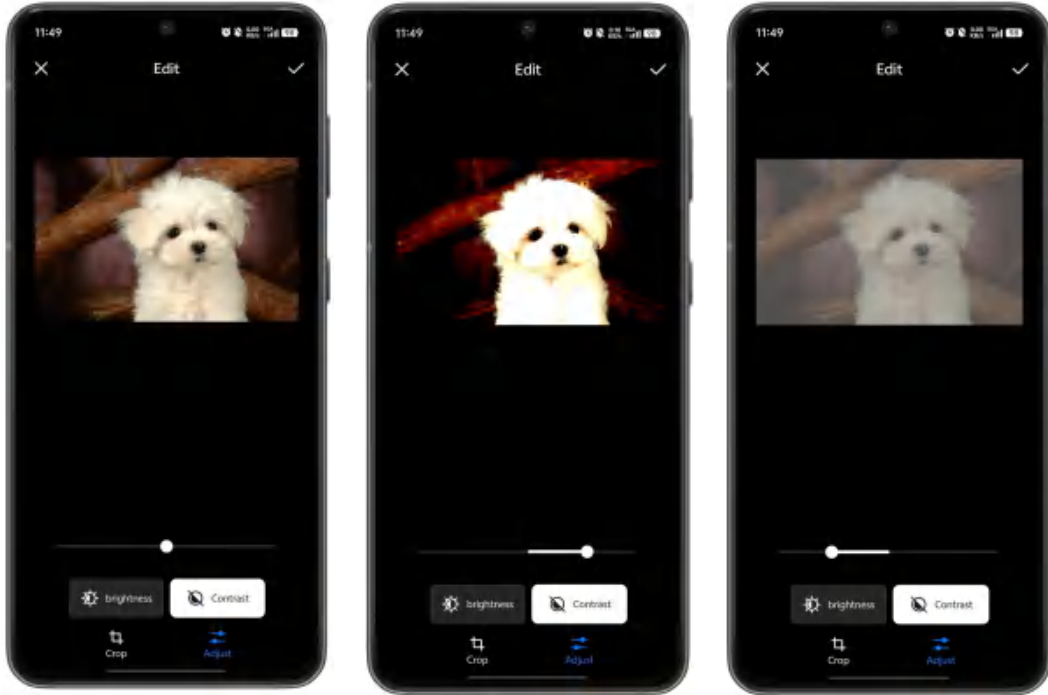

DIY Mode



Note 1: The name of the current authoring file.

Note 2: Finish button, click to enter the processing page

Note 3: Hide the DIY function box

Note 4: Vector selection, the content generated by the DIY is a vector image

Note 5: Bitmap selection, the content generated by DIY is bitmap, and it can choose different sizes of brushes for DIY

Note 6: After clicking OK, the edited content will be generated in the canvas

Note 7: Doodle content edit box
Note 8: Brush, must be selected when editing DIY content, and the default is selected Annotation

Note 9: When selected, you can move the content edit box. If you want to continue editing, you'll need to reselect the brush

Note 10: Undo, revert to a previous state or action

Note 11: Revert to revert to the previously undone operation

Note 12: Clear the current DIY.

DIY Mode Vector Selection:

After selecting and confirming the vector drawing content in the drawing, the vector drawing will be generated and added to the canvas, and the generated content will be selected by default.







NOTE 1: The length and width of the canvas selection, editable, and the ratio of length and width can be locked by the button in the middle

Note 2: The angle of rotation of the selected content in the canvas

Note 3: Delete button, click to delete this content

Note 4: Rotate button, press and hold to move to rotate the content

Note 5: Function button, click to pop up the box, you can set the corresponding processing parameters

Note 6: Zoom button, press and hold the zoom button to move outward or inward to zoom out or zoom in on the selected canvas content

Rotate and zoom: It can click the Select and Zoom buttons to select and zoom out of the pattern in the canvas.

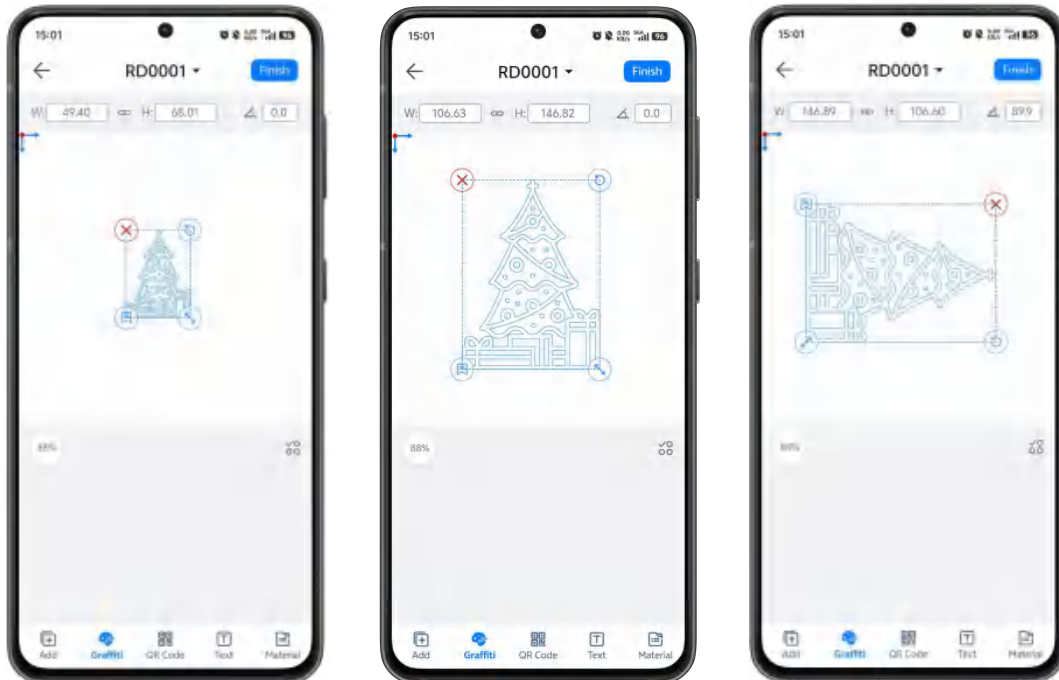

Click the function button to set the relevant parameters of cutting, such as cutting speed, power, processing priority and output, and the interface is as follows:



DIY mode bitmap selection:

Under bitmap selection, IT can use different sizes of brushes to draw separately, and when the drawing is complete, click OK to generate an image and display it in the canvas. You can perform operations on the bitmap as needed.

Note: Vector selection generates content as cut, and bitmap generates content as sculpting.



DIY mode vector coexistence with bitmap:

The canvas can hold multiple content images. Click the box selection button to combine multiple content images, and unselect the box to restore the original multiple content images.

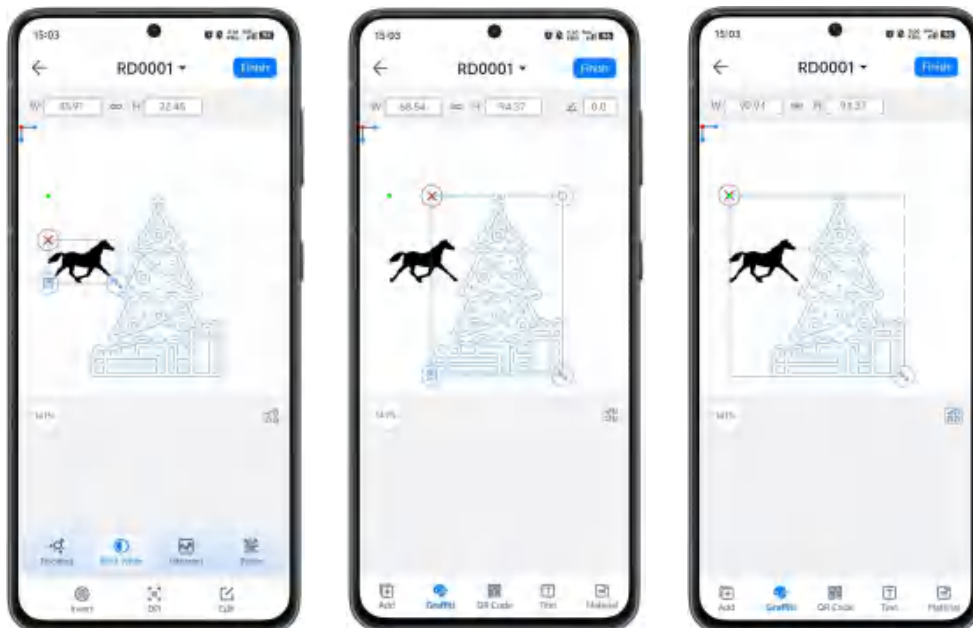

QR code mode:

It can choose to generate content with QR codes and bar codes, all of which are bitmaps, and the processing mode can only be engraving.



Text Mode:

After clicking on the text, you need to fill in the text content, and you can choose different fonts to generate a text image.

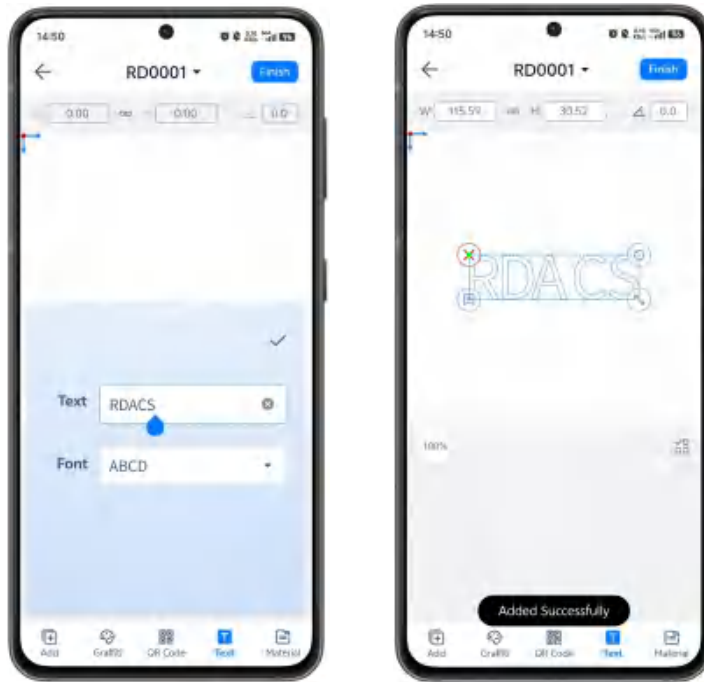

Click the text image to operate, you can choose to engrave or cut, the default processing method is engraving, after clicking to cut and confirm, the processing method of the text content will be changed to cutting.

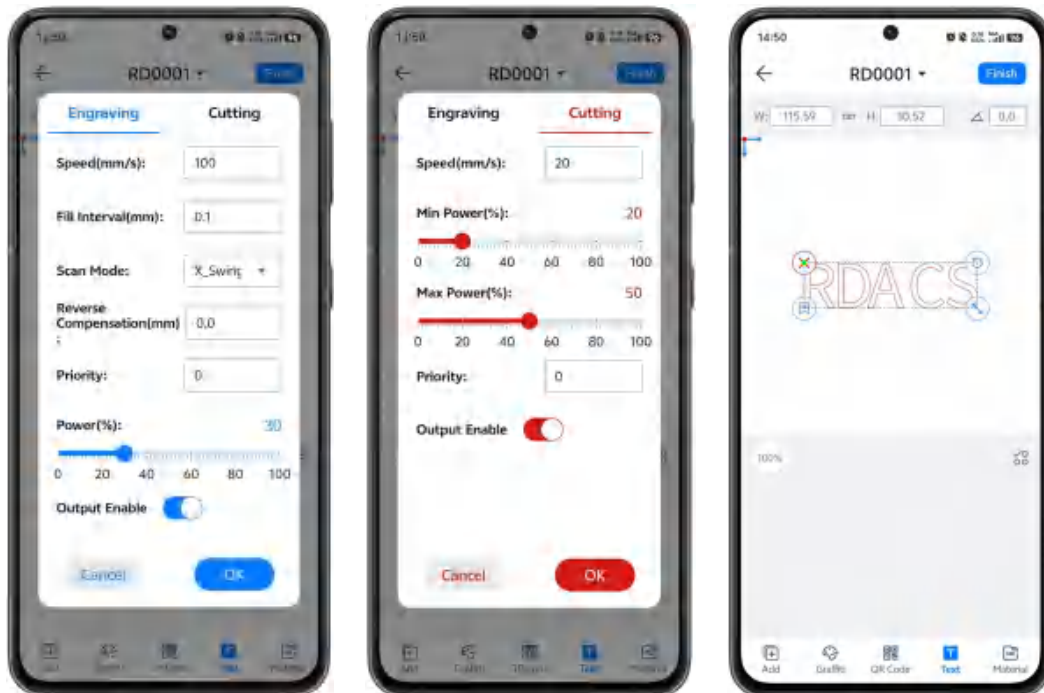

Creative Mode:

The creative mode provides some regular vector and bitmap assets.

The process of adding vector assets is as follows:



When click on the vector material to operate, you can choose to engrave or cut, the default processing method is engraving, after clicking Cut and confirm, the processing method of the vector material will be changed to cutting.

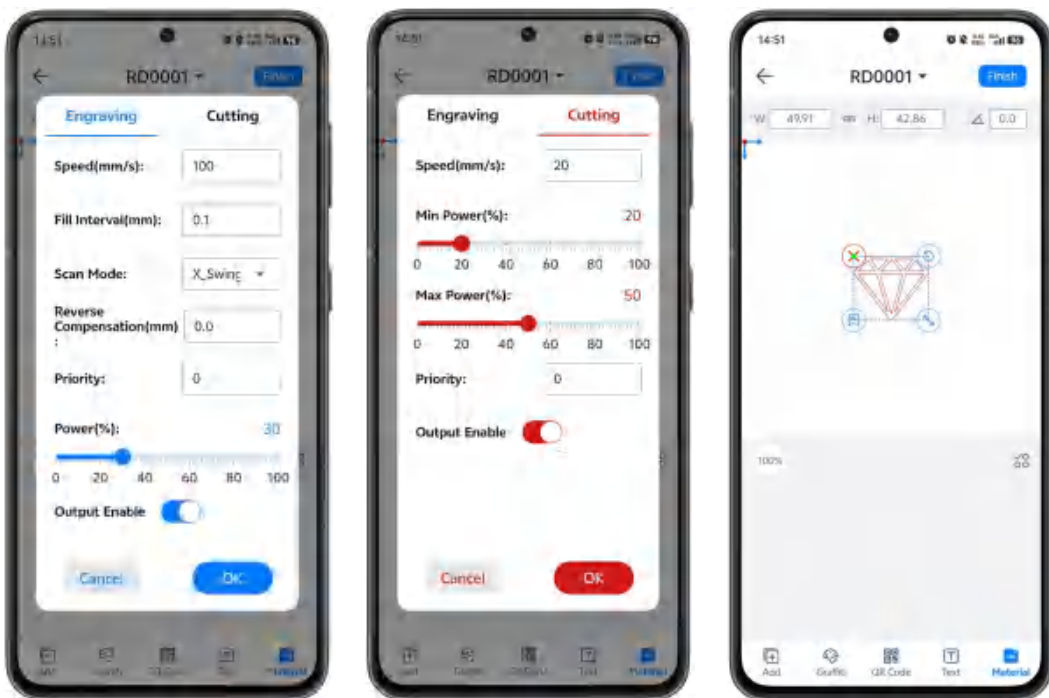

Bitmap Material:

Bitmap assets can only be processed in an engraving manner.

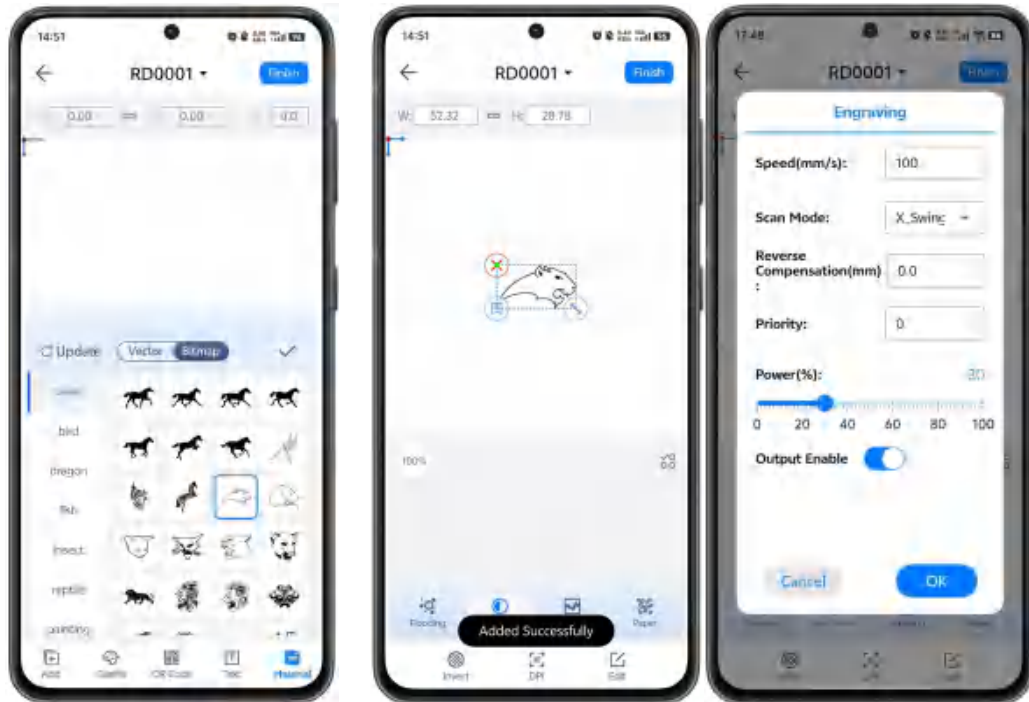

Click the Update button to update the library. If the account is not logged in, click Update, it will prompt that the account is not logged in, as shown in the following figure, click the login button and then jump to the login interface.

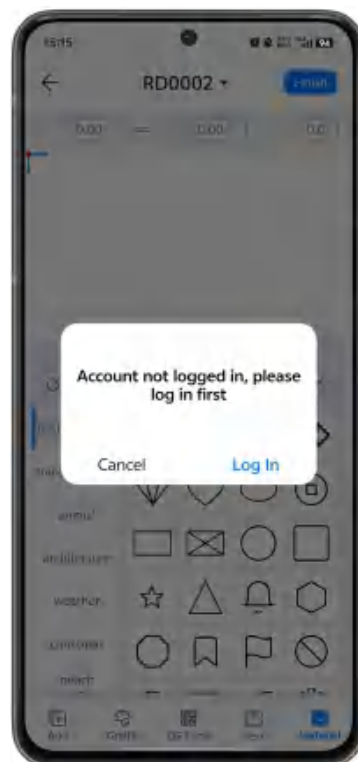

Finish button:

After finish creating, click the Finish button in the upper right corner, and the page will be displayed as follows, in this interface, you can also rename the file.



Save: Generate a file in RD format and save the currently authored content to the local file list in the file module. If you have saved a file with the same name, there will be a prompt of whether to overwrite the file, and the overwrite will replace the original file with the same name.



Set Drawing Origin: You can set the drawing origin.

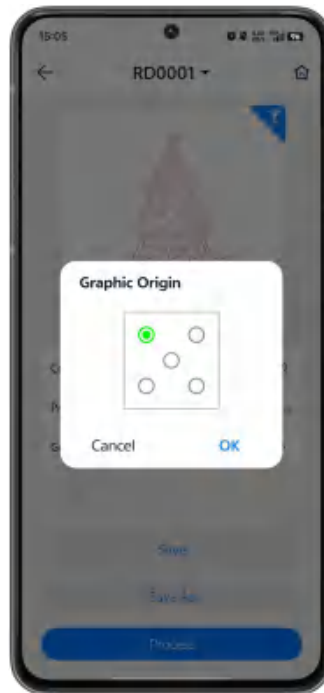

Processing: when the device is not connected, a prompt jump will be made; In the connected state, if there is a file with the same name in the board file of the control panel, it will prompt whether to overwrite it (the overwrite will replace the content of the file with the same name on the motherboard on the current canvas). If there is no file with the same name, the current content will be saved and written to the motherboard, and then the processing control interface will be redirected.

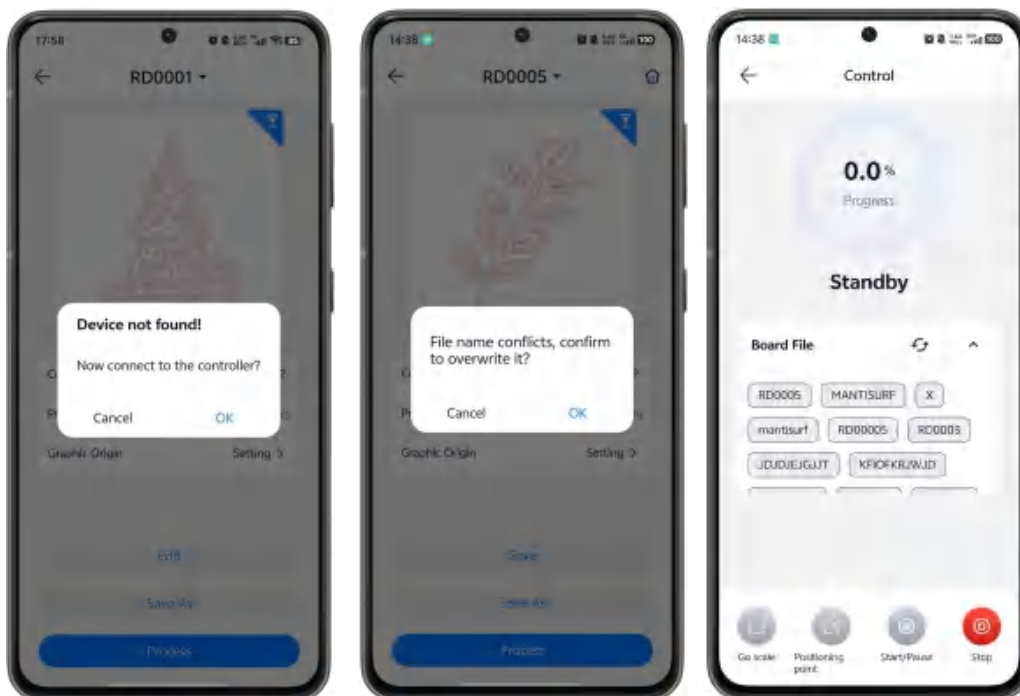

12.3 File module

This module is divided into two content lists: local files and cloud files, local files manage the local rd files stored in the APP, and cloud files manage the files uploaded to the cloud with logged in accounts.

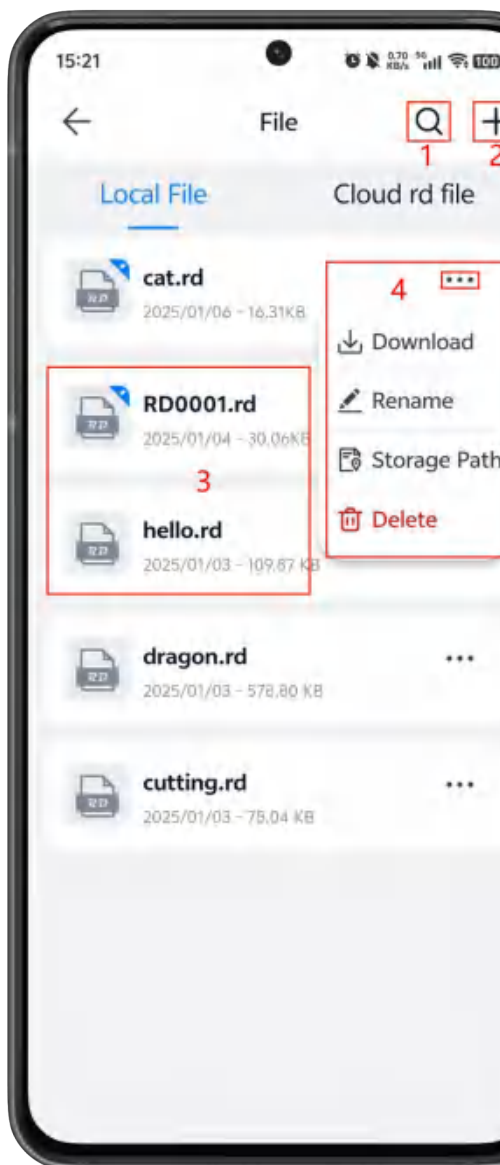

Note 1: Search function, search and match files.

Note 2: Import function, import mobile phone Chinese and store in the local file list.

Note 3: If this icon does not have a corner mark, it means that the file is an imported file or a file downloaded from the cloud. **If there is a badge, it means that the file is generated and saved by the authoring module.**

Note 4: After clicking, you can perform more operations on the file:

(1) Download to your device

(2) Rename

(3) Storage path

(4) Deletion

The following figure shows the initialization interface for local and cloud files:

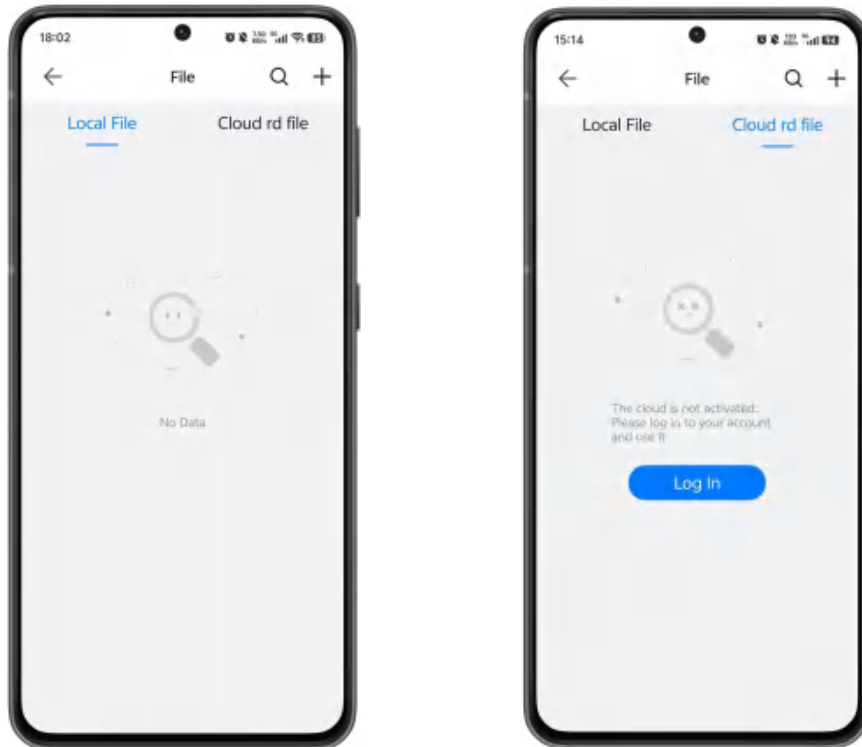

When data is available:

The files saved by the authoring module appear in the local file list; In the cloud file list, if there are files in the cloud of the account after logging in, they will be synchronized and displayed.

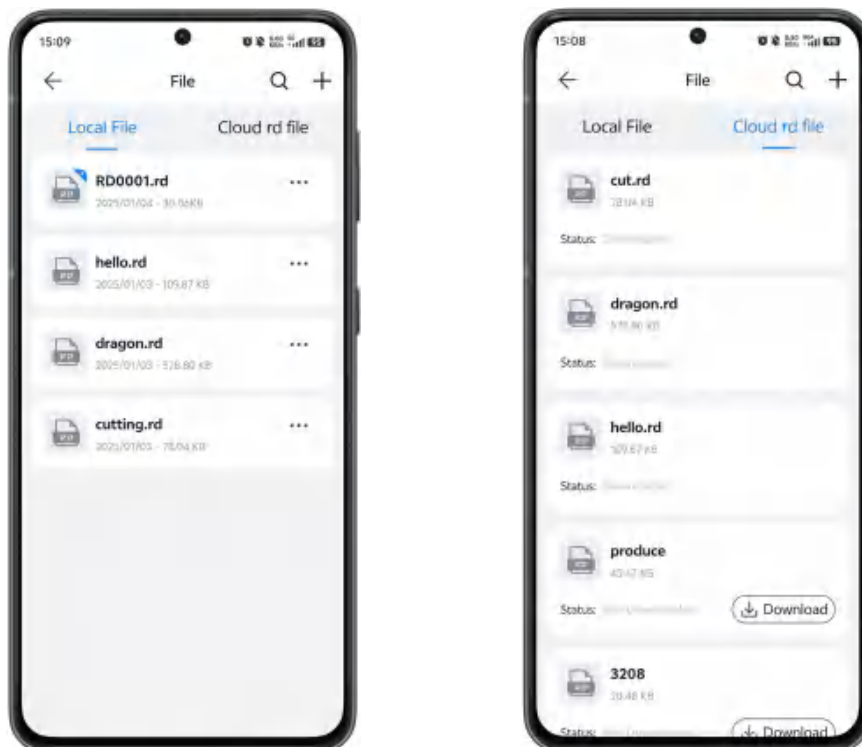

After clicking on the cloud file to download, the same file will be generated and saved and displayed in the local file list. The naming rule of Chinese files in the local file list is up to 4 Chinese or 8 English letters, if the name of the cloud file does not meet this rule, a pop-up window will be displayed, and the name that meets the rule can be renamed, and the file can be generated and saved to the local file list.

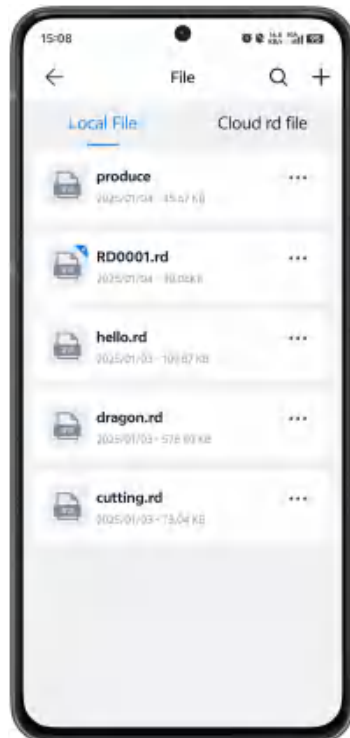
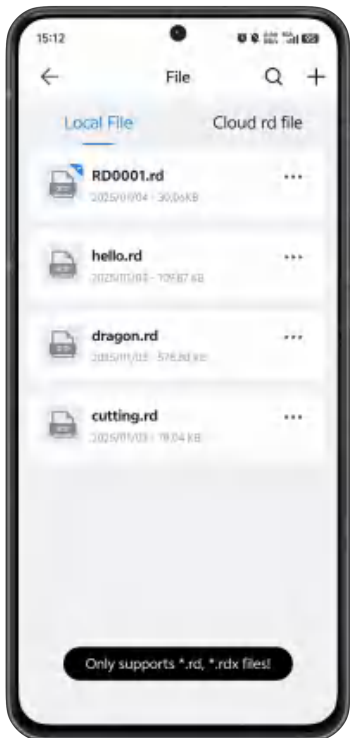
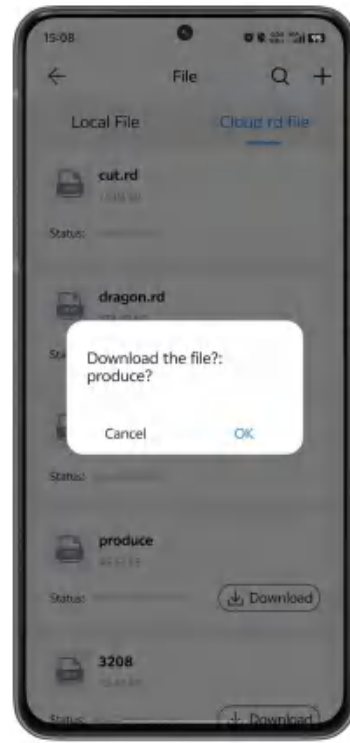
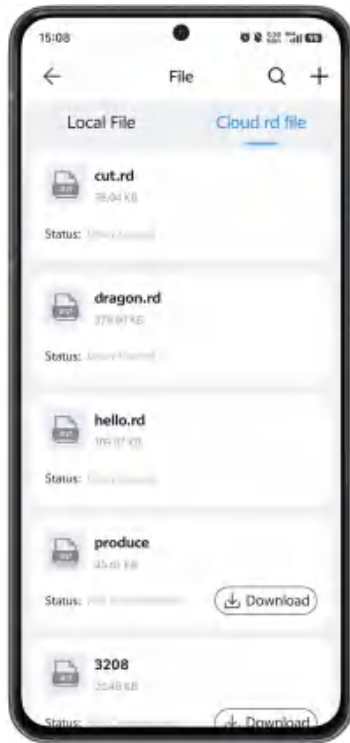

Click on a file to preview or edit the current file.

Files marked with 1 do not have a corner mark, indicating that they are imported files or cloud files.

Files marked with 2 have a badge to indicate that the file was saved through authoring.

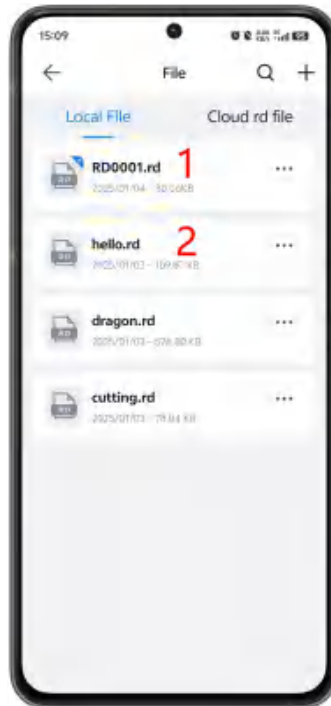

Cloud files and imported files can only be processed immediately, while the saved files can be edited by clicking the edit button to enter the creation interface.

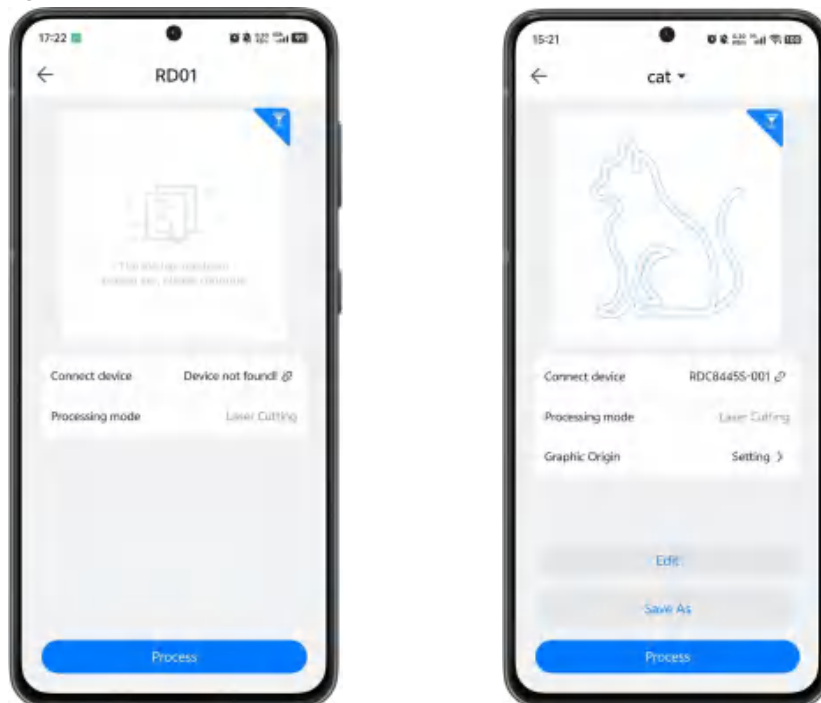

More for local files:

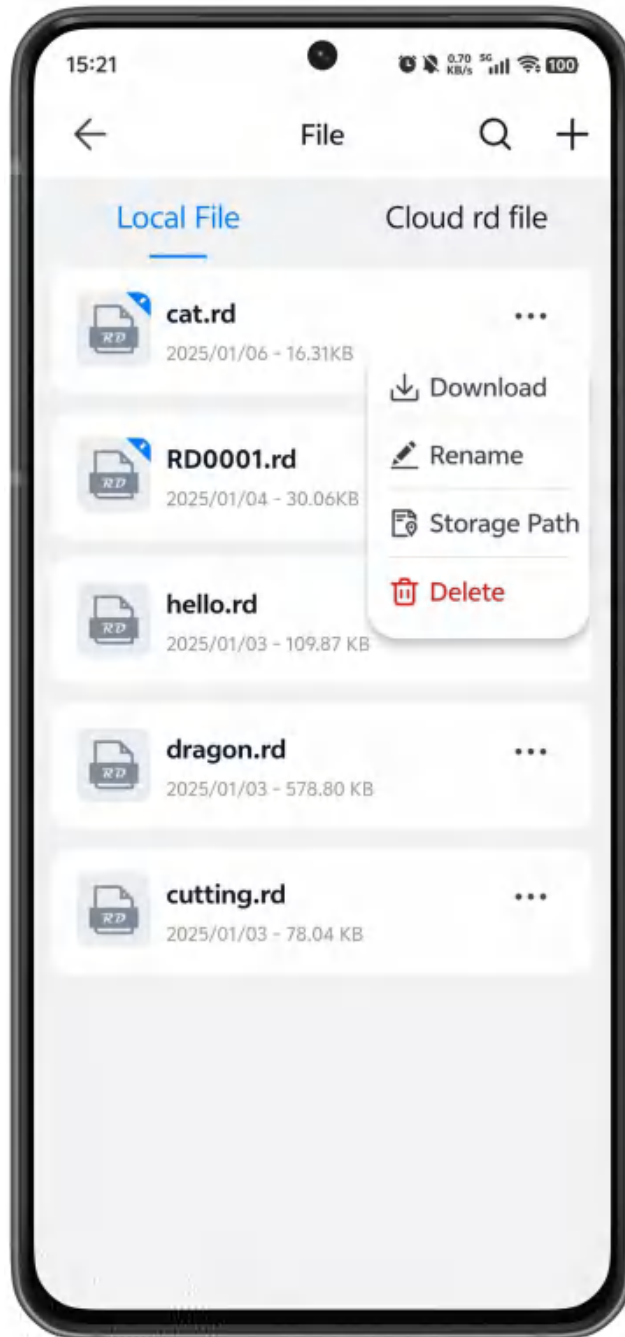

Download to device: Write the file to the motherboard, and it will prompt when the device is not

connected. If there is a file with the same name on the motherboard, it will prompt whether to overwrite it, and the overwrite will write this file and replace the file with the same name of the motherboard, please be cautious

Operate.

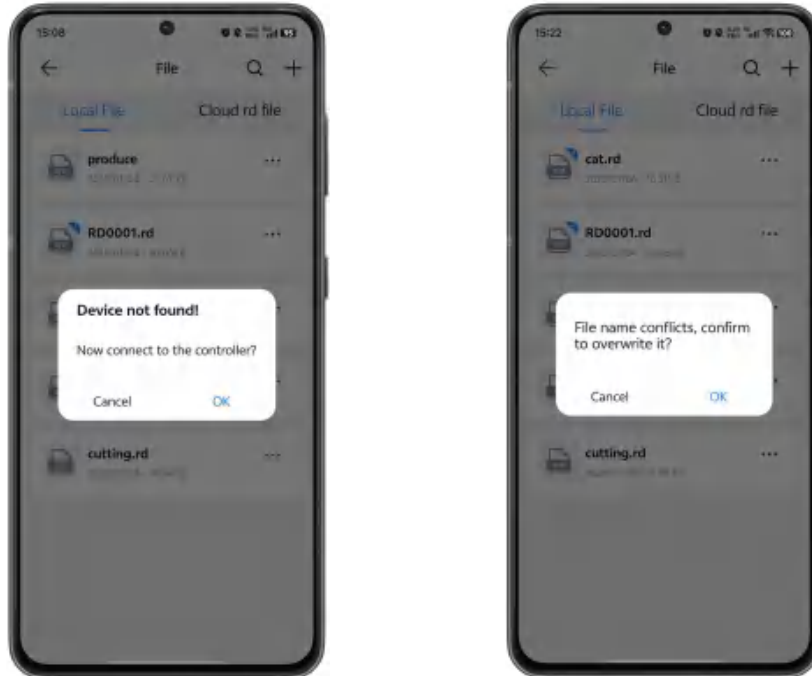

Rename: Rename the file, no files with the same name are allowed.

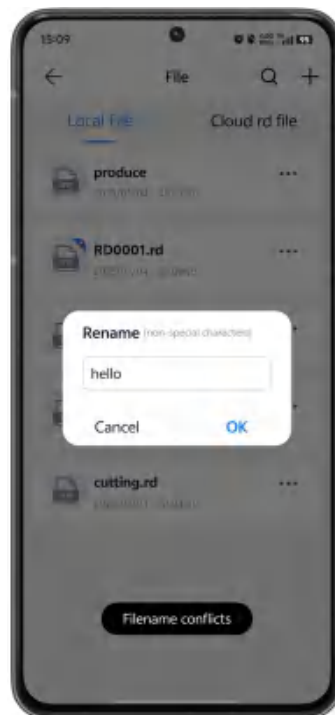

Local Path: displays the storage path of the file.



Delete: Deletes the selected files.

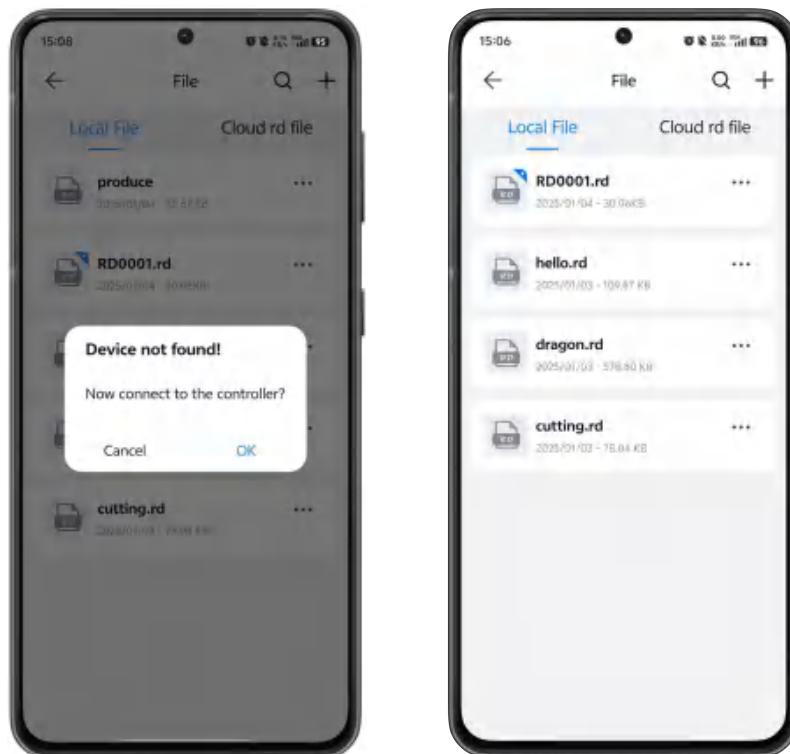

Local File Import:

Click the Add button to add files from your phone's storage.

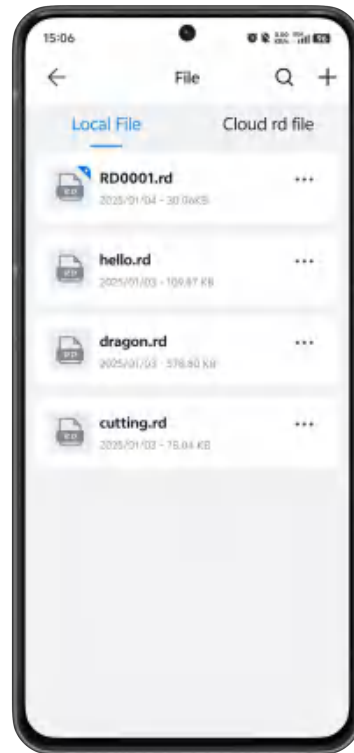

Click Search to quickly find the file you want to import, and then click on the file to import it.

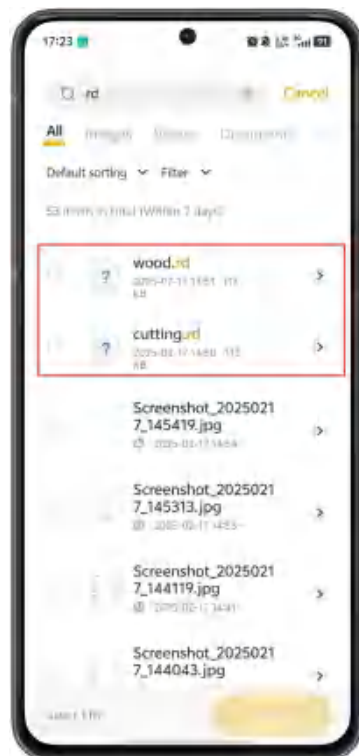

Only RD and RDX files can be imported.

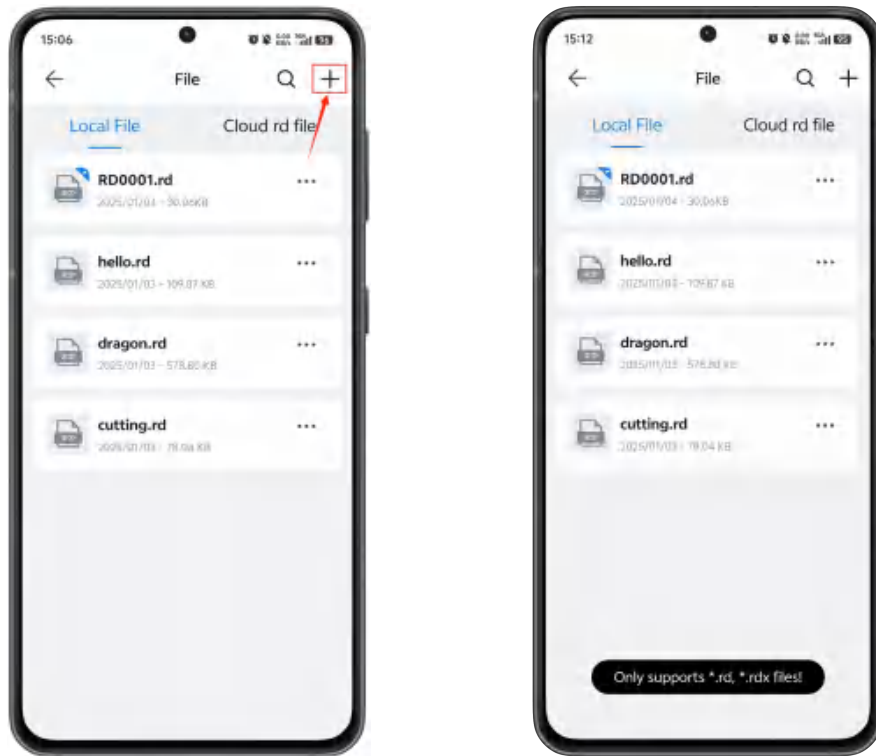

File module search function:

Click the search button to search for files, and you can search and match local files and cloud files respectively.

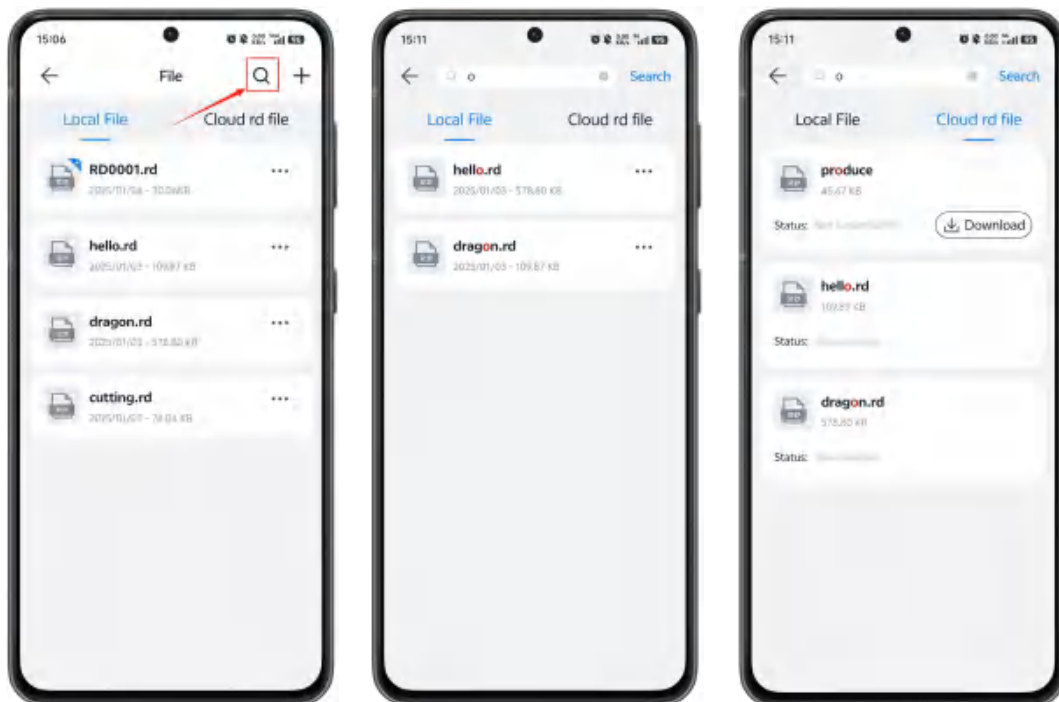

12.4 Equipment debugging and equipment parameters

12.4.1 Equipment debugging

Click Debug Device in the right function bar to debug the device as follows:

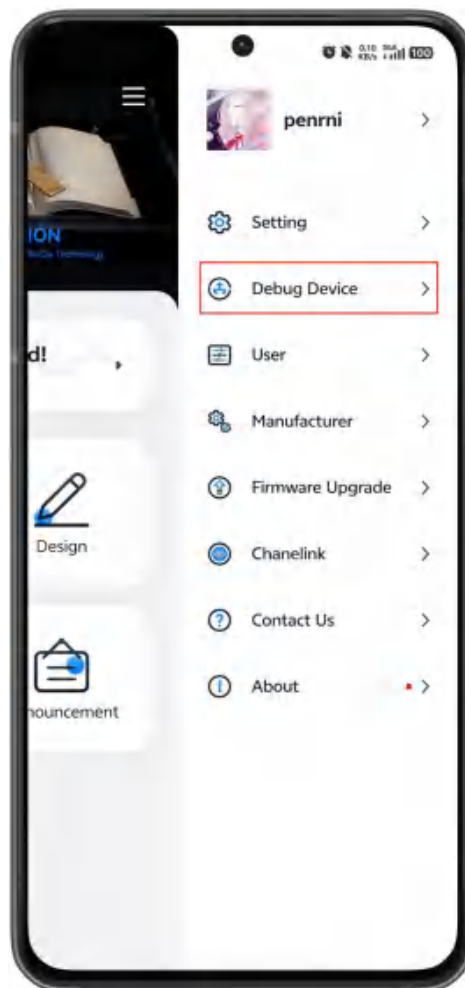

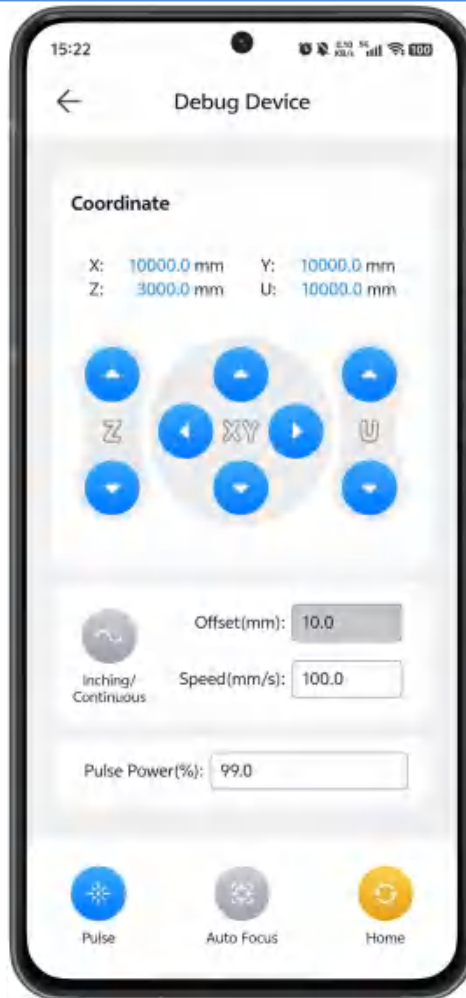

Laser head movement: Click or press and hold the blue button to control the corresponding coordinates

Jog/Continuous Button: When clicked, it can switch between jog and continuous mode. In jog mode, it can set the offset and speed, and after setting, when click or press and hold the button to adjust the coordinates, will move at that speed until it stops when it moves to the set offset value; In continuous mode, it can only set the speed, and when press and hold the button to adjust the coordinates, it will keep moving until loose it.



Pulse: it can click on the laser head to emit laser, so as to observe whether the equipment emits light normally.



Autofocus: Click the confirm button to make the machine autofocus.

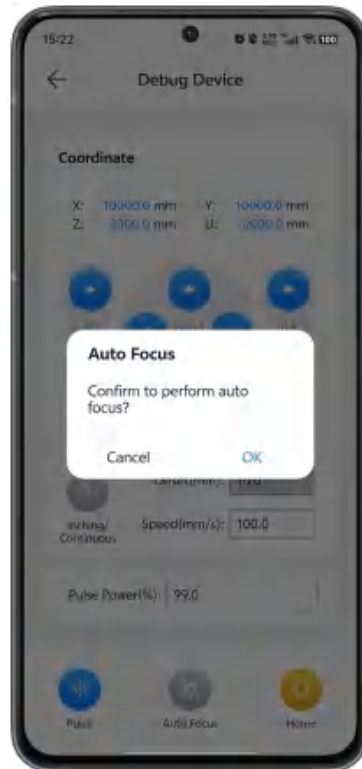

Origin: Reset each axis of the machine (need to enable reset in the parameters).

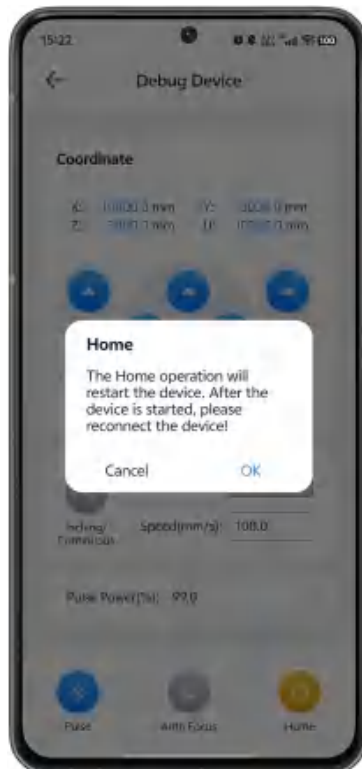

12.4.2 Device parameters

Click User Parameters and Manufacturer Parameters in the right function bar to view and modify these parameters.

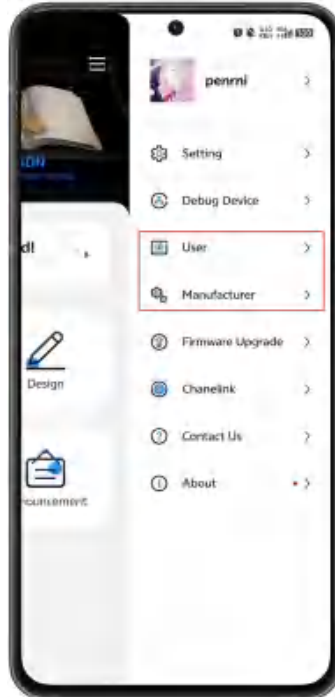

User parameters: After clicking the user parameters, the interface is as follows, you can click Read Parameters to read the device user parameters (enter this page to automatically read the user parameters and display), and you can modify or select the value of the parameter bar to modify the parameters.



Vendor parameters: click on the manufacturer parameters and ask to enter the manufacturer parameter password, enter the manufacturer parameters page after the password verification is completed, you can click to read the parameters to read the equipment manufacturer parameters (enter this page will automatically read the manufacturer parameters and display), you can modify or select the value of the parameter bar to modify the parameters.

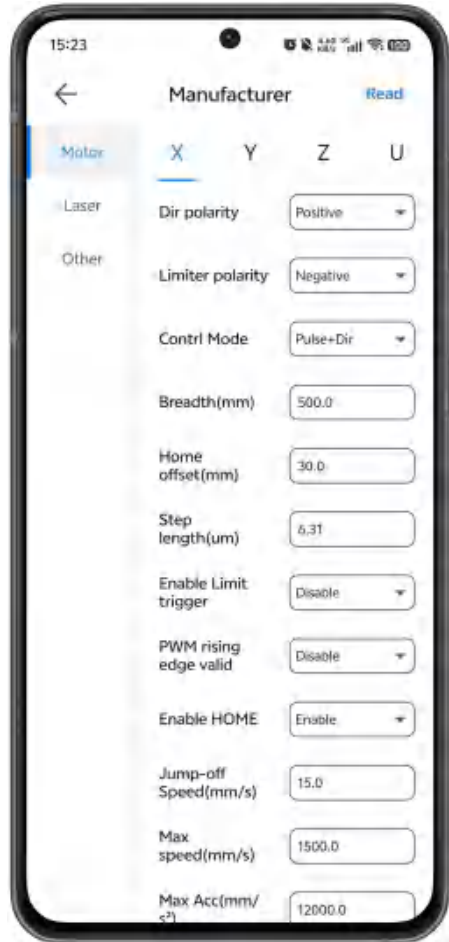
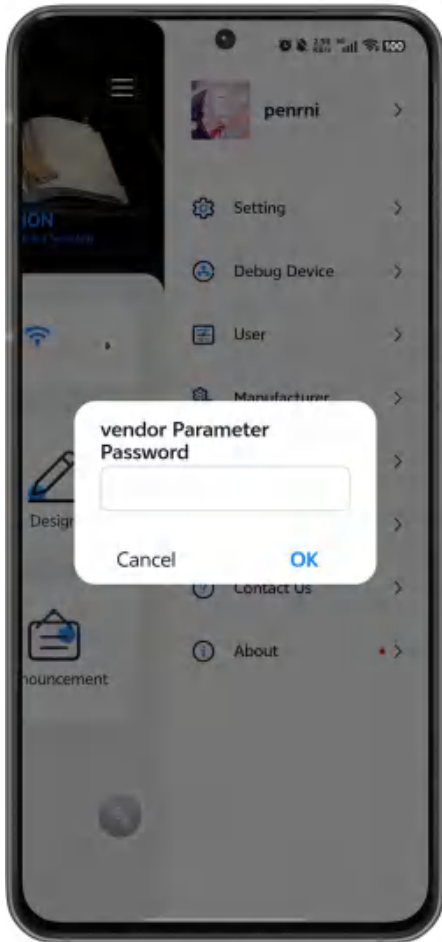

12.5 Firmware upgrades

In the firmware upgrade product library, some firmware of the corresponding board will be listed, click to view the content of the firmware version update. Click Download, and the downloaded firmware will be stored in the downloaded list.

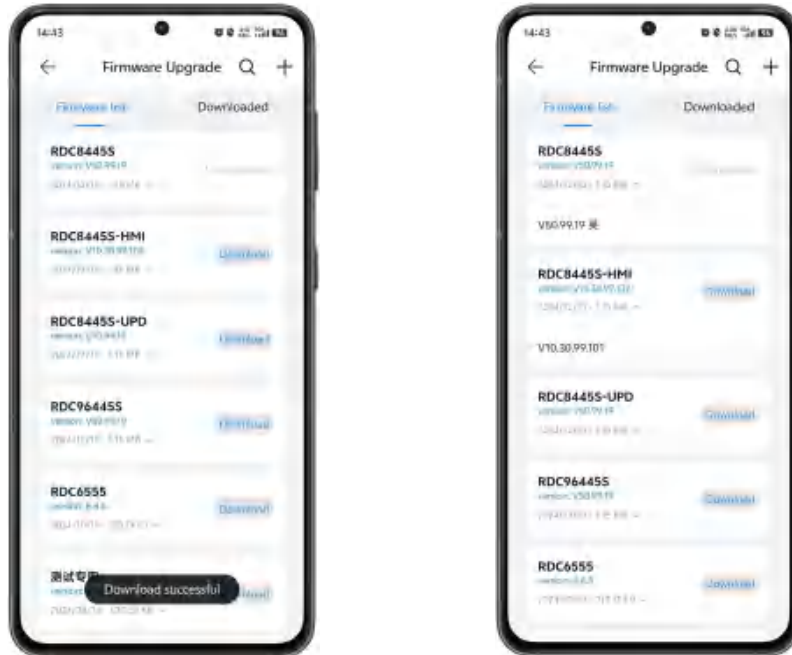

Downloaded list:

After the firmware is successfully downloaded in the product library, you can select the corresponding firmware, click Upgrade, and the firmware will be written to the motherboard in the connected control panel and upgraded.

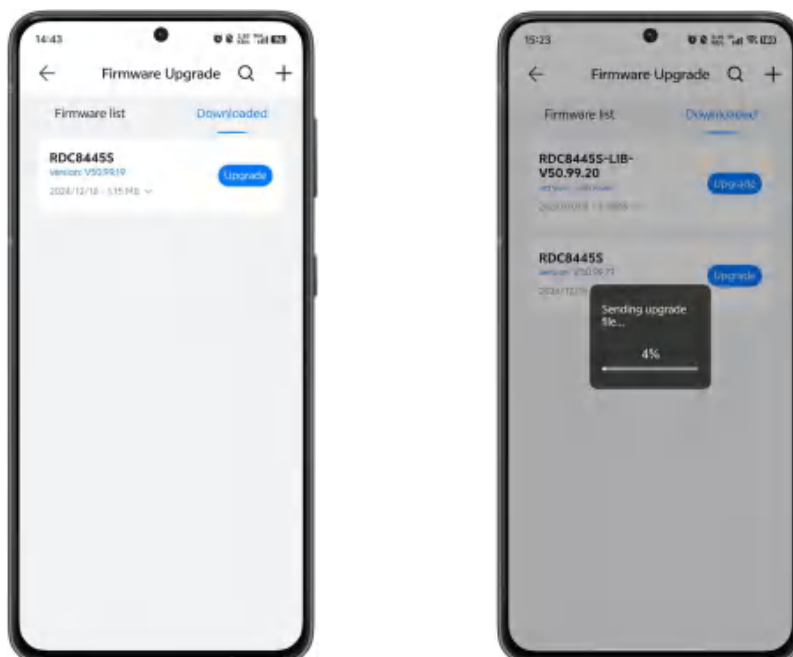

When it is not connected, it will prompt that the device is not connected, as shown in the following figure:



In addition to downloading the upgraded firmware from the product library, you can also import it from your phone's storage by clicking the Add button in the upper right corner. In addition, it also supports opening and importing from other APPs, when receiving a file in the format of upd in software, click on it, then click to open it with another application, and then select Mantisolo, and finally click always or only this time to confirm, you can import this file (the version of the imported file is unknown, and the upgrade instructions also clearly change the firmware to the imported file)

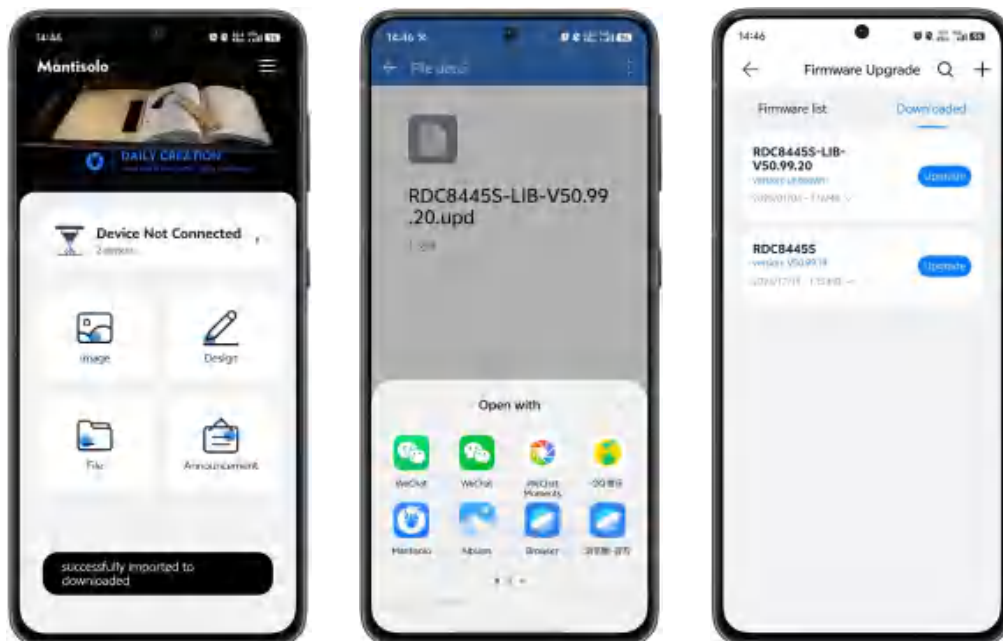

Firmware that has been downloaded from the list can be manually removed.

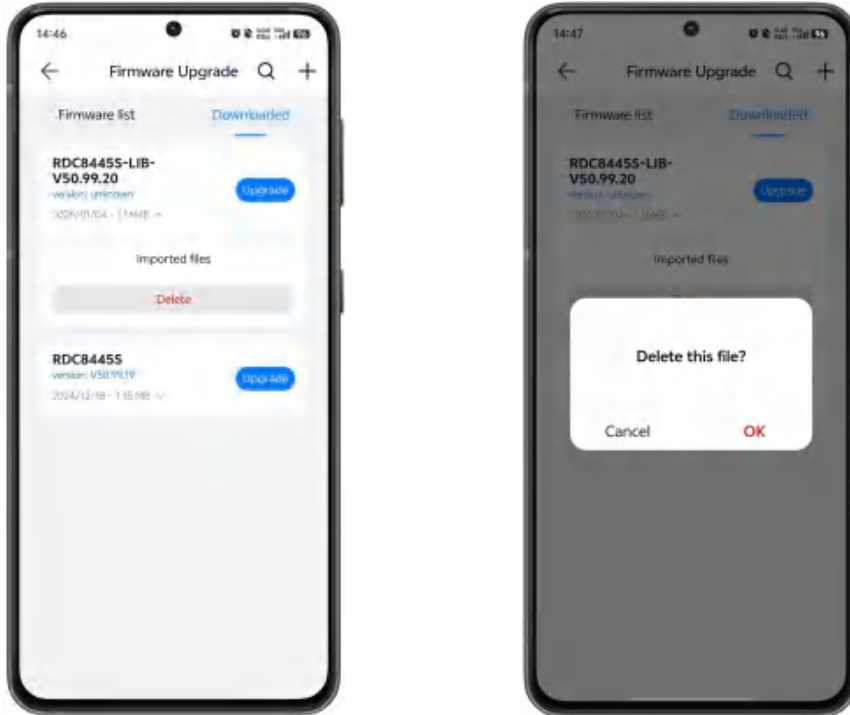

Firmware upgrade module search function: You can use fuzzy query and precise query to search for firmware products in the product library.

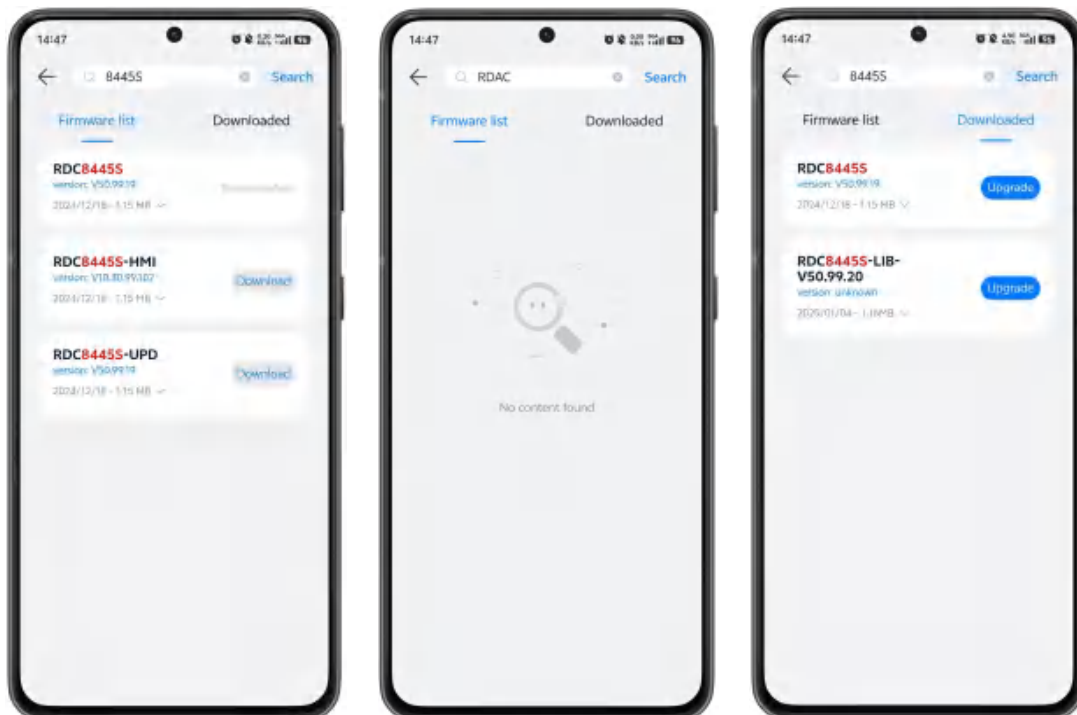

12.6 User module

Account:

View and edit user information, and when the user is not logged in, click to jump to the login screen.

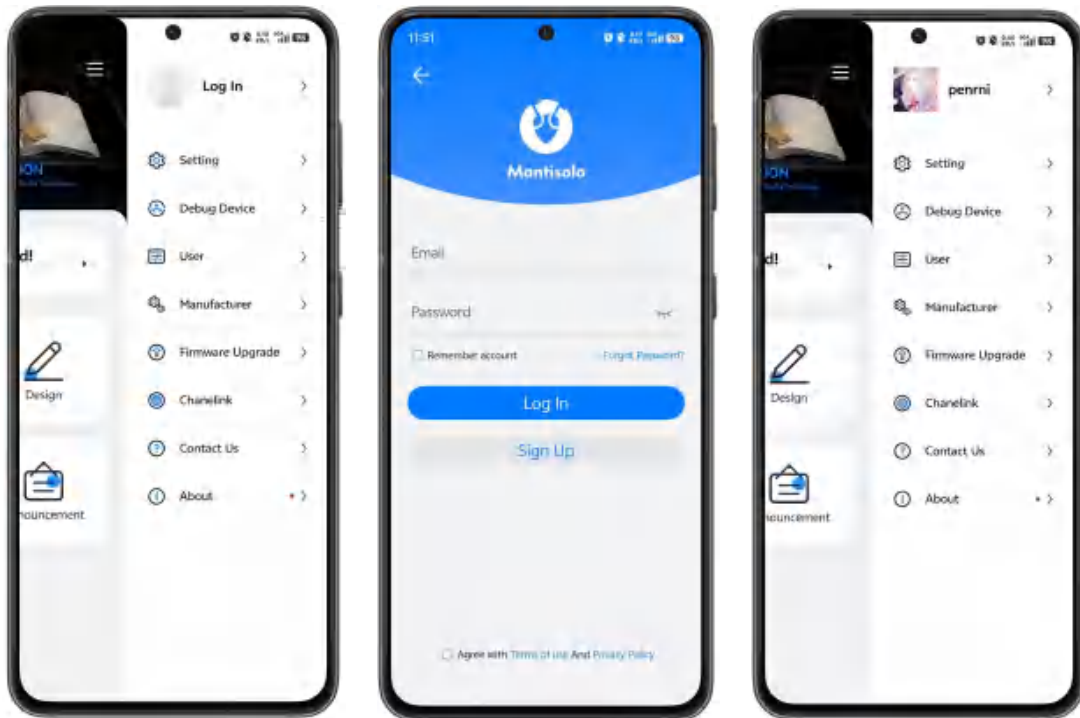

If you have not registered, you can enter the registration page to register an account:

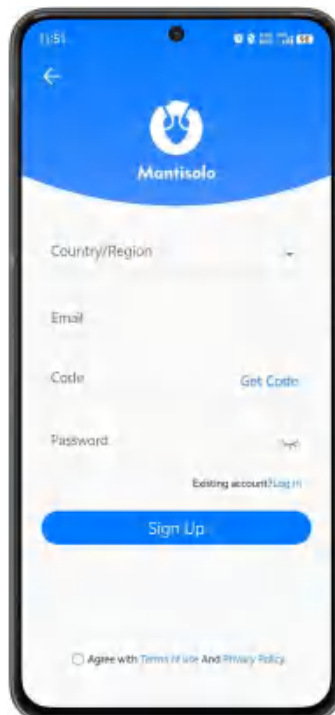

If forgot your password,it can click Forgot Password to reset it on the following page:

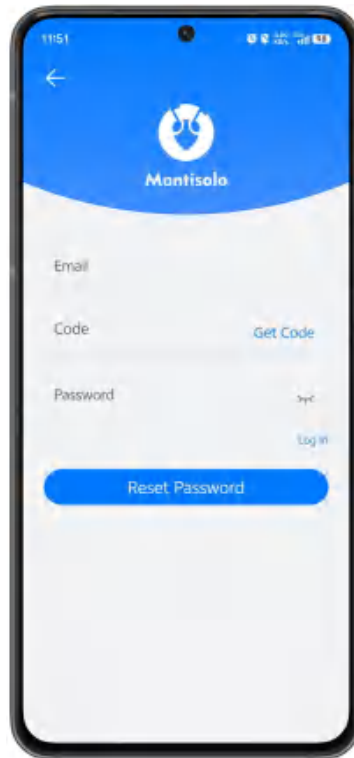

After successful login, it can edit the user information and change the account information such as nickname and mobile phone number.

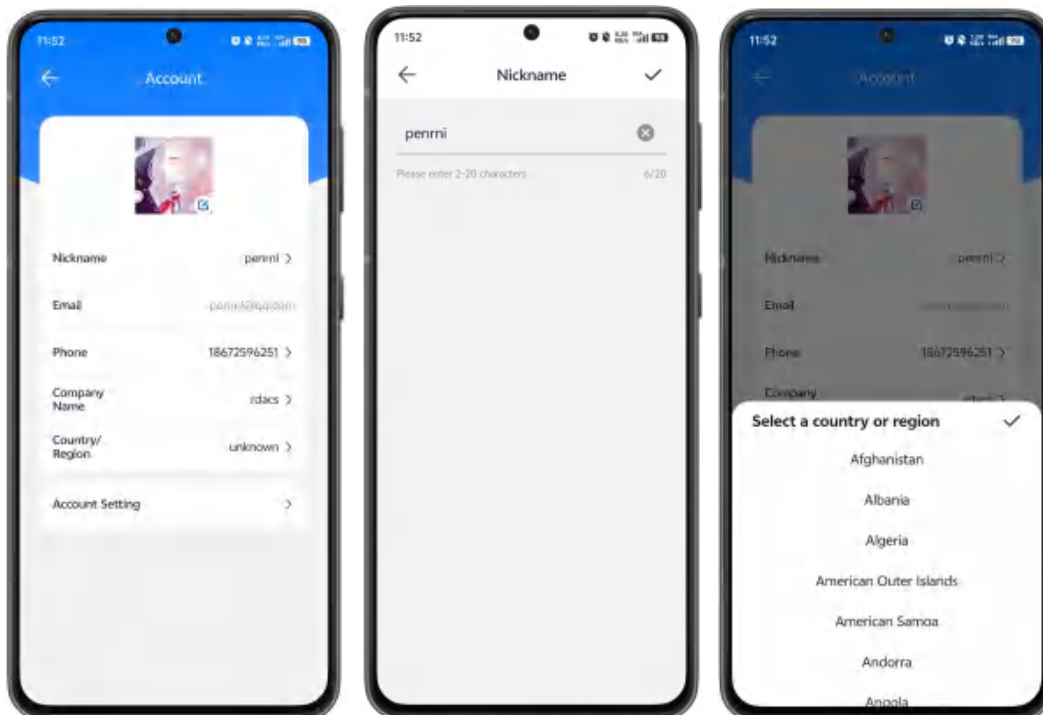

Edit profile:

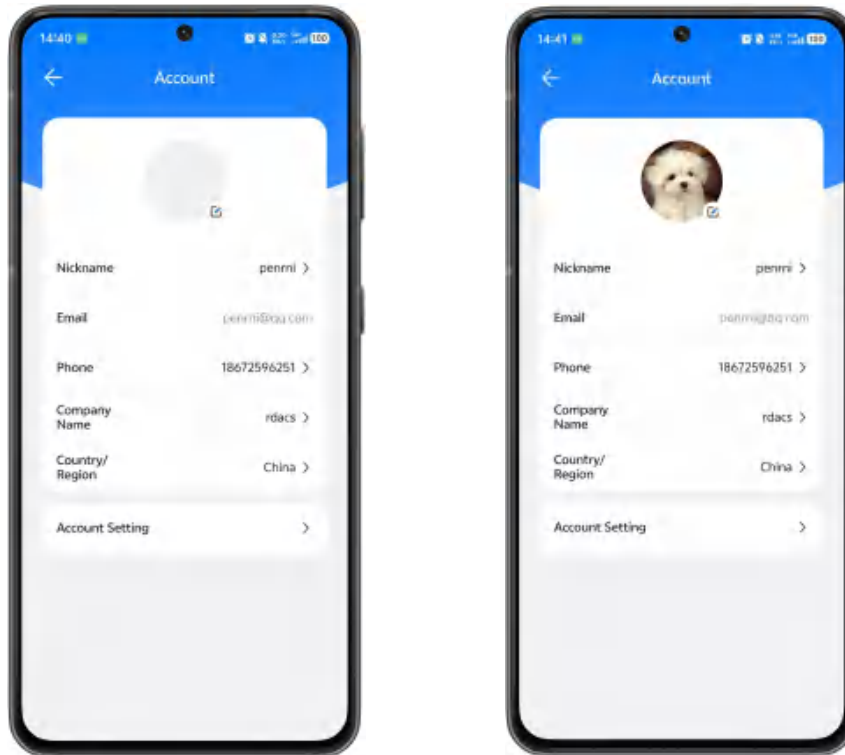

Account settings: Click on account settings to change your password and cancel account.

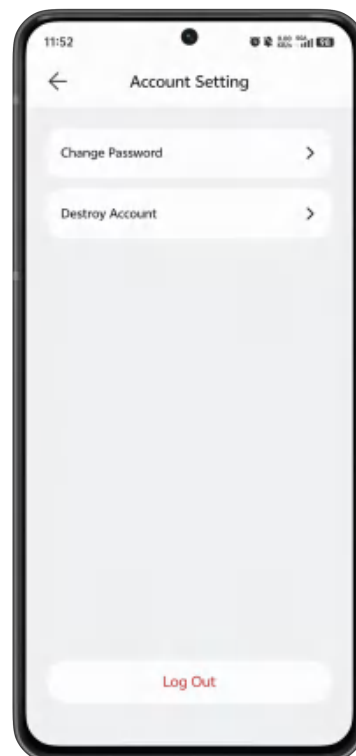

Change password: Enter the original password, then enter the new password, and

click Confirm to change it.

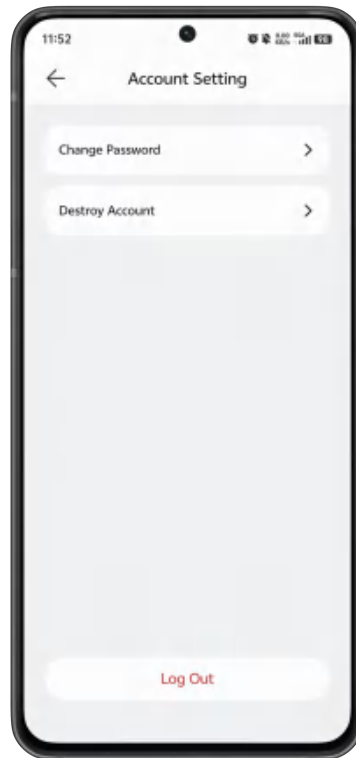

Account cancellation: it needs to read the account cancellation instructions first, and cancel the account after verification.

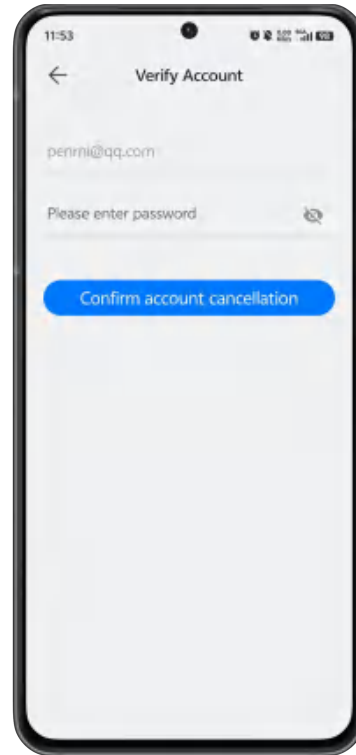
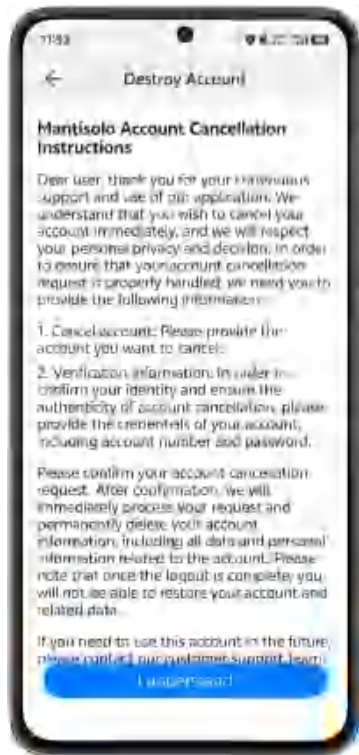

Settings: switch between device modes and languages.

Mode switching: switch modes.

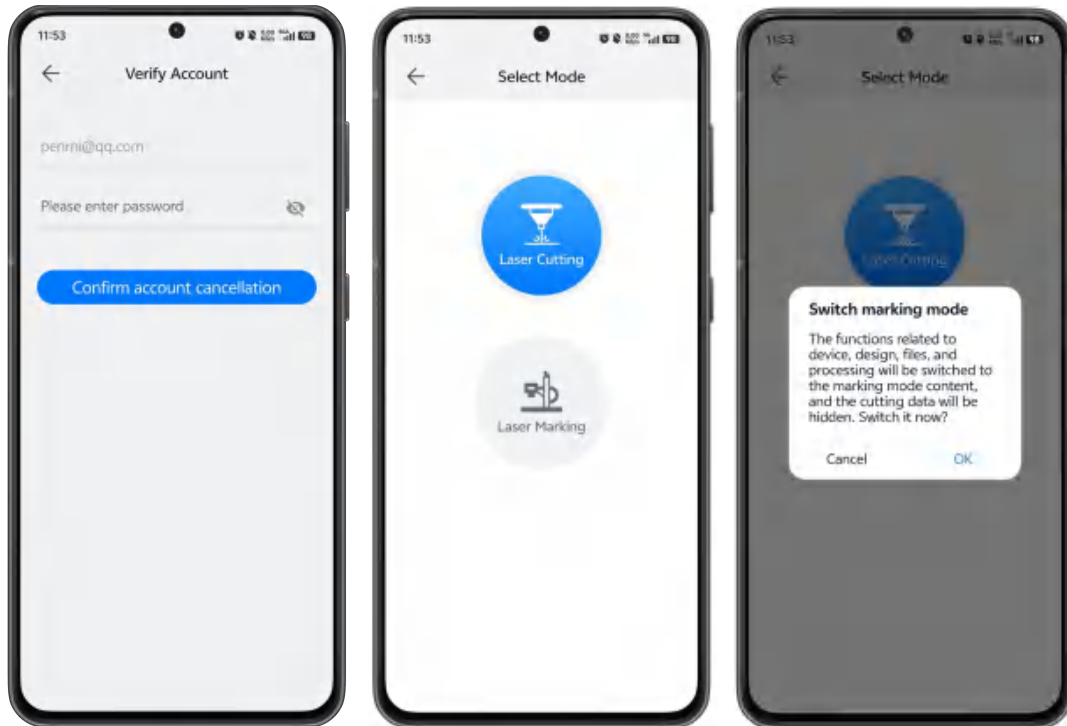

Language Switch: Switches the system language.

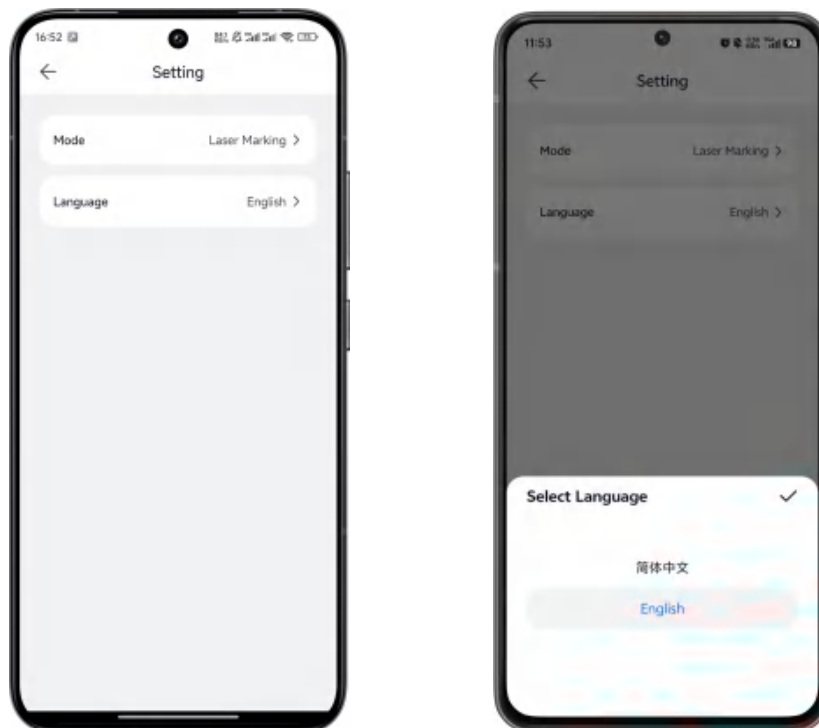

12.6 Other features

Announcement:

Announcement interface, this interface only displays the latest 4 announcements, click to view the specific content of the announcement;

The latest announcement is the first one, which is displayed in the form of pictures;

Click All Announcements to view all announcements.

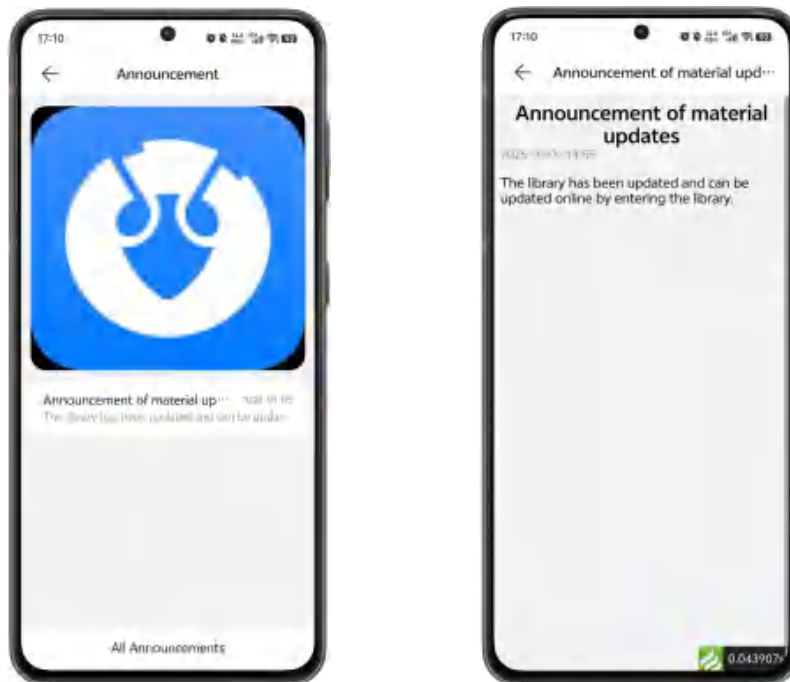

The full announcement page is shown below:



Contact us:

Display the company's address and contact information, as well as the QR code of the company's WeChat official account and Douyin account:



Chanelink: Chanelink is a comprehensive platform that provides technical exchange and learning, video sharing, and material download in the laser processing industry. It includes the official forum of Ruida. Welcome to join us!



About the software:

Check the new version to view the relevant information about the APP upgrade and upgrade. iOS will jump to the AppStore for update, and Android can be updated directly.

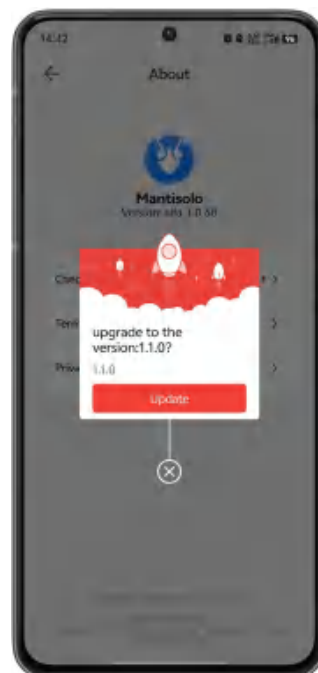
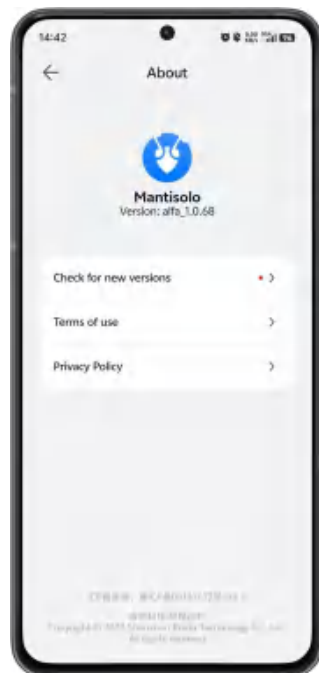

User Agreement and Privacy Policy, respectively, jump to the corresponding declaration page.

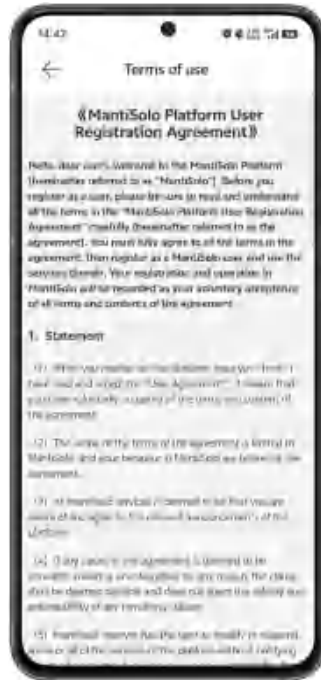

Section 13 Mantisurf User Guide

13.1 MantiSurf Introduce

Thank you for using the MantiSurf laser control web platform!

MantiSurf Web: <https://www.mantisurf.com/>

MantiSurf is a branch of the series of control platforms developed by the MantisX team of Ruida Technology, which is suitable for laser cutting and engraving applications.

The MantisX team has 16 years of experience in the laser industry to bring our customers a newer and better software product experience, which is the continuation and development of the innovative spirit of Thinking in motion.

The MantiSurf platform is cloud-based, requires no installation, and is ready to use. The function integrates CAD, CAM system, rich library resources, cloud parameter library, etc., which can be used by users to design and edit graphics and texts, and apply them to laser cutting and engraving.

13.2 Mainboard connection

13.2.1 The mainboard is connected to a WiFi hotspot

The mainboard needs to enable the wifi STA mode and connect to the wifi hotspot. In the control panel "menu--> controller settings--> network settings-->wifi settings" to configure, enter the wifi name and password, and then write the parameters, after the connection is successful, the router will assign an IP to the motherboard.

Mode: STA

Name: RDACS_5G

Password: 123456

IP address: 192 : 168 : 247 : 56

Read Write

Press <Shift> to open the lowercase letter soft keyboard

13.2.2 ENABLE WEB USAGE

Menu --> controller settings --> network settings + -->IOT settings +" to enable the IOT function, and then set the server, at present, the control card has three server options in Asia/Europe/Americas, and the user can set it according to the actual situation.

IoT settings: YES

Server settings: Asia

Device ID: 010019999999XJ01

Read

Write

13.3 User module

13.3.1 User Registration

1. Open the MantiSurf website (<https://www.mantisurf.com/>) and click [Register Now] at the top of the page.

(Note: Currently, only email registration is supported on the WEB.))

Login

Don't have an account? [Immediate Registration](#)

* Email

Enter Email

* Password [Forget Password](#)

Enter Password

Login

By logging in, you agree to the [User Agreement](#) and [Privacy Policy](#)

2. Enter the registration page and fill in the information according to the content, * is required. The registered account must be a real and usable email address, and receive an SMS verification code through the registered email address, and the registration can be successful after completing the verification and confirming the password.
(Note: By registering, you agree to the User Agreement and Privacy Agreement.)

Register 文A

Have an account? [Immediate Login](#)

- Email
Enter Email
- Verification Code
Enter verification code [Send verification code](#)
- Password
Enter Password

Phone
Enter Phone

Company Name
Enter company name

[Register](#)

By sign in, you agree to the [User Agreement](#) and [Privacy Policy](#).

13.3.2 The user retrieves the password

If the user forgets the password, he can click [Forgot Password] on the login page to reset the password according to the registered email address, and the password reset will be successful if the verification is passed.

Reset Password 

[Return to login](#)

- Email
- Verification Code
 [Send verification code](#)
- New Password
- Confirm Password

[Confirm](#)

13.3.3 User login

Enter registered email account and password to complete the login.

Login 

Don't have an account? [Immediate Registration](#)

- Email
- Password [Forget Password](#)

[Login](#)

By logging in, you agree to the [User Agreement](#) and [Privacy Policy](#).

13.3.4 Account settings

The user's avatar, account name and email address information are displayed here, and account settings, language conversion, help center, and logout operations can be performed. Click [Account Settings] to jump to the settings page, where you can modify your avatar, nickname, password, country, mobile phone number, and other information.

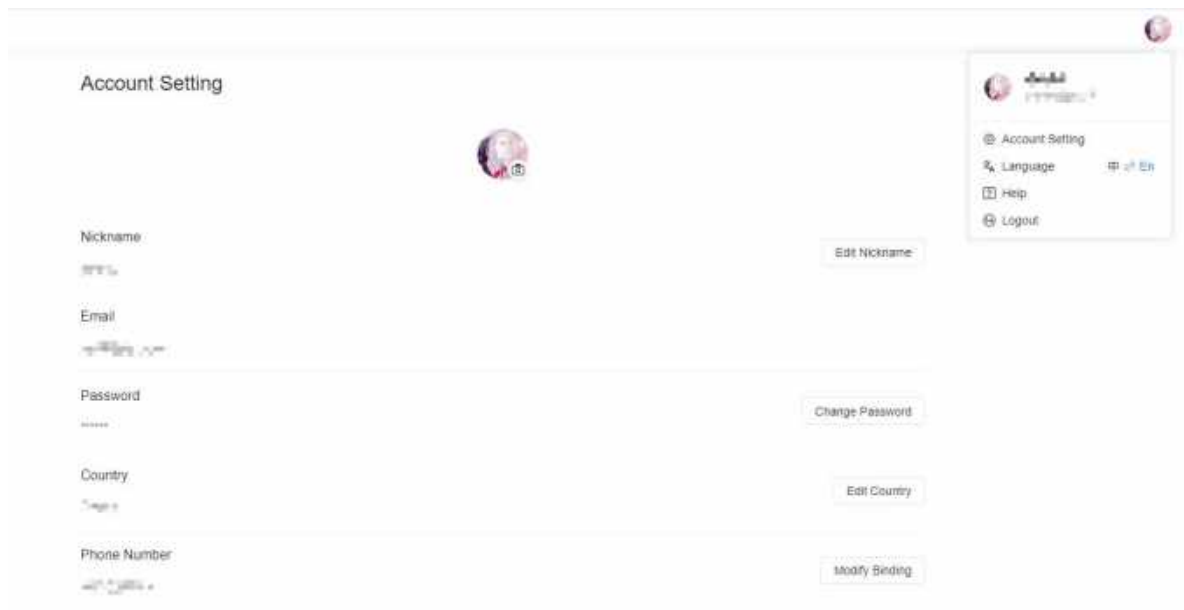

13.3.5 Language switching

The default of the website is Chinese, and there are two entrances to switch the language to English:

1. This button at the top right of the login page can switch to English mode, as shown in the figure.

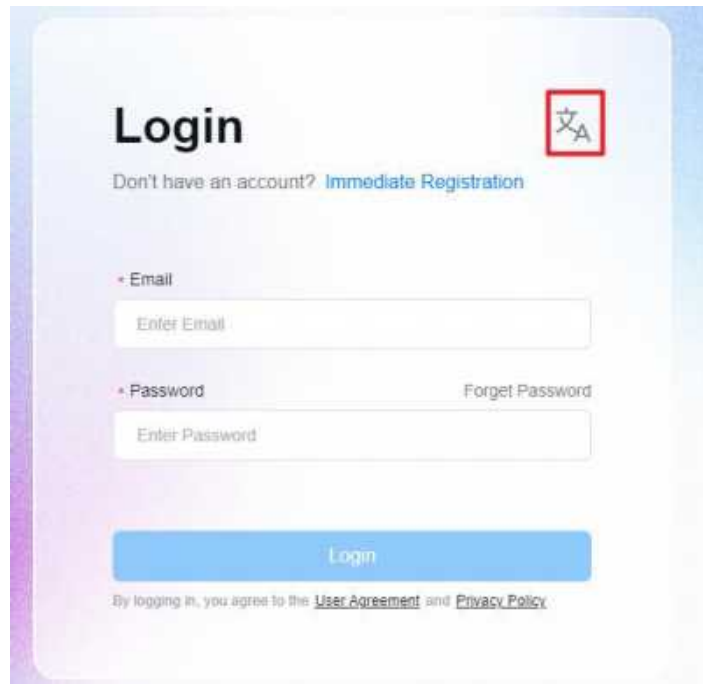

1. After logging in, click on the avatar at the top right of the page and
2. select [Language Switch].

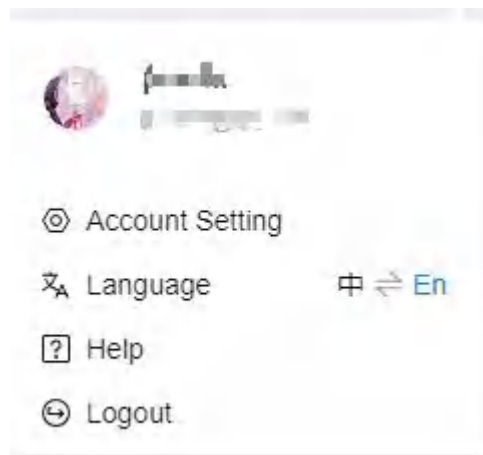

13.4 Equipment addition and blueprint generation

13.4.1 Equipment addition

Step 1: Click [Add Device] on the homepage to enter the device addition window, enter the device ID, and click Next. If you've connected your device before, you can select it directly from the list of devices.

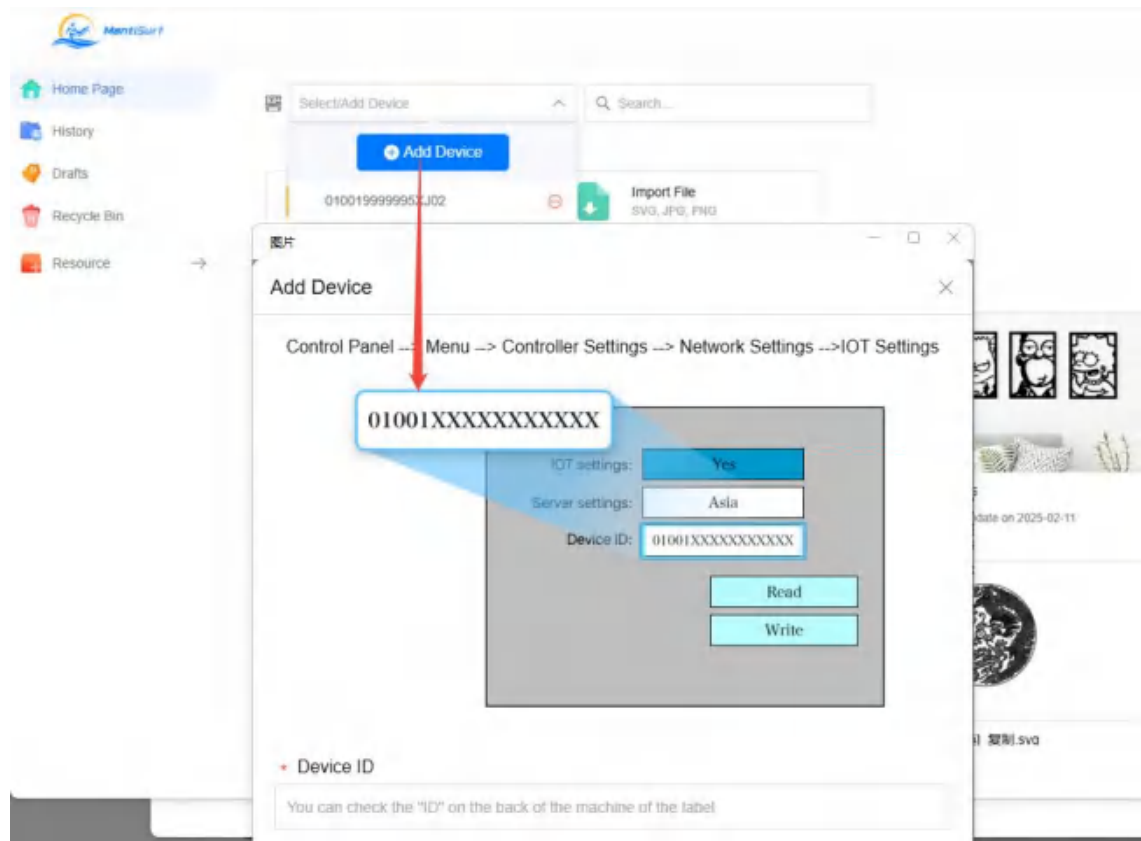

Step 2: After the device is successfully connected to MantiSurf, it automatically returns to the operation page. Now, it's time to start your creation!

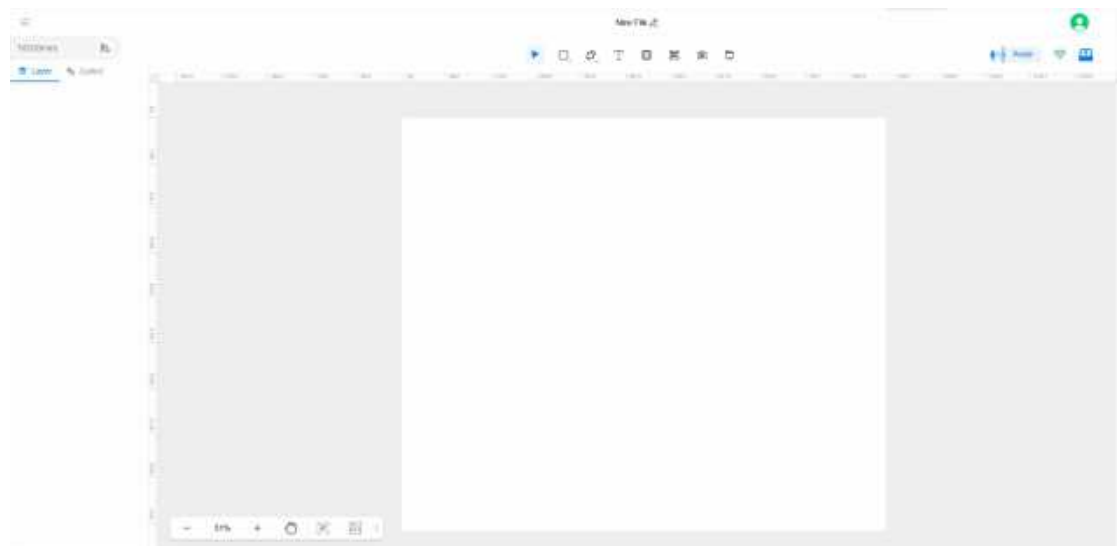

13.4.2 Create a new blank page

Click New at the top right of the home page to jump to the canvas page.

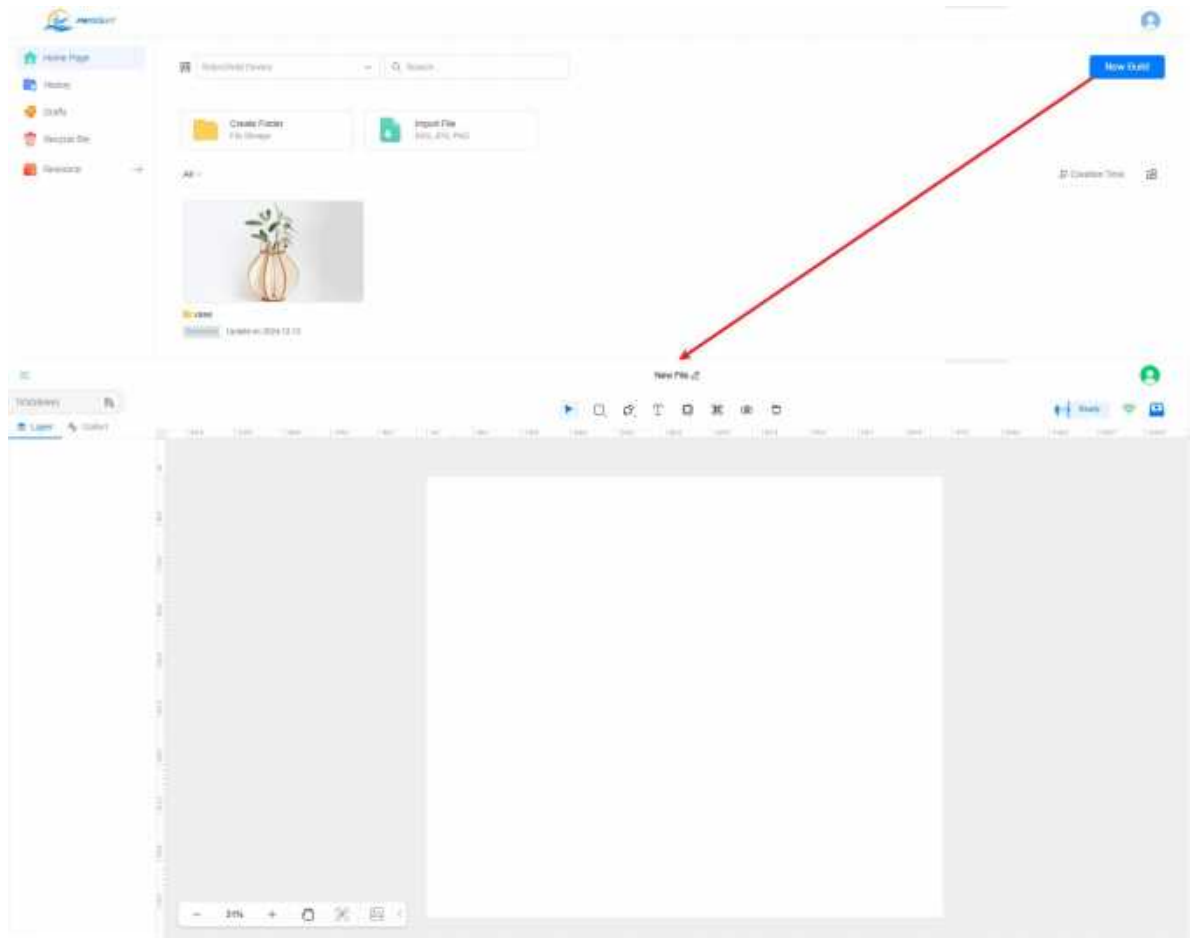

13.4.3 Import the design

Click on the homepage [Import File] to operate, and currently supports SVG, JPG, and PNG file formats.

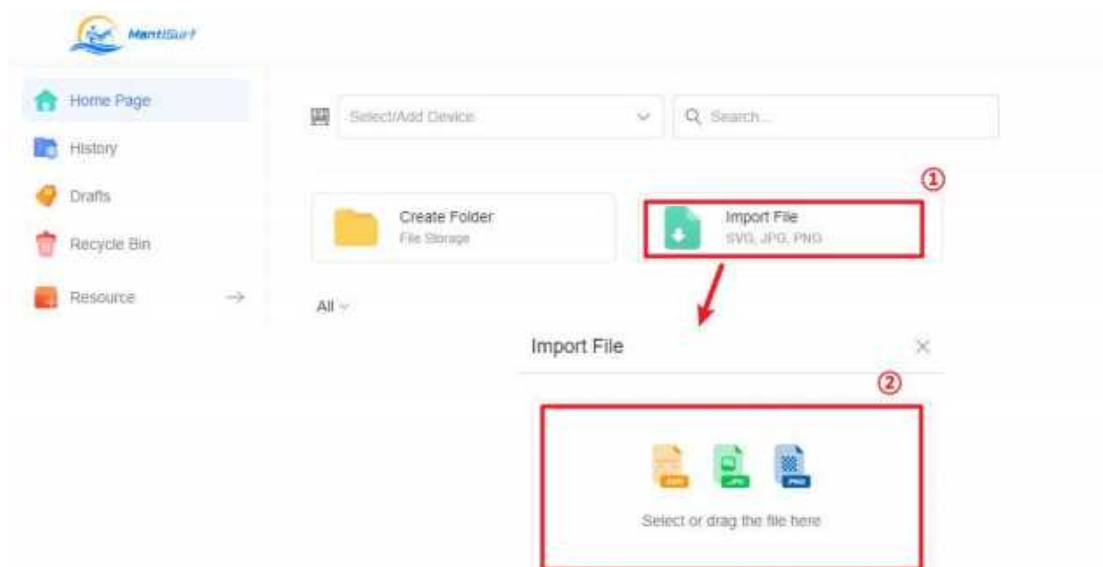

13.5 Drawing operations

Double-click the design you want to use or click the "Print" button below the design drawing, and you will be redirected to the design drawing editing interface, as shown in the following figure:

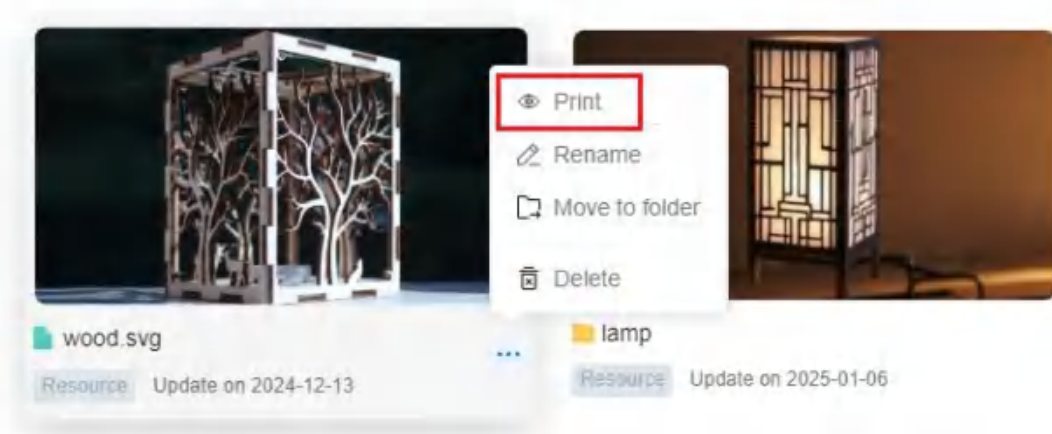

Once enter the canvas, you will see the operation interface,. The page consists of an operation bar, file name, material selection, layer, icon library, editing toolbar, processing status bar, typesetting toolbar, parameter operation bar, canvas management bar, and format operation bar.

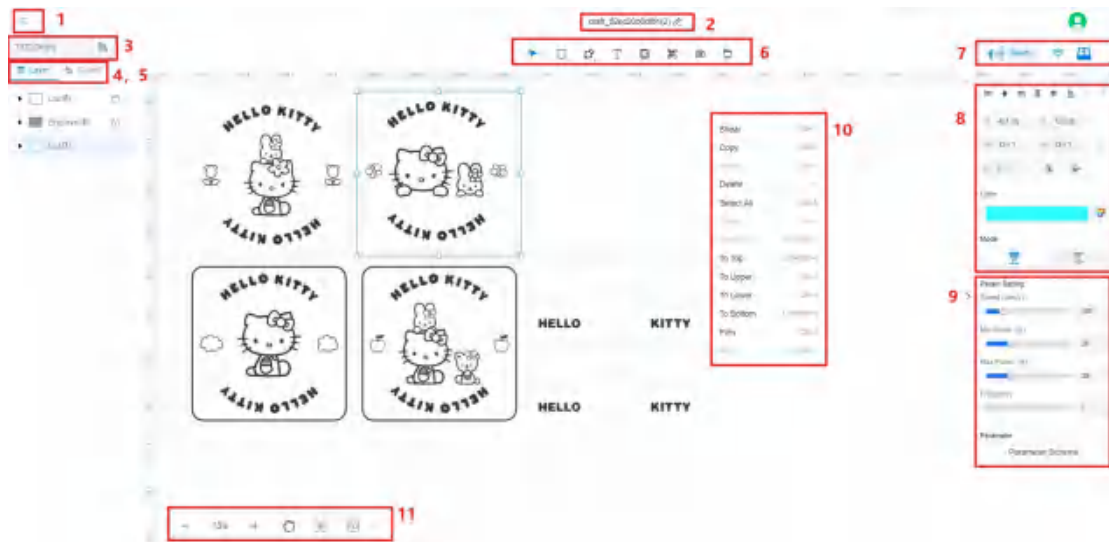

Operation bar: including returning to personal center, file, editing, setting, and help functions, as shown in the figure.

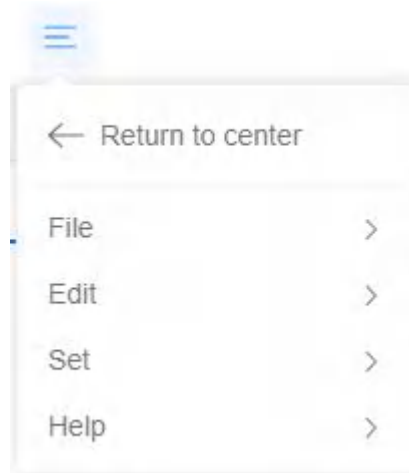

1.1 Files: You can freely import SVG and pictures into the files of the current design, or save the files of the current design, or enter the resource community to obtain the drawing files.

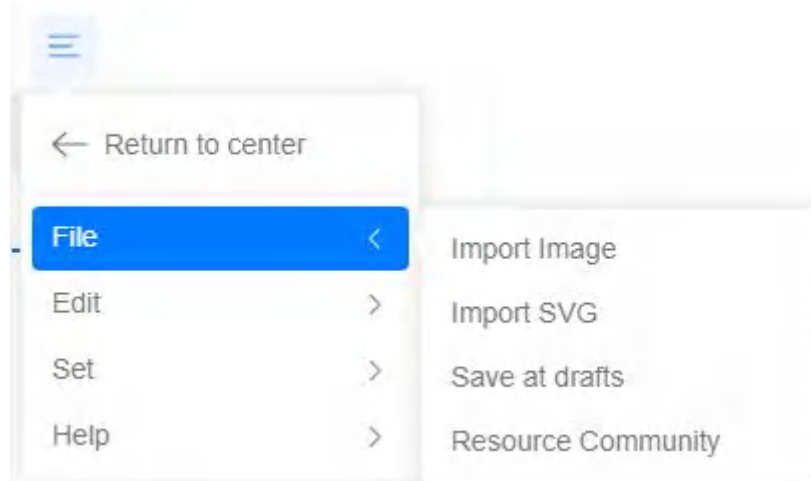

1.2 Editing: Ordinary operations can be performed on canvas design files.

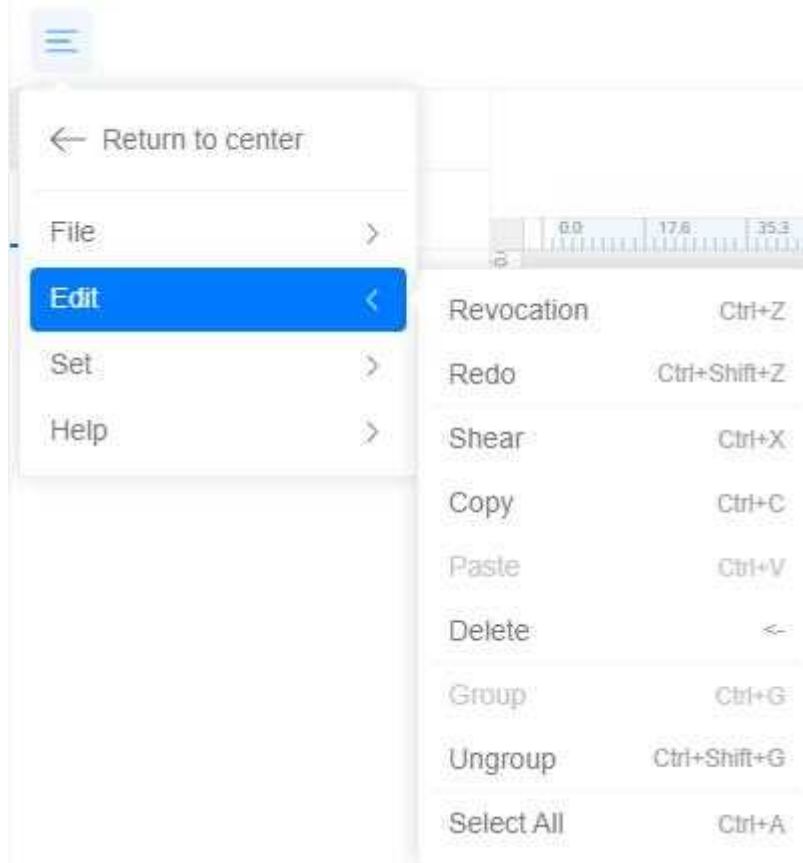

1.3 Settings: There are two functions here: [Basic Settings] and [Camera Correction].

1.3.1 Click [Basic Settings] to set the canvas unit, size, and camera origin.

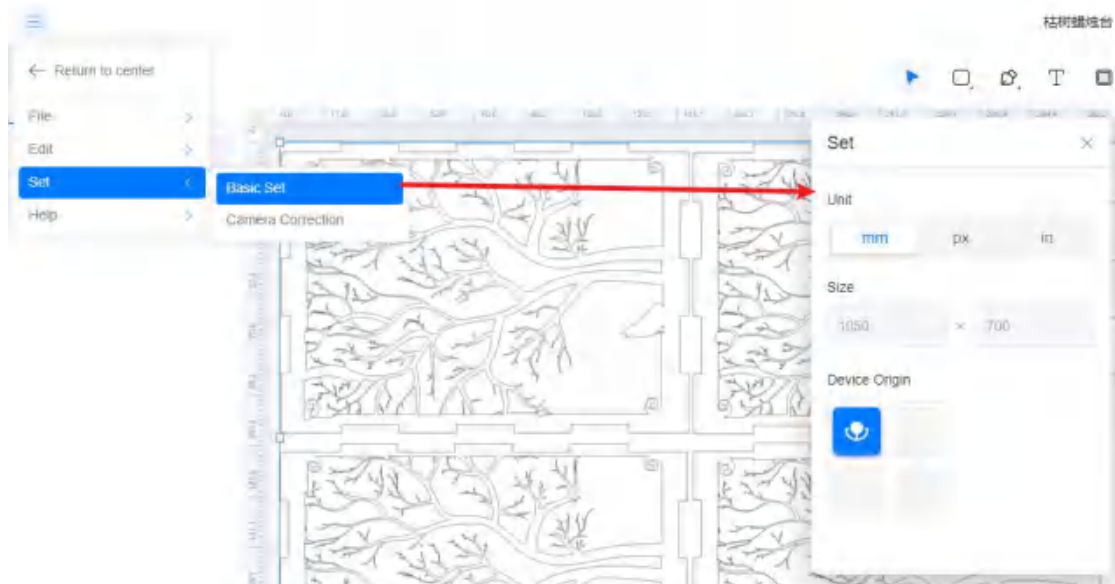

1.3.2 Click [Camera Correction] to correct according to the prompts, while the device remains online and "idle".

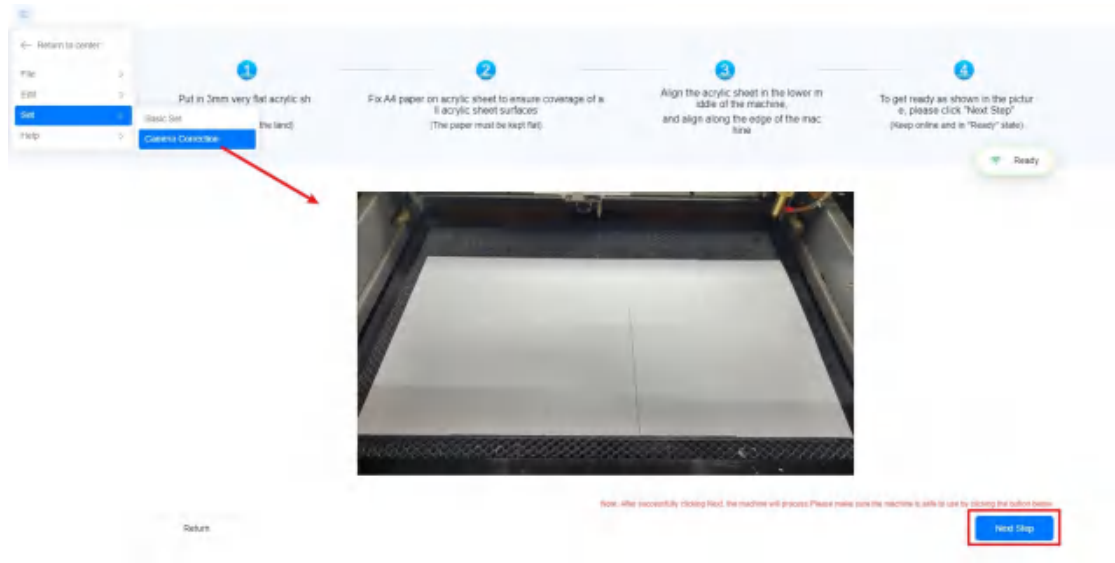

1.4 Help: If user has any problem during operation, enter the help center to get solutions.

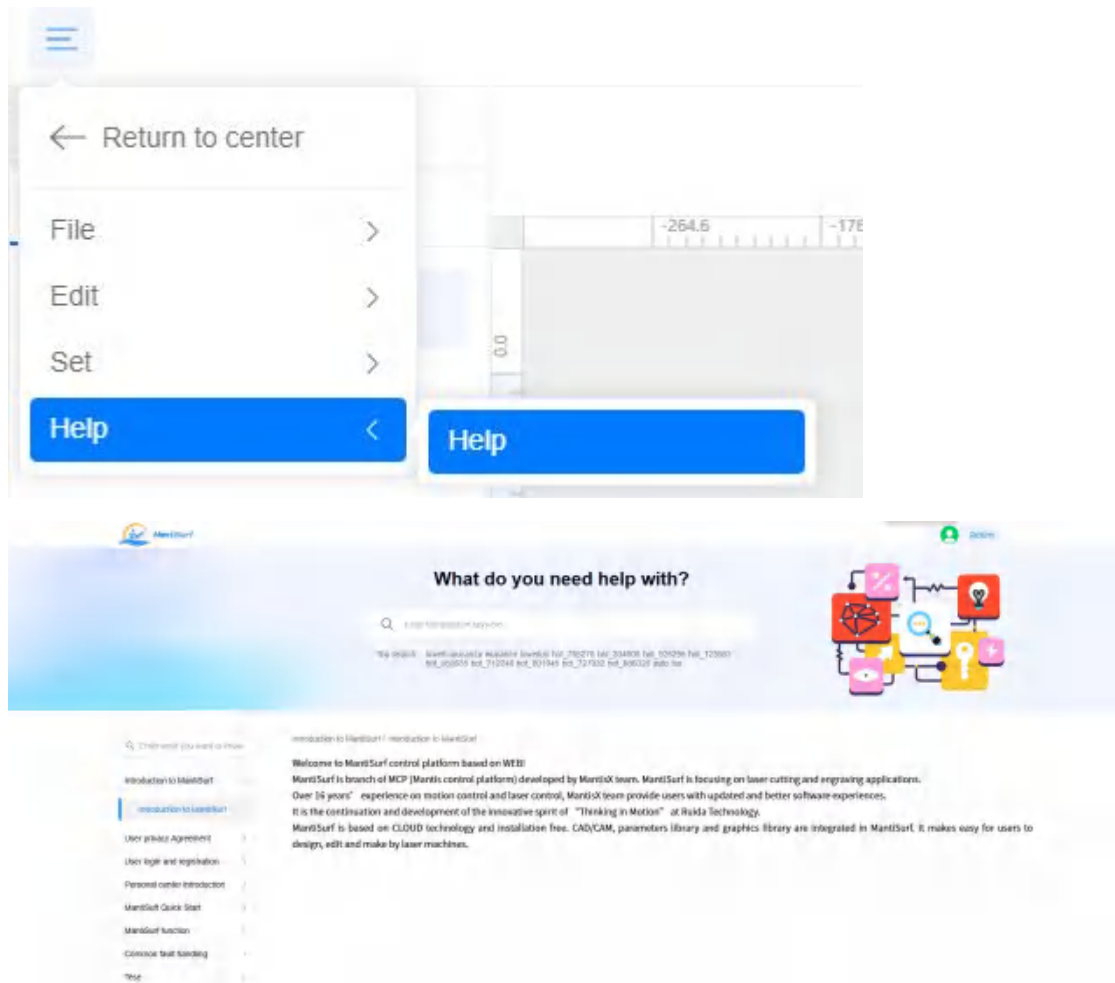

File Name: You can rename the name of the design file for recognition and

search after saving.

Material selection: This function is to select and correct the machine format background map according to the different thickness of the material, so this function must need to have the machine format background map in the case, and the material is also divided into official materials and self-added materials, as shown in the figure.

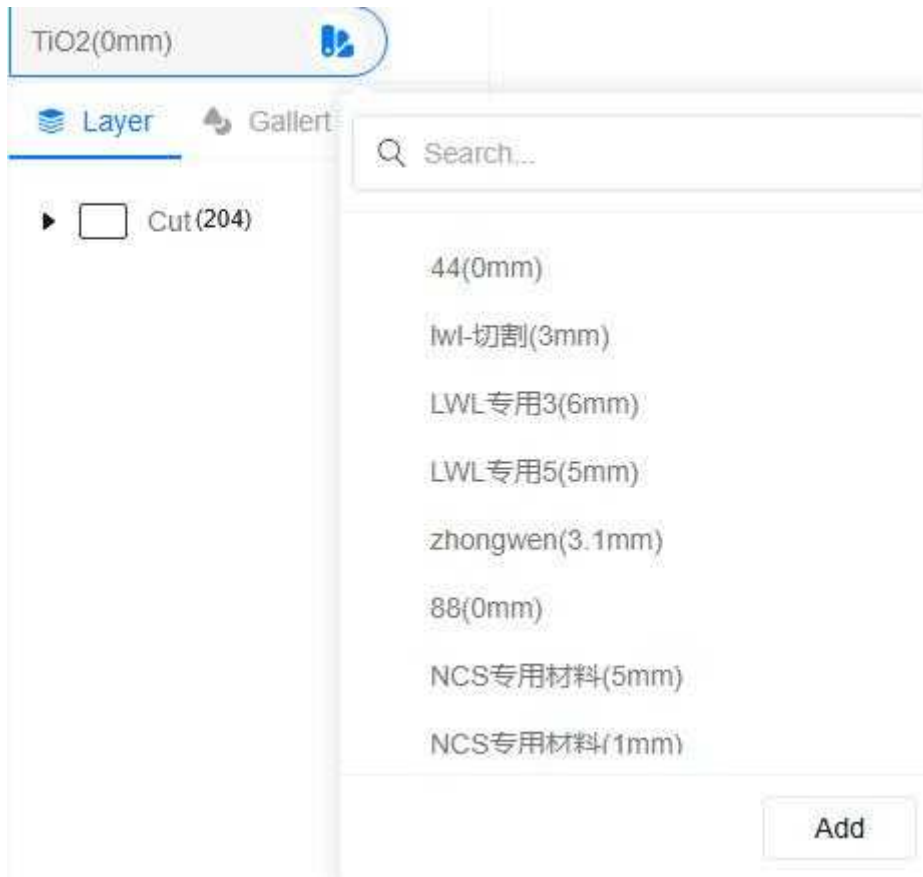

Layers: The design is grouped by color, different colors represent different layers, the layer can be dragged up and down to change the processing order of the layer, and can hide and show whether the layer is processed, and the layer can also be locked and cannot be operated, as shown in the figure.

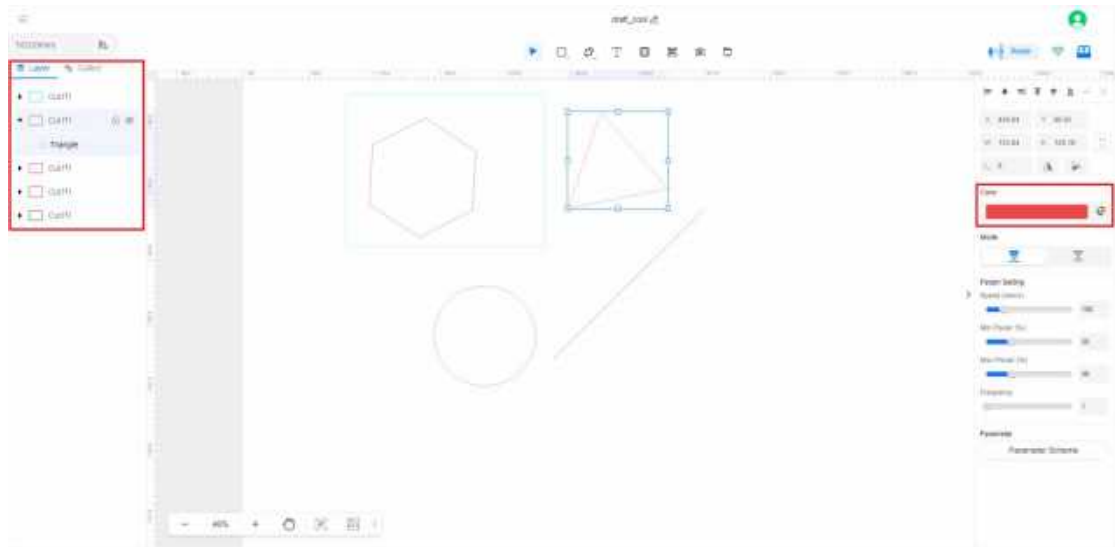

Icon Library: There are all kinds of official free icons, which can be searched by type and content, and click on the number next to the type to display all the icons under the type. Click on the icon to use it, as shown in the image.

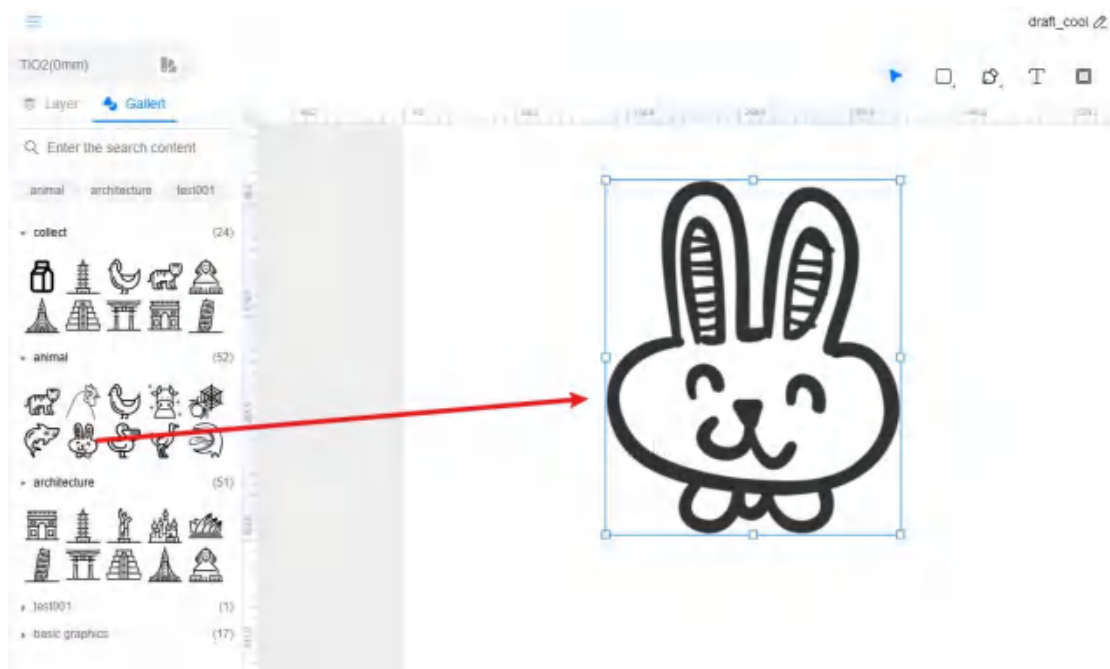

Editing toolbar:

The main functions of this software can be done by executing the command options in the toolbar, and executing the toolbar command is the most basic way to operate; The toolbar includes 8 functions: view, graphic, path, text, background outline, QR code, photo, and parameter library.

6.1 View: The view tool includes the selection tool and the move view, which is the selection tool by default; Move the view to freely drag the position of the format, and the shortcut key Esc can exit immediately.

6.2 Graphics: Click and select the shape you want to insert into the canvas, the function contains some common and commonly used graphics, as shown in the figure.

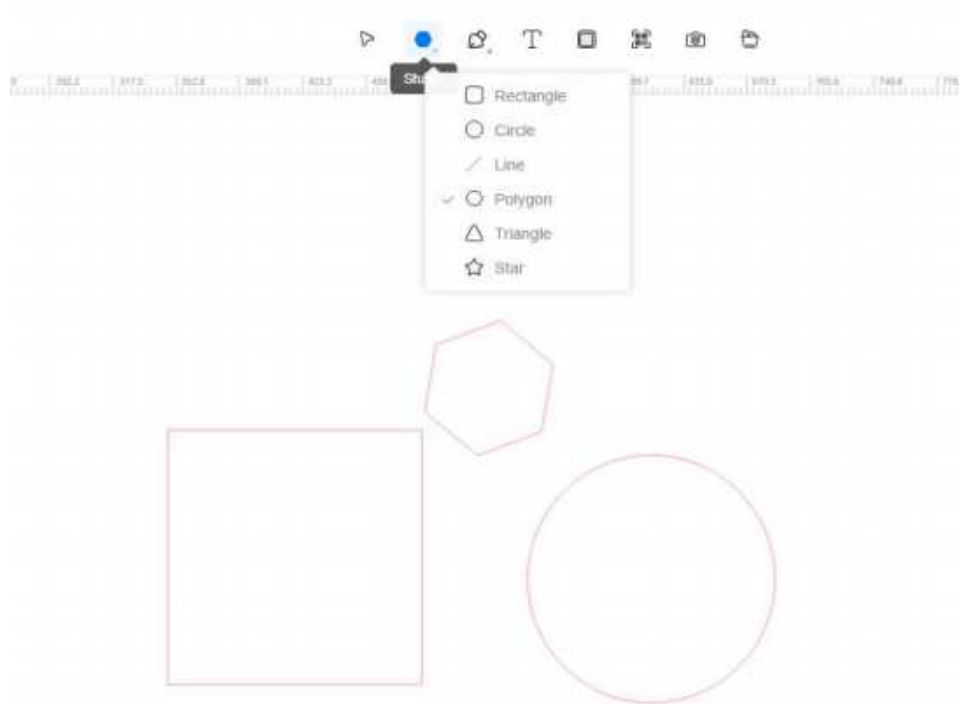

6.3 Path: There are two different ways to select the path of pen and graffiti, and press Esc to end the drawing after the drawing is completed, as shown in the figure.

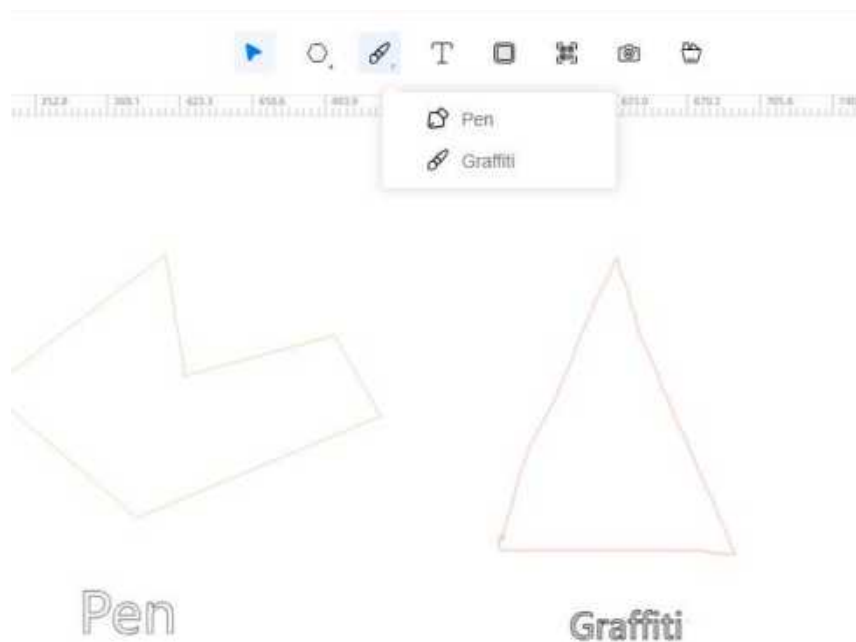

6.4 Text: Click anywhere in the drawing area to pop up the text input dialog box, you can change the text content, direction, color, font, size, style, alignment, processing mode and processing parameters after entering text on the page.



6.5 Background outline: When there is a machine background map, you can make a frame to extract the outline of the pattern in the frame.

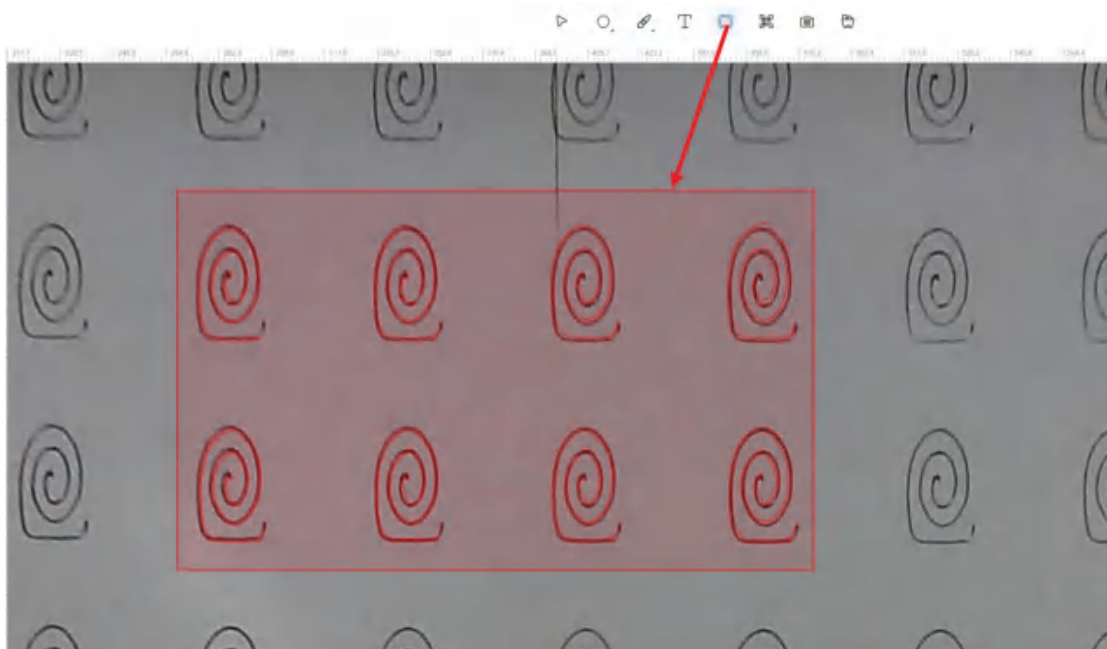

6.6 QR code: The tool identifies the QR code of the official material parameter library on the background map of the machine, and can directly obtain the corresponding material thickness and processing parameter values.

6.7 Take a picture: Take a picture of the machine as the background picture, and the machine must be connected to use the tool.

6.8 Parameter library: Here provides the corresponding cutting and engraving processing parameter schemes for different machine types, which are divided into custom and manufacturer's. Customized parameter schemes can be imported and exported as CSV files as shown in the image.

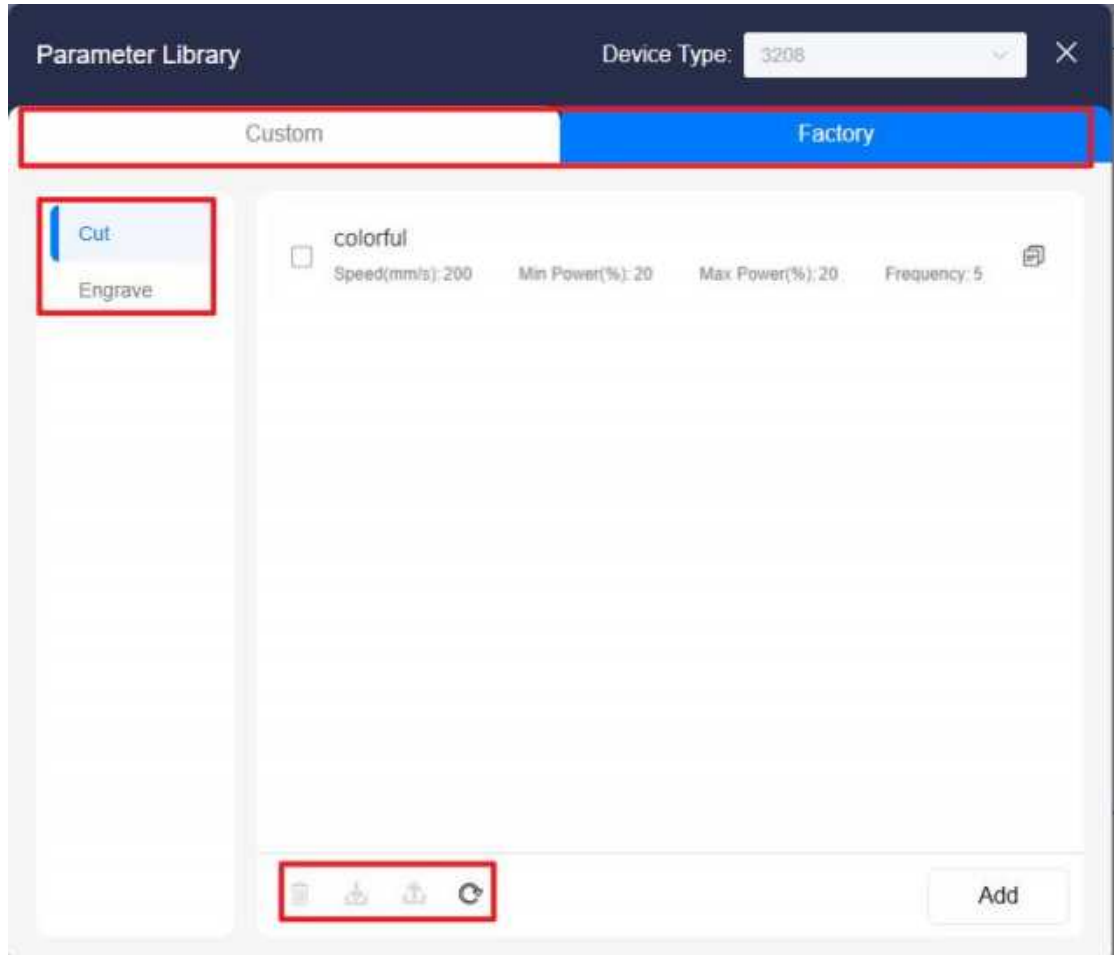

Processing status bar:

here is the processing status, wifi signal, processing button, after the machine is successfully connected, the processing status will show the status of the current machine, such as idle, processing, fault and other states; WiFi signal prompt, if the device is connected, the strength of the wifi signal will be displayed, otherwise there will be a prompt of offline status, such as the offline state of the device, you need to connect according to the prompt.

The idle status is shown below: the wifi signal prompt will show the strength of the current signal.

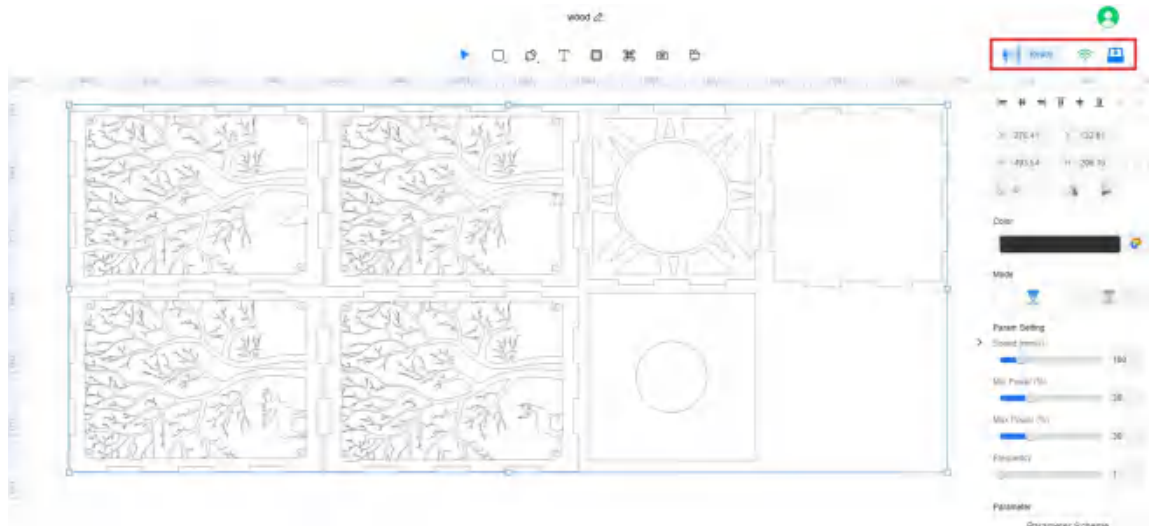

The offline status is as follows: when the machine is offline, the machine status bar will be offline, and an offline prompt box will pop up below with connection help.



The processing status is as follows: in the processing status, the machine status bar will display the processing, and the processing progress bar will pop up at the bottom to display the real-time progress of the processing.

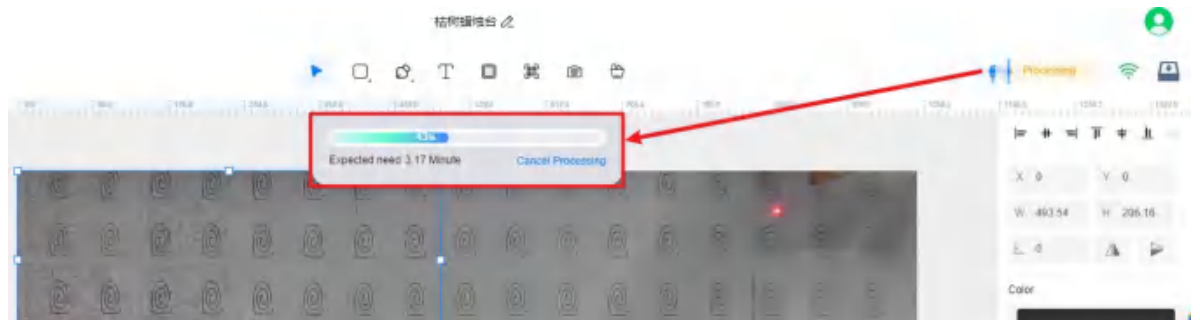

The fault status is as follows: when the fault status is in the fault state, the machine status bar will display the fault, and the prompt box will show the specific fault reason, click cancel to cancel the processing and end the fault state.

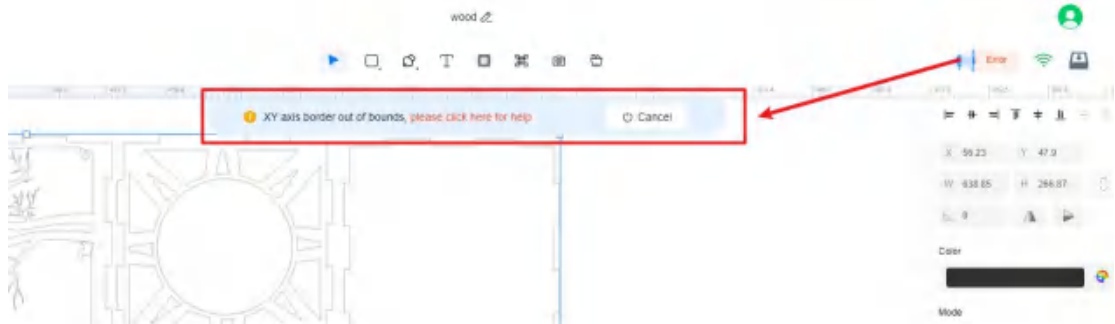

Typesetting toolbar: Common function options are reflected in the form of command buttons, including direction, position, coordinates, width and length, and color.

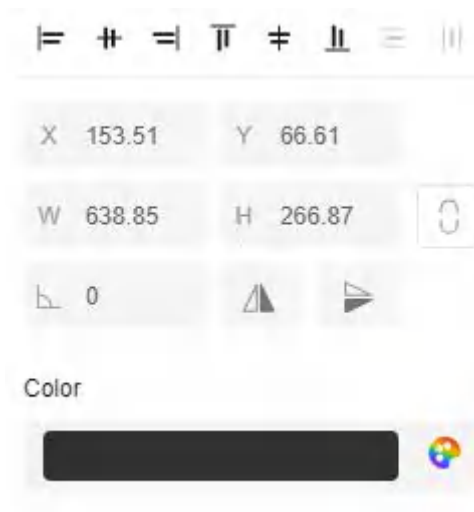

Parameter Operation Bar: [Parameter Setting] and [Parameter Scheme] operations on the control panel.

9.1 Parameter setting: The processing mode is divided into cutting and engraving, and different color groups can be given to design different processing parameters.

9.2 Parameter scheme: You can click on the parameter scheme and select the parameter scheme suitable for use in the parameter library, as shown in the figure. **Note: When you select a parameter scheme, the parameters of the graphics of the same color layer are the same.**



Canvas management bar: Right-click anywhere on the canvas to pop up the following menu, you can manage the images and layers of the images on the canvas according to your needs.

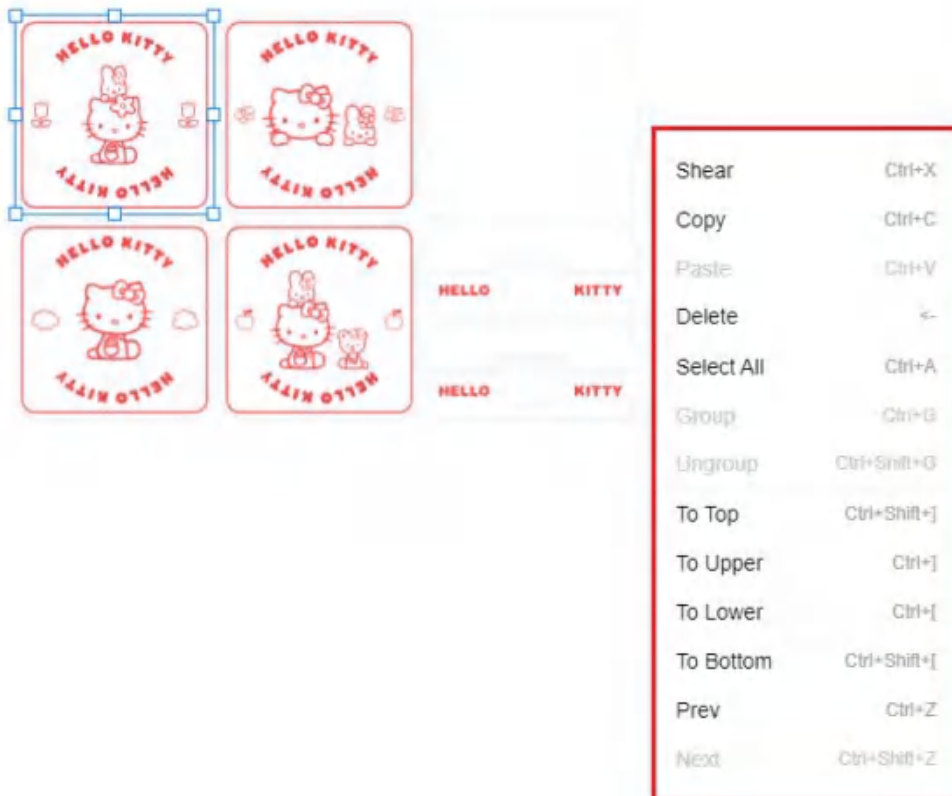

Canvas zoom bar: zoom in or out of the canvas, or fit the canvas to the screen; The maximum magnification of the canvas is 2000%, after selecting 200%, you can press [+] in the lower left to continue to zoom in on the canvas, and you can also move the view (shortcut keys hold the space bar) to hide the ruler and background image.

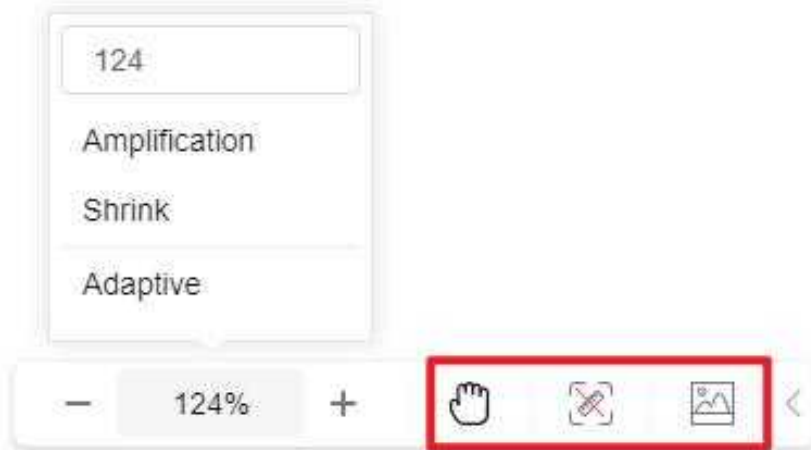

13.6 The menu bar on the left is introduced

13.6.1 Home

After successfully logging in, it will automatically jump to the home page, where all your design drawings are stored, including the purchase of official and self-uploaded content, and the home page functions include: **device management, resource search box, create folders, import files, file resource area, personal center and other functions, to achieve simplified operation.**

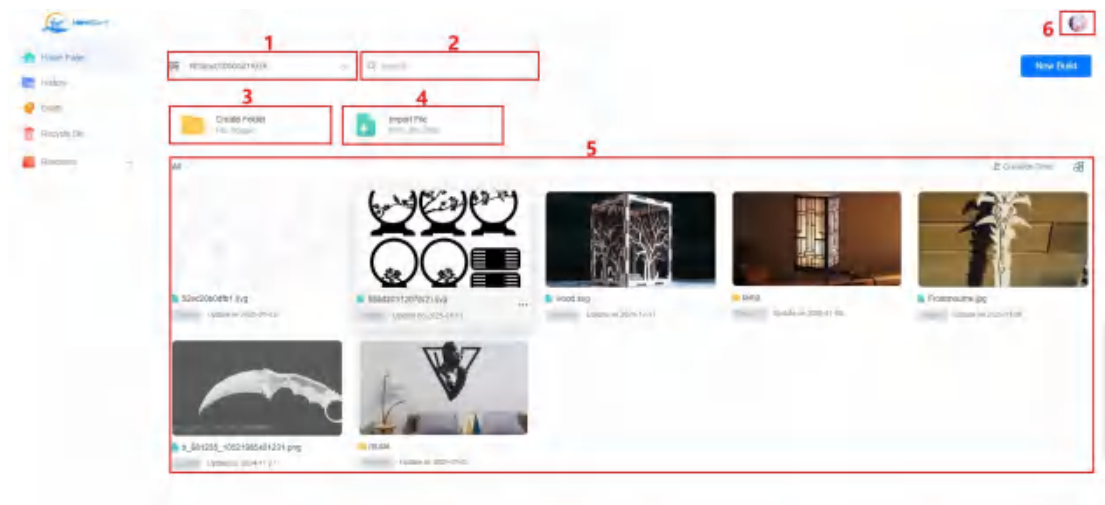

1.1 Device management: Here you can freely choose the device you want to use according to the device number, and you can add, delete and check the device number. This is shown in the figure below.

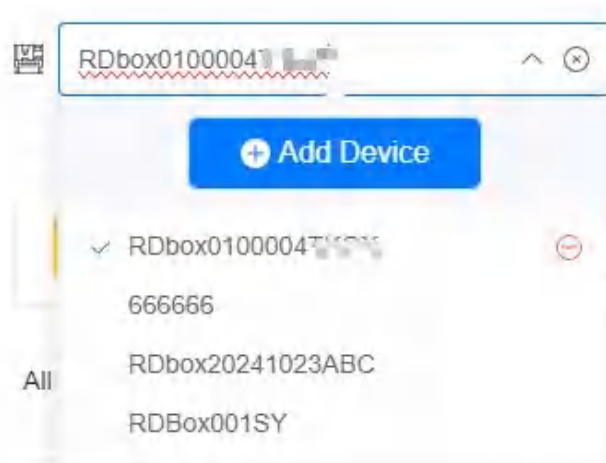

1.2 Resource search box: You can perform a fuzzy search based on the name of the file.

1.3 Create Folder: Click Create Folder and enter the folder name to create an empty folder.

1.4 Import file: You can import the design drawings you need to use, currently support SVG, JPG, PNG formats.

1.5 File Resource Area: This is where you can import your own design drawings and purchased resources.

1.5.1 Resources: Official blueprints purchased from the resource community are displayed as resources.

1.5.2 Original: The design drawings imported by yourself are displayed as original.

1.5.3 Folders: Folders and files can be distinguished by the icon next to the file name.

1.5.4 File Type Filtering: Here you can filter according to the design drawing and folder, as shown in the figure.

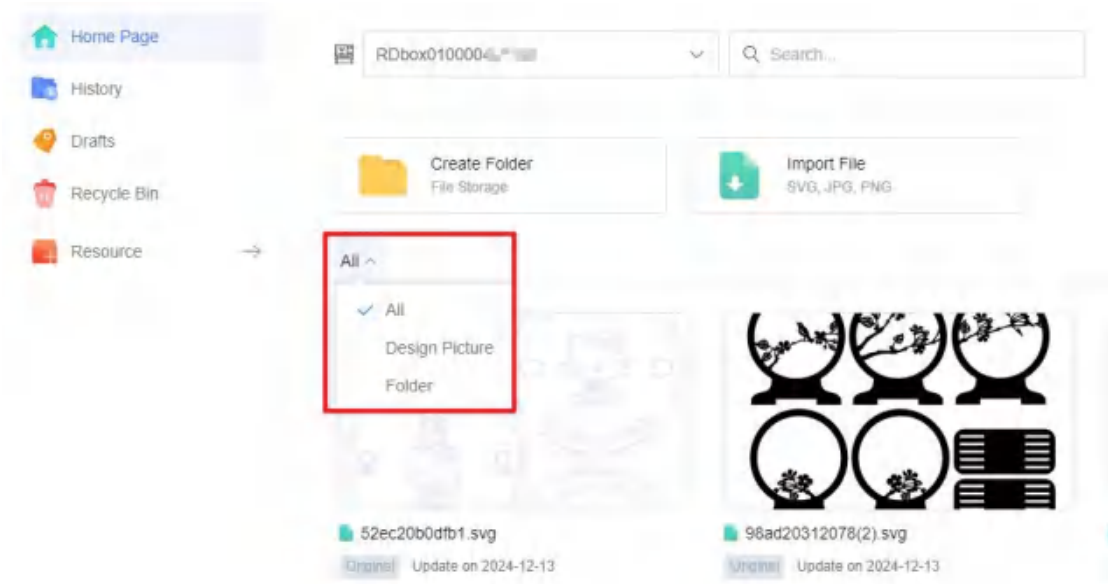

1.5.5 Sorting: Sort files in many different ways, as shown in the figure.

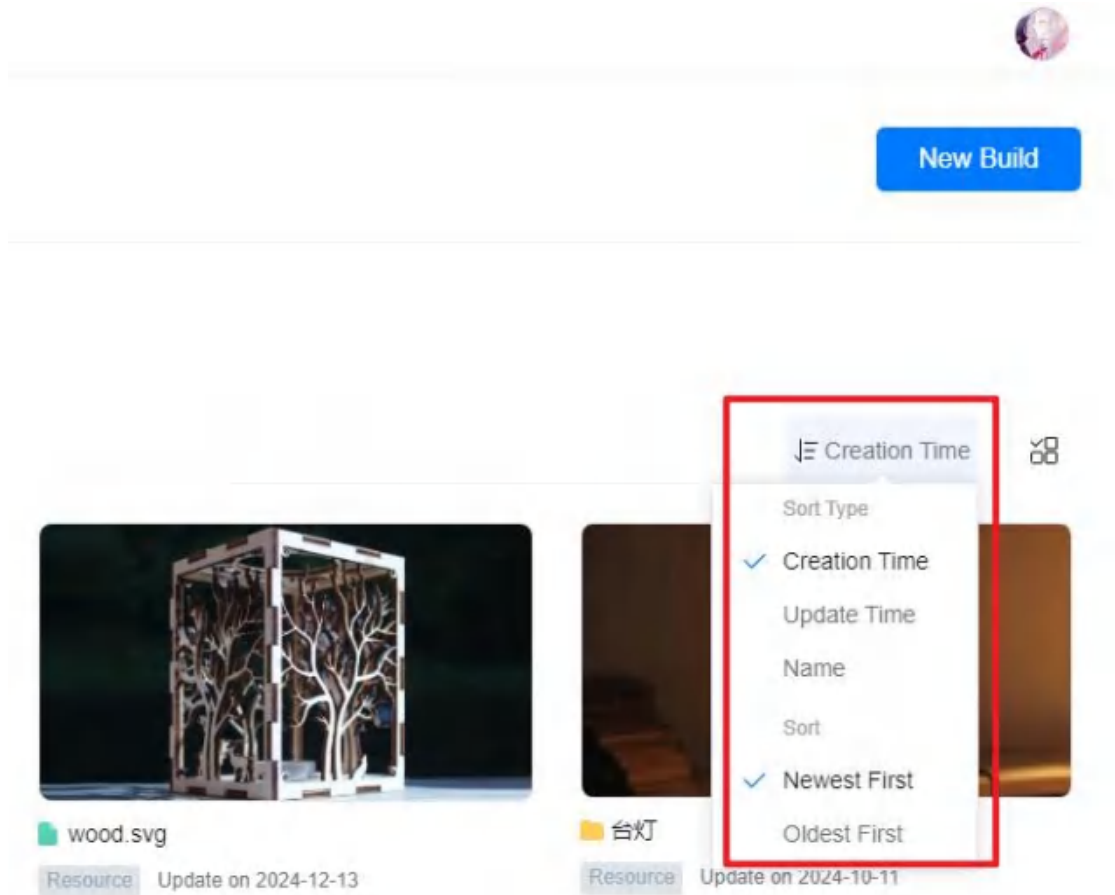

1.5.6 Batch operation: You can delete and move folders in batches, as shown in the figure.

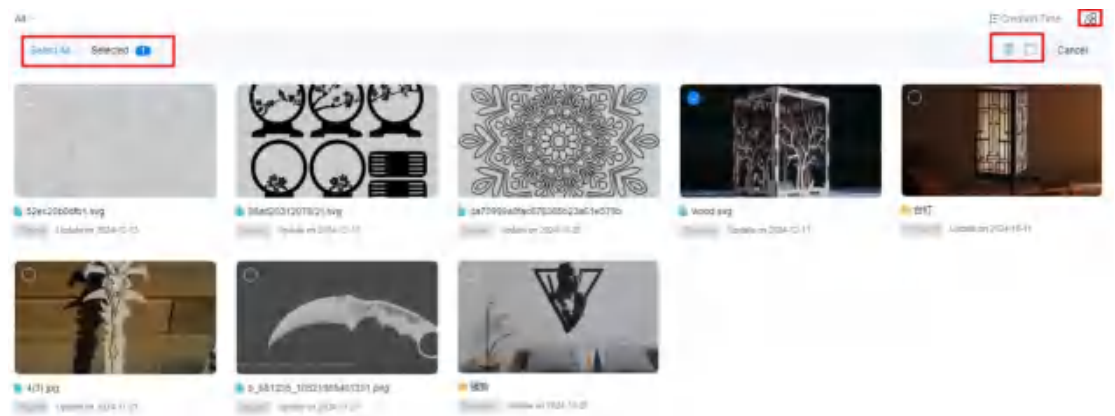

1.5.7 File operation: Here you can print, rename, move, delete and other operations on the file, as shown in the figure.

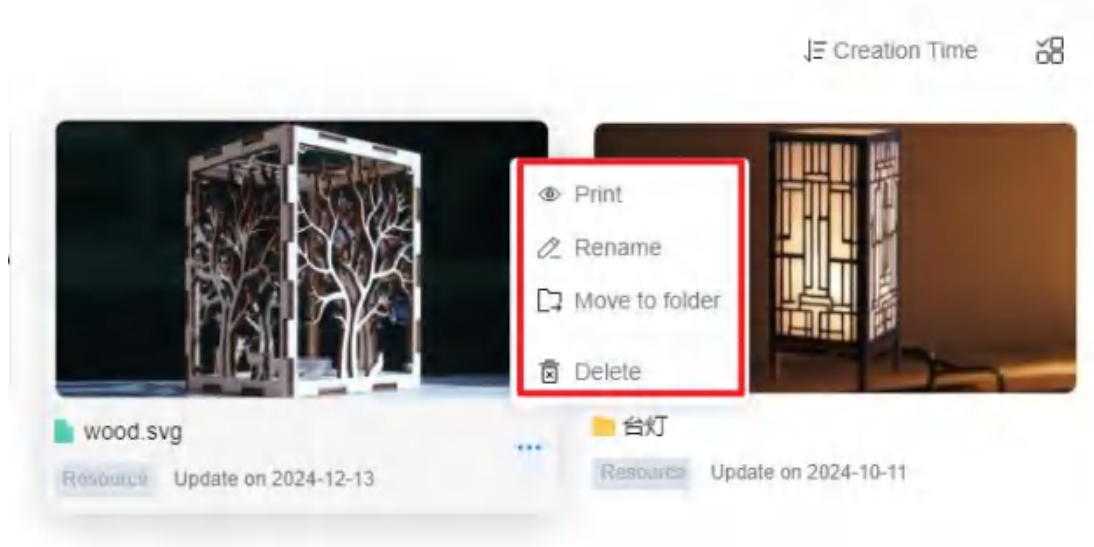

1.6 Personal Center: This place displays the user's avatar, account name and email information, and can be used for account settings, language conversion, help center, and logout operations.

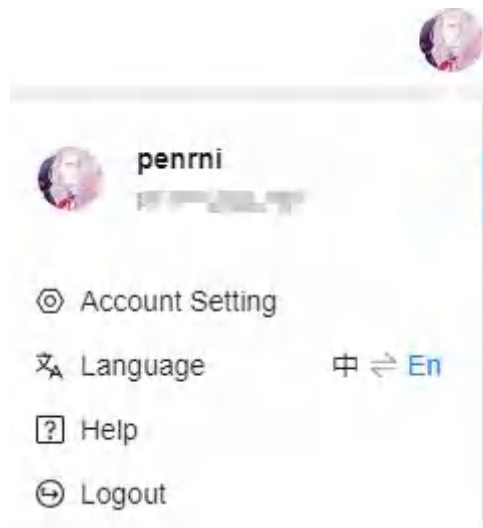

13.6.2 Processing History

Click [Processing History] on the left operation bar to view all processed operation history.

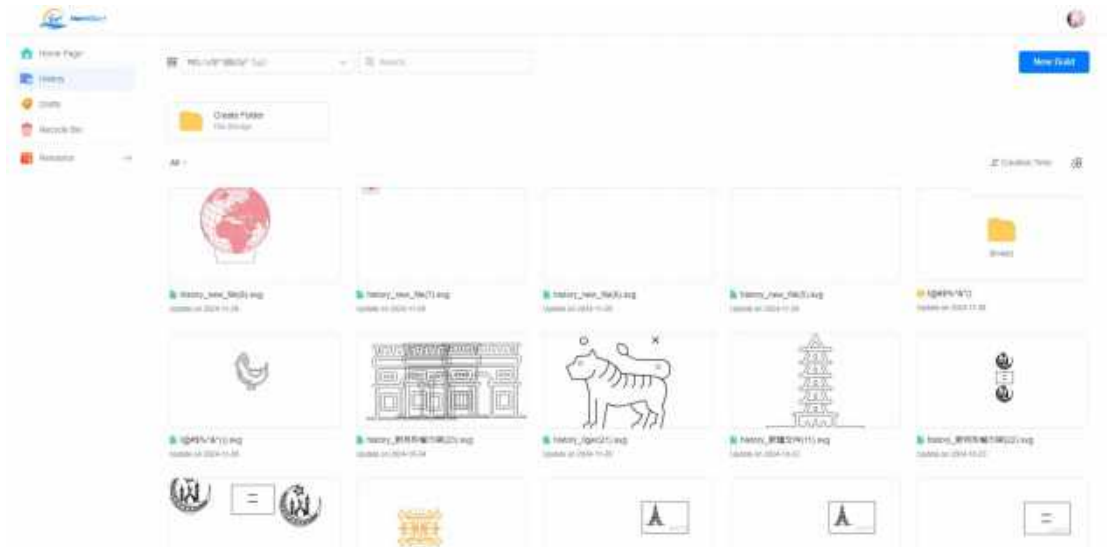

13.6.3 Draft box

The draft box is used to store the content of the drawings you edit and saved, and you can view it by clicking the [Draft Box].

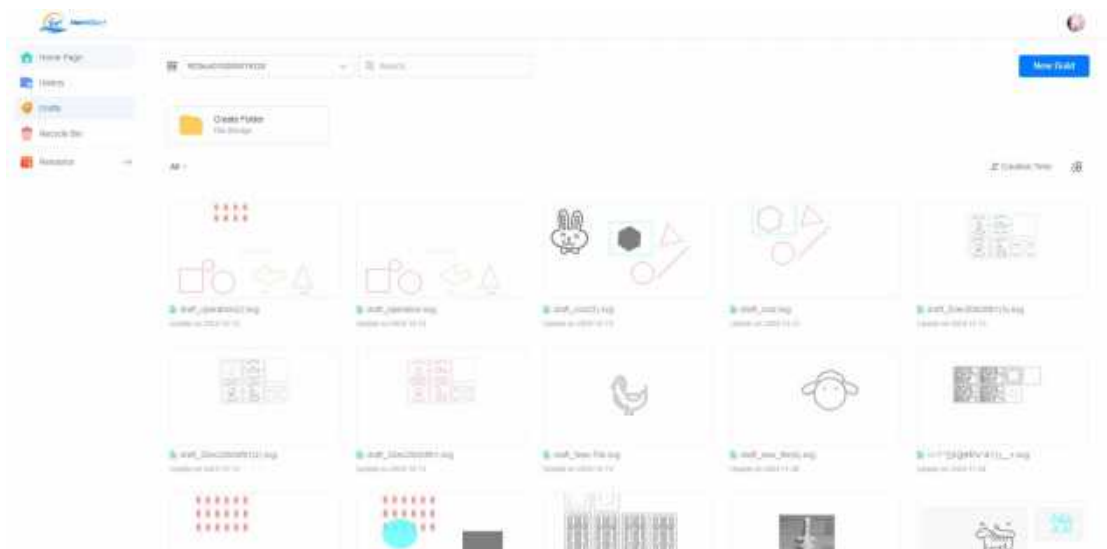

13.6.4 Recycle Bin

The recycle bin is mainly used to store the documents temporarily deleted by the user, which can restore the accidentally deleted files from the recycle bin, or completely delete the deleted files placed in the recycle bin, and the files placed in the recycle bin will be automatically deleted after 30 days.

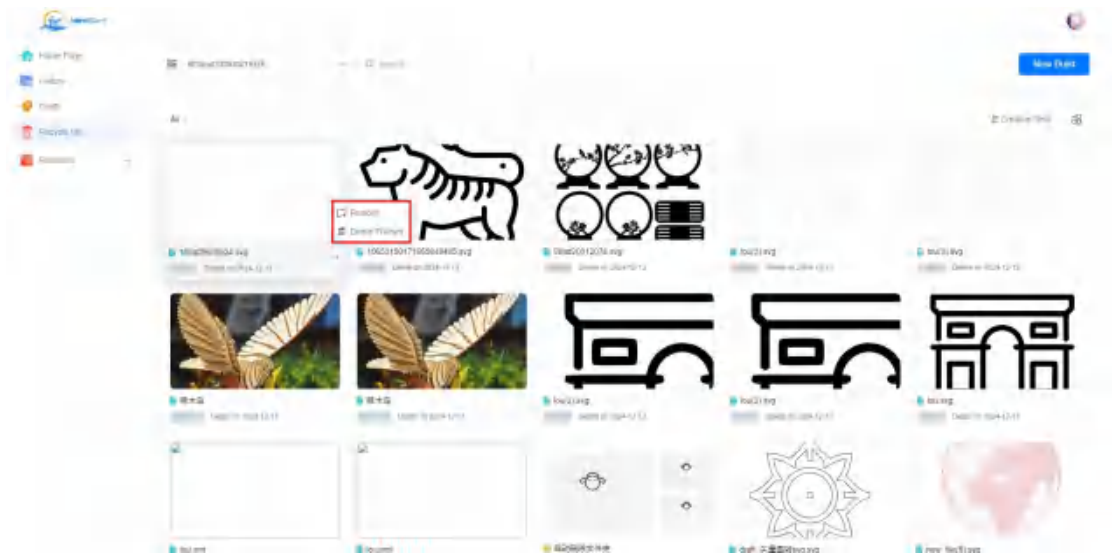

13.6.5 Resource Community

What is shown here is the official design drawing, as shown in the figure, users can purchase according to their needs, this page shows the resource classification, resource map display, and resource price.

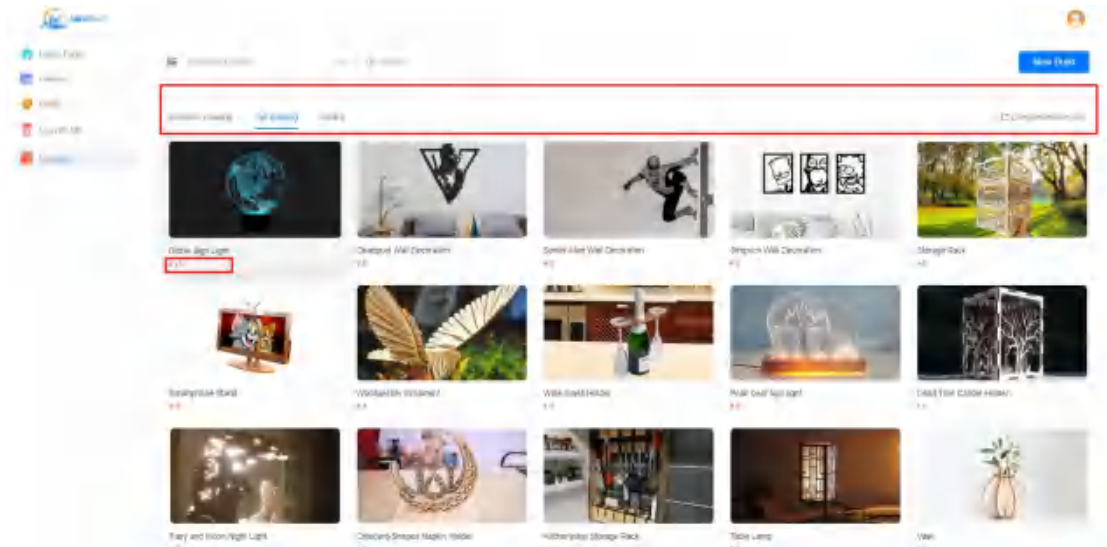

1. Resource classification: Different design drawings can be viewed according to the resource classification.
2. Resource diagram display: display the finished product style of the design drawing, click to enter the design drawing to view the details, as shown in the figure.

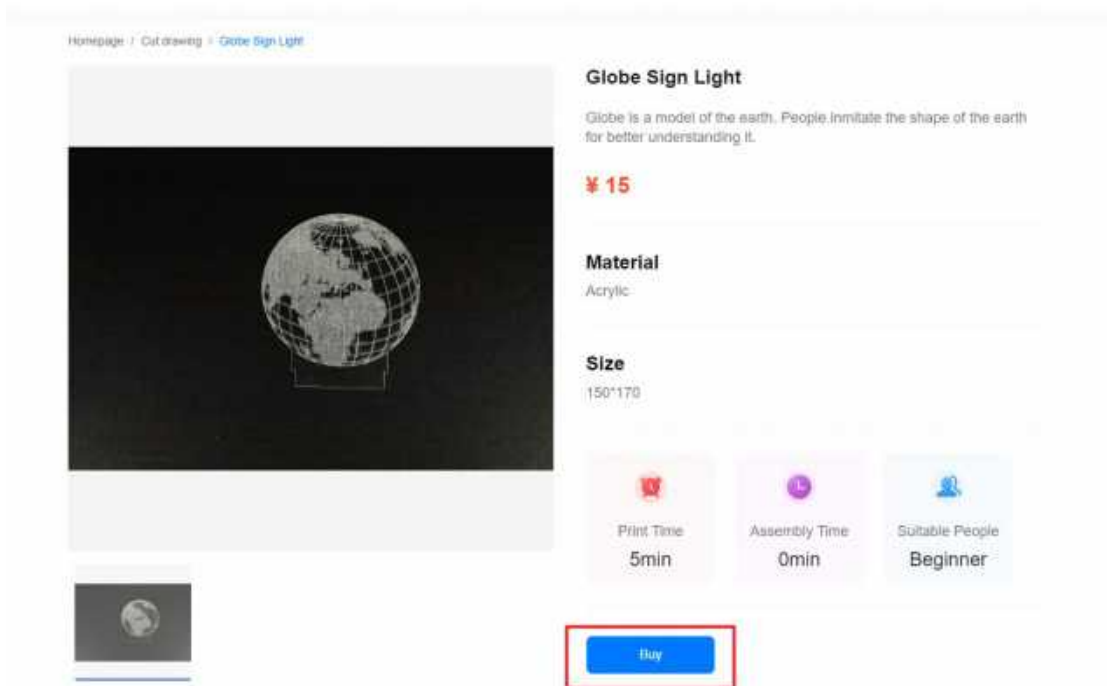

3. If the price of the resource map is displayed as 0, it is a free resource, otherwise you need to pay the corresponding price to get the resource, and you can view it on the homepage after purchase.

Thank you for your selection of our production!

All the copyright of this manual is owned by Ruida technology. Any person or company can not copy upload and send the manual without Ruida's permission.

Content will be revised or modified. We will not send message to every users.

If there are any question or suggestion about our products and manuals, please tells us.

Tel: (086)0755-26066687

Fax: (086)0755-26982287

Adress : 202-203,B-Block,Technology Building, 1057 Nanhai Avenue, Nanshan District, SHENZHEN, CHINA

Website: www.rd-ac.com

