

# User Manual

## BGM400 Series Barrier Gate

Date: April 2026

Doc Version: 1.2

English

Thank you for choosing our product. Please read the instructions carefully before operation. Follow these instructions to ensure that the product is functioning properly. The images shown in this manual are for illustrative purposes only.

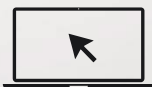

For further details, please visit our Company's website  
[www.zkteco.com](http://www.zkteco.com).

## TABLE OF CONTENTS

<b>1</b>	<b>OVERVIEW</b> .....	<b>3</b>
1.1	Basic Features .....	3
1.2	Application Field .....	3
<b>2</b>	<b>TECHNICAL PARAMETERS AND BASIC FUNCTIONS</b> .....	<b>4</b>
2.1	Technical Parameters .....	4
2.2	Basic Functions .....	5
2.3	Test Technical Parameter.....	5
<b>3</b>	<b>APPEARANCE</b> .....	<b>7</b>
<b>4</b>	<b>CONTROL PANEL WIRING INSTRUCTIONS</b> .....	<b>8</b>
<b>5</b>	<b>PRODUCT FUNCTION AND OPERATION DESCRIPTION</b> .....	<b>9</b>
5.1	Check the Gate before Powering On .....	9
5.2	Gate Power-Up Self-Test Process .....	9
5.3	Mainboard Parameter Setting Process.....	9
5.4	Parameter Settings Description.....	11
5.5	Remote Control Settings.....	18
5.5.1	Remote Control Pairing .....	18
5.5.2	Cleaning the Remote Control .....	19
<b>6</b>	<b>MOVEMENT DESCRIPTION</b> .....	<b>20</b>
6.1	Dimensions .....	20
6.2	Horizontal and Vertical Angle Adjustment of Boom Arm (Mechanical Adjustment) .....	20
6.3	Direction Interchange of the Boom Arm .....	22
6.4	Spring Adjustment.....	23
<b>7</b>	<b>TROUBLESHOOTING</b> .....	<b>24</b>
<b>8</b>	<b>PACKING LIST</b> .....	<b>26</b>
<b>9</b>	<b>AFTER-SALES SERVICE</b> .....	<b>26</b>

# 1 Overview

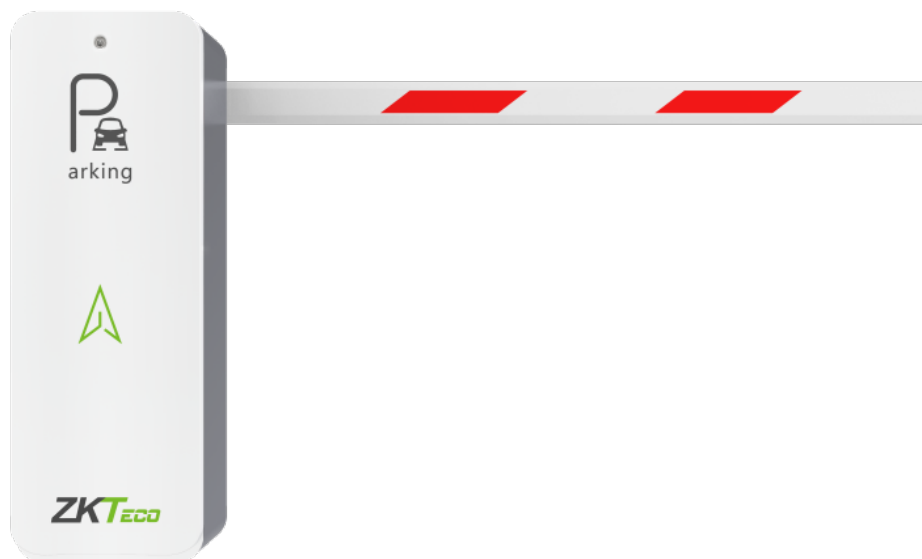

## 1.1 Basic Features

- Adopting DC brushless motor drive and servo control, the running speed of the gate is infinitely adjustable, and the gate pole runs smoothly with little noise.
- The stopper lever is smooth, and the jittering amplitude of the gate lever is small (can be adjusted to the best state by pressing the key).
- Available 24V uninterruptible power supply and solar power supply, even if the power outage can also run smoothly.
- All digital setting operation, can also realize the whole network digital management.

## 1.2 Application Field

Management of vehicles at parking lot entrances and exits, as well as at entrances and exits of residential communities, businesses, public institutions, and park

## 2 Technical Parameters and Basic Functions

### 2.1 Technical Parameters

<b>Device Model</b>	BGM400L/R
<b>Dimension of Main Unit</b>	330*265*980mm
<b>Packing Size</b>	430*375*1100mm
<b>Working Environment Parameters</b>	<b>Power Supply:</b> AC220V/110V±10% 50/60HZ.
	<b>Working Voltage:</b> DC24V, 10A.
	<b>Rated Power:</b> 160W.
	<b>Operating Temperature of Movement and Controller:</b> -30°C or 75°C.
	<b>Working Humidity:</b> ≤90%RH.
	<b>Remote Control Frequency:</b> 433MHZ, learning code.
	<b>Remote Control Distance:</b> ≤ 30 meters.
<b>Take-Off And Landing Lever Time</b>	Boom length 6 meters ≥ 4.5 ≥ 3 meters, starting speed 1.5 to 6 seconds can be infinitely adjustable.
<b>Movement</b>	Movement for the three-stage gear deceleration plus four-boom structure.
	Motor winding material: pure copper.
	The long and short swing arm and connecting boom are made of cast steel.
	The integrated mold design incorporates a three-stage gear reducer and a four-linkage mechanism, ensuring straightforward and efficient movement, as well as convenient installation and maintenance.
	The main shaft is #40mm in diameter, made of 45# steel, with galvanized surface.
	Balance spring ( φ 5.5/ φ 6.5)* φ 40*420, according to the length of the boom optional side-by-side two. (Adapted according to different pole lengths.)
<b>Gate Lever</b>	Octagonal telescopic pole, cross-section size, big pole 86*44*1.0mm, small pole 80*37*1.0mm.

	Large octagonal two-rail, cross-section size 100*45*1.0mm.
<b>Enclosure</b>	Q235 cold galvanized steel plate, steel plate thickness T=1.5mm, surface powder coating, 200°C high temperature baking for 20min.
<b>Net Weight</b>	40KG
<b>Protection Grade</b>	IP54
<b>Leakage Current</b>	Leakage current ≤ 2mA.
<b>Insulation Resistance</b>	Under normal conditions, the insulation resistance of motor power line ≥ 1MΩ (megohm).
<b>Grounding Resistance</b>	AC work grounding resistance ≤ 0.1Ω.
<b>MCBF</b>	≥2,000,000 times of opening and closing the gate.

## 2.2 Basic Functions

1. Switch gate angle at  $90^{\circ} \pm 2^{\circ}$ .
2. Equipped with standard switch inputs for on, off, stop interface, enabling remote control via a small program on a mobile phone.
3. Automatic monitoring ensures adjustable anti-smash bar strength and sensitive time without requiring additional external gate facilities.
4. Controller timeout protection: automatically stops the gate if abnormal operation exceeds the specified start and stop time.
5. Gate control through wireless remote, wired buttons for the gate open, close, stop.
6. Features traffic light and breathing system light functions.
7. Self-learning and fleet counting function capabilities.
8. Rebound function in case of obstruction.
9. Time-delay automatic function.

## 2.3 Test Technical Parameter

Test Item	Test Requirement
<b>Limit</b>	Mechanical and electronic limits are firmly installed, and the induction device is normal.
<b>Lift Boom Operation</b>	The take-off and landing boom runs smoothly, without shaking, interference and abnormal sound.

Test Item	Test Requirement
<b>Position Boom Level</b>	The lifting boom is perpendicular to the horizontal, and the falling boom is parallel to the horizontal, without skew.
<b>Mainboard Function</b>	Control board parameters are set properly.
<b>Spring</b>	The operation performance is good, no difference.
<b>Remote Control Unit</b>	The remote controller is sensitive, and the distance test meets $\leq 30$ meters.
<b>Insulation</b>	Motor power line insulation resistance $\geq 1M\Omega$ (megohm).

### 3 Appearance

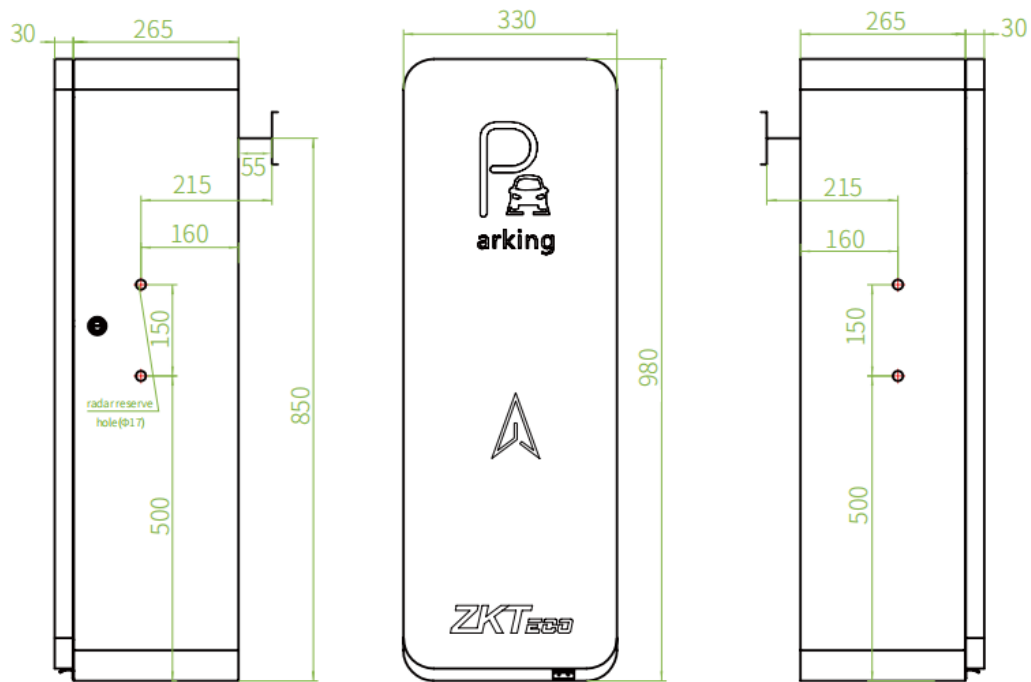

#### Left And Right Direction Definitions:

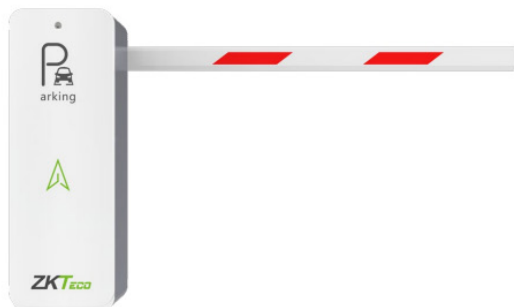

L: The chassis on the left, the boom on the right

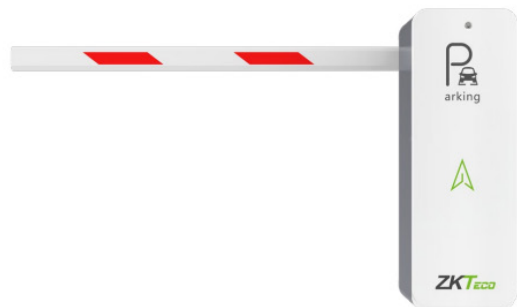

R: The chassis on the right, the boom on the left

## 4 Control Panel Wiring Instructions

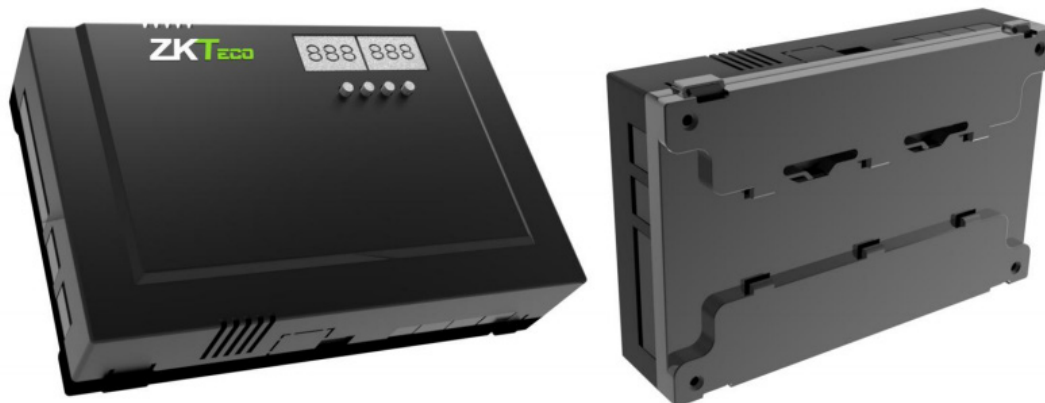

Front View

Back View

### Control Panel Wiring Diagram:

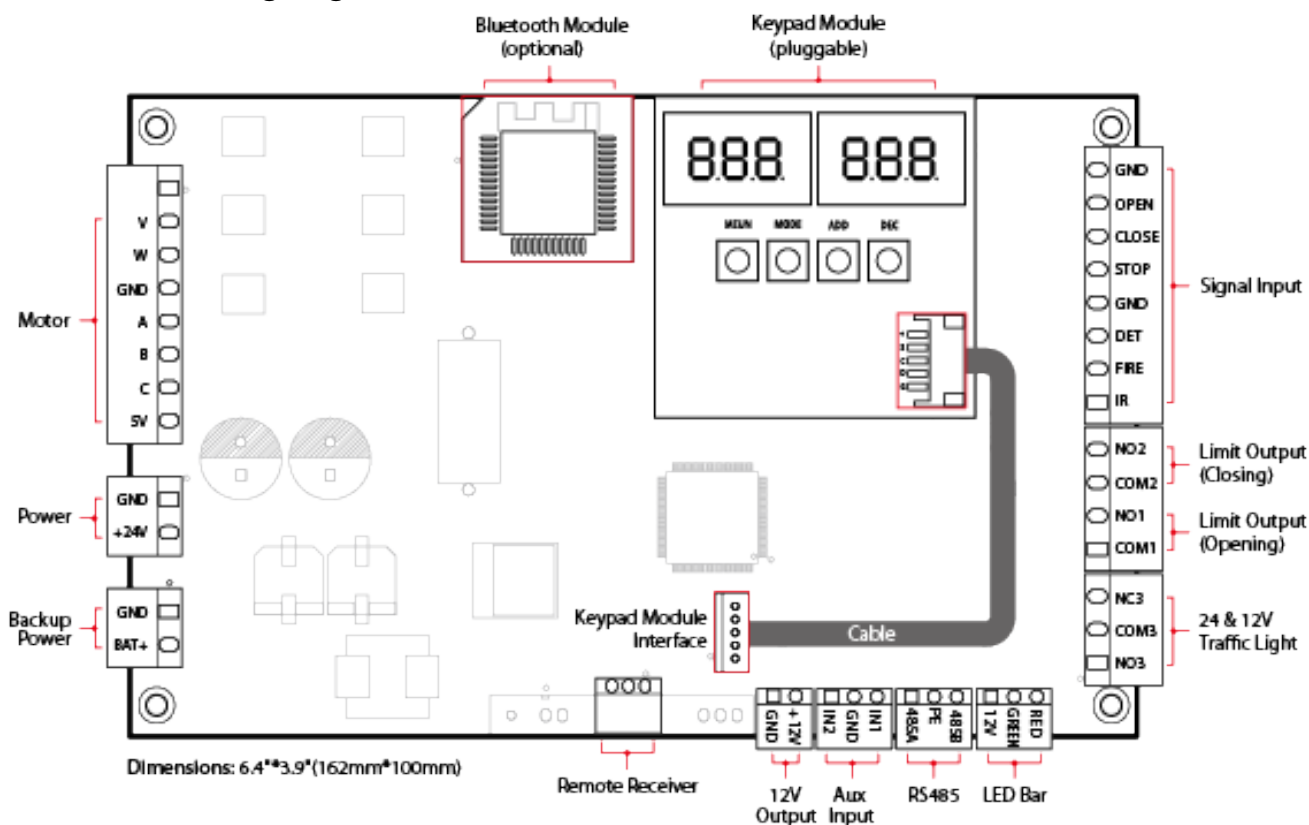

## 5 Product Function and Operation Description

### 5.1 Check the Gate before Powering On

1. Check that the gate is connected to a 24V/10A DC power supply.
2. Check whether the polarity of all external wiring (power line, motor line, ground sensing line) is correct, and the connection is firm and stable. Incorrect wiring polarity may result in gate malfunction. If the motor forward and reverse line is reversed, the digital display on the main board (normally, the display increases when the gate is opened, and the number decreases when the gate is closed), as well as the markings on the control handle or the control switch will be the opposite of the actual action of the gate.

### 5.2 Gate Power-Up Self-Test Process

1. After powering on the gate, the digital tube on the controller's main board displays the corresponding status. The main board and motor undergo an initial self-test to synchronize. It is essential to manually press the "on" and "off" buttons on the main board for the self-test to learn the travel limits. The main board automatically memorizes the motor travel, enabling subsequent power restoration to be controlled only via the remote or license plate recognition camera with "on" or "off" commands.
2. The gate's self-test involves learning the two fixed limit positions of the motor. Ensure that the self-test learning trip, when open, exceeds 90°, and when closed, is less than 0°. This establishes a baseline for subsequent horizontal and vertical adjustments.

**Note:** The first installation, the first power on, you must use the mainboard "on" and "off" button complete self-check to learn the opening and closing travel.

### 5.3 Mainboard Parameter Setting Process

● **Key Description**

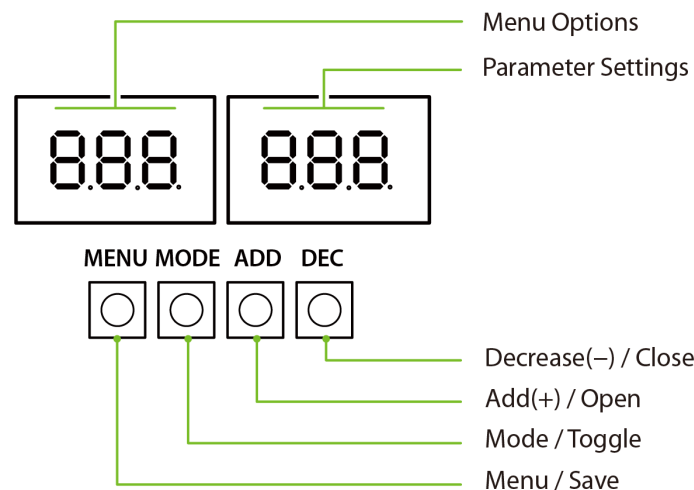

<b>Menu / Save</b>	Go to the Menu Options / Save the Parameter Settings.
<b>Mode / Toggle</b>	Stop the boom arm / Switch menu options and parameter settings.
<b>Add(+)/ Open</b>	Open the barrier gate, go to the next menu option, or add one when modifying the value.
<b>Decrease(-) / Close</b>	Close the barrier gate, return to the previous menu option, or subtract one when modifying the value.

**Note:** Digital tube display, the left side shows menu options, the right side shows parameter settings.

● **Operating Procedure**

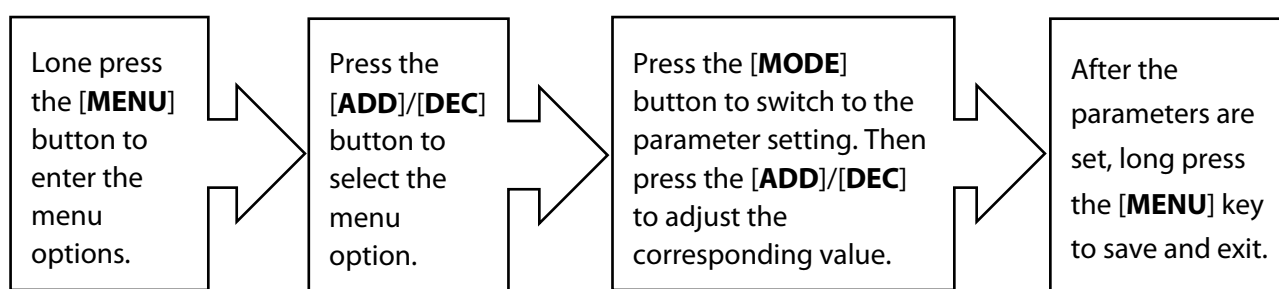

For example, set the value of the closing speed to 22 (03E.\*\*\*, default value 16, valid values 10~30).

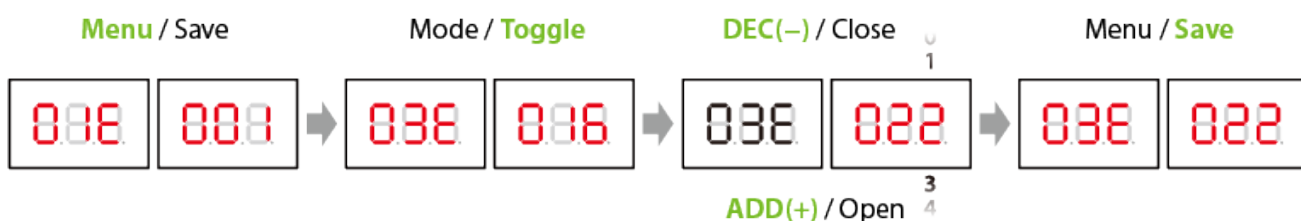

## 5.4 Parameter Settings Description

Items	Description	Default
<b>01E.***</b>	<p><b><u>Display Mode</u></b></p> <ul style="list-style-type: none"> <li>● <b>01E.000:</b> Displays the status of the boom arm and the encoder value</li> <li><b>1F0.**:</b> Opening position</li> <li><b>2F0.**:</b> Closing position</li> <li><b>5F0.**:</b> Opening</li> <li><b>6F0.**:</b> Closing</li> <li><b>4F0.**:</b> In the pause</li> <li><b>0F0.**:</b> Not self-tested</li> <li><b>7F0.**:</b> Not stop at the open/close limit</li> <li>● <b>01E.001:</b> Displays the status of the boom arm and the current input signal (displays the status as "*F*.**")</li> <li>● <b>01E.002:</b> Test mode</li> <li>● <b>01E.003:</b> Number of boom openings</li> <li>● <b>01E.004:</b> Version Information</li> <li>● <b>01E.005:</b> Displays the hidden menus (The menus after item 13 are hidden)</li> </ul>	<b>01E.001</b>
<b>02E.***</b>	<p><b><u>Boom Arm Opening Speed</u></b></p> <p>Set the Boom Arm Opening Speed to open the gate. The larger the number is set, the faster the speed. The Boom Arm Opening Speed value can be set between 10 to 30 and the default value is 16.</p>	<b>02E.016</b>
<b>03E.***</b>	<p><b><u>Boom Arm Closing Speed</u></b></p> <p>Set the Boom Arm Closing Speed to close the gate. The larger the number is set, the faster the speed. The Boom Arm Closing Speed value can be set between 10 to 30 and the default value is 16.</p>	<b>03E.016</b>

<p><b>04E.***</b></p>	<p><b><u>Open Limit Adjustment</u></b></p> <p>Long press (1 to open the gate, 2 to close the gate)</p> <p>Excessive rotation beyond the limit position can cause the boom arm to fail to lock and become easily movable.</p>	<p><b>04E.004</b></p>
<p><b>05E.***</b></p>	<p><b><u>Close Limit Adjustment</u></b></p> <p>Long press (1 to open the gate, 2 to close the gate)</p> <p>Excessive rotation beyond the limit position can cause the boom arm to fail to lock and become easily movable.</p>	<p><b>05E.004</b></p>
<p><b>06E.***</b></p>	<p><b><u>No-vehicle Automatic Closing Time</u></b></p> <p>Set the time to automatically close the boom arm after successful verification but no vehicle passes, the larger the number, the longer it takes to close the boom arm. If the "Boom Arm Opening Memory" function is turned on, the gate will not be closed even after the no-vehicle automatic closing time. The Boom Arm Opening Memory function takes priority. It can be set between 5s and 60s, the default value is 0. When set to "0", this function is turned off.</p>	<p><b>06E.000</b></p>
<p><b>07E.***</b></p>	<p><b><u>Boom Arm Opening Memory</u></b></p> <ul style="list-style-type: none"> <li>● <b>07E.000:</b> Close</li> <li>● <b>07E.001:</b> Open</li> </ul> <p>When more than two legal access signals are given at the same time (including the same direction and the opposite direction), the system will remember all pass requests and complete each pass in turn.</p> <p>Memory opening is only available for use with gate opening signal port and ground-sensing radar.</p>	<p><b>07E.000</b></p>
<p><b>08E.***</b></p>	<p><b><u>Motor Rotation Direction</u></b></p> <ul style="list-style-type: none"> <li>● <b>08E.000:</b> Forward</li> <li>● <b>08E.001:</b> Reverse</li> </ul> <p>Set the rotation direction of the left and right mechanism boom arm. When restoring the factory settings, this parameter will not be restored to the default value. Modifying this parameter will trigger a restart.</p>	<p><b>08E.000</b></p>

<p><b>09E.***</b></p>	<p><b><u>Reset</u></b></p> <ul style="list-style-type: none"> <li>● <b>09E.000:</b> -Normal</li> <li>● <b>09E.001:</b> Reset</li> <li>● <b>09E.002:</b> Restore Bluetooth initial password: 12345678</li> </ul> <p>Select <b>[09E.001]</b> will restore the default factory setting.</p>	<p><b>09E.000</b></p>
<p><b>10*.***</b></p>	<p><b><u>Remote Control Pairing</u></b></p> <ul style="list-style-type: none"> <li>● <b>100.***:</b> Normal</li> <li>● <b>101.***:</b> Add (pair by pressing any remote control button)</li> <li>● <b>102.***:</b> Clear</li> </ul> <p>Currently, it supports a maximum of 500 remote controls.</p> <p><b>Note:</b> The third digit is adjusted by pressing [+/-] to add or clear remote control.</p> <p>In normal mode, the last three digits shows the number of remotes that have been paired with the current device.</p> <p>When restoring the factory settings, the remote control will not be cleared if remote control type has not changed.</p>	<p><b>100.000</b></p>
<p><b>11E.***</b></p>	<p><b><u>Sensitivity of the Boom Arm Bouncing</u></b></p> <p>Sets the bounce sensitivity of the boom arm when it encounters an obstacle. The higher the value, the lower the sensitivity, and the longer it will take to bounce. When set to 100, this function will be turned off and the boom arm will not bounce when it encounters an obstacle. It can be set between 20 and 100, the default value is 50.</p>	<p><b>11E.050</b></p>

12E.***	<p><b><u>Boom Arm Type</u></b></p> <ul style="list-style-type: none"> <li>● <b>12E.001:</b> Foam boom</li> <li>● <b>12E.002:</b> Straight boom</li> <li>● <b>12E.003:</b> Telescopic boom</li> <li>● <b>12E.004:</b> Grille boom</li> <li>● <b>12E.005:</b> Folding boom</li> <li>● <b>12E.006:</b> Advertising boom</li> <li>● <b>12E.007:</b> Test boom/No boom</li> </ul>	12E.000
13E.***	<p><b><u>Boom Arm Length</u></b></p> <p>1~6m</p>	13E.000
14E.***	<p><b><u>Boom Arm Opening Brake Stroke</u></b></p> <p>The larger the number, the greater the deceleration stroke.</p> <p>The deceleration stroke is too large, which may cause the boom arm to not open up to the limit.</p> <p>The Boom Arm Opening Brake Stroke can be set between 0 to 100 and the default value is 40.</p>	14E.040
15E.***	<p><b><u>Boom Arm Opening Brake Speed</u></b></p> <p>The smaller the number, the more pronounced the deceleration effect.</p> <p>If the deceleration speed is too small, it may cause the boom arm to not open up to limit, and the digital display will show: E*0.032.</p> <p>The Boom Arm Opening Brake Speed can be set between 0 to 100 and the default value is 20.</p>	15E.020
16E.***	<p><b><u>Boom Arm Closing Brake Stroke</u></b></p> <p>The larger the number, the greater the deceleration stroke.</p> <p>The deceleration stroke is too large, which may cause the boom arm to not close down to limit.</p> <p>The Boom Arm Closing Brake Stroke can be set between 0 to 100 and the default value is 40.</p>	16E.040

<p><b>17E.***</b></p>	<p><b><u>Boom Arm Closing Brake Speed</u></b></p> <p>The smaller the number, the more pronounced the deceleration effect.</p> <p>If the deceleration speed is too small, it may cause the boom arm to not close down to limit. If the boom doesn't close to limit, it will automatically bounce back to the open state (similar to rebounding when encountering resistance). If the radar ground-sensing signal is triggered at this time, the barrier gate will continuously open and close.</p> <p>The Boom Arm Closing Brake Speed can be set between 0 to 100 and the default value is 20.</p>	<p><b>17E.020</b></p>
<p><b>18E.***</b></p>	<p><b><u>Power-off Open Mode</u></b></p> <ul style="list-style-type: none"> <li>● <b>18E.000:</b> Disable</li> <li>● <b>18E.001:</b> Enable</li> </ul> <p>A dedicated power storage capacitor module needs to be installed, which triggers the opening of the gate when the power supply is below 21V.</p>	<p><b>18E.000</b></p>
<p><b>19E.***</b></p>	<p><b><u>Open/Close Limit LED State</u></b></p> <ul style="list-style-type: none"> <li>● <b>19E.000:</b> Open limit green light breathing, Close limit red light breathing</li> <li>● <b>19E.001:</b> Open limit green light always on, Close limit red light always on</li> <li>● <b>19E.002:</b> Open limit green light flashes, Close limit red light breathing</li> </ul>	<p><b>19E.000</b></p>
<p><b>20E.***</b></p>	<p><b><u>Open/Close LED State</u></b></p> <ul style="list-style-type: none"> <li>● <b>20E.000:</b> The red light flashes during the whole process of opening and closing the boom arm.</li> <li>● <b>20E.001:</b> The red light is always on during the whole process of opening and closing the boom arm.</li> </ul>	<p><b>20E.000</b></p>
<p><b>21E.***</b></p>	<p><b><u>RS485 Address</u></b></p> <p>The valid value is 0 to 250.</p> <p>The baud rate is 115200, used for reading status, sending parameters, and upgrading.</p>	<p><b>21E.000</b></p>

<b>22E.***</b>	<p><b><u>Ground Sense/Radar Delay Time Setting</u></b></p> <p>Set the delay time after triggering the radar ground sensor before lowering the boom arm, the larger the number set, the longer the delay time, the valid value is 0 to 251.</p>	<b>22E.000</b>
<b>23E.***</b>	<p><b><u>Self-test Mode</u></b></p> <ul style="list-style-type: none"> <li>● <b>23E.000:</b> Automatic self-test (After power on, the device automatically performs self-test.)</li> </ul> <p><b>Note:</b> It is necessary to install a radar ground sensor to prevent vehicle damage. During automatic self-checking, if a vehicle passes, the boom will automatically be raised for protection.</p> <ul style="list-style-type: none"> <li>● <b>23E.001:</b> Manual self-test (It requires manual opening and closing of the barrier gate for self check.)</li> </ul>	<b>23E.000</b>
<b>24E.***</b>	<p><b><u>Buzzer Mode</u></b></p> <ul style="list-style-type: none"> <li>● <b>24E.000:</b> Old mainboard</li> <li>● <b>24E.001:</b> New mainboard</li> </ul> <p>When the buzzer mode setting does not match the mainboard, the device will beep continuously under normal circumstances.</p> <p>When restoring the factory settings, this parameter will not be restored to the default value.</p>	<b>24E.001</b>
<b>25E.***</b>	<p><b><u>Motor Type</u></b></p> <ul style="list-style-type: none"> <li>● <b>25E.000:</b> Forward</li> <li>● <b>25E.001:</b> Reverse</li> </ul> <p>When the motor type is incorrect, the buzzer makes a sound alarm, and the digital display will show: E*0.001. Modifying this parameter will trigger a restart.</p>	<b>25E.000</b>

<p><b>26E.***</b></p>	<p><b><u>Remote Control Frequency</u></b></p> <ul style="list-style-type: none"> <li>● <b>26E.000:</b> 433MHz</li> <li>● <b>26E.001:</b> 430MHz</li> </ul> <p>When the remote control type changes, the remote control will be cleared.</p> <p>When restoring the factory settings, this parameter will not be restored to the default value.</p> <p>Modifying this parameter will trigger a restart.</p>	<p><b>26E.000</b></p>
<p><b>27E.***</b></p>	<p><b><u>Gate Opening and Ground Sensing Interface Switch</u></b></p> <ul style="list-style-type: none"> <li>● <b>27E.000:</b> Normal interface status</li> <li>● <b>27E.001:</b> Switch gate opening and ground sensing signal interfaces</li> </ul> <p>When this is set to "27E.001", the "IR / FIRE / DET / STOP / CLOSE / OPEN" interface is disabled, and the gate opening and ground sensing signal interfaces need to be connected to "IN2" and "IN1".</p> <p>When the old mainboard experiences signal interference and automatically opens or cannot close after opening, change this item to "27E.001".</p>	<p><b>27E.000</b></p>
<p><b>28E.***</b></p>	<p><b><u>Bluetooth/Wi-Fi Mode</u></b></p> <ul style="list-style-type: none"> <li>● <b>28E.000:</b> Bluetooth Mode (Enable)</li> <li>● <b>28E.001:</b> Bluetooth Mode (Disable)</li> <li>● <b>28E.002:</b> Wi-Fi Mode</li> </ul> <p>Switching Bluetooth mode and Wi-Fi mode will automatically restart the device.</p> <p>When restoring the factory settings, this parameter will not be restored to the default value.</p>	<p><b>28E.000</b></p>

<b>29E.***</b>	<p><b><u>Remote Control Button Function Switching</u></b></p> <ul style="list-style-type: none"> <li>• <b>29E.000:</b> Remote control center button (pause)</li> <li>• <b>29E.001:</b> Remote control center button (normally open)</li> </ul>	<b>29E.000</b>
----------------	--	----------------

## 5.5 Remote Control Settings

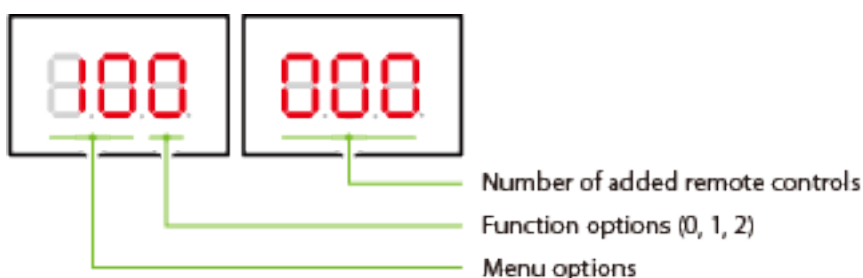

### 5.5.1 Remote Control Pairing

This operation is used to pair (add) the remote control and the steps are shown below.

1. Long press the [MENU/Save] button to enter the **Menu Options**, at this time the digital tube display

will show 000 000.

2. Then press [ADD/DEC] to set to "**Remote Control Pairing(10\*.\*\*\*)**" function, at this time the digital

tube display will show 000 888.

3. Then press [MODE/Toggle] to switch to "**Parameter Settings**" function, at this time the digital tube

display will show 000 888.

4. Press [ADD] key to set to 1 (increase the remote control), at this time the digital tube display will

show 001 888.

5. At this time, press any key on the remote control until you hear a drop from the mainboard, automatically back to the menu options, indicating that the pairing (add) success, the digital tube at

this time shows 000 000; finally long press the [MENU/Save] button to exit the menu.

## 5.5.2 Cleaning the Remote Control

This operation is used to clear all paired remotes, as follows.

1. Long press the [**MENU/Save**] button to enter the **Menu Options**. At this time, the digital tube display

shows .

2. Press [**ADD/DEC**] to set to "**Remote Control Pairing(15\*.\*\*\*)**" function. At this time, the digital tube

display shows .

3. Press [**MODE/Toggle**] to switch to "**Parameter Settings**" function. At this time, the digital tube

display shows .

4. Press [**ADD**] key to set to 2 (clear the remote control), at this time the digital tube display shows

.

5. Long press the [**MENU/Save**] button to save the settings and exit, and all the added remotes will be cleared at the same time.

## 6 Movement Description

### 6.1 Dimensions

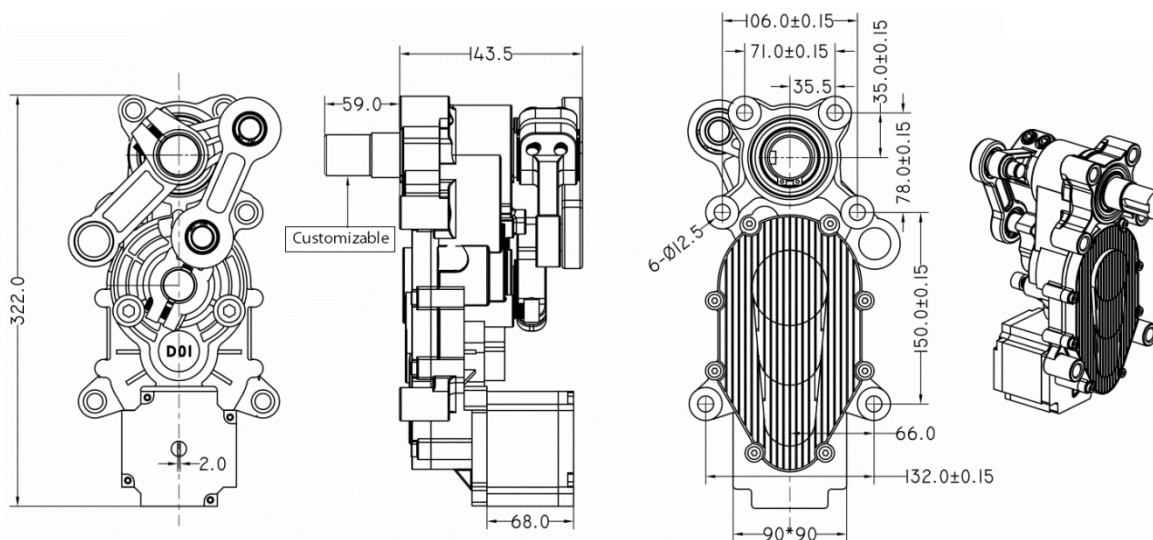

### 6.2 Horizontal and Vertical Angle Adjustment of Boom Arm (Mechanical Adjustment)

**Note:** The horizontal and vertical angles of the boom arm have been adjusted before leaving the factory. Please do not adjust them without the guidance of professionals to avoid mechanical damage.

#### 1. Adjust the horizontal position of the boom arm:

The connecting boom crank features an overlapping structure, aligning the two rotation points of the connecting boom arm with the output shaft of the reducer along a line. The boom arm is horizontally positioned in this configuration. If the boom arm is not level or is inclined, adjust by loosening the two rocker screws, align the boom arm to level, and then tighten the screws.

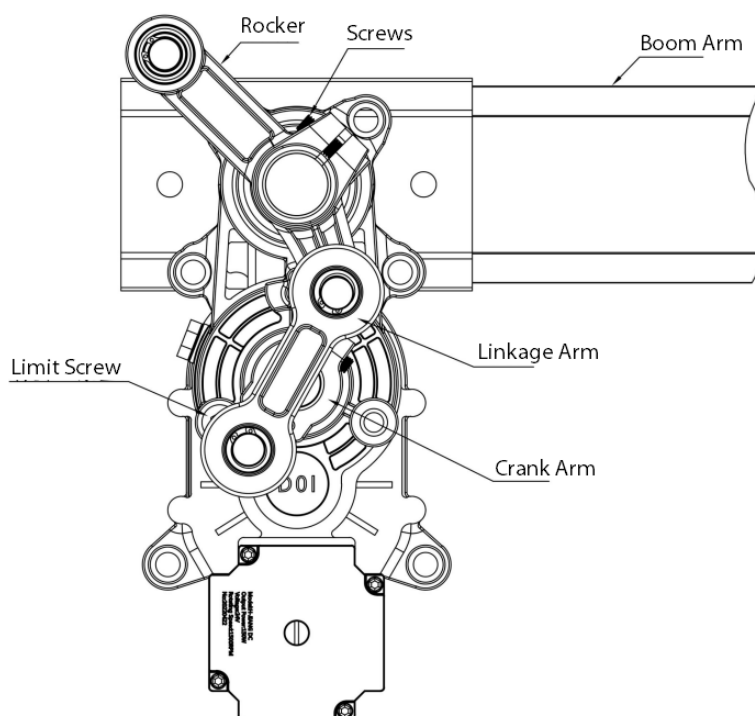

## 2. Adjust the vertical position of the boom arm (adjusted by mechanical structure)

The connecting boom arm crank is in an unfolded shape, aligning the two rotation points of the connecting boom arm and the reducer's output shaft in an unfolded 3-point line. This represents the boom arm's vertical position. If the boom arm is not vertically aligned and is inclined, adjust by loosening the two screws on the rocker arm, rotate the boom arm to the vertical position, and then tighten the screws.

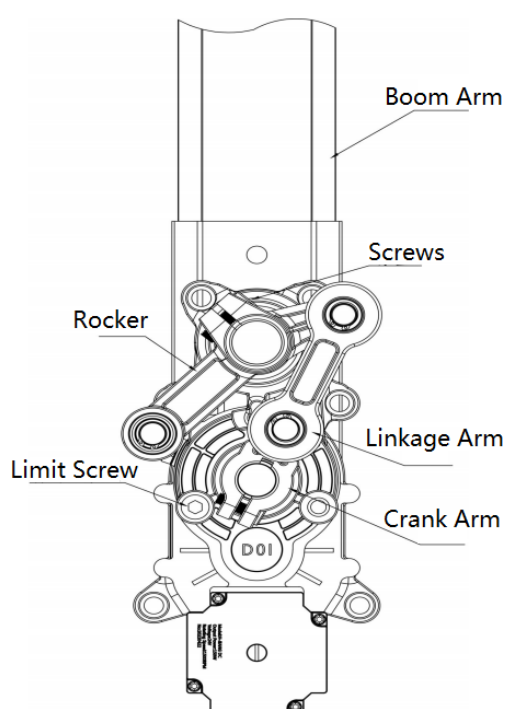

## 6.3 Direction Interchange of the Boom Arm

The operation steps are as follows:

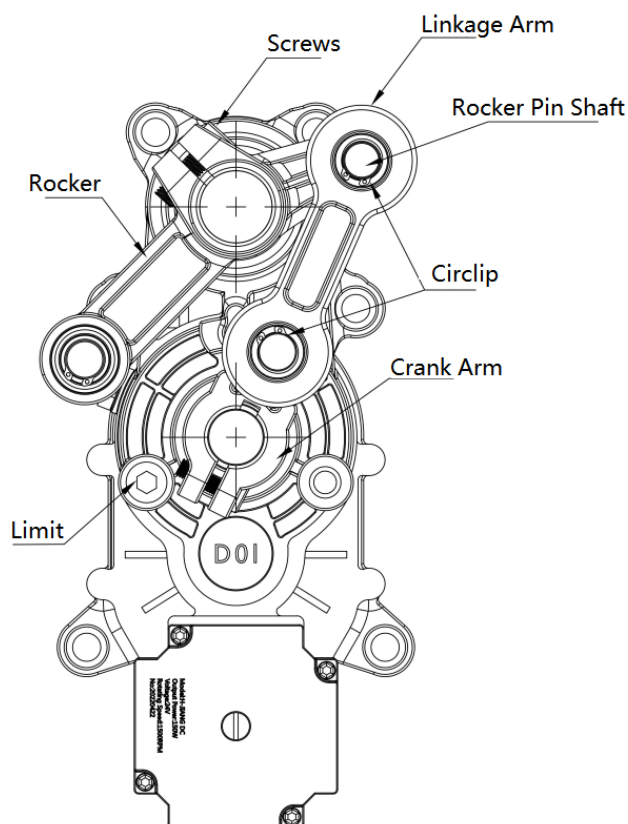

1. Before operation, please turn off the power. Remove the snap rings at both ends of the linkage arm with the external snap ring pliers and take out the linkage arm.
2. Loosen the two screws on the rocker, take out the rocker (the notch can be expanded with the help of the inclined iron to take out faster), take out the rocker pin shaft and change the direction.
3. Remove one screw on the limit, move it to the symmetrical position on the other side, and then lock it.
4. After installing the rocker pin shaft of the rocker, install the linkage arm and snap rings.
5. After adjusting the angle of the boom arm, lock the rocker screw.

**Note:** If it is difficult to remove the linkage arm, loosen the rocker and crank arm screw and remove them together, and then remove the linkage arm.

6. After the mechanical operation, you need to set the movement parameter 13E Core Component Position on the motherboard, such as changing from L to R, the value of this parameter should be set from 1 to 0, or set the direction of the movement on the app.

## 6.4 Spring Adjustment

If the boom arm shakes during the upward movement, adjust the spring to a looser setting. Conversely, if the boom arm shakes during the downward movement, adjust the spring to a tighter setting.

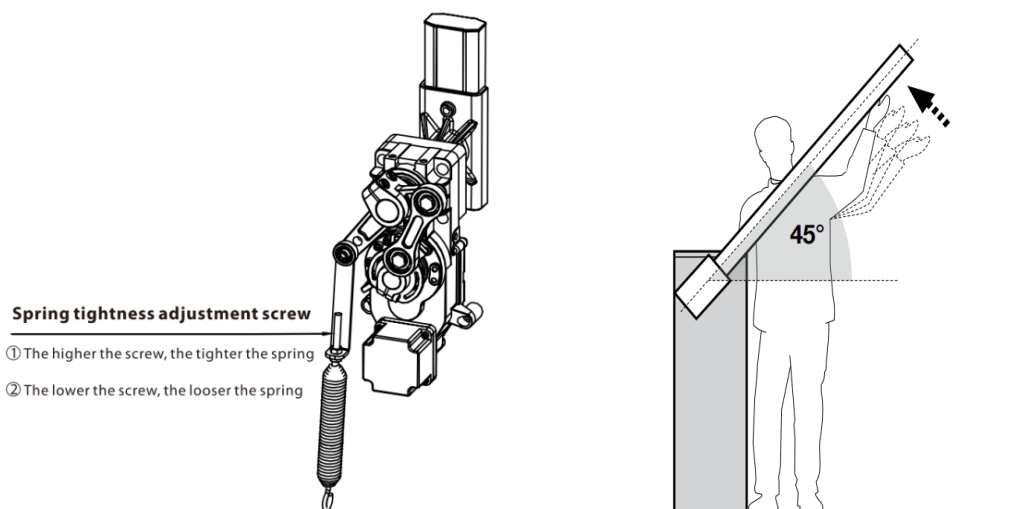

1. The best balance is when the barrier boom is at 45°.
2. The spring wire diameter is adapted to different boom lengths: 3m boom with  $\varnothing 4.5\text{mm}$ ; 4.5m boom with  $\varnothing 5.5\text{mm}$  and 6m boom with  $\varnothing 6.5\text{mm}$ . (If the boom is too short (less than 2m), do not install the spring).

## 7 Troubleshooting

SN	Trouble Description	Cause	Solution
1	The Power Supply has a 24V output, but the mainboard power indicator does not light up.	<ol style="list-style-type: none"> <li>24V output wiring might be reversed.</li> <li>The mainboard might work abnormally.</li> <li>Loose wiring.</li> </ol>	<ol style="list-style-type: none"> <li>Swap the DC output wiring.</li> <li>Replace the Mainboard.</li> <li>Tighten the wiring.</li> </ol>
2	The AC input is normal, but the power indicator is off.	<ol style="list-style-type: none"> <li>The power fuse might be blown.</li> <li>Abnormal power supply.</li> <li>Loose wiring.</li> </ol>	<ol style="list-style-type: none"> <li>Replace the fuse.</li> <li>Replace the power supply.</li> <li>Tighten the wiring.</li> </ol>
3	The power indicator is on, the landing boom indicator is normal, and the motor is not running.	<ol style="list-style-type: none"> <li>The motor wiring might be wrongly connected, or the wiring is loose.</li> <li>The internal encoder of the motor may work abnormally.</li> <li>The motor stroke limit exceeds the position.</li> </ol>	<ol style="list-style-type: none"> <li>Check the wiring according to the wiring diagram, and tighten the wiring if required.</li> <li>Reconnect the motor wire.</li> <li>Re-adjust the motor limit parameters.</li> </ol>
4	The remote-control buttons do not respond.	<ol style="list-style-type: none"> <li>The remote control is not using ZKTeco brand, or it is from another model.</li> <li>The remote control does not match.</li> <li>The remote control or the receiver is damaged.</li> <li>The remote-control battery is completely discharged.</li> </ol>	<ol style="list-style-type: none"> <li>Confirm to use ZKTeco brand and its applicable models for remote control.</li> <li>Rematch remote control.</li> <li>Replace the remote control or the receiver.</li> <li>Replace the remote-control battery.</li> </ol>
5	The boom cannot be closed normally after the machine is being powered on.	<ol style="list-style-type: none"> <li>The barrier gate is not installing the barrier boom, so the motor cannot be closed due to the strong pull of the spring.</li> <li>The length of the installed boom is too short, and the spring is too tight.</li> </ol>	<ol style="list-style-type: none"> <li>Install the boom normally or remove all the spring.</li> <li>Adjust the spring according to the length of the boom.</li> </ol>
6	The loop detector signal is not working.	<ol style="list-style-type: none"> <li>Wrong signal wiring.</li> <li>Install loop coil with few or too many turns.</li> <li>Detector damage.</li> </ol>	<ol style="list-style-type: none"> <li>Connect according to the wiring diagram.</li> <li>Calculate the circumference of the loop coil according to the width of the lane, and then confirm the number of turns installed.</li> <li>Replace new loop detector.</li> </ol>

SN	Trouble Description	Cause	Solution
7	The radar detector signal is not working.	<ol style="list-style-type: none"> <li>1. Wrong signal wiring.</li> <li>2. Distance and environment learning is not correct.</li> <li>3. Detector damage.</li> </ol>	<ol style="list-style-type: none"> <li>1. Connect according to the wiring diagram.</li> <li>2. Complete the installation test through the radar installation video or the user manual.</li> <li>3. Replace new radar detector.</li> </ol>
8	Abnormal shaking of the barrier boom occurred while opening and closing.	Spring too tight or too loose and the running speed too fast.	If the boom arm open shaking, it is necessary to loosen the spring and slow down the speed appropriately; if the boom arm close shaking, it is necessary to tighten the spring and slow down the speed appropriately.
9	The boom is not vertical and parallel after opening or closing.	<ol style="list-style-type: none"> <li>1. The spindle is not properly calibrated.</li> <li>2. Encoder travel limit error.</li> </ol>	<ol style="list-style-type: none"> <li>1. Loosen the screw on the spindle connecting arm and then adjust and calibrate the spindle direction.</li> <li>2. Adjust travel limit parameters again.</li> </ol>
10	Abnormal sound is heard when the motor is running.	<ol style="list-style-type: none"> <li>1. The motor rotor bearing is being damaged.</li> <li>2. Operating handle broken.</li> </ol>	<ol style="list-style-type: none"> <li>1. Replace new motor.</li> <li>2. Replace the new operating handle.</li> </ol>

## 8 Packing List

No.	Content	Quantity
1	Remote Controller	2 pcs
2	Key	2 pcs
3	Pull Blast Screw	4 pcs
4	Gate Lever Fixing Screw	2 pcs
5	Gate Lever Plate	1 pc

## 9 After-Sales Service

1. When the equipment works abnormally, it must be repaired by professional personnel, if it can not be solved, please contact the supplier.
2. This product has free warranty within one year.
3. Lifetime paid maintenance is provided.
4. The following conditions are not covered by the free warranty:
  - a) Users do not install and use the product according to the instructions, resulting in damage to the product.
  - b) The power supply is unstable, exceeding the specified range of the product or not in line with national standards for safe use of electricity and cause damage to the product.
  - c) Product damage caused by natural disasters and other irresistible factors.
  - d) Appearance damage caused by improper use of the user.
5. The company reserves the right to update the product.

ZKTeco Industrial Park, No. 32, Industrial Road,

Tangxia Town, Dongguan, China.

Phone : +86 769 - 82109991

Fax : +86 755 - 89602394

[www.zkteco.com](http://www.zkteco.com)

