

# JYS4控制系统使用说明

Instruction Manual for JingYanCNC-JYX4 Control System

适用C、M、F系列雕刻机 | ZH | EN



20260123A

使用控制系统前，请阅读附带说明书中的安全注意事项，当心触电。

Before using the control system, read the safety precautions in the supplied manual and beware of electric shock.

## I. Introduction

**⚠ WARNING** Before using the equipment, please read the instruction manual carefully to fully understand the relevant functions of the equipment. This ensures the correct use of the engraving machine and prevents accidents. Failure to comply with safety precautions and the instruction manual may result in electric shock, fire, or other dangers. Please keep the manual properly for future reference.

### 1.1 Safety Instructions

#### 1.1.1 Work Area Safety Guidelines

◆ Always keep the work area clean, orderly, and well-lit. Cluttered or dimly lit areas can easily cause accidents. All tools and materials should be stored in designated locations. Clean up waste and debris promptly to ensure a clean and unobstructed area. Never misuse cables; Do not use cables for lifting, dragging, or directly unplugging the controller.

◆ Strictly prohibit operating the equipment in flammable or explosive environments, including but not limited to places with flammable liquids, gases, or dust (such as wood chips, metal powder, organic particles, etc.). Equipment operation may generate electrical sparks or high temperatures, posing a combustion risk. The work area must be equipped with fire prevention facilities, and smoking or open flames are strictly prohibited.

◆ During operation, all unrelated personnel—especially children and bystanders—must maintain a safe distance from the equipment. The operator should concentrate and strictly avoid talking to others, using mobile phones, or engaging in any activity that may distract attention, to prevent loss of control and accidents.

◆ The work area must have good ventilation to promptly exhaust smoke and dust generated during processing. Simultaneously, ensure there is sufficient operating and evacuation space around the equipment, and avoid operating the equipment in cramped or enclosed environments.

#### 1.1.2 Equipment Electrical Safety Guidelines

◆ The engraving machine must use the original plug that exactly matches the power socket specifications. Modifying, removing, or adapting the original plug and wiring of the equipment in any form is strictly prohibited. All electrical connections must ensure reliable grounding. Using plugs or sockets without grounding function is forbidden. It is recommended to install a Ground Fault Circuit Interrupter (GFCI/RCD) in the power supply circuit to significantly reduce the risk of electric shock.

◆ Strictly prohibit operating or storing the equipment in damp, rainy, or liquid-prone environments. Water droplets or moisture entering the equipment may cause serious electric shock accidents. During operation, keep hands, feet, and the working environment dry. Avoid direct body contact with grounded objects (such as metal frames, water pipes, etc.) to prevent increased risk of electric shock.

◆ Do not pull, twist cables, or move the equipment or unplug by dragging the power cord. Power cords should be kept away from heat sources, oil contamination, sharp edges, and moving parts of the equipment to prevent insulation damage or wire breakage. Regularly inspect the cable condition. If aging, cracks, deformation, or overheating are found, stop use immediately and contact professionals for replacement.

◆ Non-professionals are not allowed to disassemble or modify the control box and motor parts. Any electrical repairs and component replacements must be performed by qualified electricians. If equipment leakage, abnormal heating, burning smell, arcing, or frequent circuit breaker tripping is detected, immediately cut off the power, contact after-sales service, and strictly prohibit operating with faults.

◆ It is recommended to install independent overcurrent and short-circuit protection devices in the equipment's power supply circuit. If the working environment has potential liquid splash risks, use waterproof sockets and cable protection sleeves additionally. When not in use for extended periods, disconnect all connections between the equipment and the power source.

#### 1.1.3 Personnel Safety Guidelines

◆ Please maintain a high level of vigilance, strictly adhere to operating procedures, and master basic usage knowledge before using the engraving machine.

- ◆ Always maintain a stable stance and body balance during operation, ensuring quick control of the equipment in case of emergencies.
- ◆ Wear appropriate work clothes, avoiding loose clothing and jewelry; Tie up long hair and keep it away from moving parts of the equipment to prevent entanglement.
- ◆ Adopt effective dust removal measures to reduce dust inhalation and explosion risks, and regularly check the equipment status to ensure all safety protection devices are intact and usable.
- ◆ Strictly prohibit untrained personnel from operating the engraving machine. Conduct daily safety drills and risk education to comprehensively improve accident prevention capabilities.

#### 1.1.4 Usage Safety Guidelines

- ◆ Do not force the installation of the engraving machine. During installation, use appropriate power tools. The specified tools not only improve installation efficiency but also ensure the safety and reliability of the installation process.
- ◆ Pay attention to regular maintenance of the engraving machine. Check for misalignment or binding of moving parts, broken components, and any other conditions that may affect engraving machine operation. If the equipment is damaged, the engraving machine must be repaired before use. Many accidents are caused by lack of equipment maintenance.
- ◆ It is recommended that a single machine be operated primarily by one person. If others need to assist or observe, they should maintain a safe distance to avoid accidental contact caused by multiple people operating simultaneously.
- ◆ Used, damaged tools that have been replaced should be placed in dedicated, puncture-resistant containers for centralized disposal. Random placement is strictly prohibited to prevent cuts.
- ◆ Before any inspection, maintenance, cleaning, or adjustment (including tool changes), the "Lockout-Tagout" procedure must be strictly implemented. This means disconnecting all energy sources (electrical) and attaching warning tags to prevent accidental activation by others.
- ◆ If the power switch cannot be turned on or off normally, immediately stop using the equipment. A machine that cannot be controlled by its switch poses a serious safety hazard and must be reported for repair and inspected by professionals promptly. Before making any adjustments, replacing accessories, or storing the equipment, always unplug the power plug. This preventive measure effectively avoids accidental startup of the equipment.
- ◆ Idle engraving machines should be placed in areas inaccessible to children. Operation by personnel who have not read and understood the manual is strictly prohibited. Operating an engraving machine by untrained users is highly likely to cause danger.
- ◆ Perform regular maintenance on the engraving machine, focusing on whether moving parts are misaligned, stuck, or have abnormalities such as breakage. Once damage is found, it must be repaired before continued use. Many accidents stem from lack of daily equipment maintenance.
- ◆ Keeping cutting tools sharp and clean is also very important. Well-maintained, sharp tools are less likely to break and cut more smoothly and safely.
- ◆ Before operation, fully assess the processing environment, material characteristics, and equipment capabilities, strictly following the instructions in the manual. Non-standard operations may cause serious accidents. Additionally, work in a well-lit and ventilated environment, ensuring the work area is tidy and free of clutter that may interfere with the operator's line of sight and movement path.

Please refer to the above safety instructions. When using engraving machines, accessories, cutting tools, and other equipment, carefully consider the working environment and the products to be processed.

**Failure to operate according to this manual may lead to dangers.**

## 1.2 Product introduction and features

### 1.2.1 Product Introduction

JYSE4 is a professional-grade multi-axis motion control core based on an embedded platform. system supports maximum 5-axis linkage control and integrates the ability of linear interpolation for 3-5 axes and any 2-axis circular interpolation. With a differential pulse frequency of up to 1MHz, it ensures high-precision machining and smooth surface treatment effects. The system hardware provides 24 input and 21 output interfaces, 0-10V analog voltage and PWM signals, which can flexibly adapt to variable frequency spindle, servo spindle, and multi-speed

control. It supports various tool libraries such as straight and disc, as well as multi-tool fixed tool setting functions, greatly enhancing the automation degree and efficiency of multi-process machining. The software level, the JYSE4 system employs advanced adaptive speed look-ahead control and small segment high-speed processing algorithms to intelligently plan machining paths. The system integrates practical features such as breakpoint memory/resumption, power-off protection, soft limit, and full-function G-code compatibility, and ensures the convenience of operation and safety through an intuitive UI interface and multi-level permission management.

JYSE4, with its stable and reliable industrial-grade performance, rich functional integration, and powerful expansion capabilities, has become an ideal control solution for application such as mold manufacturing, precision parts processing, and complex curved surface engraving.

### 1.2.2 Product features

- ◆ Maximum number of control axes: 3-5 linear interpolation, any 2-axis arc interpolation;
- ◆ Interpolation algorithm: S-shaped, arc-hard algorithm, arc-soft algorithm;
- ◆ Compensation method: direction gap compensation, radius compensation, length compensation;
- ◆ Collector open-circuit output, maximum current 500mA, can directly drive relays;
- ◆ Multi-segment preprocessing, adaptive speed look-ahead control of machining trajectory, fast machining speed, precision, good machining continuity;
- ◆ High-speed machining of small line segments, automatically select the most efficient algorithm among a variety of small line segment control algorithms;
- ◆ P direction using differential output, maximum interpolation pulse output frequency 1MHZ; Tool library type: multi-process, straight, disc;
- ◆ Tool setting type: fixed tool setting floating tool setting, multi-tool fixed tool setting;
- ◆ Network: supports file sharing and remote file online processing; Users achieve system and external file interaction through USB,
- ◆ completely operation; CNC software alarm: program error, operation error, overtravel error, servo driver alarm, etc.;
- ◆ With breakpoint memory, power-off protection function, nearby point processing and designated line processing function;
- ◆ has automatic return to origin, return to reference point, workpiece origin save and load function;
- ◆ Compatible with standard code, supports mainstream CAD/CAM software, such as UG, MasterCam, Powermill, etc.;
- ◆ Supports four levels of operation permissions (visitor operator, administrator, super administrator);
- ◆ Supports PWM output; Language: supports Chinese, English;

## II . Controller Specifications and Wiring

### 2.1 Structure of control box and handle

#### 2.1.1 Control box structure diagram

The structural schematic diagram of the control box is as follows:



#### 2.1.2 Schematic diagram of handle structure

The structural schematic diagram of the handle is as follows:



2.1.3 The size of the control box is shown in the following frame diagram.

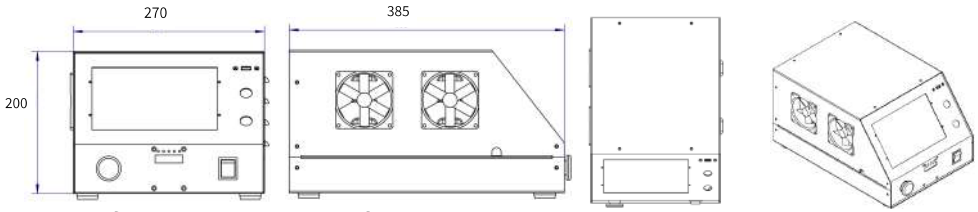

2.2 Specifications and wiring of internal appliances

2.2.1 Specifications of internal appliances

The specification parameters of the internal electrical appliances of the control box are as follows:

Name of electrical appliance	Specifications	Picture
Control box	Voltage: AC 220V Power: 1.5KW (1.5KW ball rod machine) 1.8KW (1.5KW four-station machine) 2.5KW (2.2KW model)	
Frequency converter	Input voltage: AC 220V Output voltage: 0~220V Output current: 7.0A Rated power: 1.5/2.2KW Phase number: 3PH Frequency: 50Hz / 60	
Motion control card	Input voltage: 24V output: signal	
Switch power supply	Input: AC220V 3.5A AC110V 5.5A (custom) Output: 24V 10A Output power: 250W Frequency: 50Hz / 60Hz	

⚠\*Please use a national standard AC power outlet! (It is recommended to use a grounded protection outlet to ensure safety; avoid sharing the same circuit with other highpower electrical appliances to prevent overloading.)

2.2.2 Airline connection wiring

The aviation plug is used to achieve the electrical connection of the engraving machine, and different functional interfaces need to correspond to different specifications of the aviation. The X, Y, Z, and A axes are connected to the corresponding axis drive motor respectively to control the movement function in each axial direction. The limit switch is connected to limit device of the X, Y, Z axis of the machine tool (the system uses the XYZ axis origin switch as the limit signal source, configured as 3 hard limits 6 soft limits), which is used to achieve the travel protection function. The main spindle motor interface connects the main spindle drive circuit, which is used to control the of the main spindle. The water cooling system interface connects and controls the operation state of the main spindle water cooling unit. The tool setting interface can be connected to the tool instrument to realize the automatic tool setting operation. The output interface is a reserved interface, and customers can connect other signals according to their own situation. The expansion interface is a reserved interface, which can be connected to a four-core tool setting device to realize the automatic tool setting operation.

\*Wiring note: Connect the cable of the aviation plug of the engraving machine body to the corresponding port on the control box according to the corresponding identification. The A-axis and the centering device are both optional products. If not purchased, there is no need to connect the wiring). Then connect the power cord to the 20V input socket of the control box.



The wiring of the air line is shown in the following table:

XYZ Axis (7-pin)	Limit Switch (8-pin)	Spindle Motor (5-pin)	Water Cooling (4-pin)	External Switch external switch (4-pin)	Tool Setter (2-lines)	Output (2-lines)
24V+	X-	U	12V+	start	24V+	24V+
PUL+	X+	V	GND	Reset	24-	24-
PUL-	Y-	Blocking net	24V+	/	/	/
DIR+	Y+	W	GND	COM	/	/
DIR+	Z+	PE	/	/	/	/
GND	Z-	/	/	/	/	/
ALM	24V+	/	/	/	/	/
/	GND	/	/	/	/	/

### 2.2.3 System wiring

The schematic diagram of the system connection is as follows:

The interface schematic diagram of the motion control card is as follows:

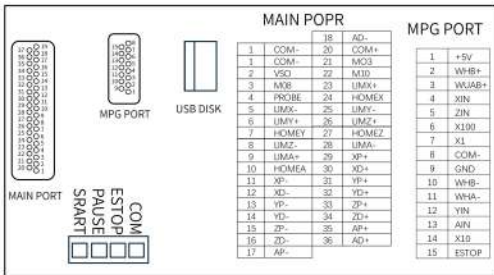

COM and COM- are the input and output power input terminals, 24V and GND are the system power input terminals, the two inside are completely isolated, and the two must be powered by separate switch mode power supplies!

Note\*:

1. This wiring diagram has a deviation from the actual pin position layout, please wire according to the actual pin numbering!
2. The input is low-active, default NPN type proximity switch;
3. The system pulse direction command output is a differential output, it is forbidden to short the positive or pole of the differential output as a single-ended use!
4. The common position of the main shaft analog output and the PWM output is ACM;
5. main shaft analog output ground ACM must not be short-circuited with DCM (COM-), the two are completely isolated internally;

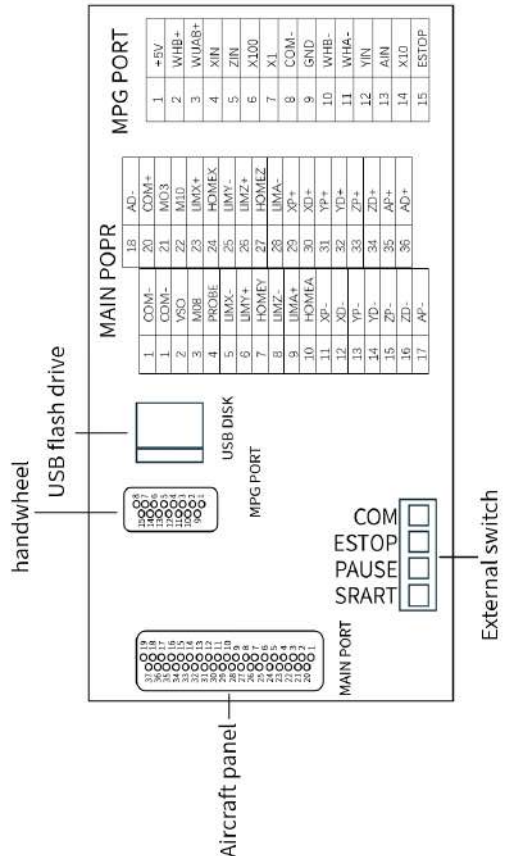

### III. Controller Function Description

The software interface contains a total of 4 pages, including the main control page, file page, configuration page, and diagnosis page. The specific content is as:

#### 3.1 Main control interface



As can be seen from the above figure, the main control page is divided into four major modules: the status bar, the coordinate display bar, the basic parameter, and the prompt bar. In total, it is divided into 19 areas. The 19 areas are described in detail below:

#### 1. X coordinate

This column shows the current value of the X workpiece coordinate, with a display range of -99999.999~ 9999.999, and the minimum step value is 0.001.

#### 2. Y coordinate

This column shows the current Y workpiece coordinate value, the display range is -99999.999~99999999, and the minimum step value is 0.001.

#### 3. Z coordinate

This column displays the current Z workpiece coordinate value, with a display range of -99999.999~ 9999.999, and the minimum step value is 0.001.

#### 4. A coordinate

This column shows the current A workpiece coordinate value, the display range is -99999.999~99999999, and the minimum step value is 0.001.

#### 5. Current running line

This column displays the current running line number and instruction when executing the G instruction file, and displays blank when the running status is idle.

#### 6. Page indication

Page indication, indicating the current page, this controller has a total of 4 pages, including the main control page, file page, configuration page and diagnostic page .

#### 7. Operation prompt

There are only 3 states of this prompt, mainly to quickly prompt the status bar and display the second function of several key buttons.

The prompt message in normal state is: normal mode.

The prompt message for the second function startup state is: X-: Home; Y-: Clear; Z-: Find; X : Divid X; Y : Dividing Y; Z : Touching. The prompt message indicates that in this state, clicking the X-key enters the function of returning to workpiece zero point; clicking Y- enters the current coordinate clearing function; clicking Z- enters the function of finding the mechanical zero point; clicking X performs X-axis division clicking Y performs Y-axis division; clicking Z performs the touching operation.

In the state of editing numbers in this column, the prompt information for the key is: X : Move the cursor left; X-: Move the cursor right; Y : Increase the value; Y-: Decrease the value; Z-: Confirm; Z : Cancel.

#### 8. Current coordinate system

Feed rate can be modified. This column value can be modified by the A-key.

You can switch to this column via the [Coordinate System] key and modify the current coordinate system via A /A-. The modification range is G54-G59. When switching to this column, the G54 font will be bold. In the state of editing numbers in this column, the prompt information of key is: X : Move the cursor left X-: Move the cursor right Y : Increase the value Y-: Decrease the value Z-: Confirm Z Cancel.

#### 9. Status of M3/M5, M8/M9, and M10/M11

M3/M5: Start/stop spindle; M8/M9: Start/stop coolant; M10/M11: Startstop lubricant.

#### 10 Spindle speed

S stands for the spindle speed. This column can be switched to by pressing the [Parameter switch] key, and the S letter will be bold switched to it. This column can be modified by the A-key. The 0 position on the left shows the actual spindle speed, and the 12000 on the right shows the default spindle speed, which can be modified.

#### 11. Feed rate

F stands for the speed of the feed. This column can be switched to by pressing the [PARAMETER SWITCH] key, and the F letter will be when switched to this column. The position of the left value displays the actual real-time feed rate, and the position of the right value displays the default feed rate, which is default.

#### 12. Manual adjustment

This column can be switched to by the [PARALLEL SWITCH] key. The hand control adjustment letters are bold when this column is switched to. press the "MODE" key to make sure the controller is in the manual or continuous, inching or handwheel state.

In continuous state, A and A- can be adjusted by 10% increase or decrease;

In the state of inching, A and A- can be increased or decreased by 0.01mm, 0.1mm, 1mm or

10mm as the unit of increase or decrease these four parameters are default values, and users can customize and change them according to their own needs;

In the state of handwheel, the handwheel can be used to operate the machine.

### 13. Main spindle adjustment

You can switch to this bar by pressing the [parameter switching] key, when switching to this bar, the main shaft adjustment font will be bold, at time, press the A key to increase the main shaft adjustment value, press the A- key to decrease the main shaft adjustment value, each step increases or decreases by 10 percent.

### 14. Feed adjustment

You can switch to this column by pressing the [PARA SWITCH] key, and when you switch to this column, the feed adjustment text will be bold and at this time, press the A key to increase

Feed adjustment value, press the A-key to reduce the feed adjustment value, each step increases or decreases by 10%.

### 15. Working hours

This column shows the machining time, starting from the time the G code starts running, until the machining end time stops, and the time will also pause the pause.

### 16. Machining file

This column displays the processing files, normally only the file name is displayed, and in the case of breakpoint continuation, the file directory will also be displayed.

### 17. Operation status

This column shows the device operation status, and the displayable status and meaning are as follows:

Device busy: in the state of processing, manual operation of a single axis, or any other arbitrary axis in operation;

Reset: The flashing reset indicates that it has entered the reset state, during which no other key works;

Idle: Ready state, in the reset state, press the reset key to enter the idle state, at this time you can perform automatic machining, or other parameters, etc.

### 18. Feed state

This column shows the device feed state, and the displayable states and their meanings are as follows:

Automatic: Processing executing G code file status, display automatic;

Continuous: To indicate continuous movement, press and hold the - or of XYZA, which allows each axis to move continuously;

Inch jog: Indicates a point jog. When this is selected, tapping the - or on the XYZA will move each axis one unit distance This unit distance can be modified in the Handwheel Adjust Parameters. Even if you hold down these keys, each axis can only move one unit distance. This function can be used for positioning.

Handwheel: indicates entry into hand pulse mode, where the hand pulse is effective and can be used to operate the position of each axis;

Second function: Press the key to enter the second function state, and the second function is displayed on the status bar at this time .

### 19. Mechanical

The mechanical coordinates can be seen in real time through this column.

## 3.2 File management page



Press the [Page] key once to enter the file management page.

#### 1. Switch directory bar

".." indicates entering the parent folder directory;

#### 2. Current folder subfolder list

What is shown in Box 2 is the list of all subfolder directory in the current folder;

#### 3. Current folder file list

The list of all files in the current folder is shown in Box 3;

#### 4. File modification time bar

Box 4 shows the modification time of each file or folder, which can be used to judge the status of the file or folder.

#### 5. Keyboard operation bar

Since this version of the controller adds keyboard operation, on the file page, users can operate the file according to the above prompt with the corresponding key of the keyboard .

Note: Here the file can be scrolled up and down, not only with the panel and keyboard but also with the handwheel.

## 3.3 Configuration interface



After pressing the [PAGE] key once again, the machine configuration page will be displayed. Except for the panel and keyboard, the parameters can be quickly found using the handwheel. The configuration parameters are generally set by the manufacturer at the factory and should not be modified without permission. As shown in the figure, the configuration is divided into a total of 4 columns.

**1. Parameter numbering**

Each parameter has a specific label, and the parameter can be modified by the configuration file method, so you can specify it by the parameter label.

**2. Parameter definition**

The actual definition of the parameter is listed in the parameter definition column, note that all parameters are grouped by function, and the group title format is [Group] the [Motor Configuration].

**3. Parameter value**

The column of parameter value lists the specific value of each parameter, which has integer, floating point, BOOL switch and other types of data, as shown in 33, the value of parameter No. 50.000 is floating point data.

**4. Parameter unit**

Parameter units list the units of each parameter.

**3.4 Diagnostic interface**

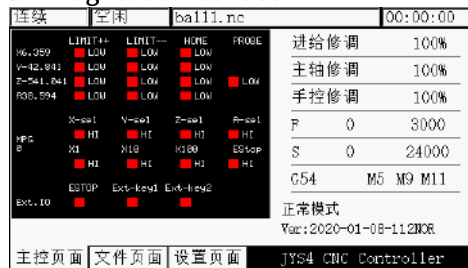

After pressing the [Page] key once more, enter the diagnostic interface.

**1、Limit++**

Display the working level of the X, Y, Z, A-axis positive limit, LOW for low level, HI for high level.

**2、Limit--**

Display the working level of the negative limit of the X, Y, Z, A-axis, LOW for low level, HI for high level.

**3、Home**

Display the working level of the machine tool origin of the X, Y, Z, A axis, LOW for low level, HI for high level.

**4、Probe**

Display the working level of the touch probe of the tool setting device, LOW for low level, HI for high level.

**5、X、Y、Z、A-Sel**

Display the working level of the X, Y, Z, A-axis handwheel spindle switch, LOW for low level, HI for high level.

**6、X1、X10、X100**

Display the working level of the handwheel rate switch, LOW for low level, HI for high level.

**7、MPG-Estop**

Display the working level state of the emergency stop handwheel, LOW for low level, HI for high level.

**8、Estop**

Display the working level state of the external emergency stop, LOW for low level, HI for high level.



**9、Extkey1/2**







Display the working level state of extended keys 1 and 2, LOW for low level, HI for high level.







**3.5 Panel key functions**

The figure shows the key layout diagram of JYS4, JYCS4 has a total of 17 keys. The specific key definition is shown in following table:



Key icon	Key function	Functional description
	Start run	①、 After loading the G code file correctly, press this key to start the automatic machining operation; ②、 Or in the paused state, press this to resume machining operation.
	Pause run	Processing, press this key to pause.
	Emergency stop reset	①、 In the reset state ("Reset" flashing), press this key to enter the ready state; ②、 In the machining state, press this key to stop the machining in an emergency.

Key icon	Key function	Functional description
	<p>Test cut</p>	<p>Switch the machining mode to manual wheel test cutting or automatic machining.</p>
	<p>Manual spindle on/off</p>	<p>①、 In the ready state (idle), press this key to manually turn off/on the spindle; ②、 This function cannot be operated the reset state (reset) and machining state (busy).</p>
	<p>1: X-axis move left; 2: Cursor move left; 3: Return to workpiece zero; 4: All-axis return zero.</p>	<p>①. In the ready state (idle), when the switch mode is "continuous", this key moves the X-axis to the left in with pressing; ②. When switched to "inching", it is a leftward incremental move; ③. When entering the machining line edit or default F/ value modification state, this key has the function of moving the cursor to the left; ④. In the case of starting the second function, this key is the function of enabling return to workpiece zero function; in the search for zero/clear zero/return to zero these 3 functions, when it is necessary to start the single-axis operation, key is the full-axis return to zero function;</p>
	<p>1: X-axis right shift; 2: Cursor right shift 3: X in the middle 4: X-axis</p>	<p>①、 In the ready state (idle), with the switch mode set to "continuous", this key moves the X-axis to the right pressed; ②、 When switched to "inching", it performs a rightward incremental move; ③、 When entering the machining line edit or default F/S modification state, this key functions as a cursor right move; ④、 In the start of the second function, this key is the X-axis centering function; in the for zero/clear zero/return to zero these 3 functions, when single-axis operation is required to be started, this key is the X-axis selection function;</p>
	<p>1: Y-axis shift forward; 2: Parameter value increase 3: Y in the middle; 4: Y-axis</p>	<p>①、 In the ready state (idle), with the switch mode set to "continuous", this key is pressed to move the Y-axis in conjunction; ② When switched to "inching", it is a forward incremental move; when entering the machining line edit or default F/S value modification state, key is to increase the current position function; ③ When the second function is started, this key is the Y-axis centering function; ④ In the search for zeroclear zero/return to zero these 3 functions, when single-axis operation needs to be started, this key is the Y-axis selection function;</p>
	<p>1: Y-axis moved backward; 2: Parameter value decreased 3: Clear workpiece zero 4: Full-axis clear</p>	<p>①、 In the ready state (idle), with the switch mode set to "continuous", this key moves the Y-axis backward when pressed ②、 When switched to "inching", it performs a backward incremental move; when entering the machining line edit or default F/S value modification state, this key enables the current position function; ③、 In the case of starting the second function, this key enables the coordinate reset function; ④、 Under the three functions of seek zeroclear zero/return to zero, when single-axis operation needs to be started, this key performs an all-axis reset function;</p>

	<p>1: Z-axis lifting; 2: Z-axis selection 3: Cancel 4: Touching the knife</p>	<p>①、 In the ready state (idle), with the switch mode set to "continuous", this key is pressed to raise the Z-axis ②、 When switched to "inching", it is a momentary raise; ③、 Under the three functions of seek zero/clear zero/return to zero, key is used to select the Z-axis function when single-axis operation is required; ④、 In the case of entering the start line, editing the F/S default, or the file management page, this key is the cancel key; ⑤、 In the case of starting the second function, this key is the touch-off function;</p>
	<p>1: Z-axis approach; 2: Search for machine origin 3: Confirm/select 4: Full-axis search for</p>	<p>①、 In the ready state (idle), with the switch mode set to "continuous", this key performs a downcut with the Z-linked; ②、 When switched to "inching", it is a point-to-point downcut; ③、 When the second function is started, this key used to activate the function of seeking the machine coordinate origin; ④、 When entering the start line, F/S default value edit, or file management page, this key is confirmation or selection key; ⑤、 Under the three functions of seeking zero/clearing zero/returning to zero, when it is necessary to start single-axis operation, key is used for the function of seeking zero on all axes;</p>
	<p>1: A-axis inversion; 2: Parameter reduction; 3: F/S default value modification;</p>	<p>①、 In the ready state (idle), when the mode is switched to "continuous", pressing this key reverses the A axis; , switching to "inching" is a reverse jog; ③、 in the feed adjustment / spindle adjustment / hand control adjustment parameter modification state, pressing this key decreases the parameter value; ④、 in the state of switching to F or S, pressing this key enters the default value editing state;</p>
	<p>1: Feed/spindle/hand control adjustment/F/S/G switch; 2: File copy</p>	<p>①、 Under the machining page, in the ready state (idle), pressing this key can switch between 8 states including feed adjustment/sp adjustment/manual adjustment/F/S/G/soft limit and ready state; ②、 Under the machining state (busy), only feed adjustment/spindle and machining state can be switched among 3 states.</p>
	<p>1: Sports mode switch 2: File deletion</p>	<p>①、 Under the machining page, in the ready state (idle), pressing this key can switch the manual mode of each axis, there are total of 3 manual modes, namely "inching", "continuous" and "handwheel mode"; ②、 Under the file management page, pressing this key is function of deleting the currently selected file;</p>
	<p>1: A-axis positive rotation; 2: A-axis selection; 3:Parameter increase; 4: F/S default value selection/ancellation</p>	<p>①、 In the ready state (idle), when the mode is switched to "continuous", this key is pressed to drive the A axis; ②、 When switched to "inching", it is used for forward jogging; ③、 Under the three functions of seek zero/clear zero/return to zero this key is used to select the A axis function when single-axis operation needs to be started; ④、 In the state of feed adjustment/spindle adjustment/hand control parameter modification, this key is pressed to increase the current parameter value; ⑤、 When switched to F or S state, this key selects the default value as the effective value selects the G code set value as the effective value;</p>
	<p>1: Second function start; 2: File paste;</p>	<p>①、 Under the processing page, in the ready state (idle), pressing this key can switch to the second function state; ②、 In second function state, the corresponding key can be pressed to start the four functions of seek zero/clear zero/return to zero/set the tool, etc.; ③、 ing it again will exit the second function, or some operations will automatically exit the second function; ④、 Under the file management page, pressing this key will paste the file that been copied to the current folder;</p>

## IV. Equipment Operation Process

### 4.1 Equipment startup and commissioning

① Check all the wiring and external devices of the machine before starting it. After checking, turn the emergency stop knob clockwise and press the power button to power the machine. Wait for the system interface to load.

② After loading the CNC system, the system will keep flashing "Reset". Click the [Reset] key, and then a dialog box will pop asking "Do you want to return to the machine origin?". Click the [Z-] key in the operating system to return to the machine origin.

③ Control the movement of the corresponding axis by means of the [X], [X-], [Y], [Y-], [Z], [Z-], [A] and [A-] on the operating system or by means of the handwheel and check whether the movement function of corresponding axis is normal.

④ Move each axis to the maximum and minimum values of the machine's travel to detect whether the machine's travel limit protection function is normal.

⑤ Press the main shaft switch in the operating system to control the start and stop of the main shaft, and check whether the main shaft function is normal. **(Pay attention to whether the tool is clamped on the main shaft. If there is a tool, make sure the tool is clamped firmly to prevent the tool from flying out and injury.)**

⑥ Check whether the main shaft water cooling fan and water cooling pump start normally after power on.

### 4.2 Set the workpiece zero point

After the tool is clamped to the spindle and the workpiece is clamped, the machine can be controlled to move in positive and negative directions with XYZ positive and negative movement keys on the system. The coordinates of the three axes can be set to zero after the machine spindle is moved to the programming setting machining coordinate. For easy setting of the workpiece origin, the machining origin is generally set at the lower left corner of the material or at the center of the material during programming.

Below is an example of the workpiece origin in the lower left corner of the material: First, move the spindle to a safe height, then quickly move each axis (handwheel  $\times 100$  or continuous mode of the system) to the vicinity of the workpiece origin set by the program (within 2-mm from the workpiece origin), and then switch to the handwheel mode, adjust the handwheel ratio to  $\times 10$ , and slowly move each axis to approach the work origin. When about to touch the workpiece origin, adjust the handwheel ratio to  $\times 1$  state, move slowly,

and when the tool slightly touches the workpiece origin or there a small amount of material cutting when turning the screw cap, you can perform the "clear workpiece zero" operation, click the [Second Function] key, and click the [-] key twice to perform full-axis zeroing. By this point, the workpiece origin is determined.

If the machining origin is set at the material center, it is necessary to perform a centering operation to determine the position of the machining origin, as in 6.4 and 6.5.

### 4.3 Load the program

After finding the workpiece origin, copy the required machining program to a USB flash drive, plug the USB flash drive into the system, save the code that to be machined to the local disk of the system, and then load it into the control system. For specific operations, please refer to 5.2.

### 4.4 Start mach

After the machining program is loaded, press the [Start] button, and the machine will start to run the program.

## V. Common function operation methods

### 5.1. File management



#### ◆ Path description

Click the [Page] key under the main page to enter the file management page, as shown in the figure. At this time, all folders and under the root directory of the USB flash drive are displayed, and the size column corresponding to the folder name displays [DIR], and the size column corresponding to the file displays the size of the file. The blue bar indicates the current selected target position. Press the [Y] key to move up; press the [Y-] key to move down; the [Z] key to exit the file management page; press the [Z-] key to confirm, if the current target item is ".", exit the directory and enter the upper directory, if the current target item is a folder, enter the target item folder, if the current target item is the target G code file, select the file.

(1) Copy file

Select the target file "2mmnew.tap" on the file management page and press the [Parameter Switch] key to copy this file ;

Name	Size	Time
..	[DIR]	1970/01/09 08:18
install	[DIR]	1970/01/09 08:18
目标文件夹	[DIR]	1970/01/09 08:18
2mmnew.tap	1525365	2018/07/16 17:32
setting	170000	1980/01/01 00:00
BWF1.tnp	261174	1970/01/01 00:01
BWF0.tnp	261174	1970/01/01 00:00
BWF2.tnp	261174	1970/01/01 00:01
Bear Shape 3d v2.crv3d	5411840	2016/01/18 16:35
3D Roughing Bear v2.tap	553829	2016/01/18 16:34
Profile 1.tnp	74952	2016/02/09 22:20
V-Curve 1.tnp	135642	2016/02/09 22:20

(2) Paste file

Then switch to the target folder to paste into. When you first come in, there is no 2mmnew.tap file under the target folder. Press [Second Function] key to paste the 2mmnew.tap file into this directory;

Name	Size	Time
2mmnew.tap	1525365	1980/01/01 00:00
BWF0.tnp	261174	1980/01/01 00:00
BWF1.tnp	261174	1980/01/01 00:00
BWF2.tnp	261174	1980/01/01 00:00
BWF3.tnp	261174	1980/01/01 00:00

(3) Delete file

When the target file 2mmnew.tap is selected, press the [Mode Switch] key to delete this file.

5.2. Load G code

Press [Page] under the main page to enter the file management page, After inserting the USB flash drive use the [Y] and [Y-] keys to select the G-code file to be loaded, copy the target file to the local disk first, and then switch the local disk to find the target file. After pressing the [Z-] key to load this file, the system will automatically return to the machining page.

5.3 Start automatic run

X	-38.542	-38.542	mm	进给修调	100%
Y	-50.025	-50.025	mm	主轴修调	100%
Z	-1.999	-1.999	mm	手控修调	0.01
A	0.000	0.000		F	56 3000
10: X-38.385				S	13999 14000
Ver: 2019-04-25-107NOR				G54	M3 M9 M11
正常模式					
主控页面   文件页面   配置页面   JYS4 CNC Controller					

After loading the machining file, At this time, need to set the workpiece origin point according to actual needs. For example, if the G-code file uses the center of the workpiece as the origin point, you can the tool tip to the center of the workpiece, then press the [Second Function] key and press the [Y-] key twice to set the current full-axis coordinate zero. At this time, the center position of the workpiece is the origin point of the workpiece. After setting, press the [Start] key to start automatic machining to the G file. During the automatic machining process, only the [Start], [Pause], and [Reset] key panel keys are effective, and the [Management] key can only set the feed rate adjustment and spindle adjustment values.

5.4 Run with breakpoint

Press the [Second Function] key to enter the second function mode, in the second function mode, press the [Pause] key again to enter thepoint run, at this time the equipment will run from the last recorded breakpoint. Note: This system will automatically record the breakpoint when pressing the [Pause] key and off.

5.5 Start running from specified line

Press the [Second Function] key to enter the second function mode, in the second function mode, press the [Start] key to enter the specified line, at this time, the current line position will pop up a text box to prompt the modification of the starting processing line. As shown in the figure below, the black 0 the position of the cursor, at this time, the cursor can be moved left and right by [X-] and [X ], and the value of the position where cursor is located can be changed by [Y ] and [Y-], as shown in the figure, the starting line is modified to 1718 .

X	4.915	4.915	mm	进给修调	100%
Y	-45.225	-45.225	mm	主轴修调	100%
Z	-1.207	-1.207	mm	手控修调	0.01
A	0.000	0.000		F	0 99999
1718: X4.915Z-1.207				S	15998 16000
Ver: 2019-04-25-107NOR				G54	M3 M9 M11
正常模式					
主控页面   文件页面   配置页面   JYS4 CNC Controller					

5.6. Pause during running

During operation, press the [Pause] key, the program pauses, and the status bar displays "Idle", the Z-axis safety height set to 5mm by default, and the Z-axis automatically lifts the tool to a height of 5mm. The spindle is not turned off.

### 5.7. Stop during running

Press the [Reset] key to perform an emergency stop of the program, at which time the "Reset" message is displayed and flashing on the run status bar and the spindle is turned off. Emergency stop during operation.

### 5.8. Start/stop spindle

The main spindle can only be manually started or stopped when it is displayed as "idle" on the running status bar; Press the [Main Axis] key to turn off the main axis, and in the state of the main axis being turned off, press the [Main Ax] key to turn on the main axis. When the "Reset" and "Busy" are displayed on the operation status bar, this operation cannot be performed

### 5.9. Manual adjustment

When searching for the workpiece coordinate point 0, or when it is necessary to move the spindle to a certain position, manual adjustment is required. adjustment can be divided into three types of motion: inching (manual tapping), continuous (manual continuous), and hand pulse. These three modes can be switched by pressing the [Mode Switch] button.

#### 5.9.1 Manual incremental movement X axis

When searching for work, press [Mode Switch] to display the feed state as "inching", then enter the inching mode, as shown in the following figure, at this time, the hand control adjustment parameter displays the step value of point movement, the current value is 0.01, indicating that one point movement moves 0.01mm, press the X-axis left 0.01mm, press the X-axis right 0.01mm. Y/Z/A and other axes are the same.



#### 5.9.2 Manual continuous operation of the X-axis

By pressing [MODE SWITCH] to make the feed state display as "CONTINUOUS", it enters the linkage mode, at this, the handwheel adjustment parameter displays the manual gear, the current value is 100%, indicating that the linkage speed is the default manual speed, at this time press [X-] X-axis left move, press [X ] X-axis right move. In "Continuous Mode", pressing [X-] or [X] for no

more than 1s, the system will automatically identify as an inch, and the X-axis will only move the preset value of the inch step. If exceeds 1s, it will be recognized as a continuous mode, and the X-axis will move continuously. Y/Z/A and other axes are the same.



#### 5.9.3 Use of the hand pulse

Press [MODE SWITCH] to display the feed state as "handwheel" and enter the handwheel mode. At this time, switch the channel selection the handwheel to X, select the appropriate position on the gear switch, and then turn the handwheel, the X-axis will follow the hand pulse movement, and other axes follow suit.



### 5.10. adjustment

The system supports quick modification of parameters including feed adjustment, spindle adjustment, SRJ adjustment, F value modification, S value modification, and coordinate system selection Pressing the [Mode Switch] key can cycle through the adjustment of these 6 parameters.

#### 5.10.1 Feed adjustment

Under the condition that the operation status bar displays "idle," press the [Parameter Switch] once to enter the feed adjustment regulation state, at which the feed adjustment font becomes bold, as shown in the figure. At this time, press [A ] to increase the feed adjustment value, press [A-] to decrease feed adjustment value, and the step value is 10%.

Current feed rate F# = Set feed rate F\* feed adjustment.

连续	空闲	2mmnew.tap	00:01:06
X	-9.441 mm	<b>-9.441</b> mm	进给修调 120%
Y	-42.225 mm	<b>-42.225</b> mm	主轴修调 100%
Z	4.749 mm	<b>4.749</b> mm	手控修调 100%
A	0.000 mm	<b>0.000</b> mm	F 0 3000
3137: X-11.278Z-0.196		S 13999 5777	
主控页面		文件页面 配置页面	
JYS4 CNC Controller		G54 M3 M9 M11	

### 5.10.2 Spindle adjustment

In the feed adjustment mode, press the [Parameter Switch] to enter the spindle adjustment mode, at this time the spindle adjustment font is thickened, this time press [A] to increase the spindle adjustment value, press [A-] to decrease the spindle adjustment value, the step value is 10%.

Current spindle speed S#=set spindle speed S\*spindle correction.

连续	空闲	2mmnew.tap	00:01:06
X	-9.441 mm	<b>-9.441</b> mm	进给修调 120%
Y	-42.225 mm	<b>-42.225</b> mm	主轴修调 120%
Z	4.749 mm	<b>4.749</b> mm	手控修调 100%
A	0.000 mm	<b>0.000</b> mm	F 0 3000
3137: X-11.278Z-0.196		S 16800 5777	
主控页面		文件页面 配置页面	
JYS4 CNC Controller		G54 M3 M9 M11	

### 5.10.3 Manual adjustment

Manual rate adjustment is to adjust the manual rate adjustment parameters. Press the [Parameter switch] once to enter the manual rate adjustment mode under the spindle adjustment mode. At this time, the manual rate adjustment font is thickened. In the "continuous" mode of the feed state, press [A] to increase the manual adjustment value, press [A-] to decrease the manual rate adjustment value, and the step value is 10%. As shown in the figure below, the manual rate value is reduced to 80%.

Current manual rate FS#=set hand control speed FS\*hand control trim.

连续	空闲	2mmnew.tap	00:01:06
X	-9.441 mm	<b>-9.441</b> mm	进给修调 120%
Y	-42.225 mm	<b>-42.225</b> mm	主轴修调 120%
Z	4.749 mm	<b>4.749</b> mm	手控修调 80%
A	0.000 mm	<b>0.000</b> mm	F 0 3000
3137: X-11.278Z-0.196		S 16800 5777	
主控页面		文件页面 配置页面	
JYS4 CNC Controller		G54 M3 M9 M11	

In the "inching" mode of the feed state, the hand control adjustment at this time represents the step value of inching.

手动	空闲	2mmnew.tap	00:00:00
X	-18.378 mm	<b>-18.378</b> mm	进给修调 120%
Y	-43.825 mm	<b>-43.825</b> mm	主轴修调 120%
Z	4.767 mm	<b>4.767</b> mm	手控修调 0.01
A	0.019 mm	<b>0.019</b> mm	F 0 3000
3137: X-11.278Z-0.196		S 0 5777	
主控页面		文件页面 配置页面	
JYS4 CNC Controller		G54 M5 M9 M11	

### 5.10.4 F value adjustment

F value adjustment is to adjust the default feed rate, press the [Parameter switch] key once in the hand control adjustment mode to enter the F mode, at time the F font becomes bold, indicating that F is in the editable state, as shown in the figure:

手动	空闲	2mmnew.tap	00:00:00
X	-9.441 mm	<b>-9.441</b> mm	进给修调 100%
Y	-42.225 mm	<b>-42.225</b> mm	主轴修调 100%
Z	4.749 mm	<b>4.749</b> mm	手控修调 0.01
A	0.000 mm	<b>0.000</b> mm	F 0 3000
3137: X-11.278Z-0.196		S 0 5777	
主控页面		文件页面 配置页面	
JYS4 CNC Controller		G54 M5 M9 M11	

In F modification mode, press the [A] key to make the F value font bold, then the default F value is the current machining speed of the speed specified by the G code, press this value again to make it non-bold, then cancel it as the current machining speed, and the system will follow the code instruction, as shown in the above picture, the current running speed is set to 3000.

In the F modification mode, press [A-] to enter the default F value modification mode, and the editable text box will pop up at time, and the prompt information area has prompted the X, X-, Y, Y-, Z, Z- functions. At this time, press [X-] to move the cursor one position to the left, press [X] to move the cursor one position to the right, press [Y] to designate the current position 1, press [Y-] to designate the current position value -1, press [Z] to cancel the current value modification, press [Z-] to the current value modification. Modify the F value to 2900 as shown in the figure, and after the modification is confirmed as shown in Figure 3-3, the current default F value becomes 2900.

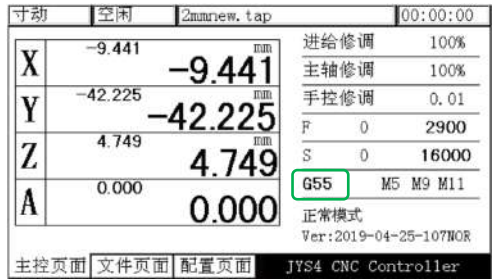
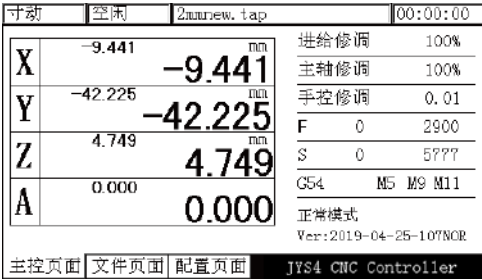

5.10.5 S value modification



S value adjustment is to adjust the default spindle speed, press the [Parameter Switch] once to enter the S mode under the F adjustment mode, this time the S character becomes bold, as shown in the figure. In the S modification mode, press the [A-] to enter the default S value modification mode, at time the editable text box pops up, and the prompt information area has prompted the X, X-, Y, Y-, Z, Z- functions. this time, press the [X-] to move the cursor one position to the left, press the [X ] to move the cursor one position to the right, press [Y ] to designate the current bit value 1, press the [Y-] to designate the current bit value -1, press the [Z ] to the current value modification, press the [Z-] to confirm the current value modification.

5.10.6 Select G coordinate system

In the S modification mode, press [Parameter Switch] to enter the coordinate system selection mode, at this time, the coordinate system coefficient value will become bold at this time, press [A ] to increase the coordinate system coefficient value, press [A-] to decrease the coordinate system coefficient value, as shown in the figure, current coordinate system before modification is G54, press 1 [A ] after, as shown in the figure, the current coordinate system after modification is G55.

VI. Second function

The second function is some auxiliary functions other than automatic machining, including returning the workpiece to zero, clearing the current coordinates, finding the mechanical coordinate zero setting the tool, you must press the [Second Function] button to enter the second function mode, and then perform other operations. The specific operation methods of the four second functions are below.

6.1. Return to zero

In the normal standby state (the operation status bar displays idle, and the prompt information bar displays "Normal Mode"), press [Second Function] enter the second function mode, at which time the prompt information bar displays: X-: Return to Zero; Y-: Clear Zero; Z-: Seek Zero; X Center X; Y : Center Y; Z : Touch Off, the feed status bar displays "Second Function", and press [X-] once more to enter the to workpiece zero mode. In the "Return to Zero" mode, you can enter 2 modes:

A: In the "return to zero" mode, pressing [X ] or [Y ] or [Z ] or [A ] will start the function of returning each single axis X, Y, Z, A to 0 or running to the designated coordinate. Here we take the X axis as an example and press [X ],At this time, the feed state bar still displays "return to zero", and the prompt message bar displays: X : move left; X-move right; Y : move up; Y-: move down; Z-: confirm; Z : cancel. At this time, if you press [Z-], the X-axis will return to 0, and if you enter the coordinate value in the pop-up dialog box and then press [Z-], the X- will move to the input coordinate axis position. Set the coordinate to 100, as shown in the figure, press [Z-] after the X-axis moves to position 100.



B: In the "return to zero" mode, pressing [X] again will return all axes to the workpiece's zero point. At time, the system will first run the X, Y, and A axes to protect the main spindle, and then run the Z axis to zero. Since the system's default height for the Z axis is 5, the Z axis will be raised to coordinate 5, as shown in the figure below.



### 6.2. Reset to zero

In the normal standby state (the operation status bar displays "Idle", and the prompt information bar displays "Normal Mode"), press [Second Function] to enter the second function mode, at which time the prompt information bar displays: X-: Return to Zero; Y-: Clear Zero; Z-: Seek Zero X : Center X; Y : Center Y; Z : Touch-off. The feed status bar displays "Second Function" as shown in the figure. Press [-] once again to enter the current coordinate zeroing mode, at which time the feed status bar displays "Zeroing". In the "Zeroing" mode, you can 2 modes:



A: In the "zero" mode, press [Y-] again, all current coordinates are cleared to 0, then exit the "second function" and return to the "idle" state, all current coordinates are cleared to 0.



B: In the "zero" mode, pressing [X] or [Y] or [Z] or [Z] will start X, Y, Z, A single-axis coordinate zeroing or modify it to the specified coordinate value. Here we take the X-axis as an example. If you do enter any numbers and press [X] directly, the X-axis coordinate zeroing function will be started; if you enter the corresponding number, such as 100 and then press [Z-], the X-axis coordinate will display the current position as 20. After confirmation, the X coordinate value is 20 as shown the following figure:



### 6.3 Zero-seeking

In the normal standby state (the operation status bar displays "Idle"), press [Second Function] to enter the second function mode, at time the prompt message bar displays: X-: Return to Zero; Y-: Clear Zero; Z-: Seek Zero; X : Center X; Y : Center; Z : Touch Off. The feed status bar displays "Second Function", as shown in the figure below. At this time, press [Z-] once to enter mechanical zero point search mode, at which time the feed status bar displays "Seek Zero", as shown in the figure:



A: In the "seek zero" mode, pressing [Z-] again can start the function of seeking the mechanical zero point of all axes, order of seeking zero is Z/X/Y/A, and the order is Z/X/Y without the A axis.

B: In the "seek zero" mode, pressing the corresponding axis selection key can start the single-axis seeking mechanical zero point function. Here we take X-axis as an example, press the X-axis selection button, at this time, the X-axis moves continuously in the negative direction until the zero point switch is closed then decelerates and stops, and then returns to the position where the zero point switch is disconnected, and the machine coordinate X-axis is set to 0

After the X-axis has found the zero position, it will retract 10mm, and the entire X-axis mechanical zero search function will be.

### 6.4 X in the middle of the minute

In the normal standby state (the operation status bar displays "Idle"), press [Second Function] to enter the second function mode, at time the prompt message bar displays: X-: Return to Zero; Y -: Clear Zero; Z-: Seek Zero; X : X Axis Workpiece Coordinate Dividing; Y : Y Axis Workpiece Coordinate Dividing; Z : Tool Setting. The feed status bar displays "Second Function", at which time [X ] once to execute the X-axis workpiece coordinate dividing function.

### 6.5 Y in the middle of the minute

In the normal standby state (the operation status bar displays "Idle"), press [Second Function] to enter the second function mode, at which time the prompt message bar displays: X-: Return to Zero; Y-: Clear Zero; Z-: Seek Zero; X : X Axis Workpiece Coordinate Dividing; Y : Y Axis Workpiece Coordinate Dividing; Z : Tool Setting. The feed status bar displays "Second Function", at which time press [X ] once to execute the X-axis workpiece coordinate dividing function.

### 6.6 Set the tool

Long-term use can cause the tool to wear out, or after changing the tool, the position relationship between the tool tip and the motor will change, will directly affect the machining quality of the workpiece. In this case, it is necessary to adjust the tool to determine the new tool tip offset. The JYS4 system a fixed position tool setting mode and a floating tool setting mode, and the factory default setting is the fixed tool setting mode.

**Model one: fixed position tool setting mode.** In this mode, two times of tool setting are required to complete the tool setting operation. The first tool setting measures the thickness of the tool setting block and it in the system, and the

second tool setting can determine the position of the new workpiece. In short, this mode of tool setting operation consists of a total of 3, including setting the workpiece coordinate system, the first tool setting, and the second tool setting after tool change or confirmation of tool wear. The operation steps are as follows :

Step 1: Set the workpiece coordinate system;

Step 2: The specific operation method is as follows: press the [Second Function] key to enter the second function state, and then press the [Z] key to start the tool setting. The system will automatically move to the mechanical coordinate position and start to search down for the tool setting block and then perform the tool setting ;

Step 3: If tool change or re-positioning of the Z -axis is required after confirming tool wear, perform a second tool setting, following the procedure as above.

**Model two: floating tool setting mode.** In this mode, the workpiece setting can be completed by performing a single touch-off operation, but before the workpiece setting, it is necessary to configure thickness of the #69 workpiece setting block into the system. The operation steps are as follows :

Step 1: Set the workpiece coordinate system;

Step 2: Measure the thickness of the touch-off block and find #69 in the page, then enter the value;

Step 3: Perform touch-off, press [Second Function] to enter the second function state, and then press the [Z key to start floating touch-off;

## VII、Parameter Backup and Upgrade

### 7.1 Parameter Backup

Many users hope to save their custom parameter tables and apply them to multiple controllers of the same model after setting them up. Let's introduce the operation steps below:

After turning on the controller, plug in the USB flash drive, enter the file page, select the folder as shown in the figure below, the "mnt folder is the system folder, please note that everyone must not delete any files in this folder at will; find the parameter setting storage file "setting" in the system folder; then the setting file to the USB flash drive.

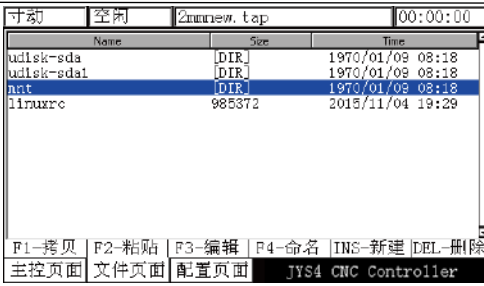

and setting is the configuration item file. We generally include files when we release the upgrade package. After the upgrade, all configurations will be initialized. If customers need to keep the previously set configuration items, please replace the setting file backed up the system with the one in the firmware package.

Special attention must be paid to ensure that the upgrade files are placed in the install folder under the USB drive in order to upgrade correctly. If there are multiple levels directories or the install directory name is incorrect, the upgrade will not be possible.

After the correct upgrade file is on the USB flash drive, plug the USB flash drive into the device without power, then power the device on. The program will automatically upgrade the product software. During the upgrade process, the device interface will remain on the startup page until the upgrade is complete, which will take about 30 seconds. Please be patient and do not power off or perform other operations during the upgrade process. After the upgrade is completed, the version number will be displayed in the lower right corner of the page. You can determine whether the upgrade is successful based on this number.

After the upgrade is completed, be sure to remember to remove the USB drive from the offline controller. If you need to keep the USB drive plugged into the for work, delete this installation file. Otherwise, when the user starts the offline controller again, the system will detect the install directory and continue to upgrade again. The previously set parameters, etc., will be overwritten, and the system data will return to the initialized state.

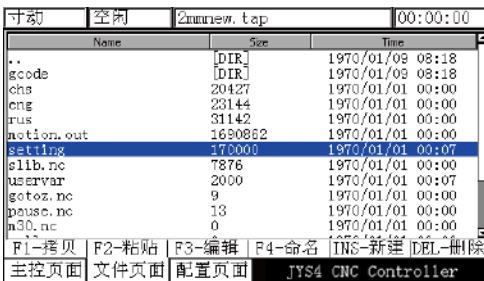
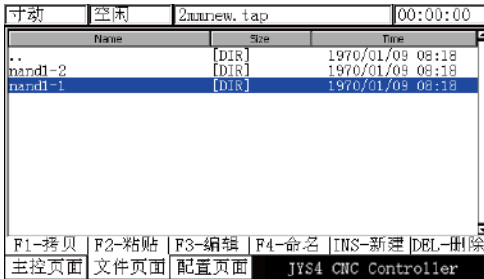

## 7.2 System upgrade

As shown in the figure, each upgrade package file name contains the version number. After the upgrade, this version number will appear in the lower right corner of the's main interface. Please check whether the version number is consistent after the upgrade.

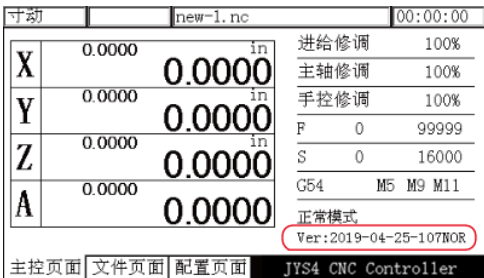

Upgrade the package directly to U. The upgrade file contains a total of 6 files, where the chs and eng files manage Chinese and English, respectively. motion.out is the main program, pause.nc and systemlib.nc are the extended instruction files,

## VIII、maintenance of the electrical control box

Dust can easily accumulate inside the control box and machine during operation, especially when processing metal materials. Metal conductive dust, once it enters the control box can cause short circuits or burn out circuits. Therefore, it is recommended to regularly clean the inside of the control box.

During operation, you can first open the control box housing, use a hairdryer set to the cold air setting or a cold air gun, invert box, and blow away the dust on the surface of the circuit board and components. For corners that are difficult to clean, you can gently wipe them with a small brush to ensure removal of conductive dust. After cleaning, make sure the interior is completely dry before closing the lid and restarting the equipment.

The information contained in this manual is for reference only and does not constitute any operational specification or technical guarantee. Due to the differences in actual equipment models, usage environments, and specific working conditions, users must adjust and judge based on the current state of the equipment during actual commissioning and use. For special cases or technical issues not covered the manual, please do not deal with them on your own, and should contact the manufacturer or authorized service provider to seek professional support. Product specifications and information are subject to change without notice, and the manufacturer also reserves the right to improve and interpret the products and documents at any time. The manufacturer shall not be liable for any consequences directly or indirectly caused by not this statement.

## IX、Code support

### 9.1 G code

Crystal engraving machine equipment commonly used G code recognition processing, commonly used G code can refer to Appendix I.

### 9.2 M code

The crystal engraving machine equipment is also commonly identified and processed with M codes, and the commonly used M codes can be referred to Appendix II.

The information contained in this manual is for reference only and does not constitute any operational specification or technical guarantee. Due to the differences in actual equipment models, usage environments, and specific working conditions, users must adjust and judge based on the current state of the equipment during actual commissioning and use. For special cases or technical issues not covered by the manual, please do not deal with them on your own, and should contact the manufacturer or authorized service provider to seek professional support. Product specifications and information are subject to change without prior notice, and the manufacturer also reserves the right to improve and interpret the products and documents at any time. The manufacturer shall not be liable for any consequences directly or indirectly caused by not following this statement.

扫描“晶研科技”微信小程序二维码，获得售后支持



## Appendix I :

G-Code	Instruction Name	Instruction Explanation	G-Code Example
G00	Rapid Positioning	Move to the specified position at the system's highest set speed.	G00 X10 Y20 Z30
G01	Linear Interpolation	Move to the specified position at the feed rate (F) specified by the system or the file.	G01 X50 Y60 F150
G02	Circular Interpolation CW	Clockwise circular cutting machining.	G02 X100 Y100 I20 J20
G03	Circular Interpolation CCW	Counterclockwise circular cutting machining.	G03 X100 Y100 I20 J20
G04	Dwell	Pause. When used with P, specifies the pause time in milliseconds.	G04 P200
G17	XY Plane Selection	Selects the XY plane for interpolation.	G17
G18	ZX Plane Selection	Selects the ZX plane for interpolation.	G18
G19	YZ Plane Selection	Selects the YZ plane for interpolation.	G19
G20	Inch Input	/	G20
G21	Millimeter Input	/	G21
G28	Return to Reference 1 via Intermediate Point	<p>1.If the corresponding axis is not configured with a zero signal, the instruction for that axis is ignored.</p> <p>2.If all axes have completed the HOME operation, move to the intermediate point first, then return to reference point 1.</p> <p>3.If the HOME operation has not been completed, move to the intermediate point first, then perform the HOME operation.</p>	<p>1.G90G28X10Y10Z10A10(First move to workpiece coordinate (0,0,0,0), then return to reference point 1)</p> <p>2. G91G28Z0(Z-axis returns to the Z position of reference point 1 from the current position)</p>
G30	Return to Reference P via Intermediate Point	The P word takes values 1, 2, 3 to specify which reference point to return to. Usage is similar to the G28 instruction.	G90G30X10Y10Z10 A10P
G31	Probe.During the instructed movement, if the probe signal is detected at the specified level, the movement stops (stop mode can be configured for immediate stop or deceleration stop).	<p>XYZA specify probe travel for each axis. L specifies the effective probe signal level. K specifies whether hard limits are disabled during probing: 0-Disabled; 1-Not disabled</p> <p>Q specifies the stop method after probe signal appears: 0-Deceleration stop; 1-Immediate stop. F specifies the probe</p>	G91G31Z-1000L0Q1K0F100(Z-axis probes downward 1000mm, probe signal effective level 0, hard limits disabled during probing, immediate stop upon probe signal.)
G53	Machine Coordinate System Move	The corresponding configured axis must have completed the HOME operation, otherwise the program alarms and exits.	G53X10Y10(XY axes move to machine coordinate (10,10))
G54	G54 Coordinate System	Selects the G54 workpiece coordinate system.	G54
G55	G55 Coordinate System	Selects the G55 workpiece coordinate system.	G55
G56	G56 Coordinate System	Selects the G56 workpiece coordinate system.	G56
G57	G57 Coordinate System	Selects the G57 workpiece coordinate system.	G57
G58	G58 Coordinate System	Selects the G58 workpiece coordinate system.	G58
G59	G59 Coordinate System	Selects the G58 workpiece coordinate system.	G59

G-Code	Instruction Name	Instruction Explanation	G-Code Example
G73	High-Speed Peck Deep Hole Drilling Cycle	Deep hole drilling cycle, used with F, X, Y hole position data; Z_ distance from R point to hole bottom; R_ distance from initial position to R point; Q_ cutting depth per feed; P_ dwell time; K_ repeat count.	G73X_Y_Z_R_Q_F_K_
G73	High-Speed Peck Deep Hole Drilling Cycle	Deep hole drilling cycle, used with F, X, Y hole position data; Z_ distance from R point to hole bottom; R_ distance from initial position to R point; Q_ cutting depth per feed; P_ dwell time; K_ repeat count.	G73X_Y_Z_R_Q_F_K_
G74	Left-Hand Tapping Cycle	The spindle must be configured as a servo spindle. G74 will reverse at the set speed to the hole bottom (Z) then forward back to the R point. G84 will forward at the set speed to the hole bottom (Z) then reverse back to the R point. X, Y hole position data; Z_ distance from R point to hole bottom; R_ safety plane; P_ dwell time.	G98/G99 G74 X_Y_Z_R_P_F_
G84	Right-Hand Tapping Cycle	The spindle must be configured as a servo spindle. G74 will reverse at the set speed to the hole bottom (Z), then forward back to the R point. G84 will forward at the set speed to the hole bottom (Z), then reverse back to the R point. X, Y hole position data; Z_ distance from R point to hole bottom; R_ safety plane; P_ dwell time.	G98/G99 G84 X_Y_Z_R_P_F_
G81	Drilling Cycle	Drilling cycle, used with F, X, Y hole position data; Z_ distance from R point to hole bottom; R_ distance from initial position to R point; F_ cutting feed rate; K_ repeat count.	G81 X_Y_Z_R_F_K_
G82	Boring Cycle	Boring cycle, used with F, X, Y hole position data; Z_ distance from R point to hole bottom; R_ distance from initial position to R point; F_ cutting feed rate; K_ repeat count; P_ dwell time at hole bottom.	G82X_Y_Z_R_P_F_K_
G83	Peck Deep Hole Drilling Cycle	G83 retracts rapidly to the hole bottom between feeds. X, Y hole position data; Z_ distance from R point to hole bottom; R_ distance from initial position to R point; Q_ cutting depth per feed; F_ cutting	G83X_Y_Z_R_Q_F_K_
G90	Absolute Programming	In G90 input programs, all machining operation points start from the same initial point.	G90
G91	Incremental Programming	In G91 input programs, all machining operation points are relative to the previous machining point, representing a relative coordinate increment.	G91

## Appendix II :

M-Code	Instruction Name	Instruction Explanation
M00	Program Stop	Pause
M03	Spindle Forward (CW)	Spindle forward output control signal set active.
M04	Spindle Reverse (CCW)	Spindle reverse output control signal set active.
M05	Spindle Stop	Spindle forward output control signal set inactive.
M08	Coolant On	Coolant output control signal set active.
M09	Coolant Off	Coolant output control signal set inactive.
M10	Lubrication On	Lubrication output control signal set active.
M11	Lubrication Off	Lubrication output control signal set inactive.
M29	Rigid Tapping Mode	Enter rigid tapping mode, called before G74/G84 instructions.
M30	Program End and Reset	Ends all instructions.
M105	X-axis Homing Command	If these commands appear on the same line, it indicates the corresponding axes perform homing simultaneously.
M106	Y-axis Homing Command	
M107	Z-axis Homing Command	
M108	A-axis Homing Command	

## SERVICE

E-Mail: [support@jingyan.tech](mailto:support@jingyan.tech)

Website: <http://www.jingyan-tech.com/>





 注意安全!

 当心触电!

 注意强磁场!

 佩戴护目镜!

 阅读说明书!

 请勿将用电器丢入垃圾桶!