

PUBLIC ADDRESS / SPEAKERS / CEILING

SKY-8T-DOME

8' + 1' CEILING LOUDSPEAKER WITH 100 V LINE TRANSFORMER AND LOW IMPEDANCE



- ✔ 8' + 1' coaxial speaker. 30/15/7.5/3.75 W RMS@100 V and 30 W RMS@8 Ω.
- ✔ Low profile aluminium grille
- ✔ Fast connection terminals and high conductivity. In junction box
- ✔ Anti-fall system for installation assistance



+ Info:
<https://fonestar.com/SKY-8T-DOME>

ESPECIALLY RECOMMENDED IN:



Hospitality



Retail



Hotels



All sectors

DESCRIPTION

8" coaxial ceiling speaker with 1" tweeter and rear dome cover. 30/15/7.5/3.75 W RMS@100 V and 30 W RMS@8 Ohm. Low profile grille.

TECHNICAL CHARACTERISTICS

FEATURES	<p>Ceiling loudspeaker with 100 V line transformer and low impedance. Protective dome type back cover. Low profile frameless grille, constructed from rust resistant aluminium. Detachable, turn-lockable grille. The logo can be removed and painted. Fast connection terminals and high conductivity. Junction box in the rear cover with inlet and outlet port. Anti-fall system for installation assistance. Hook for safety cable. Stable, worm-gear ceiling brackets. Installation in ceilings with limited space. Protection against dust and water.</p>
POWER	<p>30 W RMS 40 W MAX.</p>
SPEAKER	<p>Coaxial speaker. 8" polypropylene woofer 1" adjustable tweeter</p>
RESPONSE	<p>90-20,000 Hz @ -10 dB 100-20,000 Hz @ -3 dB</p>
IMPEDANCE	<p>30 W RMS@100 V (333 Ohm) 15 W RMS@100 V/70 V (666 Ohm/326 Ohm) 7.5 W RMS@100 V / 70 V(1.333 Ohm/ 653 Ohm) 3.75 W RMS@100 V / 70 V(2.666 Ohm/ 1.306 Ohm) 1.87 W RMS@70 V (2.620 Ohm) Low Z: 8 Ohm</p>
SENSITIVITY	<p>90 dB @ 1 W/1 m</p>
SOUND PRESSURE	<p>108 dB @ max. W/1m Continuous 109 dB @ max. W/1m Peak</p>



+ Info:

<https://fonestar.com/SKY-8T-DOME>

COVERAGE ANGLE:	90°@1kHz (-6 dB)
PROTECTIONS	IP-65 in compliance with IEC 60529 EN ISO 9227:2006 Neutral Salt Spray Test
MATERIAL	ABS (UV resistant) Liquid painted aluminium grille
CONNECTORS	Quick-connect terminals with high conductivity Conductor cross-section: 0.4-4 mm ² Rubber cable glands for round cables with a diameter of 6-7 mm
SWITCH	W selector in high Z and 8 Ohm. Accessible from the front.
OPERATION TEMPERATURE	-20°C ~ 70°C (48 h)
STORAGE TEMPERATURE	10°C ~ 40°C
MAXIMUM HUMIDITY	95%
COLOUR	White (RAL 9003)
DIMENSIONS	Total loudspeaker: 306 mm Ø x 128 mm height Grille section: 7 mm Recessed height: 121 mm Installation hole: 273 mm Ø Maximum ceiling thickness: 30 mm
WEIGHT	2.4 kg
ACCESSORIES	Installation template



+ Info:

<https://fonestar.com/SKY-8T-DOME>

• **SPL vs Frequency**

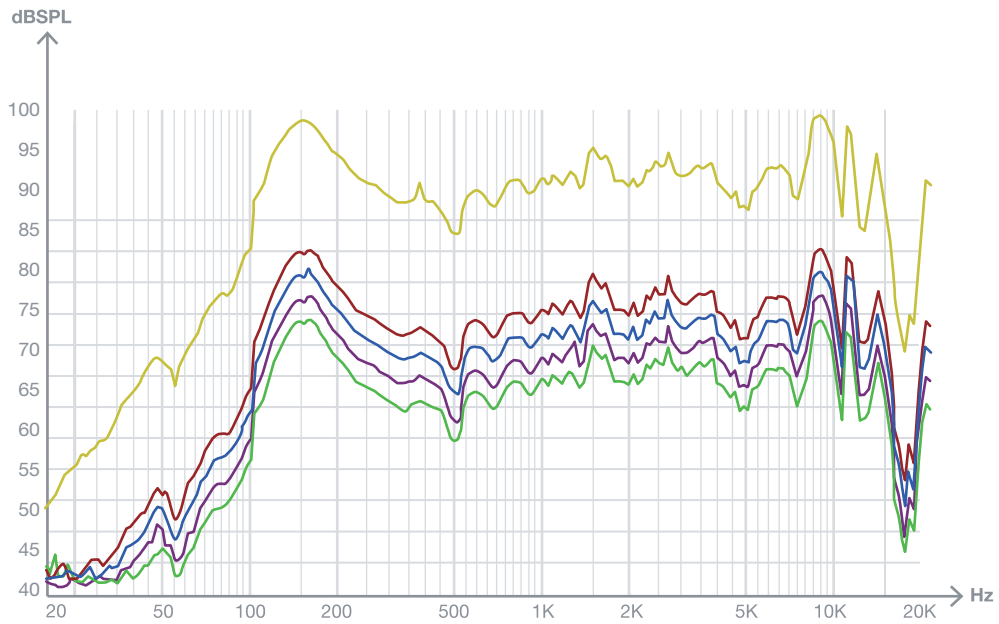

• **SPL vs Angle**

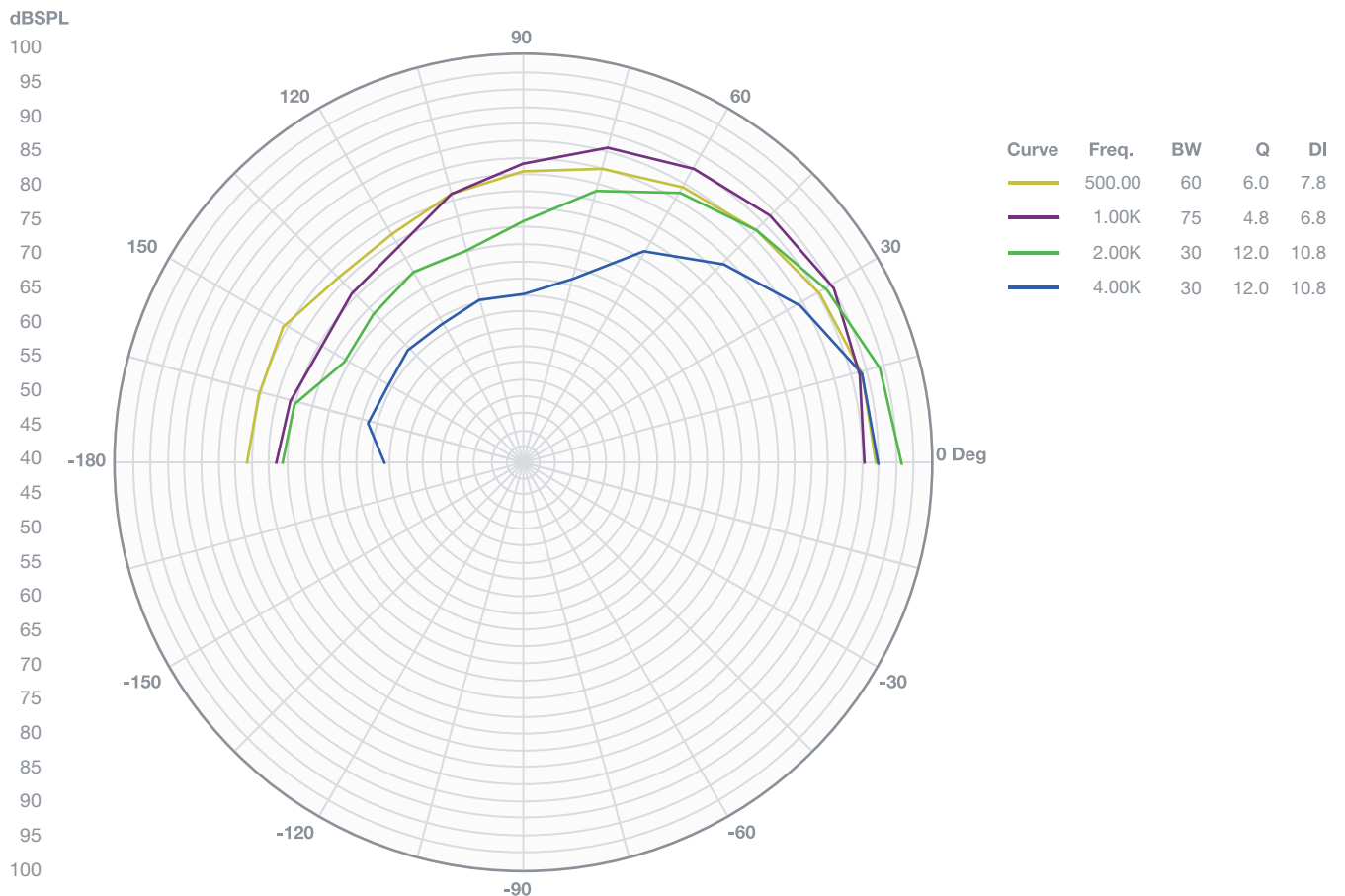

●  Impedance vs Frequency

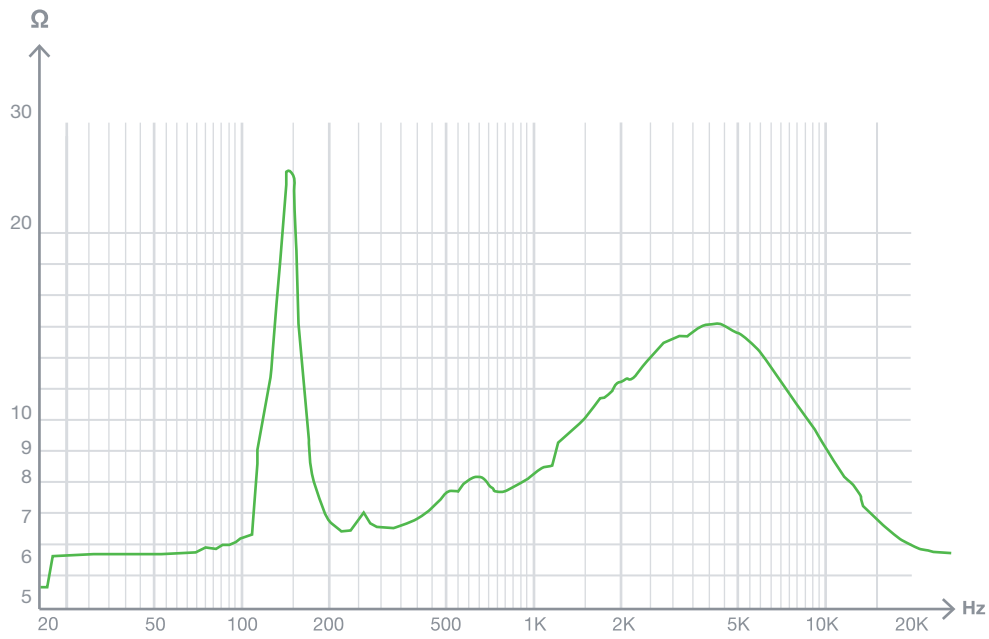

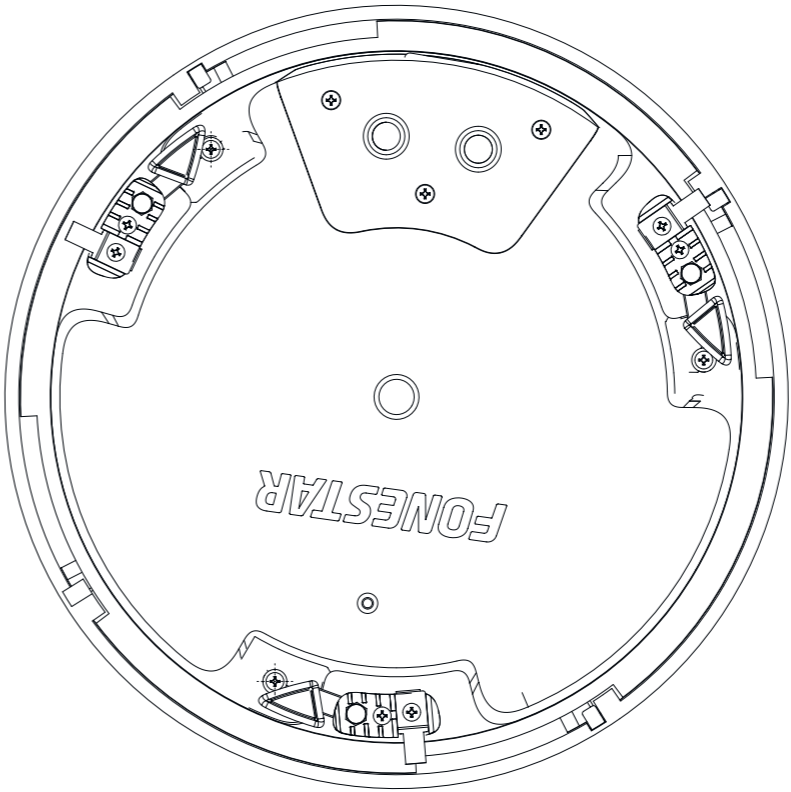
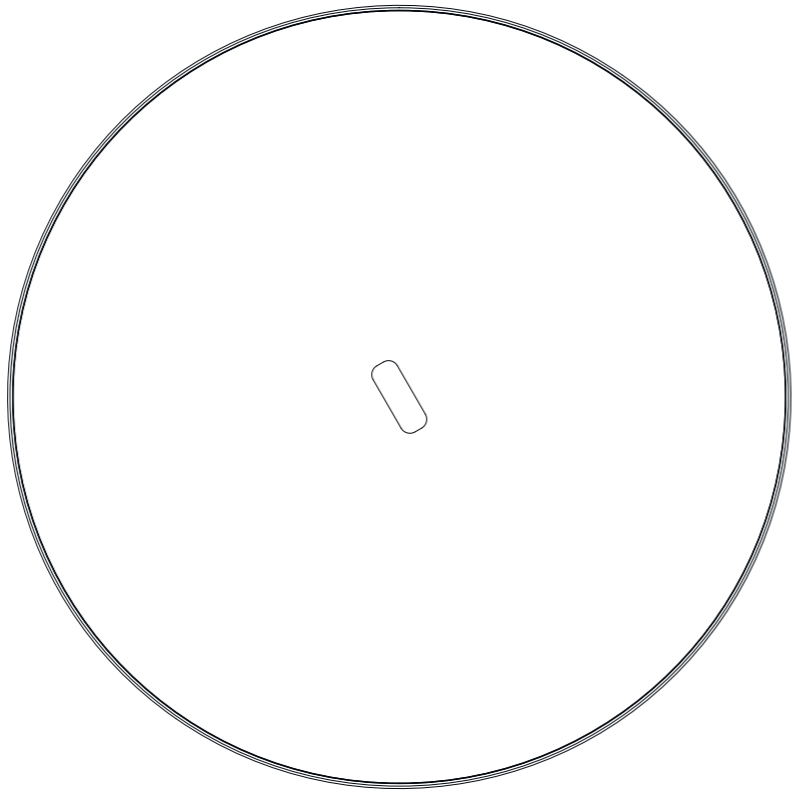
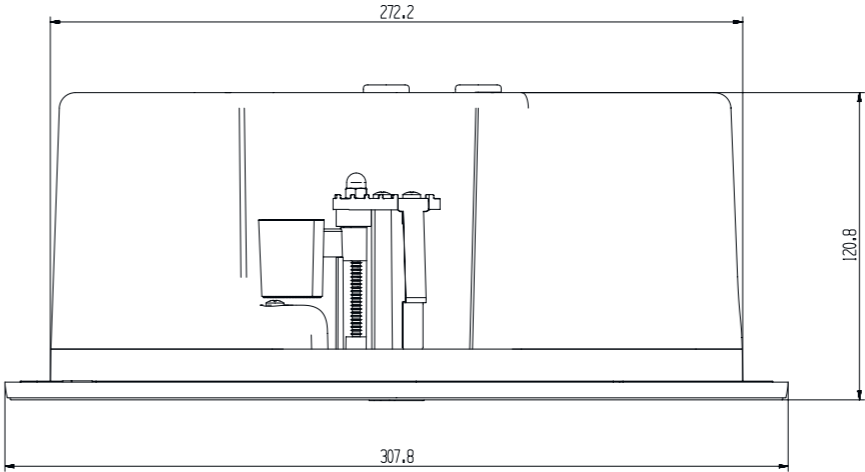

Product:
SKY-8-DOME + SKY-8T-DOME Line Drawings

Date: 2025-06-12

FONESTAR

www.fonestar.es