

## Air separator



Brass air separator

Plastic air separator

### Application in HVAC water systems:

In the HVAC water pipeline system, the pipeline is filled with air before water injection is completed. After water injection, the accumulated air in the pipeline cannot be discharged properly due to the unreasonable direction of the pipeline. Some air cannot be discharged due to the improper position of the exhaust valve installation. Under normal circumstances, the amount of dissolved air in water decreases with increasing temperature, and increases with increasing pressure. In fact, even if we have already discharged the air from the pipeline before debugging, due to the changes in water temperature and pressure during actual operation, a large amount of gas will still be released in the system. The higher the water temperature and pressure, the smaller the amount of air released in the water, which is also the reason for the continuous presence of air in our water system. The presence of gas in the water pipeline can cause a decrease in system heat transfer efficiency, water system noise, pipeline oxidation and corrosion, local overheating or non heating, water pump cavitation, insufficient water flow, water flow switch shaking, increased energy consumption of the air conditioning host, decreased energy efficiency, and in severe cases, frequent water flow alarms and damage to the host, as well as damage to other pipeline components. The gas in the water system pipeline often exists in the form of bubbles and has not completely decomposed into gas. Therefore, ordinary automatic exhaust valves cannot discharge a large amount of gas in the water when applied to the inlet and outlet or main pipeline of boilers or air conditioning heat pump hosts. The AS10 series spiral microbubble exhaust valve is designed to address the above issues and can continuously and effectively automatically eliminate gases present in the system. It is widely used in HVAC water systems.

### Characteristic:

Air separator adopts a special exhaust structure design, with a limit on the floating ball at its top to ensure a certain distance from the floating ball to the exhaust valve cover. This feature effectively prevents impurities floating in the water from blocking the exhaust sealing port, resulting in water dripping at the exhaust port. This ensures that Air separator can exhaust normally even in harsh water conditions, and the large capacity chamber also reduces pressure fluctuations.

### Working principle:

When the water flow in the pipeline passes through Air separator, the diameter of Air separator is much larger than the connected pipeline. Once the water enters Air separator, the flow rate is greatly reduced. At this time, the small bubbles carried in the water quickly fuse together when they encounter the specially designed spiral needle net in Air separator. Due to the buoyancy effect, they rise to the exhaust chamber, causing the floating ball with a positioning pin at the upper end of the exhaust chamber to rise and open the exhaust port, Remove the air.

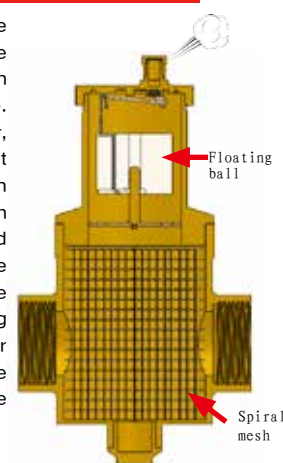

### Technical Parameter:

- Max pressure: 10bar (brass) , 6bar (plastic)
- Maximum exhaust pressure: 10bar
- Maximum operating temperature (Water): 110°C (brass) , 90°C (plastic)
- Maximum concentration of ethylene glycol aqueous solution: 50%
- Drift diameter: DN20,25,32,40,50, DN25 (plastic)
- Valve body: brass/plastic
- Floating ball: PP

### Model Selection Table:

				Description
AS1	020	A	A	Air separator
	020			thread: G3/4"
	025			thread: brass body G1" /plastic male thread G1-1/4"
	032			thread: G1-1/4"
	040			thread: G1-1/2"
	050			thread: 2"
		A		body material: brass
		P		body material: plastic
		S		body material: sus304
			A	thread type: female thread
			C	thread type: male thread

**Model and external dimension diagram:**

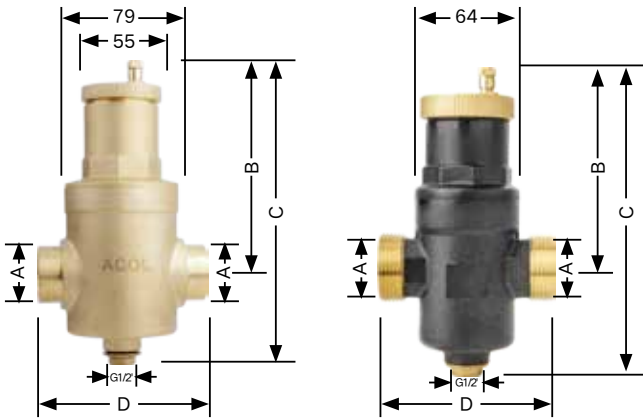

Model	Size	A	B	C	D
AS1020	DN20	3/4"	141	207	115
AS1025	DN25	1"	119	184	104
AS1025PC	DN25	1-1/4"	141	207	115
AS1032	DN32	1-1/4"	141	207	115
AS1040	DN40	1-1/2"	141	207	115
AS1050	DN50	2"			

**Installation and maintenance:**

■ Air separator can be installed on the supply and return water pipes of the water system, but the exhaust port must be at the top. For heating systems, installing it at the highest temperature position is beneficial for exhaust, such as the outlet of a boiler. For water pumps and heat exchangers, installing them slightly further away from their inlet can reduce gas entering the water pump and heat exchanger, which is beneficial for the normal operation of these components.

Connecting pipe diameter	DN20	DN25	DN32	DN40	DN50
Max flow rate m <sup>3</sup> /h	1.36	2.11	3.47	5.42	8.20
Recommended max cooling capacity kW	8	12	20	32	50

■ Air separator is specifically designed for use in heat pump water systems using R290 refrigerant. It has an extremely large exhaust capacity. When the plate is frozen and the refrigerant enters the water system, Air separator quickly removes the gas refrigerant from the water, avoiding safety accidents. It is best to install Air separator at the plate exchange outlet.

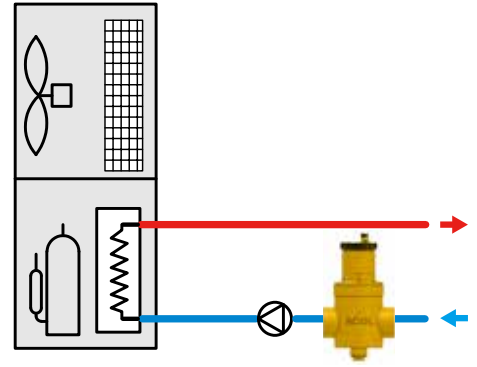
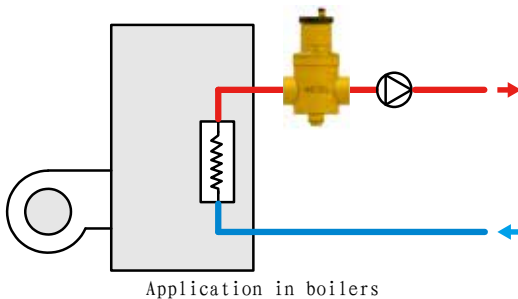

Application in air conditioning and heat pumps

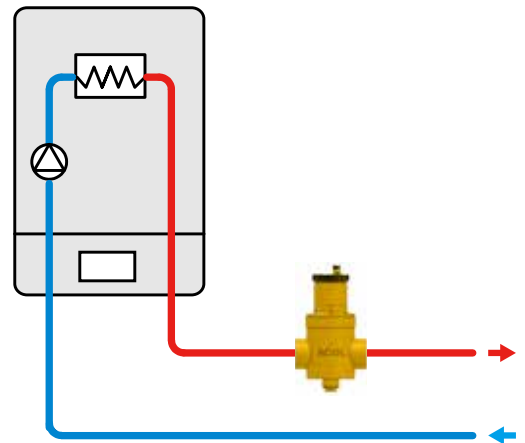

Application in wall mounted furnaces

■ The structural design of Air separator has taken into account maintenance and cleaning. There is no need to disassemble the entire spiral microbubble exhaust valve from the pipeline. Simply open the top exhaust valve cover to clean the exhaust seal and floating ball and other moving parts. If you want to further clean the exhaust chamber, you can unscrew the exhaust valve to clean the inner chamber and spiral needle mesh, and clean the garbage on the spiral needle mesh.

