

ENGINEERED WOOD

Guide



PARADOR

Table of contents

03	Applications
03	The right choice
06	Engineered wood and room climate
07	Product structure
08	Technology
09	Accessories
13	Installation at a glance
14	Installation rules
19	Subfloor requirements
20	Installation options
22	Assembling engineered wood with Automatic-Click® system
	› Basic 11-5; Classic 3025, 3060; Selected; Trendtime 4, 6, 8; Selected; Edition Harmonia
26	Assembling engineered wood with Allround-Click® system
	› Trendtime 3 (herringbone); Selected
28	Assembling engineered wood glued over the whole area with tongue and groove connection
	› Chevron
32	Retaining value, cleaning and care, including flooring with lacquer surface extra matt professional

Checklists

36	Acceptance protocol template
37	Underfloor heating system
39	Whole-area gluing

Allround-Click®, Automatic-Click®: Registered as a Union Trademark

You will find important information about installation on the pack leaflets or, if applicable, on the product packaging or in available product-specific instructions. For special applications, additional information is also available through Parador Application Technology.

Please also pay attention to the technical data sheets, declarations of performance, certificates and installation videos, which you will find on the Parador website www.parador.de/en.

The following standards are also relevant for the use of Parador engineered wood:

DIN 18202	Tolerances in building construction
DIN 18299	General conditions for construction work of any kind
DIN 18365	Flooring work
BEB publication	Evaluation and preparation of substrates; heated and unheated floor constructions

Applications

Possible applications

With Parador engineered wood, your ideas are quickly and easily turned into reality, because these high-quality engineered wood floors can be installed perfectly in no time at all thanks to the patented Automatic-Click® and Allround-Click® systems as well as proven tongue and groove connection. Engineered wood from Parador combines naturalness with exclusivity, and is also very durable. The large selection of exquisite wood types in different formats and installation patterns in various assortments offers the right product for every area and every style. Parador engineered wood can be used in all living areas, but also in offices and commercial premises, depending on use. The flooring is not suitable for use in wet rooms (for further information, please refer to the section: 'Installation in wet rooms' in the chapter 'Installation rules').

The right choice

Not all engineered wood is the same. Before buying, you should check which engineered wood suits you best. In addition to the type of wood, the visual requirements of the assortment and the thickness of the top layer, the quality of the connection (click connection and tongue and groove connection) and the surface finish play a particularly important role. With Parador, you have the choice between oil impregnation, pure natural oil and a multi-layer lacquer finish. Whether you opt for lacquered or oiled engineered wood and combine this with the desired colours before selecting the specific wood is (almost) purely a matter of taste. Here are the advantages and disadvantages at a glance.

Natural oil plus engineered wood, naturally oiled engineered wood, and oil-impregnated (UV oil) engineered wood

The Parador oil impregnation (UV oil) is a very effective surface treatment, which unlike other oil or oil and wax systems does not need any time-consuming care or treatment. Parador natural oil is a "high solid product" based on natural raw materials made from plants. The factory treatment means that the oil penetrates the wood and the open-pored wood surface retains its natural, resistant texture. The oil systems used are surface ready, i.e. depending on the use/load, you do not need to apply additional maintenance oil after installation (see exception below for engineered wood Basic 11-5*), but can use it immediately after cleaning. Regular maintenance is necessary depending on the use/load and to retain the value of the product in the long term. Please also refer to the information in the chapter: Retaining value, cleaning and care - Maintaining lacquered finishes and natural oil/natural oil plus/oil-impregnated (UV oil) finishes, the productspecific instructions and the information from the associated technical data sheets (parador.de/en/services/downloads).

The benefit of the oil finish is basically that the matt, natural look emphasises the character of the wood. Unlike the UV oil finish, with natural oil and also natural oil plus engineered wood, small areas can be seamlessly renovated meaning that you can repair small damaged areas just where it is necessary. Compared with lacquered surfaces, however, it is easier for scratches or pressure points to damage the wood, although they are easier to remove or instead contribute to the wood's natural patina. Types of dirt or spilt liquids like coffee and red wine can be removed just as easily as with lacquered engineered wood. Please follow the cleaning and care instructions (see chapter Retaining value, cleaning and care).

* For products from the product range Basic 11-5 engineered wood, Parador recommends initial care for long-term maintenance of the original look (please use the profile care oils from the Parador product range).

Lacquered engineered wood

The Parador lacquer finish offers a very balanced protection of the wood with an elegant look at the same time. Optimum protection with high usability is achieved when, on the one hand, the lacquer is hard enough to ensure abrasion resistance and, on the other hand, is resilient enough not to crack under high loads. The Parador lacquer finish is perfectly balanced and guarantees a very high level of usability.

Assortment

The assortment says something about the visual appearance of the wood. With the Select, Natur, Classic, Living and Rustikal assortments, Parador offers the right choice for every taste. The Select assortment offers a rather calm, harmonious appearance, the Natur assortment a naturally balanced appearance, the Classic assortment a natural, earthy appearance, the Living assortment an earthy, lively appearance and the Rustikal assortment a distinctive, original appearance.

Hardness of the wood types

Hardness is the resistance that the wood offers to the penetration of a solid body under load. The hardness depends largely on the type of wood. The most common way of determining hardness is the Brinell method. The Brinell hardness HB in N/mm² is measured at a wood moisture content of 12 %. The higher the value, the harder the wood.

Wood type	Density g/cm ³	Brinell hardness N/mm ²	Hardness class
Maple	0.72	48	4
Beech	0.68	34	3
Oak	0.71	34	3
Ash	0.72	39	4
Cherry	0.58	30	2
Larch (also smoked)	0.60	19	2
Californian walnut	0.64	26	2
Thermo oak	0.60	31	3
Walnut	0.60	31	3

Wood varies in hardness depending on its individual growing conditions. These are therefore only approximate values.
Class 1: very soft wood - Class 2: soft wood - Class 3: hard wood - Class 4: very hard wood

Changes of shades from incidence of light

Daylight triggers chemical reactions in the wood substance that cause a change in colour. The change in colour only occurs on the surface of the wood. Most woods darken over time, but dark woods tend to lighten and light woods tend to turn yellowish. The overall look of the flooring becomes more uniform and balanced due to the colour change. Slight colour differences are thus automatically evened out in the long term.

Engineered wood and room climate

Wood is a hygroscopic material, i.e. it can absorb and release moisture. On the one hand, this can have a regulating effect on the room's climate, but it can also lead to the disadvantage that it swells (gets bigger) when it absorbs moisture or shrinks (gets smaller) when it emits moisture. Whether it swells or shrinks therefore depends directly on the indoor climate. If the climate is too warm and too dry, the wood shrinks; if it is too damp, it swells.

Multi-layer engineered wood also shrinks and swells, but to a significantly lesser extent than solid engineered wood. Particularly in the winter months, when the room humidity is often much too low (see illustration), the natural shrinkage of the material can lead to gaps forming. Conversely, when it is too damp, if the gap to the wall is not adequate or expansion joints are missing, the floor area may start to bulge upwards.

Note: Beech wood shrinks significantly more than most other common types of wood. This is why beech engineered wood can form comparatively wider joints in winter when the indoor climate is too dry.

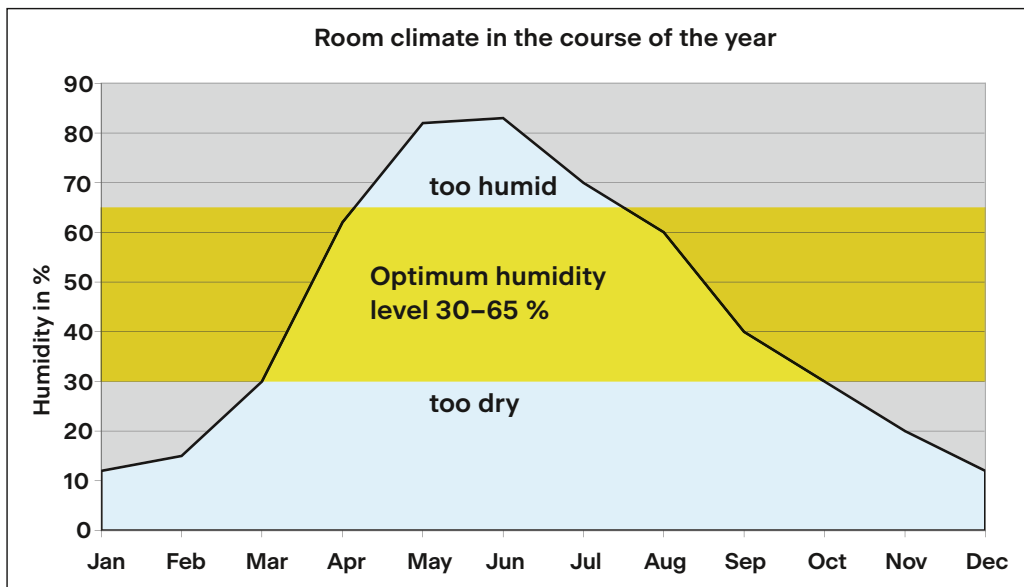

Product structure



①

Top layer

High-quality solid wood with a thickness of up to 4 mm is given a lacquer or natural oil finish. The lamella impregnation on the end edges and the all-round impregnated top layer prevent the penetration of moisture and provide additional protection against swelling. Gentle wood drying prevents cracking.

③

Balancing layer paper

Manufactured in a resource-friendly peeling process, the balancing layer paper made of solid spruce also supports the plank's dimensional stability.

②

Softwood middle layer

The solid wood core with vertical annual rings gives Parador engineered wood its excellent dimensional stability, even under the heaviest loads. The patented click mechanism milled into the wood ensures a long-term stable connection.

④

Click connection

The patented click connections from Parador guarantee simple, quick and uncomplicated installation with high pull-out resistance and a long-term firm connection for a permanently beautiful floor covering and a firm bond between the individual planks. As the planks are self-aligning, floating installation and whole-area gluing are possible without any problems. Once the floor has been installed, it is ready to walk on.

Tongue and groove connection (without illustration)

Tried and tested installation type with a classic connection for maximum installation options.

Technology



Swelling protection

All engineered wood flooring lines



Automatic-Click® system

Engineered wood Basic 11-5
 Engineered wood Classic 3025, 3060
 Engineered wood Trendtime 4, 6, 8
 Engineered wood Edition Harmonia



Allround-Click® system

Engineered wood Trendtime 3 (herringbone)
 Selected



Tongue and groove connection

Chevron

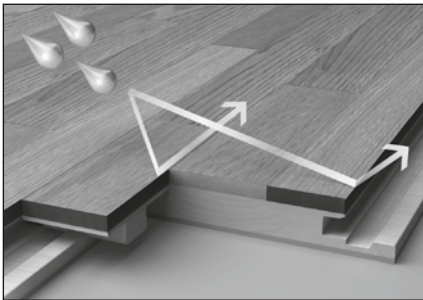

Excellent swelling protection

The lamella and all-round top layer impregnation ensure the best swelling protection. In addition, each individual strip is impregnated at the edges. For reliable protection against moisture, swelling and soiling.

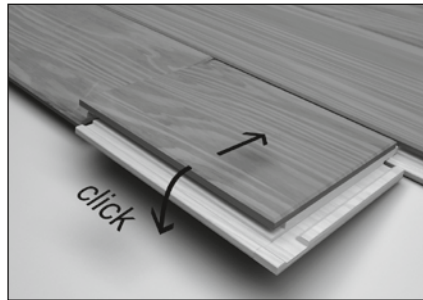

Patented click mechanism

The patented Automatic-Click® system with long and end edge locking makes installation quick, easy and possible without glue.

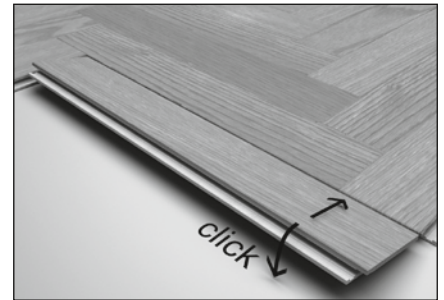

Innovative installation system for Trendtime 3 (herringbone) and Selected

The innovative Allround-Click® system without left or right-hand strips makes installation child's play.

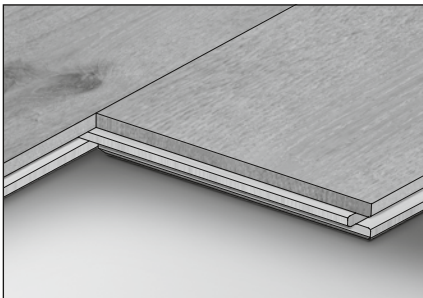

Classic tongue and groove connection

The all-round tongue and groove profile is characterised by maximum fitting accuracy and impresses with its ease of installation.

Accessories

Underlays

A suitable underlay must always be used between the sub-floor and the floating laminate flooring. Underlays reduce ambient noise and footfall sound, compensate for minor bumps and – depending on the finish – can provide the necessary moisture protection for mineral substrates. For all existing subfloors, which consist e.g. of dry floorboards or chipboard, only footfall sound insulation is used. A vapour barrier must not be used in these cases, otherwise mould may form in the underlay. A moisture barrier is mandatory with all mineral substrates (screed, concrete, tile), as otherwise moisture from the substrate may penetrate the flooring, which in turn may cause cupping or warping. An ambient noise and footfall sound protection or a combination product must also be used.

Comprehensive information about underlays can be found in our catalogues and online at www.parador.de/en.

Areas of application for Parador underlays
(PDF document)



Note:
Click on the text "PDF document",
on the QR code or scan the QR code

Parador offers the right underlays for every application.

Akustik-Protect 50

- › integrated vapour barrier

Akustik-Protect 80

- › without integrated moisture protection, e.g. for installation on wooden substrates

Akustik-Protect 100

- › integrated vapour barrier
- › good footfall sound and ambient noise insulation*
- › no additional moisture protection required (PE film)

* Impact noise is focused downwards, i.e. it is noticed in lower floors. Ambient noise is focused upwards and is noticed in the room in which it is created.

Akustik-Protect 50



Akustik-Protect 80



Akustik-Protect 100



Accessories

Akustik-Protect 500

- › integrated vapour barrier
- › even better characteristics than Akustik-Protect 50, 80 and 100
- › no additional moisture protection required (PE film)

PE film

When installing on mineral substrates without the use of underlays with moisture protection, additional moisture protection (PE film) is absolutely necessary.

Aluminium adhesive tape

- › for sealing the butt joints between the underlay strips for improved moisture protection

Adhesive SikaBond T54

- › Solvent-free adhesive for engineered wood

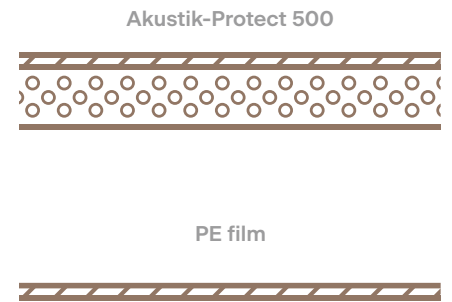

Accessories

Skirting boards

For a perfect finish, the Parador assortment includes the right decorative skirting board to match every floor design. It is attached to the wall with the Parador assembly adhesive or the special plastic clips with integrated cable conduit. End caps and transition caps, as well as external and internal corners round off the assortment.

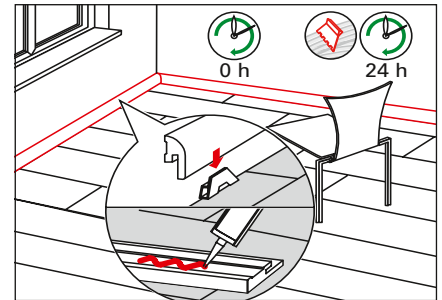

Skirting board assembly instructions

The floor covering is ready to walk on immediately after floating installation or only after the glue and adhesive have hardened (approx. 24 hours). Remove the plastic spacer wedges and attach the Parador skirting board using the patented clip technology or Parador assembly adhesive.

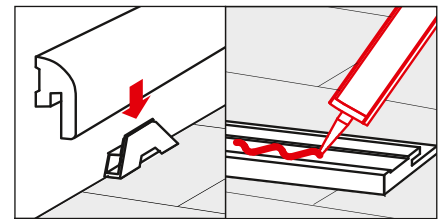

Assembly video - Fitting Parador skirtings



Note:

Click on the text "Assembly video", on the QR code or scan the QR code



Aluminium profiles

The Parador aluminium profiles are suitable for finishes, transitions, adjustments and stair edges. The basic profiles are screwed onto the subfloor or – in particular with an underfloor heating system – are glued to the subfloor. Attach cover profiles or screw down aluminium profiles – done.

Aluminium profiles are suited for use with floor coverings with a thickness of 8 to up to 18 mm.

Note: Please also pay attention to the application description on the product label.

Transition profile

Cover dimensions: 36 mm

The integrated slope adjustment enables a transition from floor coverings (carpet, tile, etc.) with a thickness of 5 to 20 mm.

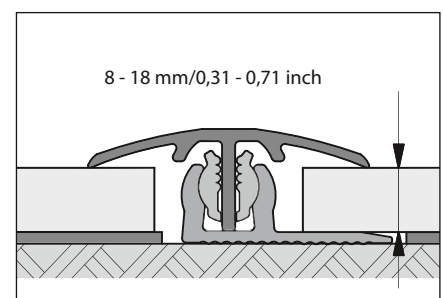

Accessories

Adapting profile

Cover dimensions: 45 mm

The integrated slope adjustment enables a transition from screed and / or floor coverings (carpet, tile, etc.) with a thickness of 0 to 20 mm.

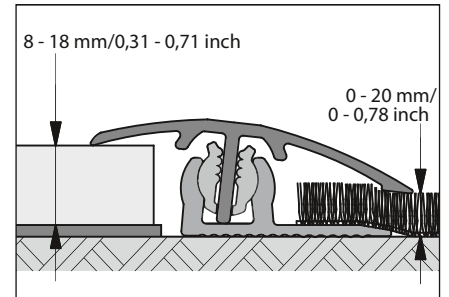

End profile

Cover dimensions: 26 mm

Note: For floor coverings with a thickness of 8 to 18 mm.

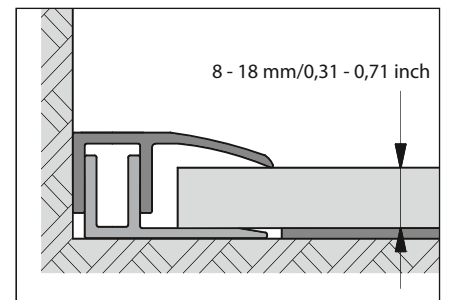

Stair edge profile

Cover dimensions: 28 mm and 23 mm to the step

Note: For floor coverings with a thickness of 8 to 18 mm.

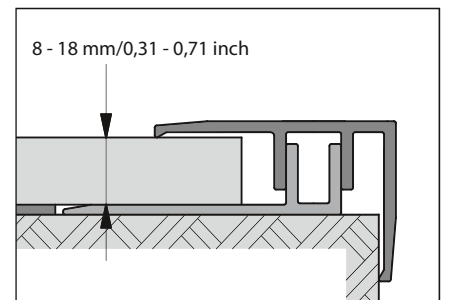

Tool

You will need the following tools and aids to install Parador engineered wood and to use Parador accessory products:

Tape measure or folding ruler, cutter knife, pencil, handsaw, Parador plastic spacer wedges, Parador MultiTool, hammer, drill and jigsaw, crosscut saw, or circular saw, and possibly glue and adhesive spatula for whole-area gluing.

Other tools and materials may be required, depending on the application: "Gun" for assembly adhesive, metal saw for aluminium profiles; Parador glue D3.

Note: For a perfect result of your installed floor down to the last detail, you will need covers, e.g. to cover movement joints around radiator pipes routed through the floor. Specialist retailers offer many products for every application.

Installation at a glance

Engineered wood can be installed in two ways: by whole-area gluing to the subfloor or by a floating installation. Engineered wood glued over the whole area is comparatively quiet, as vibrations and hollow spaces can be largely excluded. Thanks to the simple Automatic-Click® system, laying Parador engineered wood as a floating installation can be carried out quickly and easily without prior knowledge – and is therefore the most popular installation method.



Lay out the underlay on the prepared subfloor.



Centre/angle the installation area and adjust the first row of planks by cutting it to size.



Use the plastic spacers to maintain a clearance of at least 10 to 15 mm from all walls and fixed objects in the room.



The last plank of the first row is shortened to the required length, taking into account the wall clearance. The cut-off piece of the plank is used as the start of the second row.



Start the next row from the left again. Simply click the planks together lengthways. Gluing the planks is not necessary.



Join the end joints using a hammer and protective block. The long and end joints will connect automatically. Continue this installation process throughout the room.



Use a leftover piece or the Parador MultiTool to transfer the wall outline to the last row of planks.



Cover edge joints using matching skirting boards from the extensive Parador product range.

Detailed installation information is available starting on page 14.

The installation of engineered wood Trendtime 3 (herringbone), Selected deviates from this. Detailed installation instructions can be found from page 26 onwards. Before installation, please observe the installation rules listed on the following pages. Compliance with these instructions is a requirement for successful installation and helps guarantee that you can enjoy your new engineered wood for a long time.

Installation rules

These installation rules and the assembly process shown below are generally applicable. Other special or different rules and instructions, which are advisable and mandatory, may be shown on the pack leaflets inserted with the relevant products.

Installation video – Installing Parador engineered wood correctly (incl. surface treatment oils)



Note:

Click on the text "Installation video", on the QR code or scan the QR code



1. Inspect planks for material defects

Before and during installation, the engineered wood planks should be checked thoroughly for material defects (e.g. due to improper transport) (Figure 1). Planks with visible defects or damage must not be installed. Assembly should only take place under daylight or with adequate lighting, as otherwise any damage or faulty planks cannot be detected in some circumstances.

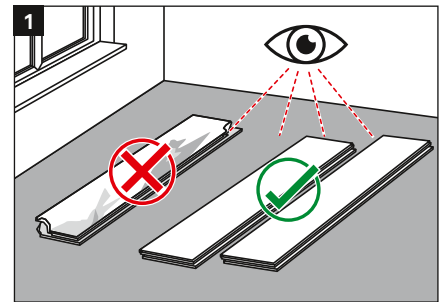

2. Acclimatisation before installation

The engineered wood planks must be acclimatised over a period of at least 48 hours at a room temperature of 17 - 24 °C and a relative humidity of 30 - 65 % in the room where they are being installed (Figure 2). That means that the sealed packages must adjust to the climate conditions in the room. If there are major climate differences between the storage area and the room of installation, the acclimatisation period should be longer preferably. If the climate conditions are almost the same, the period can also be shorter. Please store the packages on an even base without opening them. It is essential that you comply with these points, especially in new builds where the humidity is usually very high.

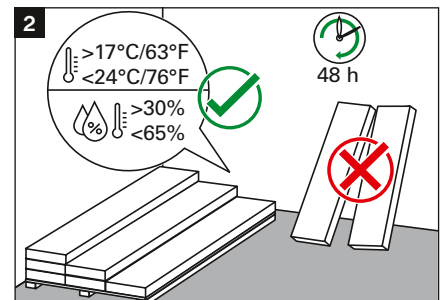

Installation rules

3. Installation in wet rooms

No installation in permanently damp rooms/wet rooms

Engineered wood must not be installed in areas where water is likely to lodge on the floor (Figure 3). Standing water penetrates the wood and can damage it permanently. In permanently damp areas or damp environments (sauna areas, small bathrooms etc.), engineered wood should not be installed, as the risk of moisture penetrating cannot be ruled out. If engineered wood is expected to be installed in larger bathrooms (recommendation: engineered wood with natural oil or natural oil plus surface and whole-area gluing), care must be taken that it is not installed in close proximity to areas where water might lodge (shower, bathtub, toilet, sink) and that the relative humidity of the room is kept within the recommended range of 30 -65 %. The formation of puddles and the effects of damp must be prevented at all costs at the edges and in the joint areas, including expansion joints, and on the area as a whole (Figure 4). Water penetrating underneath the flooring may for example cause the formation of mould.

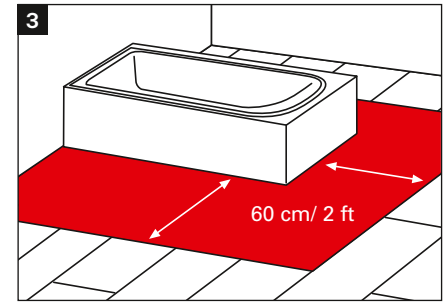

4. Subfloor condition

All existing subfloors must be level (max. 3 mm over a length of 1 metre), dry and sufficiently firm. Larger bumps are levelled out with standard filler. The surface of the subfloor should be free of cracks, breaks or gaps. Loose subfloors or insufficiently firm subfloors (PVC/carpet coverings) must be removed. Mineral substrates/screeds must be sufficiently dry. Please refer to the instructions in the chapter on substrates.

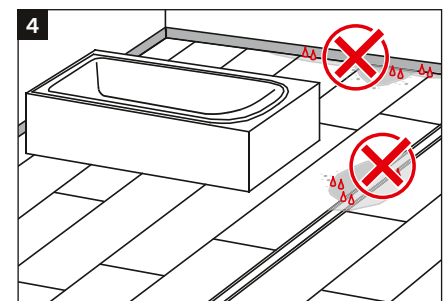

5. Vapour barrier for mineral substrates

With dry, mineral substrates, as a precautionary measure a 0.2-mm-thick PE film or alternatively a Parador underlay with integrated moisture protection must be placed underneath. This prevents any residual moisture from reaching the back of the engineered wood. The polyethylene film only acts as a vapour barrier and should be installed and glued with an overlap of approx. 30 cm along the edges of the sheets. Under no circumstances does a polythene film act as a building sealant! See also the chapter on underlays.

Installation rules

6. Maintain expansion joints/wall clearance

As already described at the beginning, the natural material wood shrinks or swells depending on the climatic conditions. The installed engineered wood therefore needs to be kept a suitable distance away from all fixed components, in other words walls, supports, radiators etc., which is known as the wall clearance or expansion joint. Expansion joints are also required if a defined installation area is exceeded (see installation rule 7). Insufficient wall clearance is the most common installation error. This often only becomes noticeable in summer, as the increased humidity and temperature in the summer months inevitably makes the engineered wood expand.

The expansion joint or wall clearance should be at least 10-15 mm on each side, more on larger areas.

The rule of thumb is:

per metre of flooring keep at least a 2 mm expansion joint at both sides of the room. (Example: room 5 m wide = at least 10 mm edge joint on each side).

Even if the installed material only abuts a single point in the room, the floating material may start to push up and warp. “Popular” weak points in this case are door frames, joints to stairs, radiators and end rails. Heavy objects (over 350 kg), such as kitchen units and cupboards (the flooring can move on one side only), require twice the wall clearance on the opposite side. We recommend setting up heavy objects and fitted furniture (kitchens, fitted units, aquariums etc.) before installation and only installing the floor just underneath the plinth. This makes it easy to take the flooring back up at any time. The expansion joints are covered by skirting boards at the walls and in other areas by special flooring profiles. A permanently elastic joint sealing compound can also be used in the area of steel frames. Construction expansion joints must always be adopted in the engineered wood surface when gluing the whole area. Joints in the screed, so-called furrows, do not have to be adopted if the joint is glued (e.g. with epoxy resin). It may be advisable to include the position of heavy objects at the installation planning stage of an area of engineered wood laid as a floating installation (tip: avoid open joints by gluing the ends in the stress areas).

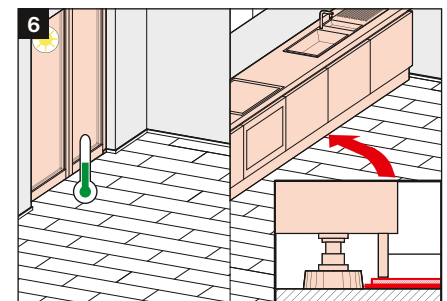
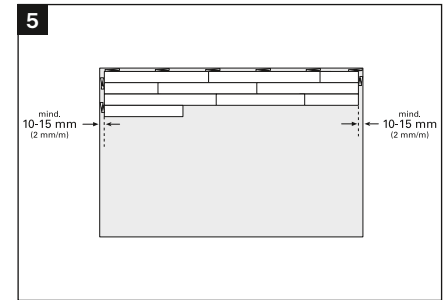

Installation rules

7. Layout of expansion joints

As the engineered wood will swell or shrink as just described depending on climate conditions, further expansion and movement joints of at least 10 mm are necessary under the following circumstances:

- › larger areas (over 8 × 12 m)
- › irregular shaped areas
- › installation from room to room

These movement joints are covered with corresponding transition profiles.

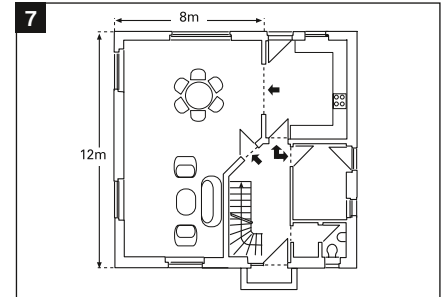

Note: The installer is always liable if expansion or movement joints are omitted.

8. Pattern and offset installation

Engineered wood elements can either be installed in a regular or random fashion. In any case, it must be ensured that the overlap or minimum offset of the head joints is > 40 cm.

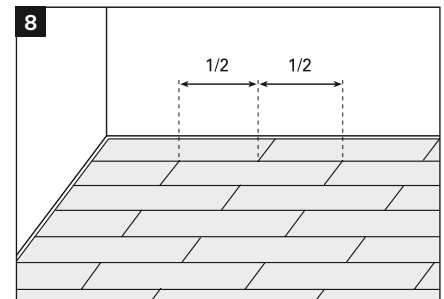

9. Installation direction/incidence of light

For optical reasons, the long side should be laid parallel to the incidence of light, i.e. the long side runs in the same direction as the light entering the room. If there is more than one window, please go by the largest window. If the floor plan of the room is very unusual, the direction of installation should also be judged according to how the room is divided (see installation rule 10).

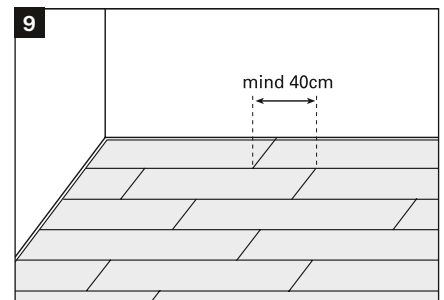

10. Installation direction/room floor plan

Also for optical reasons, the long sides of the flooring should be at right angles to the long side of the room. This makes the room appear more squarer and bigger instead of long and “tube-like”.

Note: Installation should take place from the brighter areas of the room to the darker ones (e.g. from the window into the room).

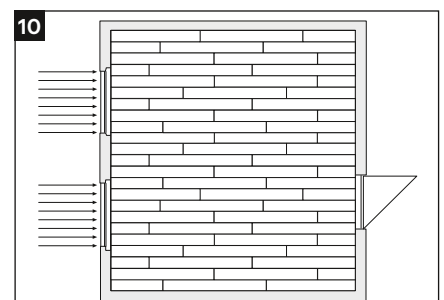

Installation rules

11. Installation from multiple packages

Engineered wood is a natural product that underpins its unique character in colour and texture, etc. These characteristics of nature are always different. For this reason, care must always be taken during installation to ensure that the planks are mixed from several packages in order to maintain a balanced appearance.

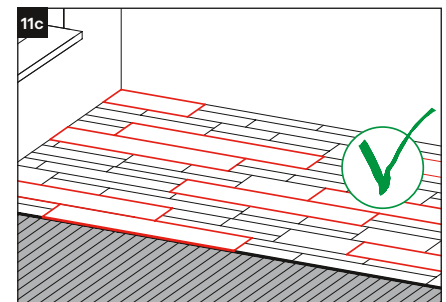
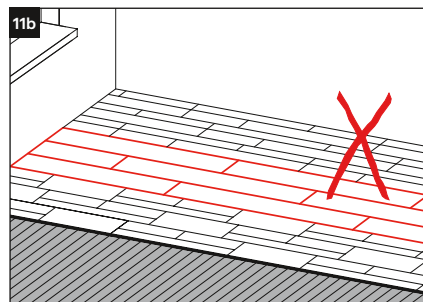
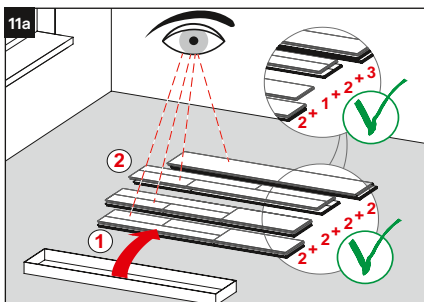
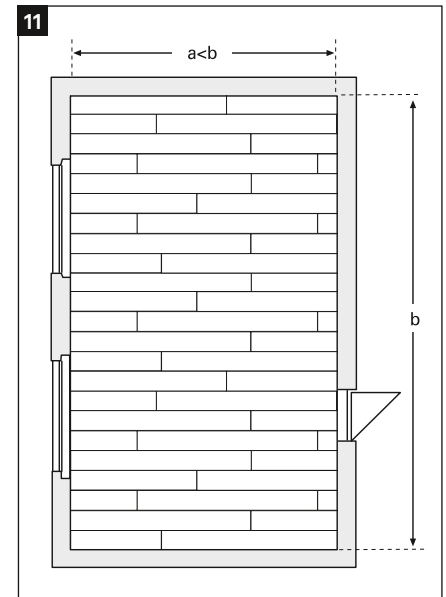

Subfloor requirements

- › The basic requirement for the installation of engineered wood is a firm, clean, dry and even subfloor.
- › Uneven areas of more than 3 mm across 1 m should be evened out with a suitable filler (Figure 1).
- › When installing on old wooden floorboards and particle boards, loose boards must be screwed to the substructure to reduce any creaking. The flooring should be laid at right angles to the lengthways direction of the wood planks.
- › For reasons of strength and from a hygienic point of view, carpets are not suitable as a subfloor and must be removed (Figure 2).
- › We only recommend an installation on existing PVC, CV or linoleum coverings if the flooring is glued in place, has no loose areas and there is no underfloor heating.
- › Screeds must not exceed the following moisture level :

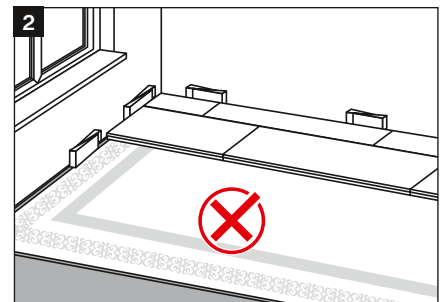
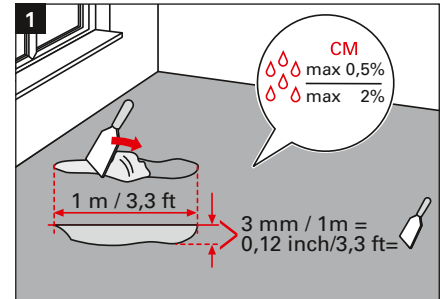

	Anhydrite screed	Cement screed
without underfloor heating	max. 0.5 CM %	max. 2.0 CM %
with underfloor heating	max. 0.3 CM %	max. 1.8 CM %

Generally speaking, the screed moisture must be checked using a suitable test measuring device. A test sample must be taken from the bottom third of the screed composition, whereby the thickness of the screed must be measured and documented at each test point. The figures only apply to screeds without additives. For screeds with additives, or quick-drying screeds, the figures specified by the manufacturer should be observed.

With mineral substrates*, as a precautionary measure a 0.2 mm thick PE film must be placed underneath as a vapour barrier (allow strips to overlap by at least 30 cm, apply adhesive tape, leave a trough-shaped overhang at the edge and cut off the excess with a knife after attaching the skirting board). Or you can use Parador underlays with footfall sound insulation and integrated moisture protection. If moisture keeps on rising from the subfloor, please seal the floor area with a suitable liquid sealer.

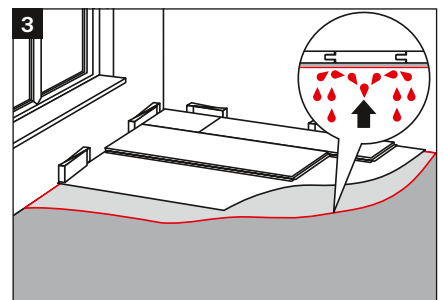

* Mineral substrates include, for example, concrete, screed and stone.

Installation options

1. Floating installation

If the engineered wood is installed without a fixed connection to the subfloor i.e. only the planks are joined to one another, we call this a “floating installation”. The flooring can then move or float freely on the underlay. Thanks to the simple click technology, Parador engineered wood – with the exception of Trendtime 3 herringbone – can be installed in this way with ease and without prior knowledge.

2. Whole-area gluing

Whole-area gluing is another installation option. Here, the entire engineered wood floor is glued to the screed using special adhesives. This installation is permanent, i.e. dismantling is very time-consuming. However, one advantage of this option is that noise is reduced significantly, meaning that the floor is quieter to walk on. For products with the Automatic-Click® or the Allround-Click® connection, installation in the bed of adhesive is not a problem. The planks do not have to be moved in the adhesive bed as is the case with other click connections. This guarantees an easier, neater and faster installation process than with conventional engineered wood. Please also refer to the “Checklist for whole-area gluing of Parador engineered wood” in the appendix. Please always glue the following engineered wood floors over the whole area: Trendtime 3 Herringbone.

3. Installation on underfloor heating

Parador engineered wood is suitable for both floating and completely glued installation on hot water underfloor heating systems. The favourable heat transmission resistance allows underfloor heating to be run economically. On the technical data sheets you will find further information, for example about the heat transmission resistances of our engineered wood floors. When it comes to installation/application, please also bear in mind the “Checklist for installation on hot water underfloor heating” in the appendix. The maximum surface temperature of 29 °C must not be exceeded and a very fast heating process must be avoided. The Parador underlay Akustik-Protect 50, 80, 100 or 500 should always be used as an underlay for floating installations.

Note: The wood types beech and maple react sensitively to moisture and temperature fluctuations. The formation of gaps can therefore not be ruled out.

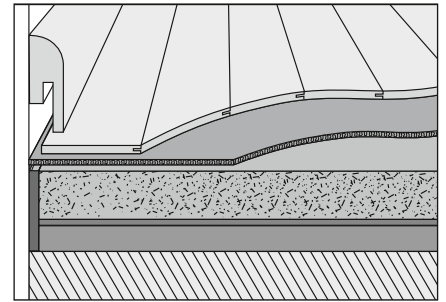

Engineered wood on Akustik-Protect 100 underlay / mineral screed

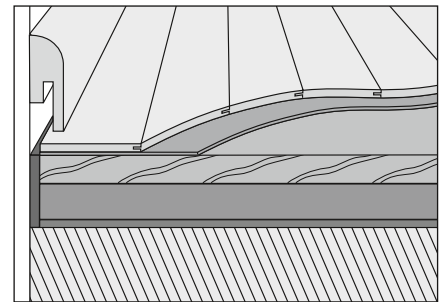

Engineered wood on Akustik-Protect 80 underlay / floorboards

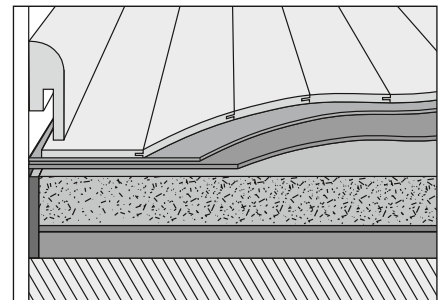

Engineered wood on Akustik-Protect underlay / PVC / mineral screed

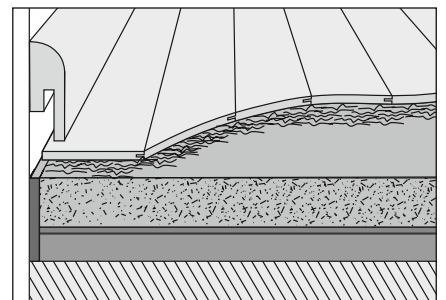

Engineered wood glued over the whole area

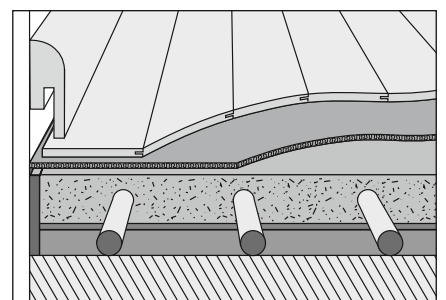

Engineered wood on Akustik-Protect underlay with hot water underfloor heating system

Installation options

Please note the following for installation on electric underfloor heating systems:

- › installation only with systems that have temperature sensors and controllers
- › no installation on older design electric underfloor heating systems (installed before 2000)
- › no installation on night storage heaters.

4. Use of floor cooling

According to prevalent expert opinions, cooling a room by maximum 5 °C is easily possible at a maximum relative humidity of 65 %. (According to the workplace directive, the lower floor temperature limit of 19 °C should also be maintained in “normal” housing. People are more prone to ill health in areas with cold floors). The Parador floor coverings can be used without restrictions if these specified conditions are complied with (whilst bearing in mind the main Parador installation and fitting instructions). When installing on underfloor heating or cooling systems, it is essential to seek approval from the system manufacturer. The specified parameters for installation on such systems must be complied with. Installation on heating systems with a night storage function is out of the question.

Note: Please note the influence of any underlay used on the underfloor heating or floor cooling system.

Assembly

Engineered wood Basic 11-5; Engineered wood Classic 3025, 3060; Engineered wood Trendtime 4, 6, 8 and Engineered wood Edition Harmonia with Automatic-Click® system

Installation video – Engineered wood



Note:
Click on the text "Assembly video",
on the QR code or scan the QR code

Preparation

Once you have taken note of the installation rules and the underlay is installed, it is possible to start with the actual installation of the engineered wood. In order to achieve an even appearance of the first and last row, measure the width of the room at right angles to the direction of installation and work out the width of the planks. Install elements mixed from several packages so that you get an even appearance across the area. The last element of each row is cut to length and the leftover piece, which should not be shorter than 15 cm, is used to start the next row. The cross joints should be offset from row to row by at least 40 cm ("random bond"). Please check each plank for defects before installation and only lay planks that are in perfect condition.

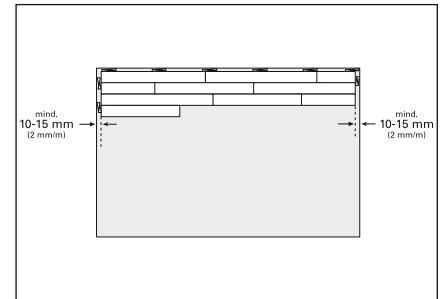

As a prerequisite for the longevity of your flooring, please note the following points:

- › Maintain a comfortable climate of 40-65% (use humidifiers, especially in the winter months, with existing fireplaces and floor-to-ceiling windows with sunlight and conservatories).
- › Store the packages in closed rooms with a climate suitable for the product. Please install the products from opened packages immediately. Seal packages that have been opened airtight.

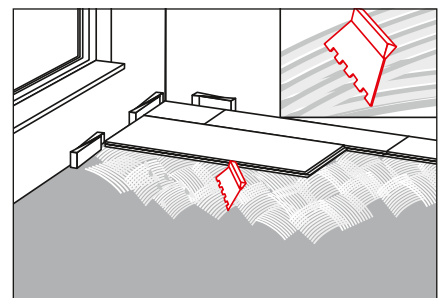
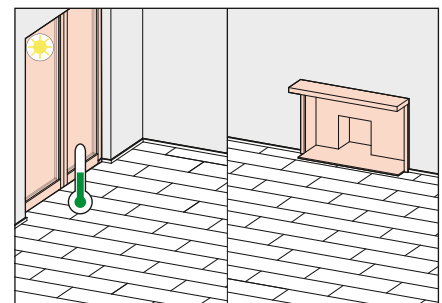

Assembly

Engineered wood Basic 11-5; Engineered wood Classic 3025, 3060; Engineered wood Trendtime 4, 6, 8 and Engineered wood Edition Harmonia with Automatic-Click® system

Assembly

Figure 1: First remove the long tongue on the complete first row of planks using a saw, unless you have to cut the first row to size anyway. Start the first row in a left-hand corner of the room and place the cut-off long side against the wall. The required wall clearance of 10-15 mm is achieved with the Parador plastic spacer wedges. If the wall is not straight, align the first row to make it straight and lock the end joints together, see page 24, Figure 10.

Figure 2 and 3: Start on the left with the first plank of the second row and click it lengthways into the first row. To do this, guide the tongue side of the plank into the groove of the previous row at an angle of approx. 25° and then lower the plank. The plank clicks in when lowered, resulting in a tight fit with no play.

Figure 4: The following plank, like all the rest, is then clicked in place in the same way on the long side and pushed tight to the head end of the previous plank. The solid top layers must abut!

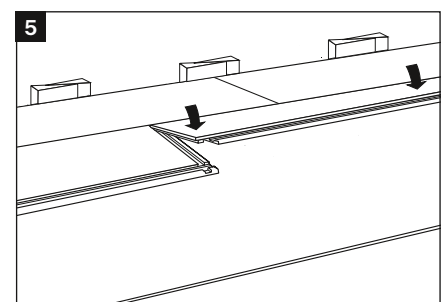
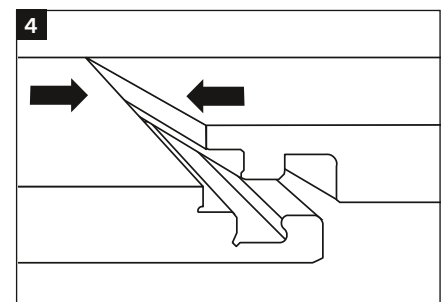
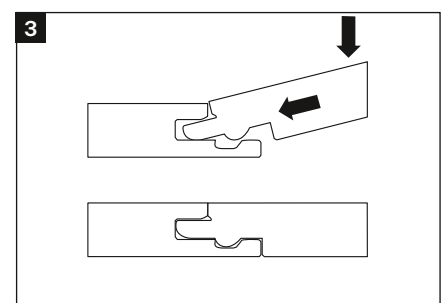
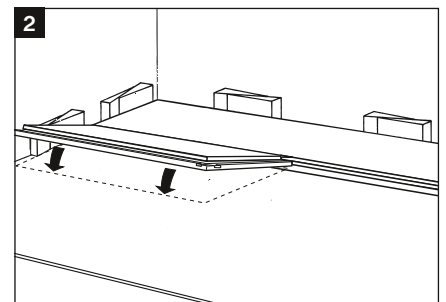
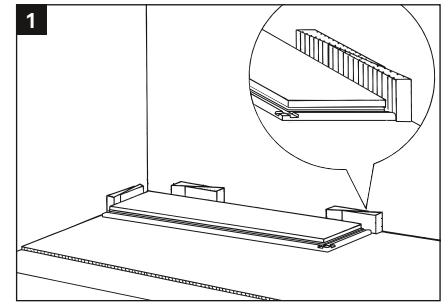

Assembly

Engineered wood Basic 11-5; Engineered wood Classic 3025, 3060; Engineered wood Trendtime 4, 6, 8 and Engineered wood Edition Harmonia with Automatic-Click® system

Figure 5 (p. 23), 6 and 7: Next, the longitudinal joint along the entire plank must be locked from left to right by simply pressing it in place and pushing it down. Before locking the end joint, it is important that the whole plank is closed along the longitudinal joint. Then lock the end joint by joining the planks together with a hammer and protective block. Make sure that the ends are tightly together, otherwise it is not possible to lock them. Install all other planks accordingly.

Figure 8: To dismantle, lift the entire row of planks and pull it out of the previous row at an angle. The end joints are then levered apart, starting with the last plank section installed. The locking mechanism thereby remains intact and the planks can be reused. Caution: Avoid tilting the planks, as this can damage the locking mechanism.

Figure 9: Measure end piece using a square (to do this, place the plank with the groove side facing the previous row) and saw it off. Do not forget the wall clearance! When using a jigsaw, place the top side of the plank facing down. When using a table saw, place the top side of the plank facing up.

Figure 10: Measure the last row using the MultiTool or a left-over piece of plank. Remember to maintain a wall clearance of 10-15 mm.

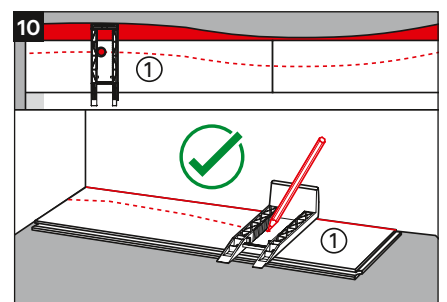
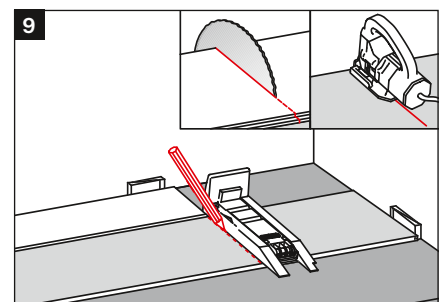
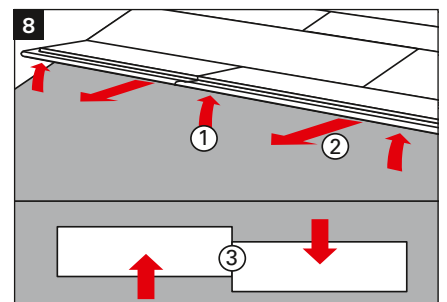
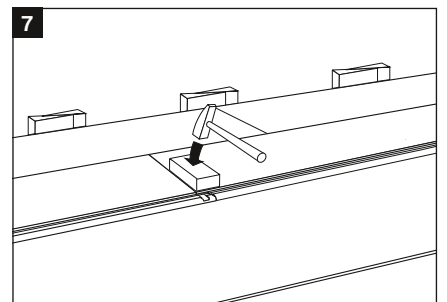
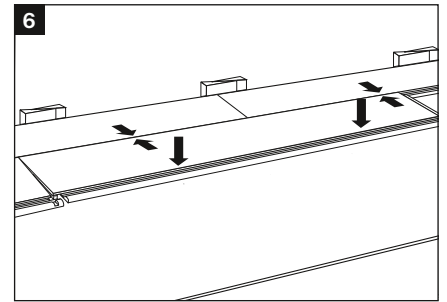

Assembly

Engineered wood Basic 11-5; Engineered wood Classic 3025, 3060; Engineered wood Trendtime 4, 6, 8 and Engineered wood Edition Harmonia with Automatic-Click® system

Figure 11: With the exception of whole-area gluing, the flooring is ready to walk on immediately after installation. All you have to do is remove the Parador plastic spacer wedges and attach the Parador skirting board using the clip technology or Parador assembly adhesive.

Figure 12: Wall not straight: Align the first row to make it straight and follow the contour of the wall. To do this, use the Parador MultiTool (as described in the graphic) to mark the corresponding width on the plank and then cut the plank along the mark.

Figure 13: Shortening a door frame: lay a leftover piece of plank (on the relevant underlay) against the frame and cut the frame along the plank.

Figure 14: How to make pipe holes: make the diameter of the pipe holes 20 mm bigger than the pipe is. Mark the holes, drill out and saw off at an angle of 45° as shown in the illustration. Glue the sawn out piece in place. Do not forget the wall clearance here either.

Figure 15: Installation in places that are difficult to access: If you cannot insert the planks at an angle and click them together, it is advisable to remove the snap-in tongue on the bottom of the tongue and glue the planks together. Apply glue to the lower groove side and push the planks flat into each other (standard tongue and groove principle).

Figure 16 and 17: Gluing information: If underlay requirements for the country-specific standard with regard to evenness (3 mm/1 m) or relative humidity (30-65%) are outside the tolerance for the specific engineered wood, gluing (see Figure 16) is recommended. The same applies to the head side (Figure 17) if using on an underfloor heating system.

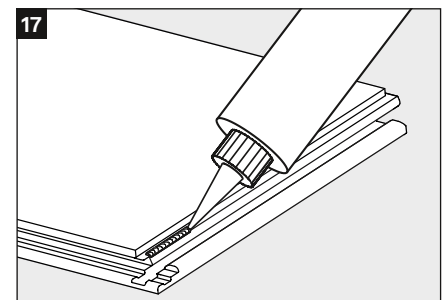
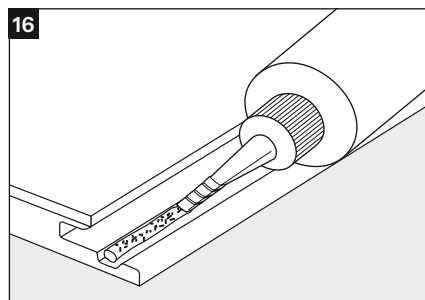
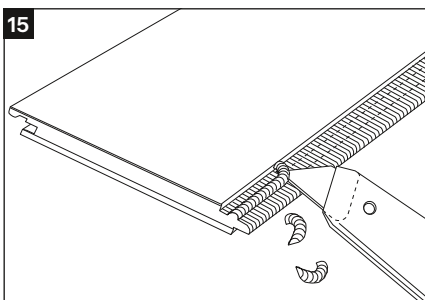
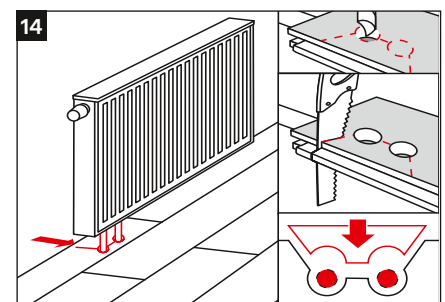
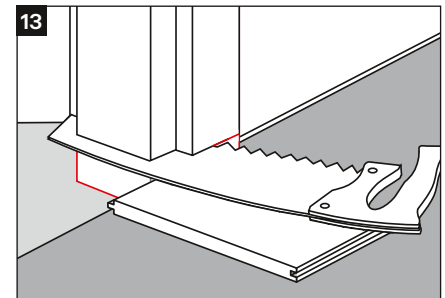
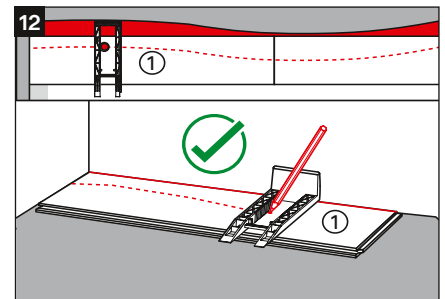
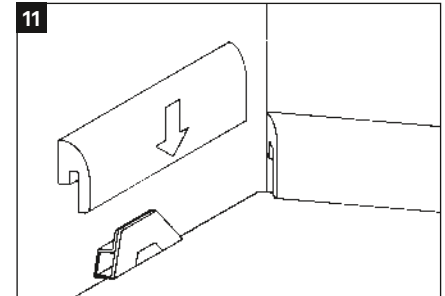

Assembly

Engineered wood Trendtime 3 (herringbone) and Selected glued over the whole area with Allround-Click® system

Installation video - Engineered wood Trendtime 3 (herringbone) and Selected (herringbone) glued with Allround-Click® system



Note:

Click on the text "Installation video", on the QR code or scan the QR code



Figure 1: As a “floating installation” may result in settling noises, Trendtime 3 (herringbone) and Selected must always be glued over the whole area to the subfloor (concrete, screed, etc.).

In this regard please also read page 41, chapter: Checklist for whole-area gluing of Parador engineered wood.

Please follow the instructions of the adhesive manufacturer.

Preparation

Once you have taken note of the installation rules and the underlay is ready, it is possible to start with the actual installation process.

Figure 2: When installing strips (herringbone), the appearance of the room depends very much on the installation method. With the 0° direction, installation is parallel to the room walls.

Figure 3: If a herringbone pattern is installed diagonally across the room, this is the so-called 45° direction.

Figure 4: For the installation of herringbone patterns, all you need are the “universal” planks developed by Parador, in other words no left and right-hand planks. The installations shown above can be made with this plank, the installation direction is not specified. You can start in a corner of the room (preferably by rows (Figure 4, left-hand side) or in the centre of the room (preferably braid by braid) (Figure 4, right-hand side).

Figure 5: With the recommended installation direction, it must be ensured that the planks are installed so that the groove side of the planks is in the direction of installation and the tongue is therefore clicked into the groove. If, specifically with wholearea gluing, the groove is clicked into the tongue during installation, the planks or set of planks already installed may lift.

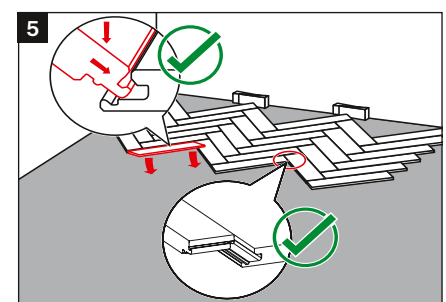
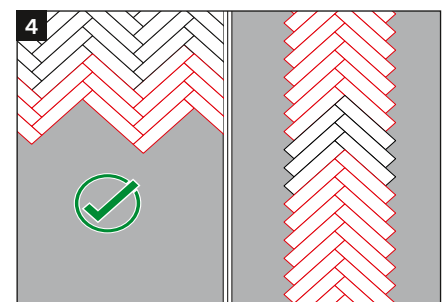
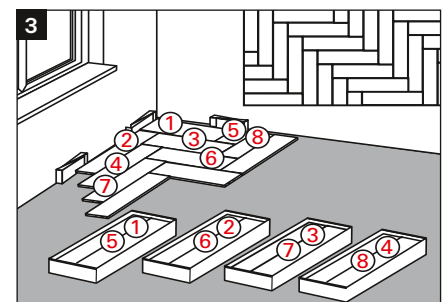
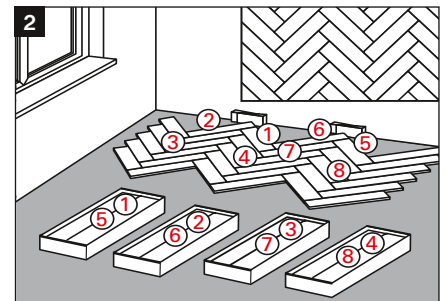
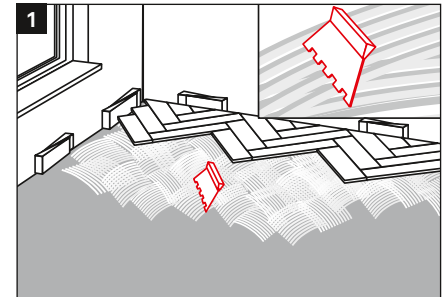

Assembly

Engineered wood Trendtime 3 (herringbone) and Selected glued over the whole area with Allround-Click® system

Note: Please observe the processing instructions as well as application and curing times of the engineered wood adhesive. Please mix engineered wood planks from different packages (Figure 2 and 3). This prevents similar cover layers being placed next to each other (e.g. grain structure) and achieves a balanced appearance.

Figure 6: Please check each plank for defects before installation and only lay planks that are in perfect condition.

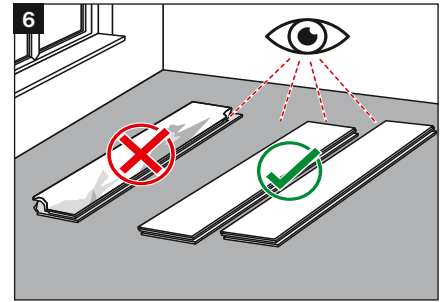

Figure 7: To determine the main orientation, it is necessary to work out the centre of the opposite wall. After staggering this spot parallel by 3.5 cm, the axis lies exactly over the ends of the installed braid as shown. If necessary, this axis must be fixed in place with a piece of string. The edge planks must be adjusted. Saw cut at 45° or according to the contours of the wall. Please bear in mind a gap to the wall of 8-10 mm. This gap required all the way round must also be maintained for fixed installations.

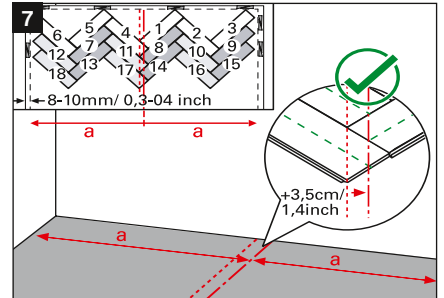

Figure 8: The triangular open spaces must be filled with suitably cut planks. The long and end edge areas, which are not held independently due to their shape, must be weighed down until the adhesive has cured in order to prevent protrusions (incorrect adhesions).

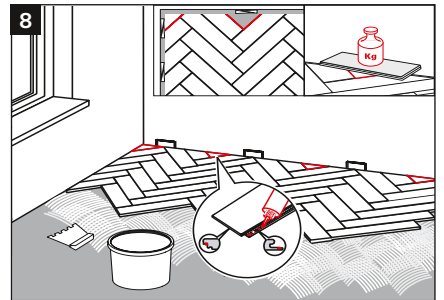

Figure 9: Once the adhesive has cured (approx. 24 hours), the flooring is ready to walk on. All you have to do is remove the Parador plastic spacer wedges and attach the Parador skirting board using the clip technology or the Parador assembly adhesive.

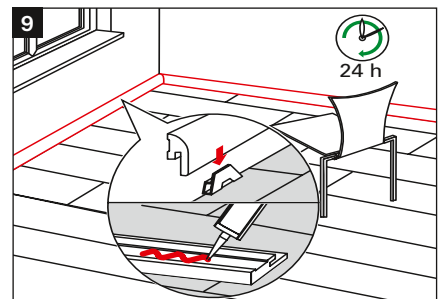

Figure 10: Shortening a door frame: lay a leftover piece of plank against the frame and cut the frame along the plank. When doing so, place the leftover piece of plank on an underlay with a height of approx. 2 mm to imitate the height of the adhesive.

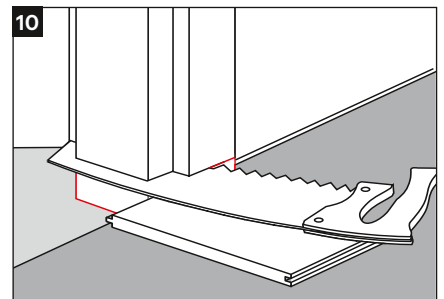
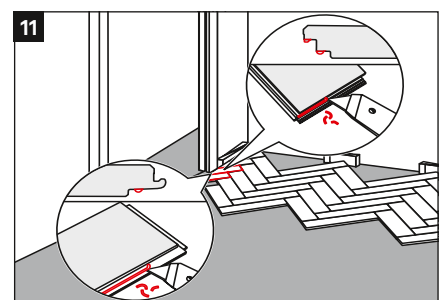

Figure 11: In the areas in which the planks can no longer be swivelled into place (door frames, radiator pipes, etc.), they must be inserted horizontally. For this, the snap-in tongues must be removed using a knife.



Assembly

Chevron engineered wood glued over the whole area with tongue and groove connection

Figure 1: Installing chevron strips in different installation patterns requires a high degree of precision and craftsmanship. We therefore recommend having the chevron strips installed by a trained specialist. The process of installing chevron engineered wood is complicated.

Figure 2: Always glue the chevron strips to the subfloor (concrete, screed, etc.) over the whole area, as a “floating installation” may result in settling noises. In this regard please also read page 33, chapter: Checklist for whole area gluing of Parador engineered wood.

Note: Please follow the instructions of the adhesive manufacturer, in particular the processing instructions and the application and curing times of the engineered wood adhesive. We recommend a solvent-free adhesive for engineered wood and solid wood.

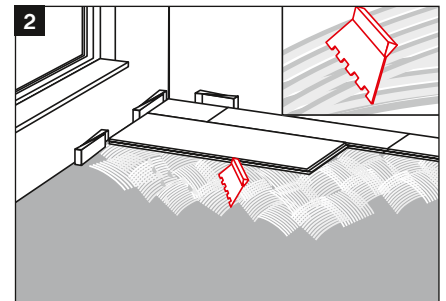
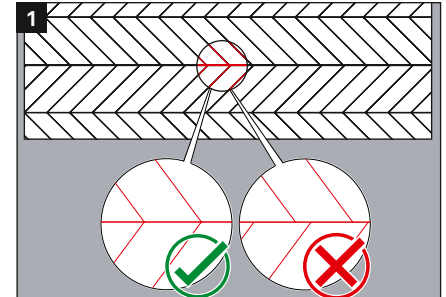

Preparation

Once you have taken note of the installation rules and the underlay is ready, it is possible to start with the actual installation process. The chevron strips feature a tongue and groove connection. This allows you to create many other installation patterns in addition to the classic French herringbone installation, which is described step by step below. When it comes to the many different installation options, different quantities of chevron strips are required in the left-right distribution.

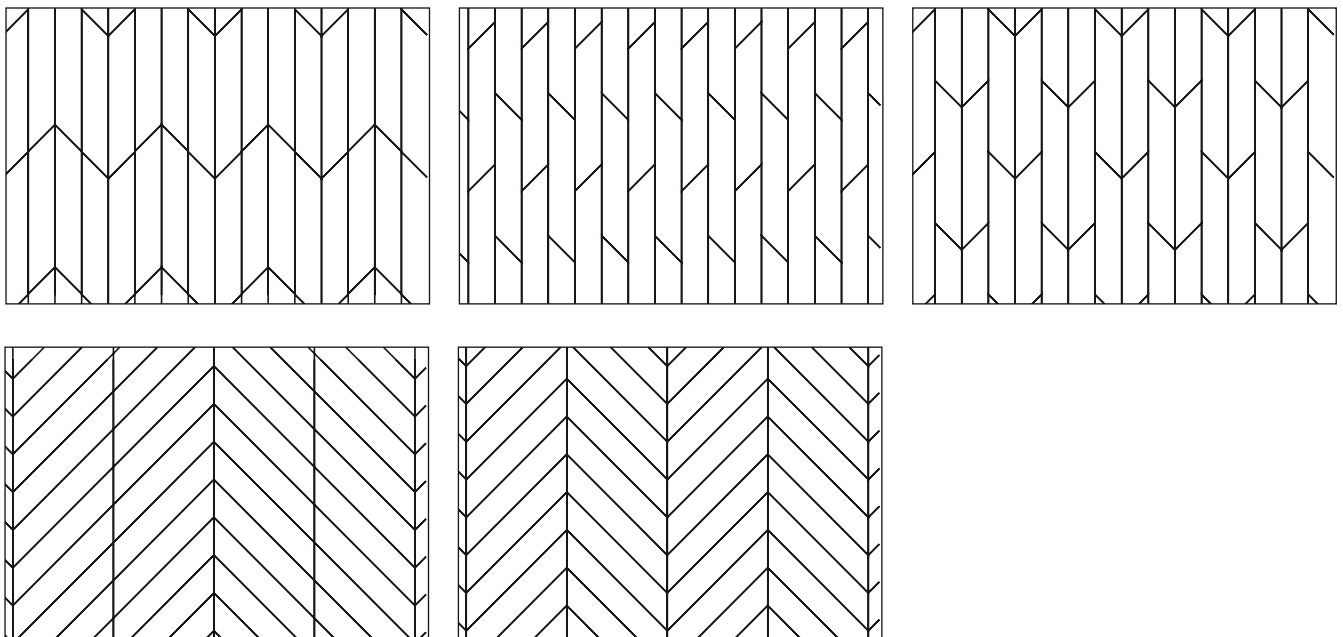

Assembly

Chevron engineered wood glued over the whole area with tongue and groove connection

Figure 3: When installing the classic French herringbone pattern with chevron strips, the appearance of the room depends very much on the installation method. With the 0° direction, installation is parallel to the room walls. With the 45° direction, the installation runs diagonally in the room. You will need left and right-hand chevron strips to install the classic herringbone pattern.

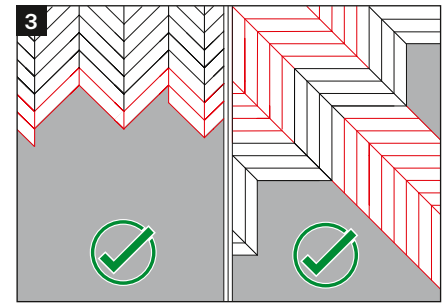

Figure 4: Connect the chevron strips to each other by moving them horizontally. This is made possible by the classic tongue and groove connection of the chevron strips.

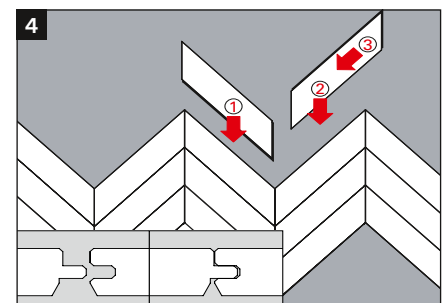

Figure 5: Please check each strip for faults before installation. Only install chevron strips that are in perfect condition.

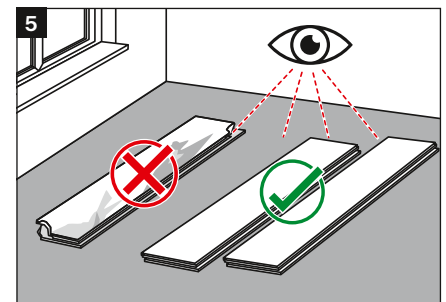

Figure 6: To determine the main orientation of the braid, establish the centre between the opposite walls. As a result, the axis lies exactly over the ends of the braid as shown. If necessary, fix this axis with a chalk line or a piece of string. You then place the strips precisely along this line. Unstraight wall or offsets in the walls must also be taken into account.

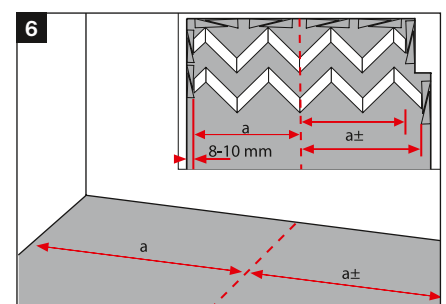
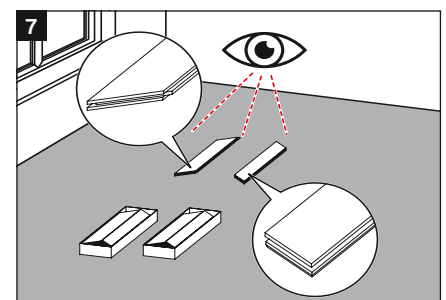

Figure 7: First sort the strips into left and right-hand strips. You should mix the strips from different packages. This ensures an even appearance of the installed area.



Assembly

Chevron engineered wood glued over the whole area with tongue and groove connection

Figure 8: Form a group of 5 to 16 strips with a maximum length of 2 metres. To do this, use a strip that you lay cross-ways to the group. This serves as a stop and alignment aid. Then join the strips of the first strand with white glue.

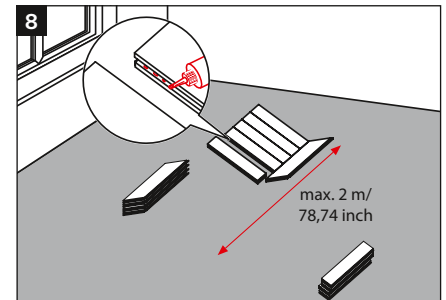

Figure 9: Place the connected strand on the centre line in the room and draw the strand on the floor with a pencil.

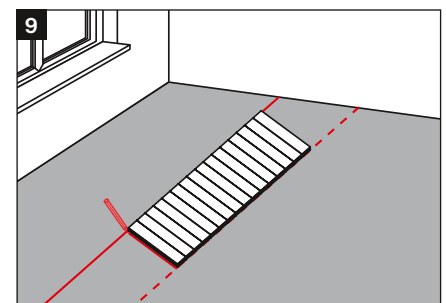
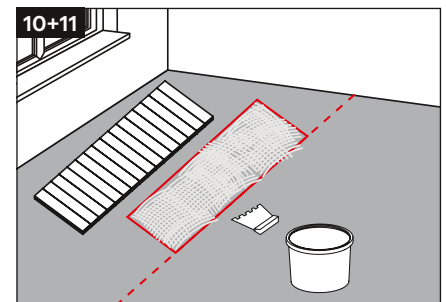

Figure 10 and Figure 11: Apply the adhesive only in the marked area using a B11 spatula. Then pull the connected strand onto the gluing surface and align it very precisely. Then weight down the area. After approx. 2 hours, the strand in the adhesive bed can be filled over the entire length of the room.



Note: When working with the adhesive, please ensure that it is applied over the entire area. This is the only way to ensure adhesion over the whole area.

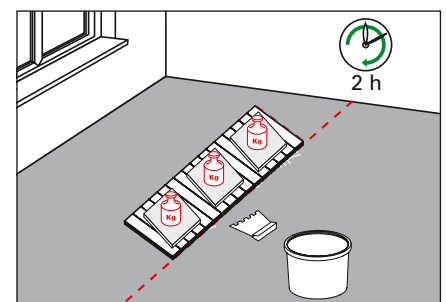
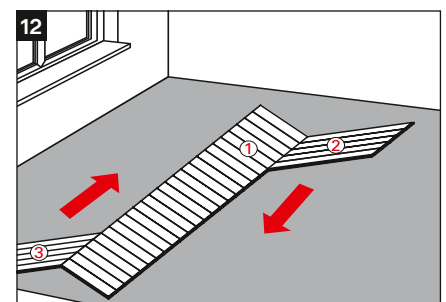

Figure 12: The main alignment of the “first” strand runs along the centre line through the room, whereby the strips continue to be aligned exactly on the centre line. Starting from the centre, lay the strips in extension of the “first” strand precisely along the chalk line up to the opposite wall. Then lay the other strands on the left and right with the groove side (open side) facing the first strand or the other strands.



Assembly

Chevron engineered wood glued over the whole area with tongue and groove connection

Figure 13: Adjust the edge strips with a saw cut at 45° or according to the contours of the wall. Please bear in mind a gap to the wall of 8 –10 mm. This gap required all the way round must also be maintained for fixed installations. We recommend using Parador plastic spacer wedges to maintain the all-round distance to the edge.

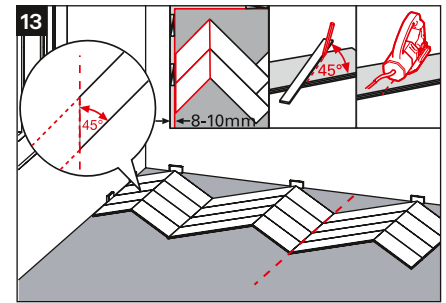

Figure 14: The triangular open spaces that arise on the opposite walls must be filled with suitably cut strips. Please note that the long and end edge areas, which are not held independently due to their shape, must be weighed down until the adhesive has cured in order to avoid protrusions (incorrect adhesions).

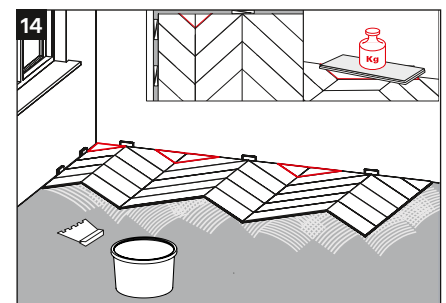

Figure 15 and Figure 16: Once the adhesive has cured (approx. 24 hours), the flooring is ready to walk on. To finish with, you must remove the Parador plastic spacer wedges and attach the Parador skirting board using the clip technology or Parador assembly adhesive.

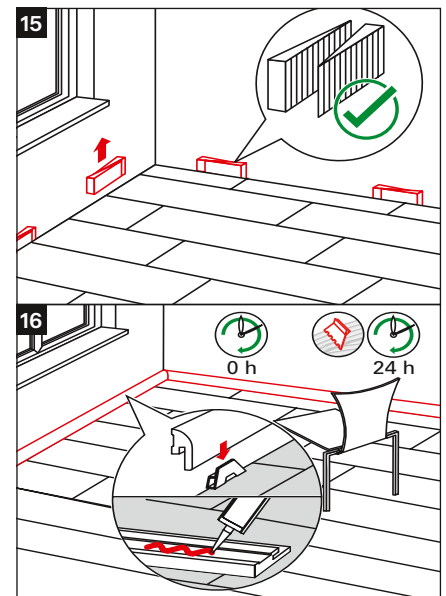
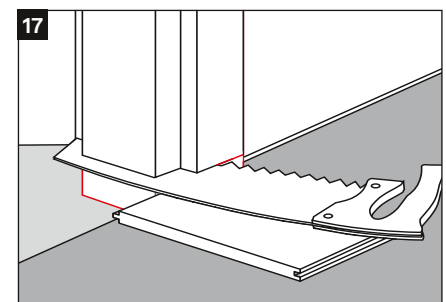

Figure 17: To shorten a door frame, place a leftover piece of chevron strip on an approx. 2 mm high underlay (or on a comparable product) against the frame and saw the frame along the chevron strip. The approx. 2 mm high underlay imitates the height of the adhesive.



Retaining value, cleaning and care

Parador engineered wood floors are easy to clean and maintain thanks to their finished surfaces. In order to enjoy your new floor for a long time, here are a few tips for retaining value, cleaning, and care:

Retaining value

General information on retaining the value of your engineered wood:

- › 30-65% (exception: 40-65% for the beech wood) relative humidity is ideal for Parador engineered wood and also recommended for people's well-being.
- › Avoid sand and dirt as both act like sandpaper.
- › Immediately wipe up liquids resting on the floor.
- › Only wipe with a slightly damp cloth.
- › Do not use any abrasives, floor wax or polishes. Among other things, they tarnish the floor's appearance.
- › Fit chairs and tables with soft felt pads. Office chairs should have soft rollers, otherwise use suitable floor mats in these heavily used areas.
- › Do not use steam cleaners.
- › Please use cleaning and routine care products from the Parador product range.

Preventing damage

As with all other floor coverings, you should protect your new engineered wood from dirt particles by using suitable dirt-trapping zones (mats) (Figure 1). To protect the wood against scratches, suitable soft felt pads must always be fitted under chair legs, table legs and furniture (Figure 2). Rollers on office chairs, filing trolleys and roller containers should be fitted with soft treads/castors (type W in accordance with EN 12529) (Figure 3). There is also the option of protecting the floor in these heavily used areas with suitable mats (available in office supply stores). It is not necessary to wax the lacquered engineered wood or give it an additional seal, as such measures can in no way improve the floor's looks or benefits of use. We recommend that you clean your engineered wood regularly with a vacuum cleaner (attached brushes) or broom. Cleaning with a slightly damp cloth should only be done in case of stubborn dirt. It is important in this case that the cloth is well wrung out and that no puddles form with standing water.

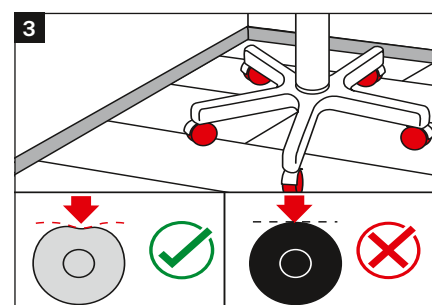
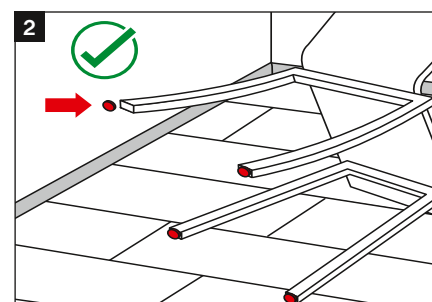
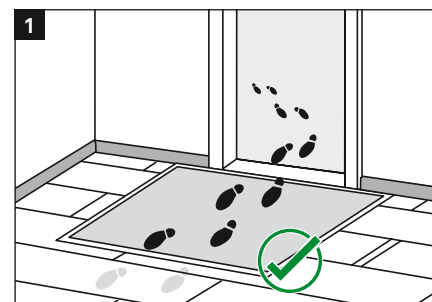

Retaining value, cleaning and care

Final construction cleaning

- › Remove drilling dust and loose particles directly with a broom or vacuum cleaner with attached brushes.
- › If necessary, wipe the floor with a damp cloth using standard cleaning and care products.
- › Ensure that the floor is wiped only damp, never wet.

Routine cleaning

- › Remove dust, fluff and loose particles with a broom or vacuum cleaner with attached brushes.
- › Dirty marks are wiped off with a damp cloth.
- › For routine cleaning and value retention we recommend the Parador care set with special cleaning and care products.
- › In case of stubborn dirt, wipe the floor damp with Parador cleaning products. Only use a cleaning and care product suitable for the respective engineered wood surface from the Parador product range.

Repairing more serious scratches and damages

- › The damaged areas can be repaired with the colour-coordinated Parador Premium repair set.
- › Use the Parador varnish retouching pen to touch up light scratches.

Retaining value, cleaning and care

Maintaining lacquered finishes and natural oil/natural oil plus surfaces/ oil impregnated surfaces (UV oil)/Professional (“contract lacquer”)

Note: The specified care rules also apply to engineered wood with the surface finish extra matt lacquer professional. The care must not deviate from the specifications for the usual lacquered finishes.

Video link - Retaining the value of Parador floor coverings



Note:
Click on the text "Video link",
on the QR code or scan the QR code

Please use products from the Parador range for the care of all engineered wood surfaces. In addition to Parador care products, there are various oil, oil/wax or wax systems available on the market. You should opt for one system. If a system is used in combination with mopping water and/or soaps, make sure that the floor is only ever mopped with a damp cloth, never wet, and that the cloth is always wrung out thoroughly. Avoid puddles and standing water at all costs.

Parador natural oil, natural oil plus and oil impregnated (UV oil) surfaces can be treated with all commercially available cleaning and care products for air-drying or oxidatively drying natural oil surfaces and oil-impregnated (UV oil) surfaces.

With the ready-to-install surface, regardless of the use/loading, initial maintenance is not necessary to retain the value of the flooring over the long term. The maximum oil absorption of the engineered wood plank surface is reached at the factory (see exception below for engineered wood Basic 11-5).

Depending on wear, regular maintenance is, however, always necessary.

Please note the individual processing information and labelling of your preferred supplier.

Retaining value, cleaning and care

Complete renovation through sanding

If the engineered wood is renovated due to damage or other impairments, the entire surface of lacquered engineered wood and oil-impregnated engineered wood (UV oil) must be sanded. With natural oil floors and also with natural oil plus surfaces, this can also be done partially. Depending on the extent of the damage, approx. 0.5 mm is sanded off per sanding process. Engineered wood can therefore be sanded several times without any problems. For the surface treatment required afterwards, you can use appropriate lacquer or oil products from the Parador range or from specialist retailers. A wide variety of surface materials are available as lacquer, oil or wax sealants. You can use all systems that the respective manufacturer recommends for engineered wood floors. A completely sanded off floor can also be treated with Parador Pro care oil for real wood flooring from the Parador product range.

Maintenance of brushed/textured surfaces

Brushed or textured surfaces require more maintenance and are more sensitive to dirt. Pay particular attention to larger dirt-trapping zones here. On textured surfaces, cleaning should be done in the direction of the texture.

For products from the product range Basic 11-5 engineered wood, Parador recommends initial care for long-term maintenance of the original look (please use the profile care oils from the Parador product range).

Template acceptance protocol for professional installers

Mr. / Ms.: _____ Order number: _____

Street: _____ Protocol number: _____

Postcode / town: _____ Date: _____

Installed on: _____

Pos.	Quantity (target)	Quantity (actual)	Article
1	_____ m ²	_____ m ²	Removal of existing coverings/m ² Basis
2	_____ m ²	_____ m ²	Flooring installation
3	_____ m	_____ m	Profile insertion
4	_____ m	_____ m	Attaching skirting boards
5	_____ Pcs.	_____ Pcs.	Shortening doors
6	_____ Pcs.	_____ Pcs.	Shortening door frames
7	_____ Pcs.	_____ Pcs.	Swapping planks

Particularities/remarks: _____

The installed floor was evaluated from a standing position, without angular light or other light refraction (e.g. back-light) and without deviation from the situation of use. The floor shows no signs of defects or damage. The cleaning and care instructions for the installed floor were handed over to the user/client.

 Signature end user and/or orderer

 Date, place

Checklist for installation on hot water underfloor heating

As a matter of principle, all mineral substrates must be heated before installing engineered wood flooring so that damaging moisture can no longer escape. This heating process applies to all times of the year, winter or summer. The screed must be professionally laid according to the generally acknowledged rules of the trade (DIN). It must dry out for at least 21 days before the heating process can begin. We recommend heating the screed according to the following diagram or using the heating protocol template. Please observe additional information given by your screed layer and heating engineer.

Note: See also the section on installation options:
 installation on Underfloor heating system

Heating diagram for a hot water underfloor heating system

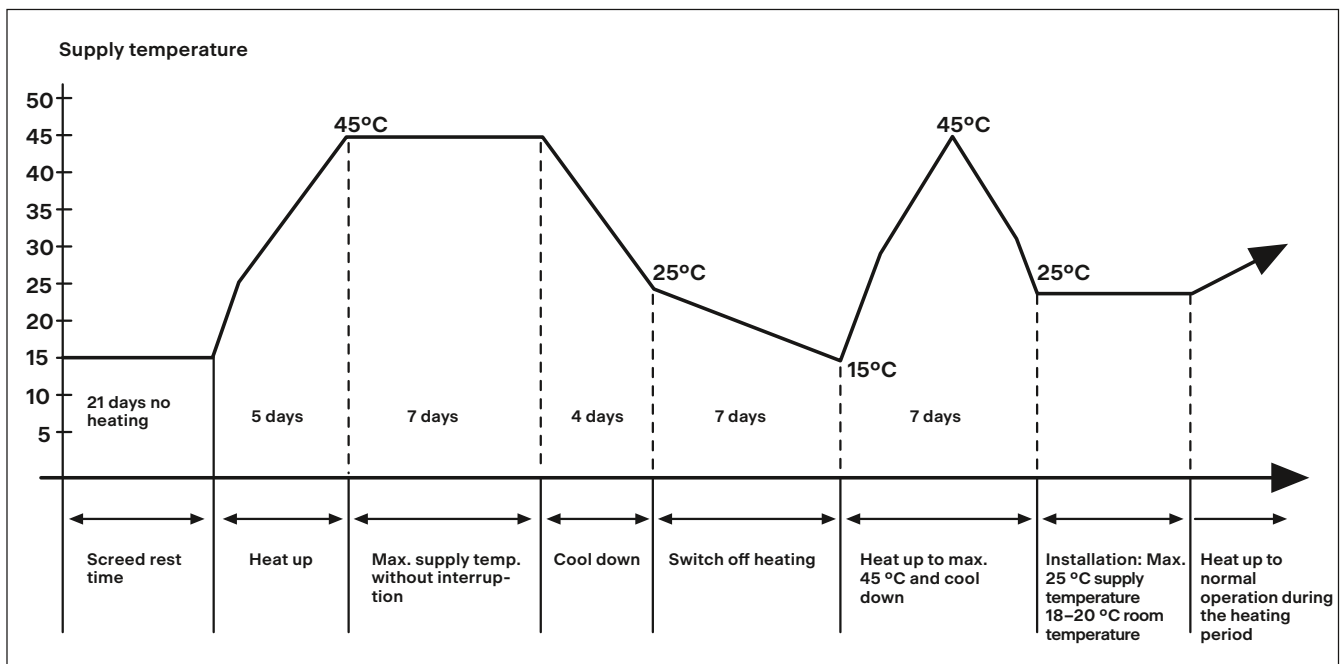

Please bear in mind: The surface temperature of the engineered wood should ideally not exceed 25 °C (max. 29 °C).

Heating protocol for hot water underfloor heating systems (template)

It is essential to keep a heating protocol for newly installed hot water underfloor heating systems.

1. a) The screed work was finished on _____.
- b) It is a cement , anhydrite screed.
- c) The average thickness of the screed is _____ cm.
2. a) The heated floor construction was put into operation on _____ and heated up to 45 °C with a daily temperature increase of 5 °C (supply temperature).
- b) This maximum temperature was maintained for _____ days (target: 7 days) without lowering the temperature at night.
- c) From _____ to _____ (target: 4 days), the supply temperature was reduced by 5 °C a day.
- c) From _____ to _____ (target: 7 days), the heater was shut off.
- e) The heater was started again on _____ and on _____ the supply temperature of 45 °C was reached.
- f) After reaching the supply temperature of 45 °C, the supply temperature was reduced in temperature steps of max. 10 °C a day (max. 25 °C) until the room temperature reached approx. 18 – 20 °C for the installation of laminate and engineered wood.
3. During the heating and cooling off period, were the rooms ventilated but draughts prevented? yes
4. The last moisture measurements at the measuring points marked showed _____ % residual moisture. (Permitted values: anhydrite screed max. 0.3 CM %, cement screed max. 1.8 CM %)
5. The heated floor surface is hereby approved for the installation of wear layers/floor coverings.

For the builder/client:

Place/date/signature/stamp

The notes are used to advise the installer/heating engineer and the builder. Warranty claims cannot be derived from this. In case of doubt, corresponding regulations stipulated by the screed layer/heating engineer must be followed.

Checklist for whole-area gluing of Parador engineered wood



Alternatively, Parador engineered wood can also be glued down over the whole area. The products Trendtime 3 and Selected are designed for whole-area gluing and not suitable for floating installation. Whole-area gluing offers several advantages over a floating installation. Please note the following information:

- › As a surface area adhesive, only water and solvent-free, one or bi-component (1-C or 2-C) polyurethane adhesives recommended for this purpose by the adhesive manufacturer, or solvent-based adhesives in accordance with DIN 281, should be used. The adhesive manufacturer's specifications, particularly with regard to applying the adhesive (e.g. using the appropriate adhesive spatula) must be observed.
- › Parador recommends the adhesives T54 FC and 151 Objekt made by Sika. These adhesives are suitable for all common types of wood, such as beech or oak. Please contact the adhesive manufacturer in case of questions and use the corresponding technical data sheet as a guide.
- › The subfloor must be dry, level, free of cracks, clean and suitable for gluing and must be below the appropriate humidity values. Pre-treatment depends on the adhesive manufacturer's specifications.
- › Screeds must not exceed the following moisture level:

	Anhydrite screed	Cement screed
without underfloor heating	max. 0.5 CM %	max. 2.0 CM %
with underfloor heating	max. 0.3 CM %	max. 1.8 CM %
- › A clearance of at least 10 mm must be maintained from all fixed objects (see installation rules 6 and 7).
- › Movement joints in the subfloor must be transferred. In addition, movement joints are recommended in all doorways, room passages and every 15 m (in lengthways and crossways direction).
- › The general notes from the assembly instructions should also be observed when gluing the whole area.
- › You can find further information on the adhesive manufacturer's website (e.g. www.sika.de) or contact Parador Application Technology in case of doubt.

Eco-Flooring Taterra | Eco-Flooring
Modular ONE | Engineered wood |
Vinyl flooring | Laminated flooring |
Panels | Stairs treads | Skirting boards
| Profiles and accessories

Parador GmbH
Millenkamp 7-8
48653 Coesfeld
Germany

Hotline +49 (0)2541 736 678
info@parador.de
parador.de/en
  

Status: 01/2026 © Parador
Subject to errors and alterations