

Weldless Steel Tank 6 Liter Type A (1,6 Gallon)

mm [in]

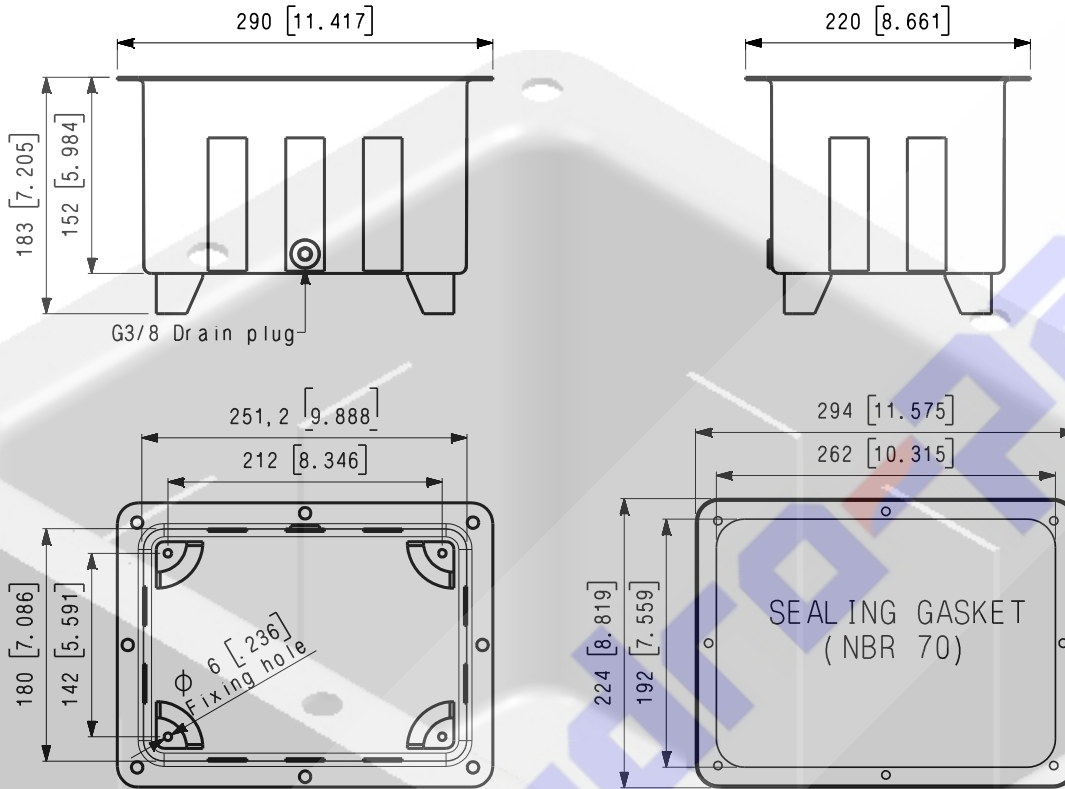

Lid 6 Liter (1,6 Gallon)

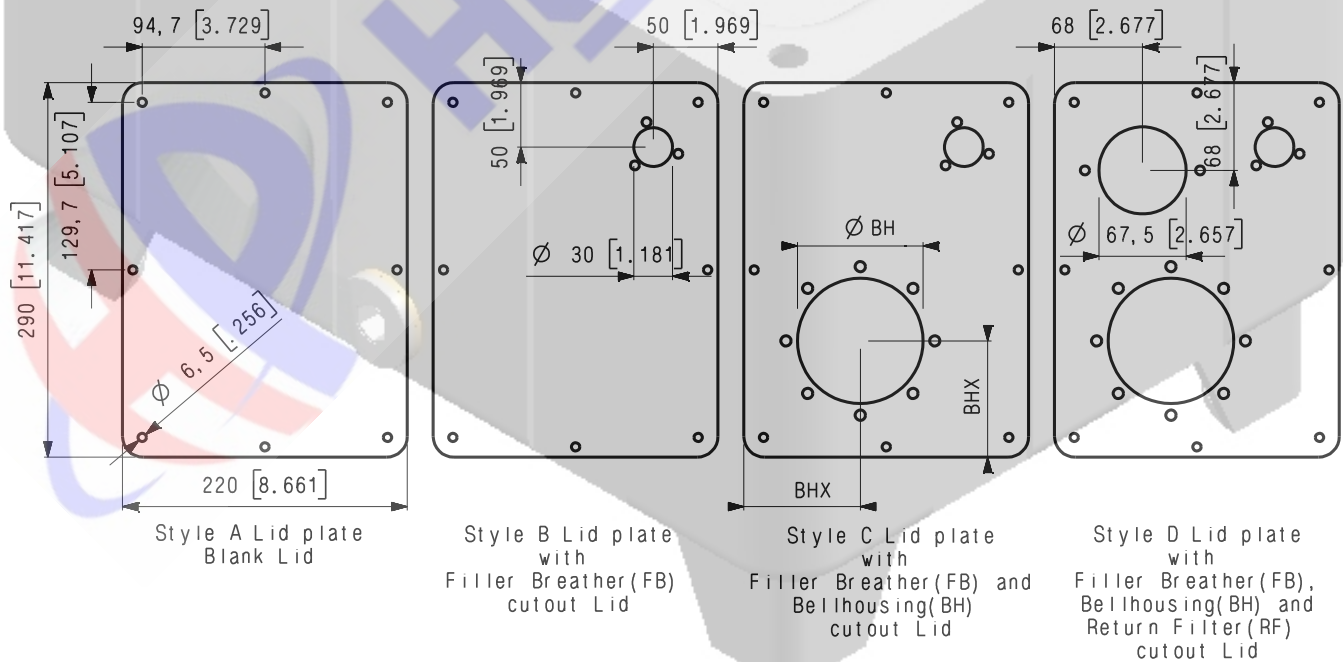

Weldless Steel Tank 6 Liter Type B (1,6 Gallon)

mm [in]

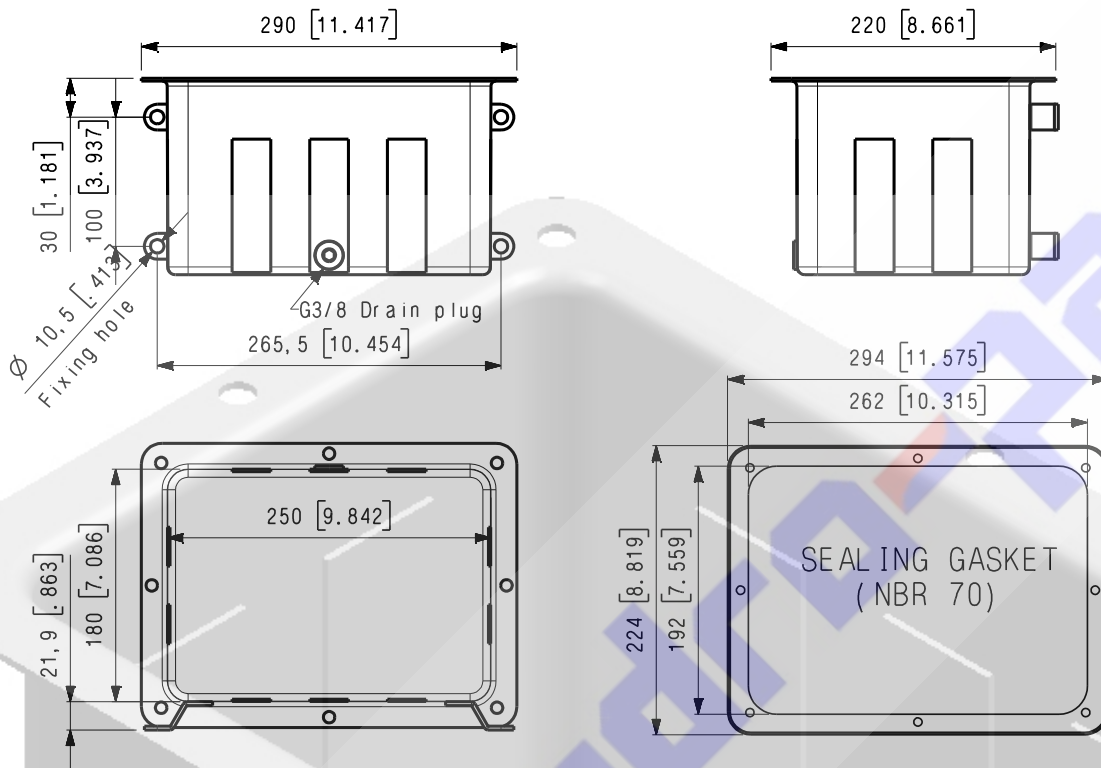

Lid 6 Liter (1,6 Gallon)

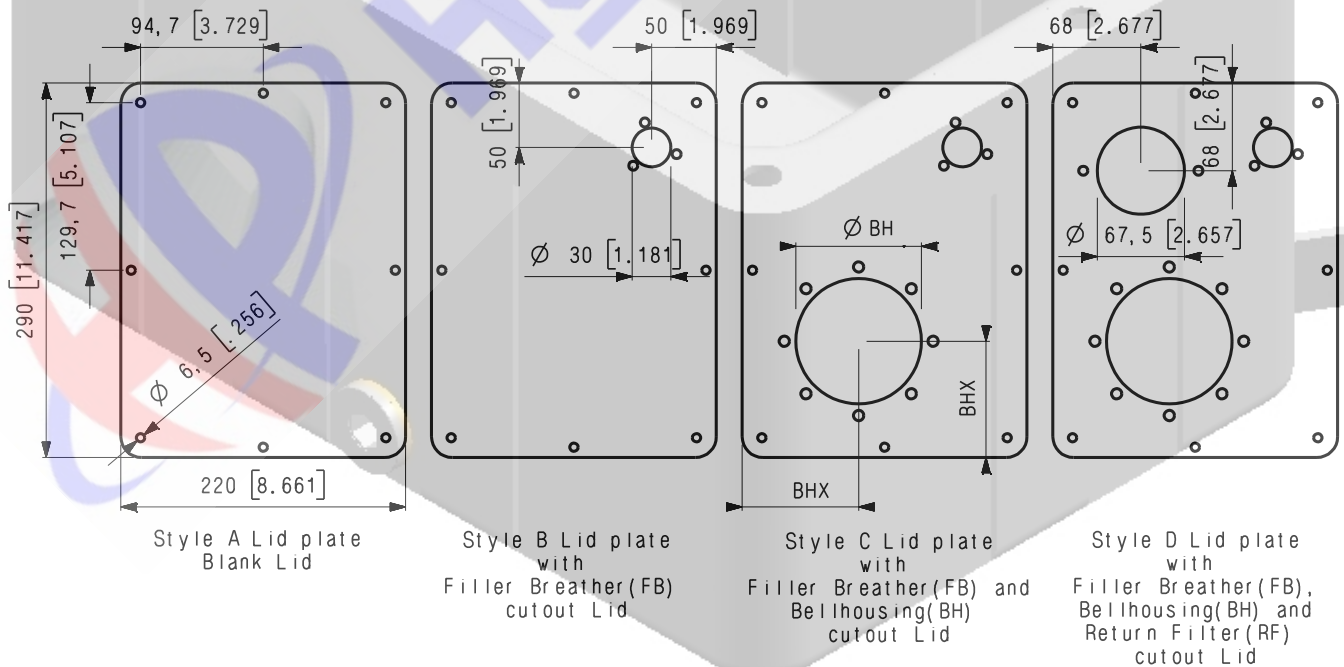

Weldless Steel Tank 12 Liter Type A (3,2 Gallon)

mm [in]

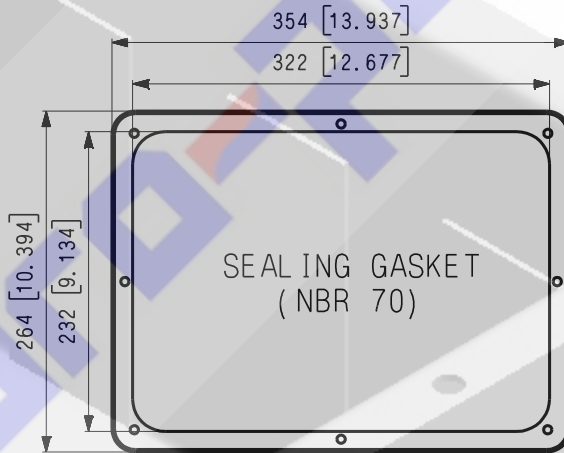
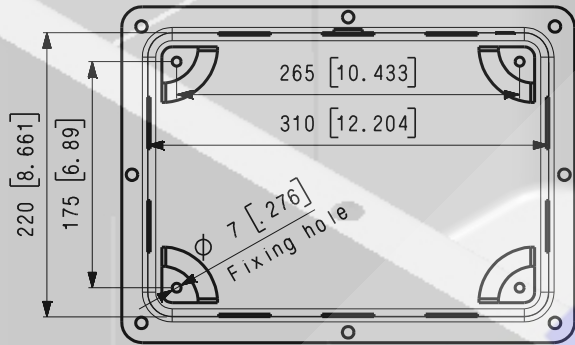
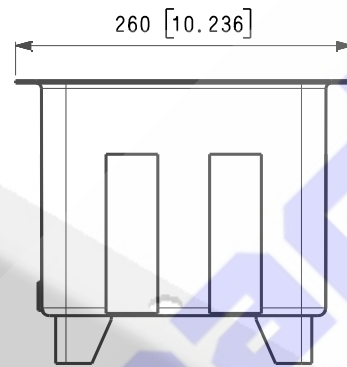
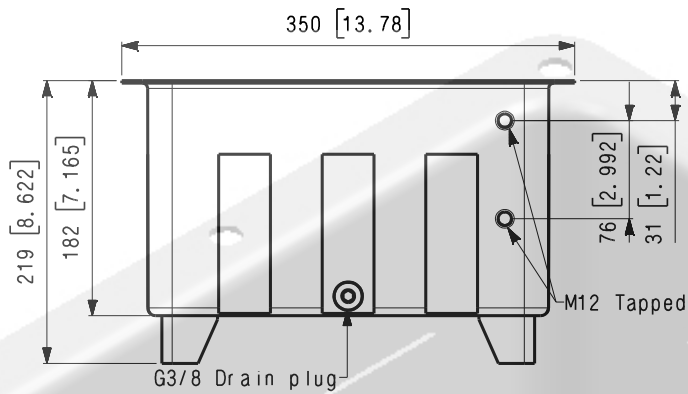

Lid 12 Liter (3,2 Gallon)

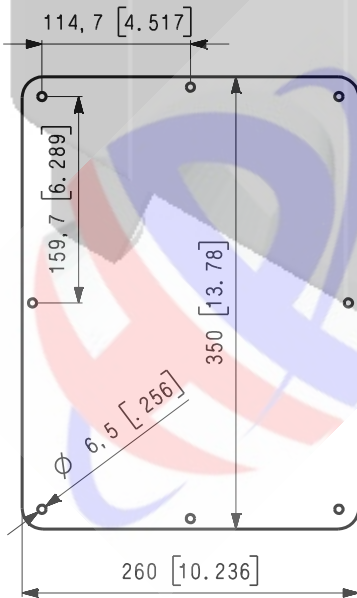

Style A Lid plate
Blank Lid

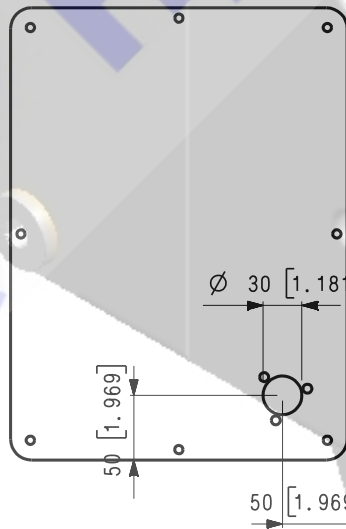

Style B Lid plate
with
Filler Breather (FB) cutout Lid

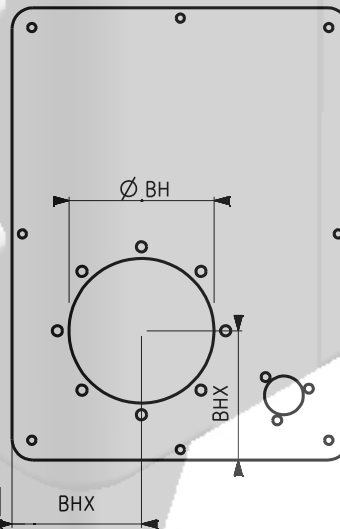

Style C Lid plate
with
Filler Breather (FB) and
Return Filter (RF) cutout Lid

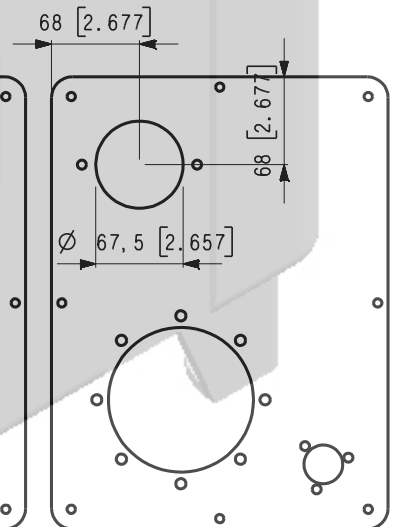

Style D Lid plate
with
Filler Breather (FB),
Bellhousing (BH) and
Return Filter (RF) cutout Lid

Weldless Steel Tank 12 Liter Type B (3,2 Gallon)

mm [in]

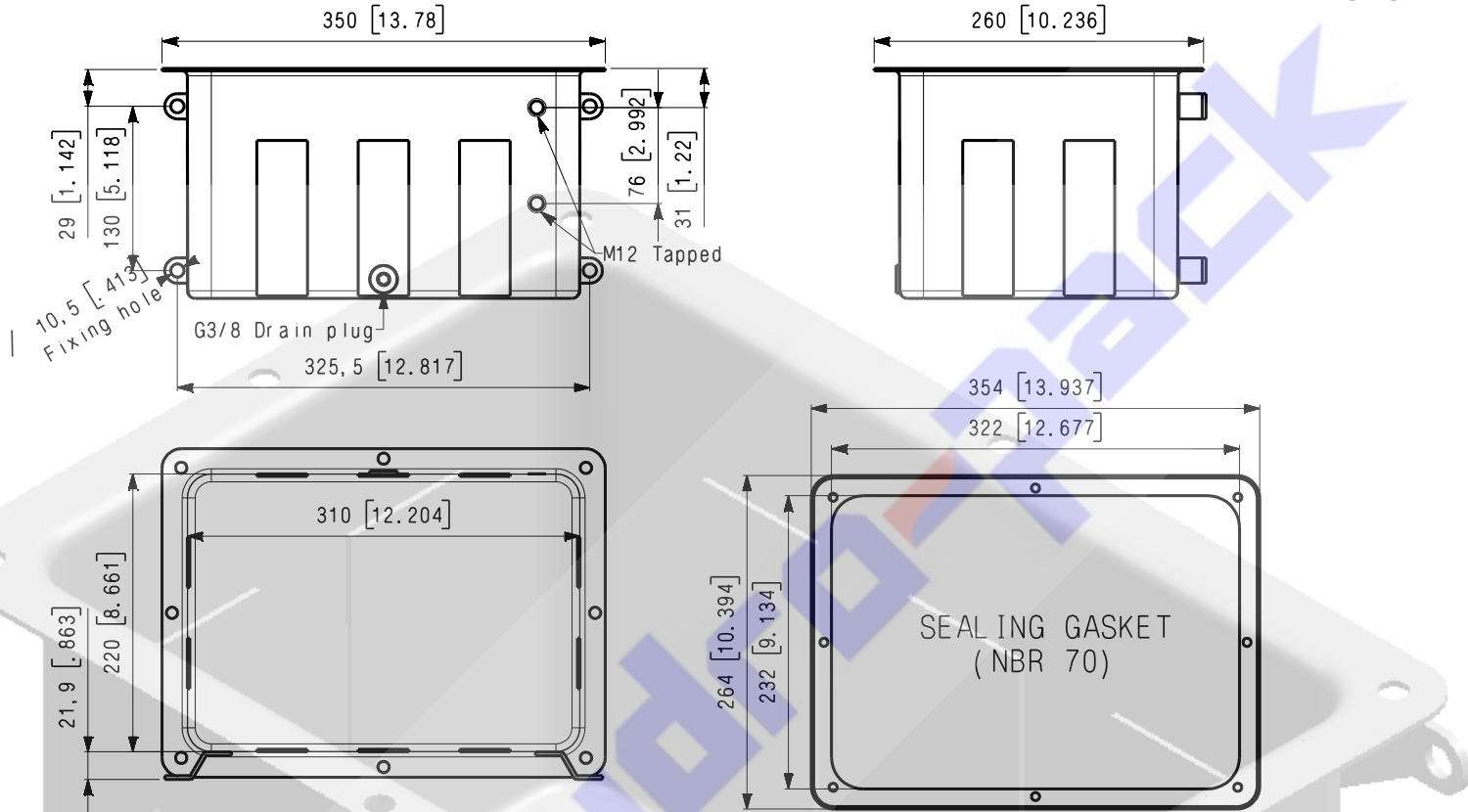

Lid 12 Liter (3,2 Gallon)

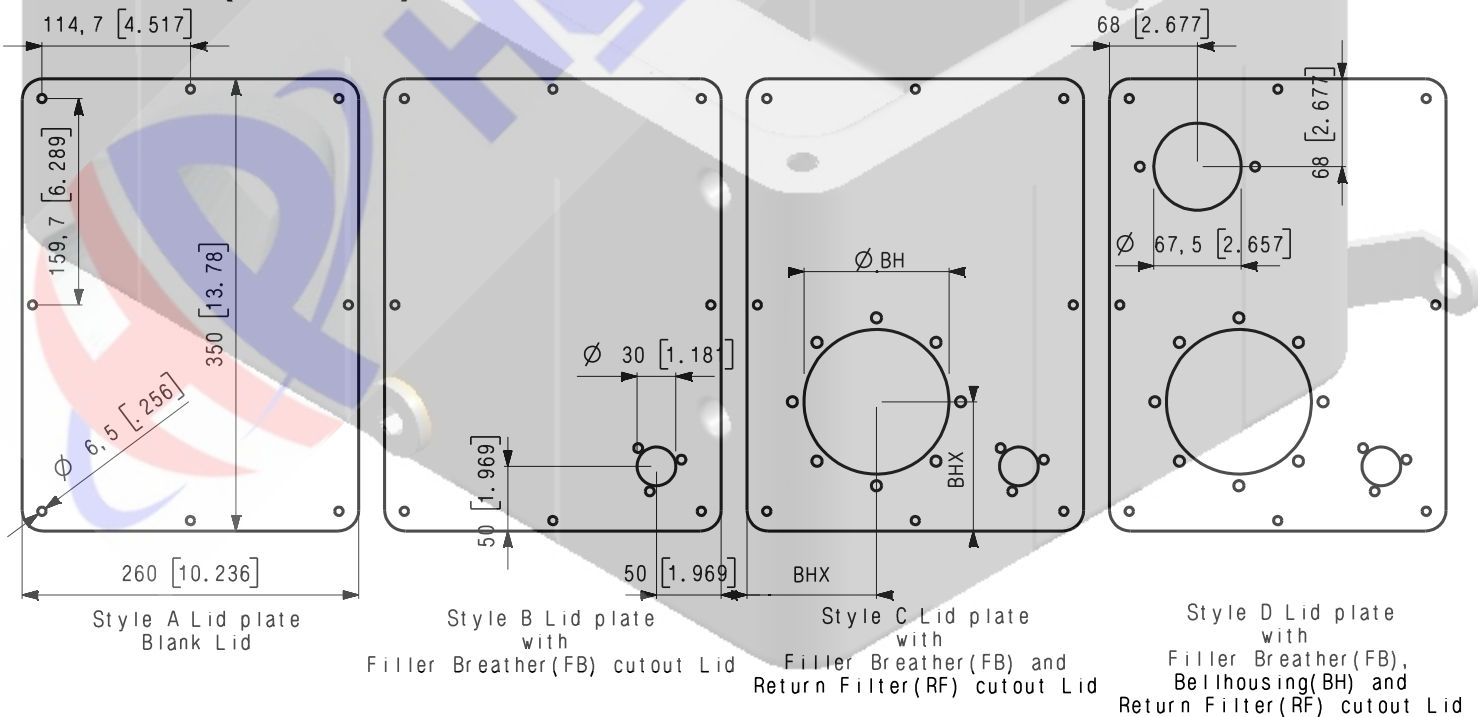

Weldless Steel Tank 25 Liter (6,6 Gallon)

mm [in]

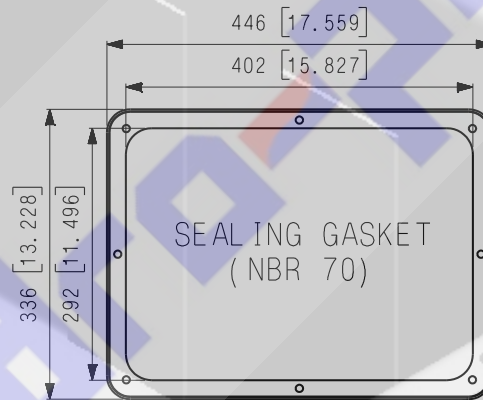
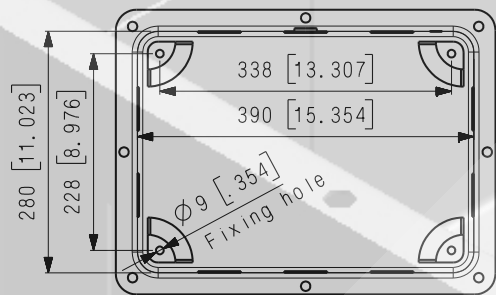
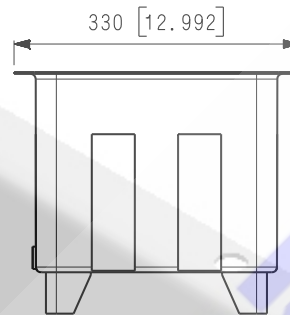
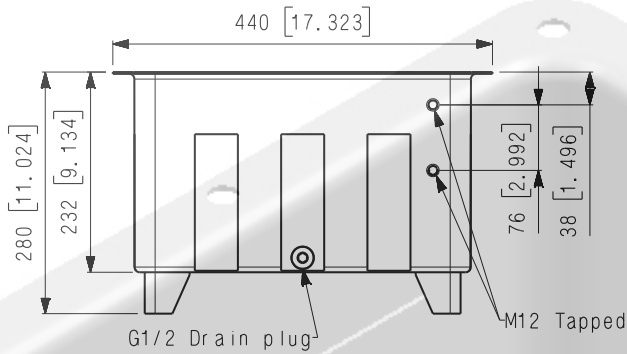

Lid 25 Liter (6,6 Gallon)

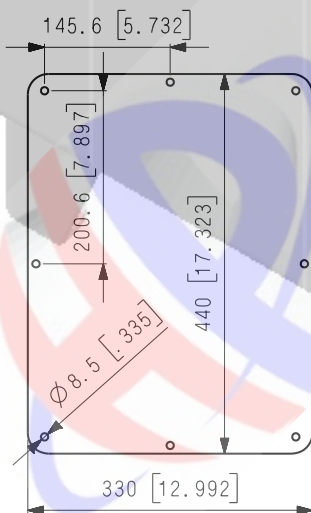

Style A Lid plate
Blank Lid

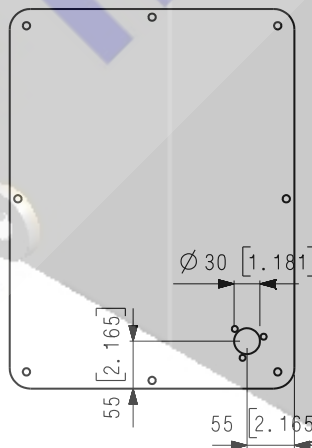

Style B Lid plate
with
Filler Breather (FB)
cutout Lid

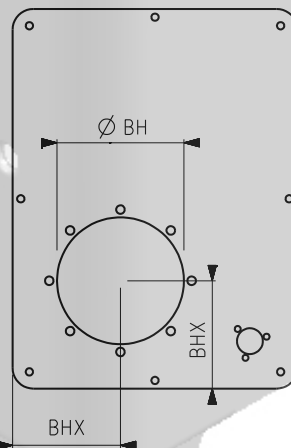

Style C Lid plate
with
Filler Breather (FB) and
Bellhousing (BH)
cutout Lid

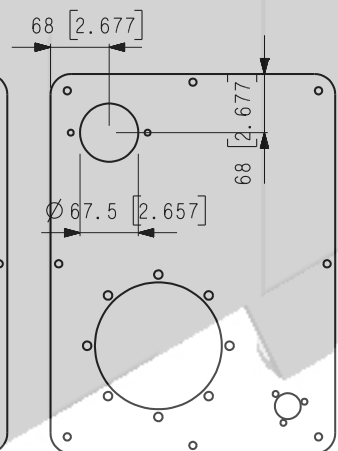

Style D Lid plate
with
Filler Breather (FB),
Bellhousing (BH) and
Return Filter (RF)
cutout Lid

Weldless Steel Tank 40 Liter (10,6 Gallon)

mm [in]

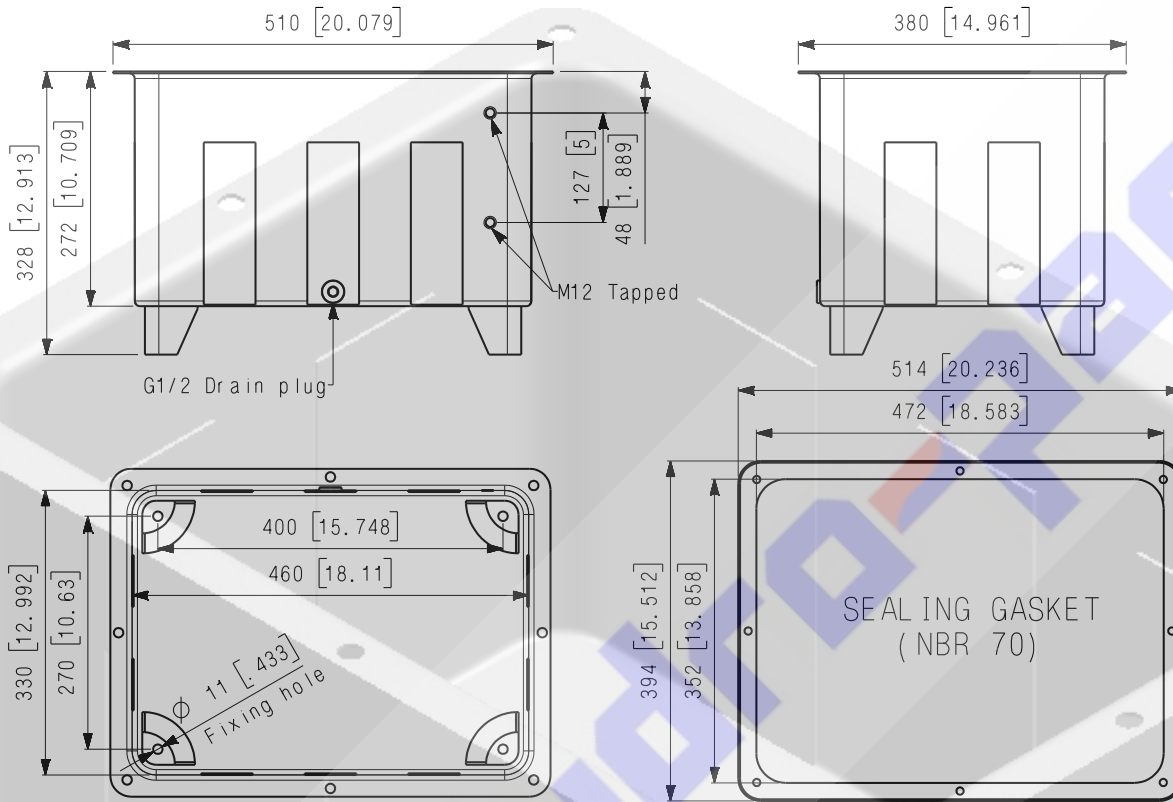

Lid 40 Liter (10,6 Gallon)

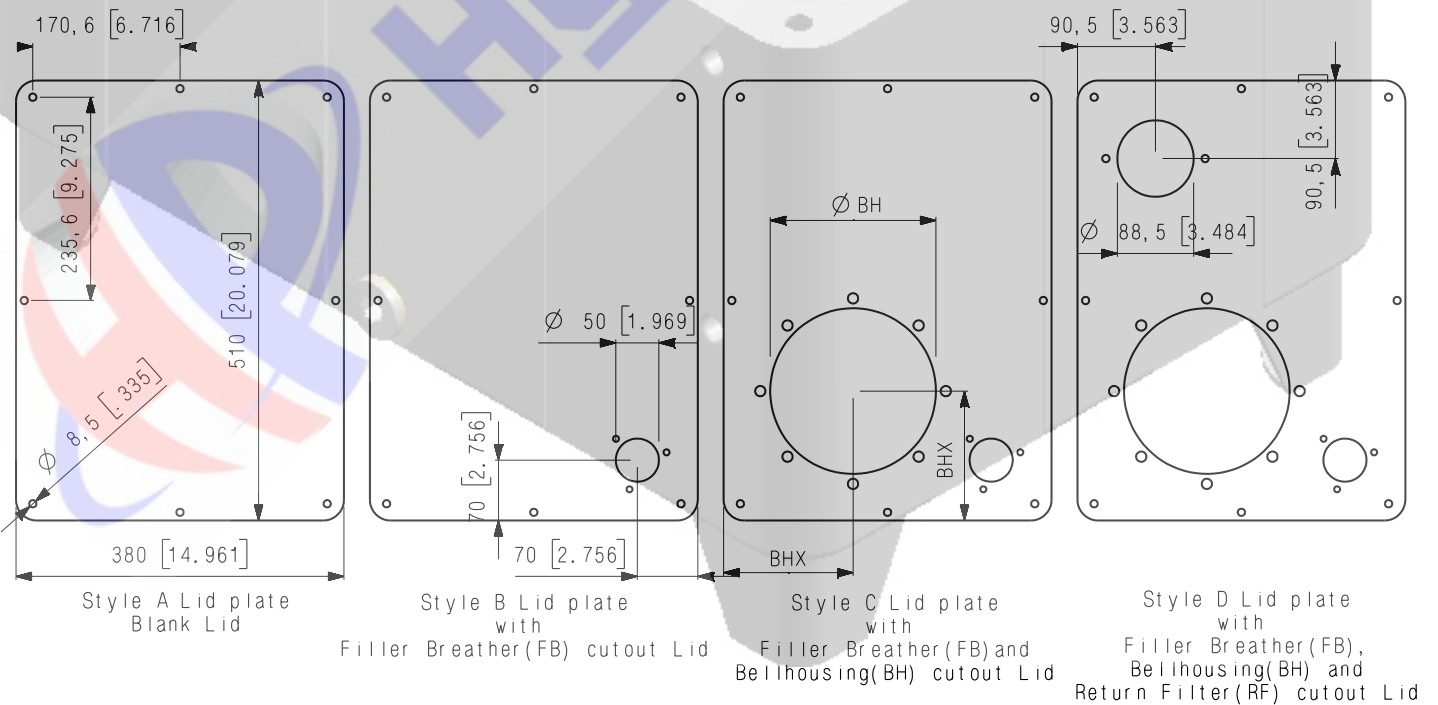

Weldless Steel Tank 70 Liter Type A (18,5 Gallon)

mm [in]

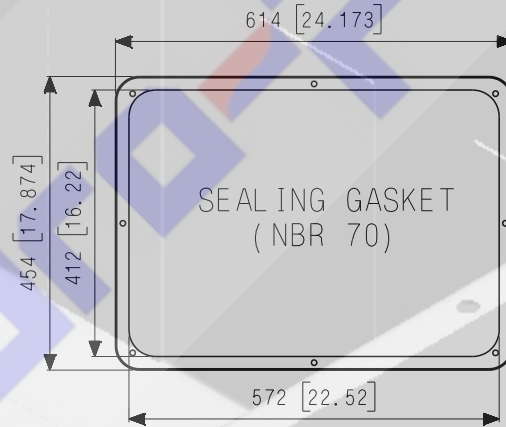
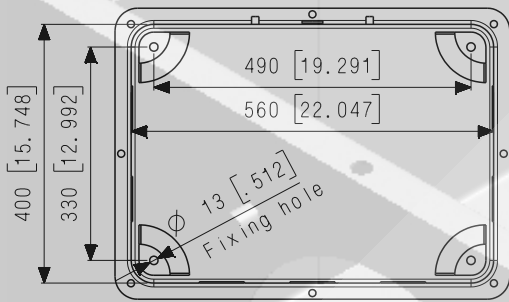
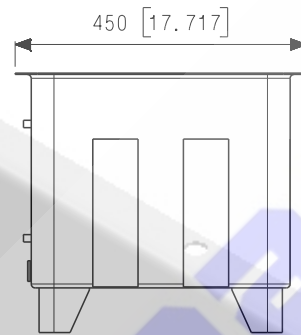
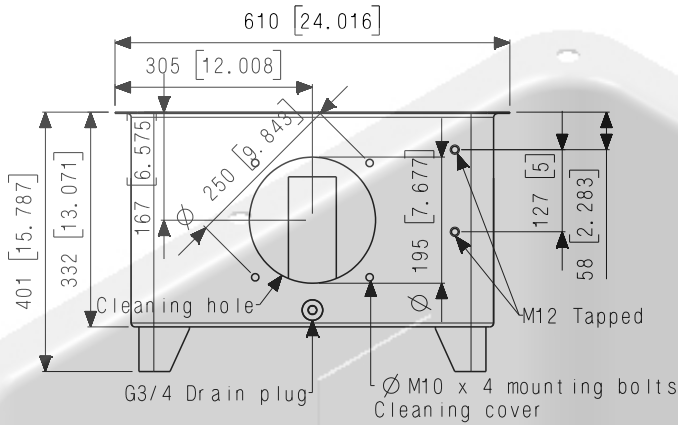

Lid 70 Liter (18,5 Gallon)

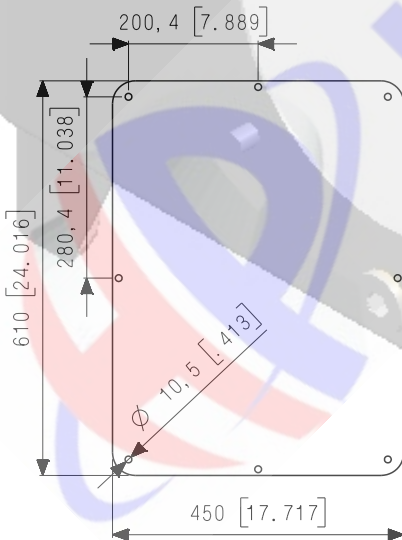

Style A Lid plate
Blank Lid

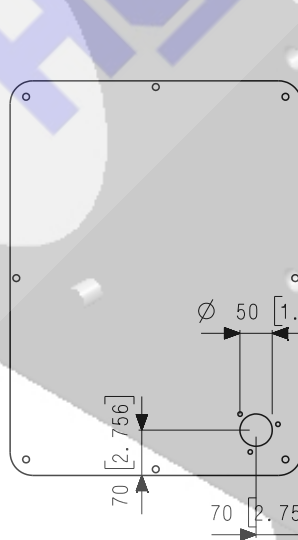

Style B Lid plate
with
Filler Breather (FB)
cutout Lid

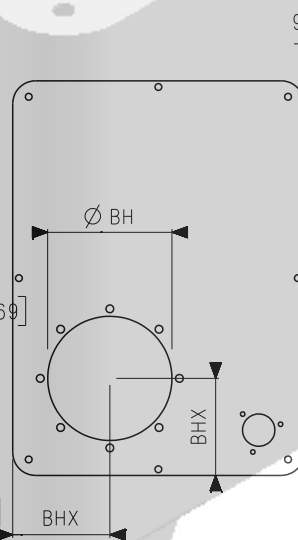

Style C Lid plate
with
Filler Breather (FB) and
Bellhousing (BH)
cutout Lid

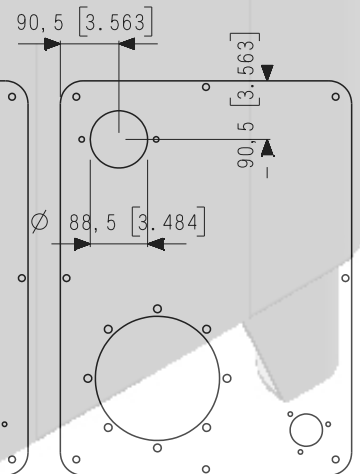

Style D Lid plate
with
Filler Breather (FB),
Bellhousing (BH) and
Return Filter (RF)
cutout Lid

Weldless Steel Tank 70 Liter Type B (18,5 Gallon)

mm [in]

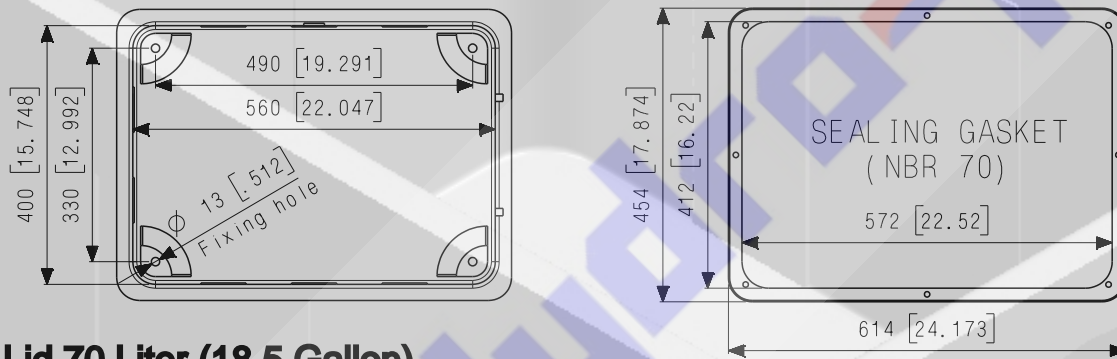
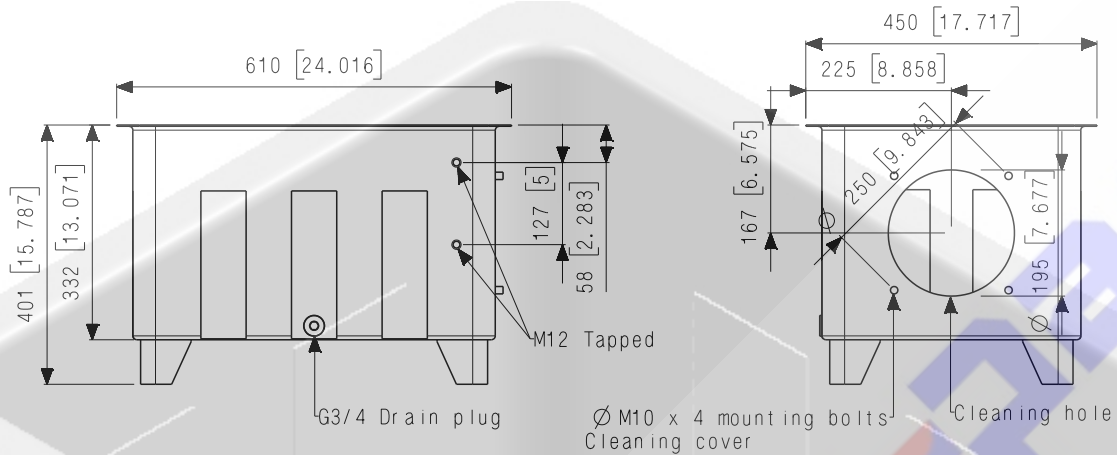

Lid 70 Liter (18,5 Gallon)

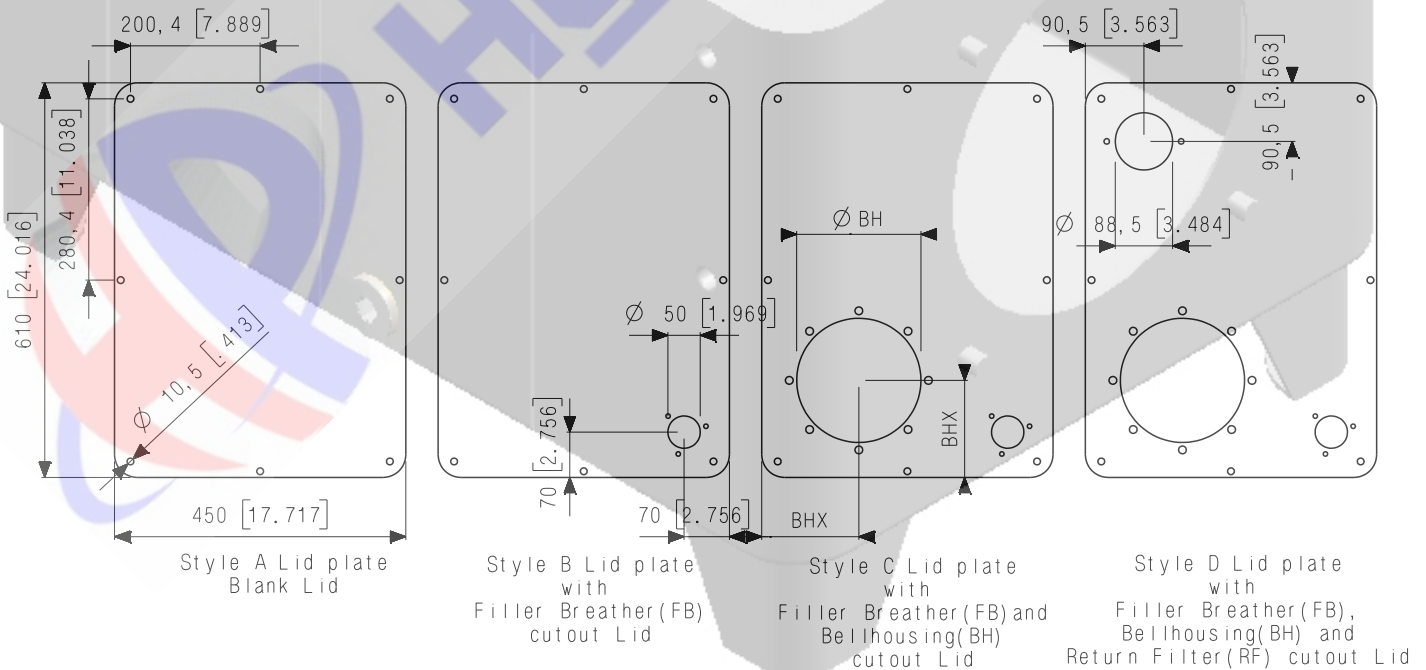

Weldless Steel Tank 70 Liter Type C (18,5 Gallon)

mm [in]

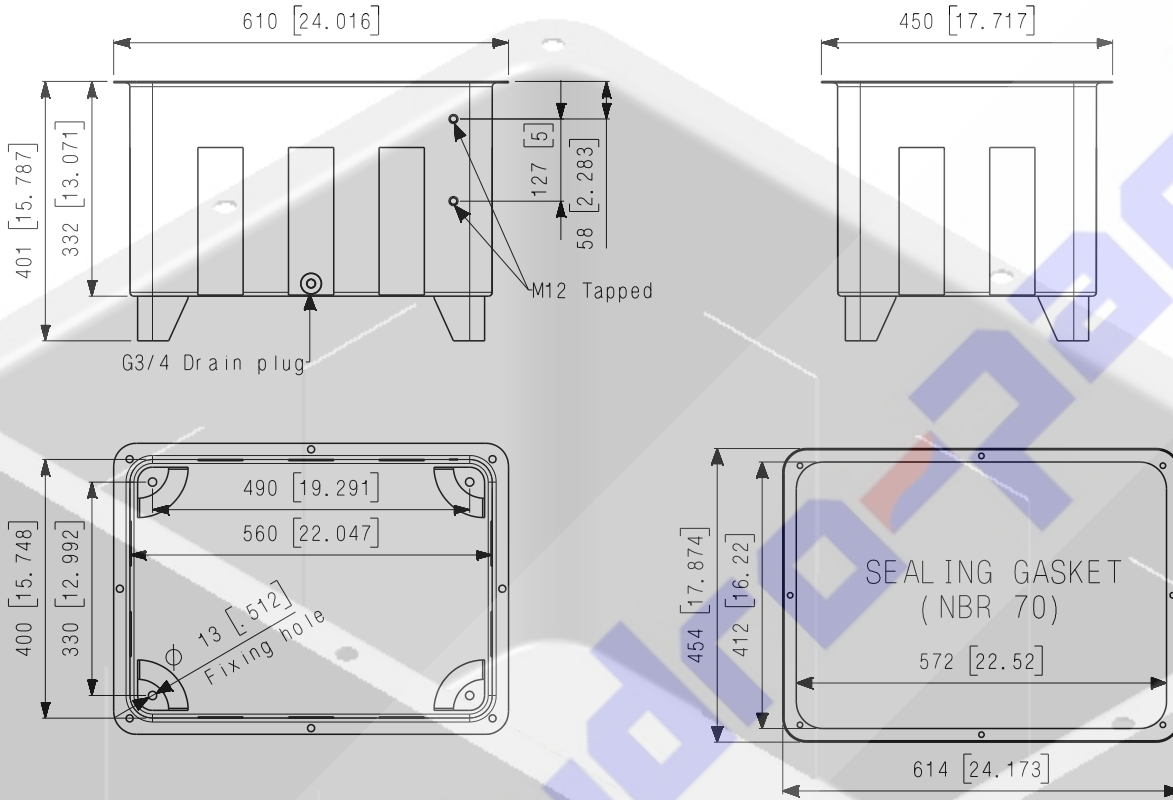

Lid 70 Liter (18,5 Gallon)

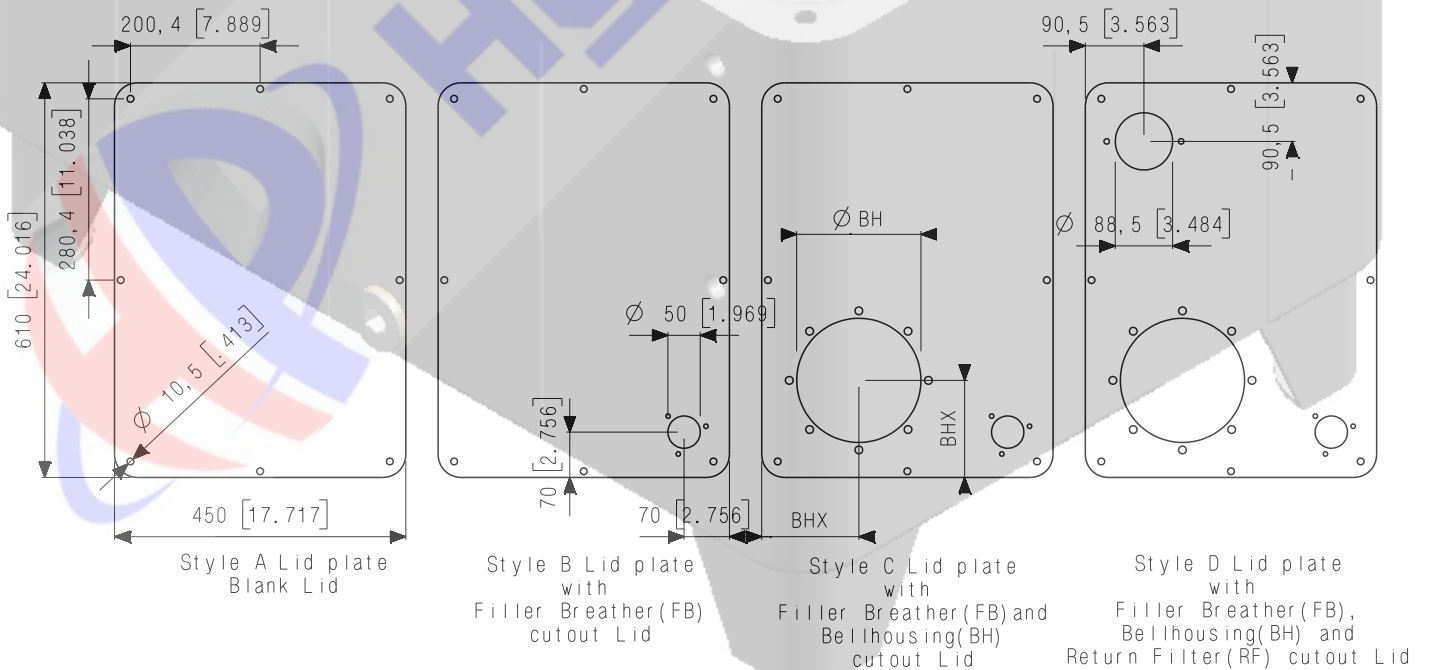

Weldless Steel Tank 100 Liter Type A (26,4 Gallon)

mm [in]

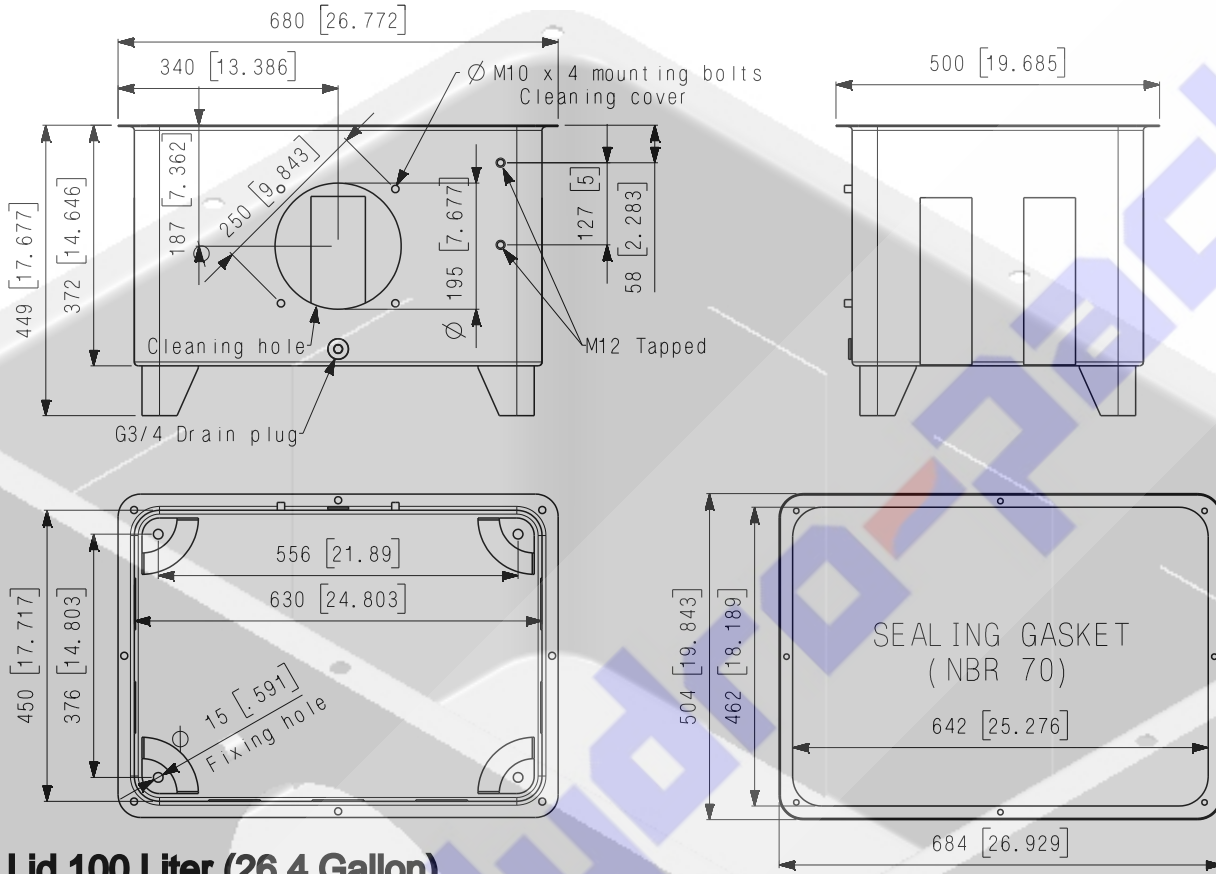

Lid 100 Liter (26,4 Gallon)

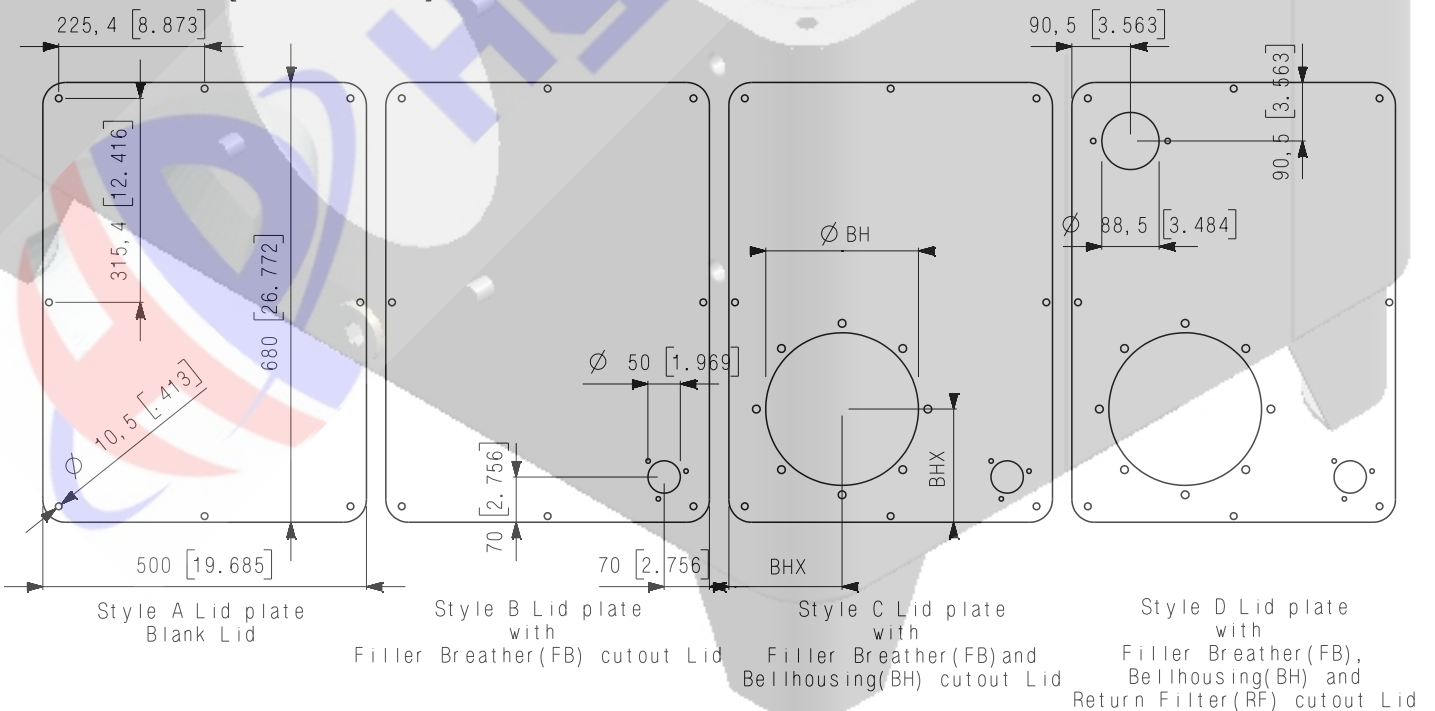

Weldless Steel Tank 100 Liter Type B (26,4 Gallon)

mm [in]

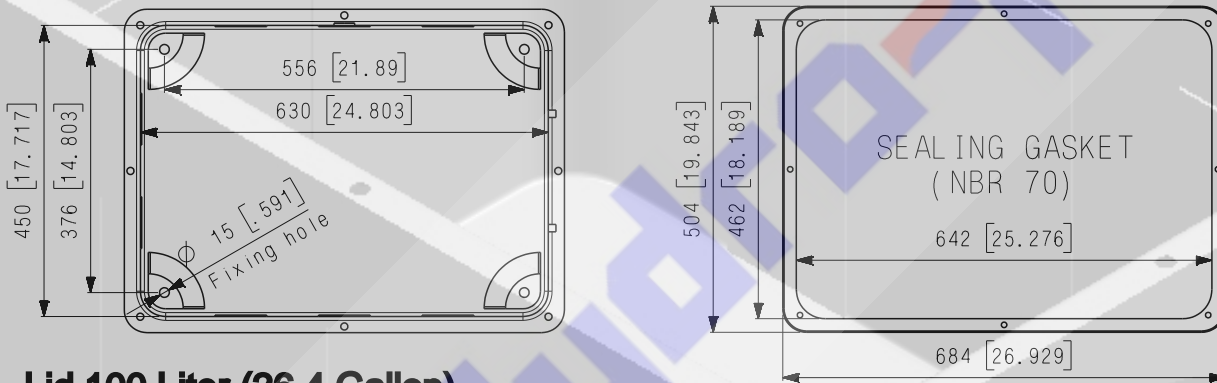
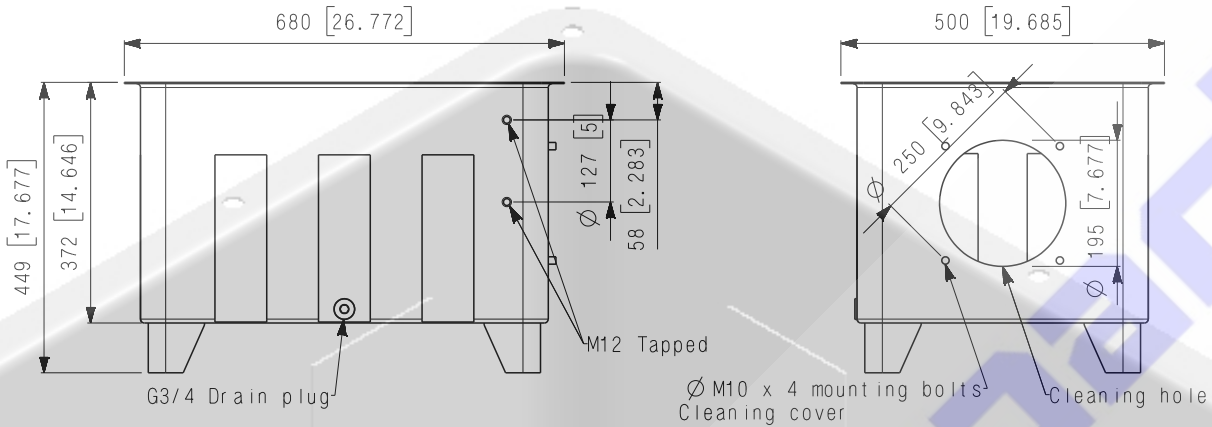

Lid 100 Liter (26,4 Gallon)

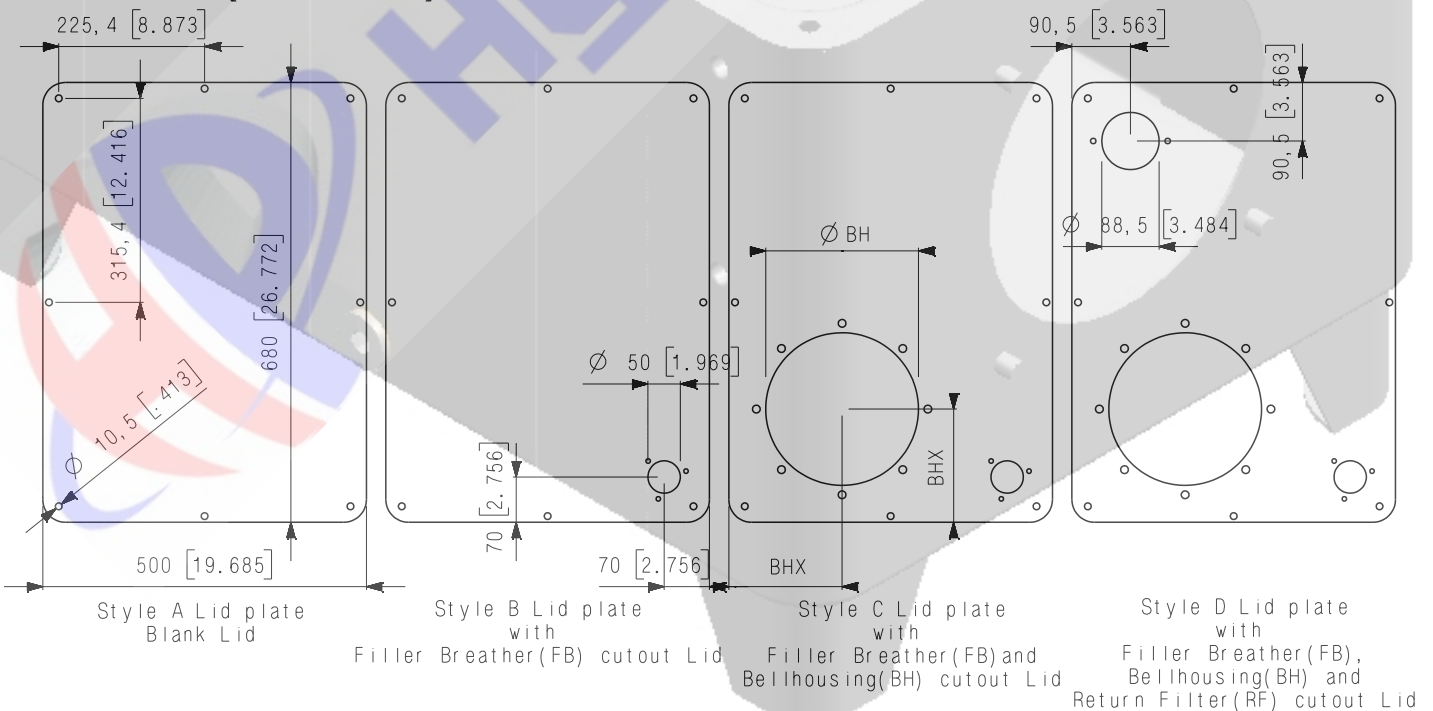

Weldless Steel Tank 100 Liter Type C (26,4 Gallon)

mm [in]

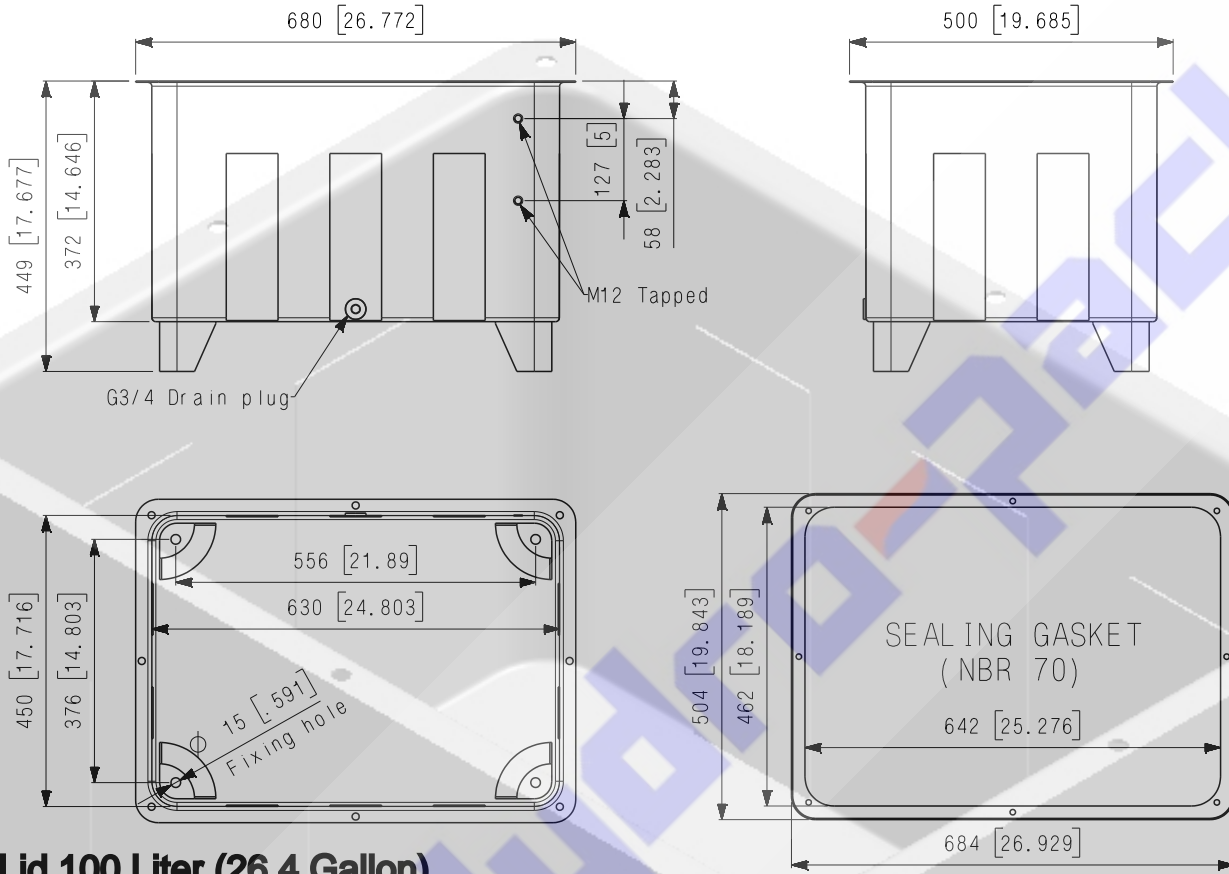

Lid 100 Liter (26,4 Gallon)

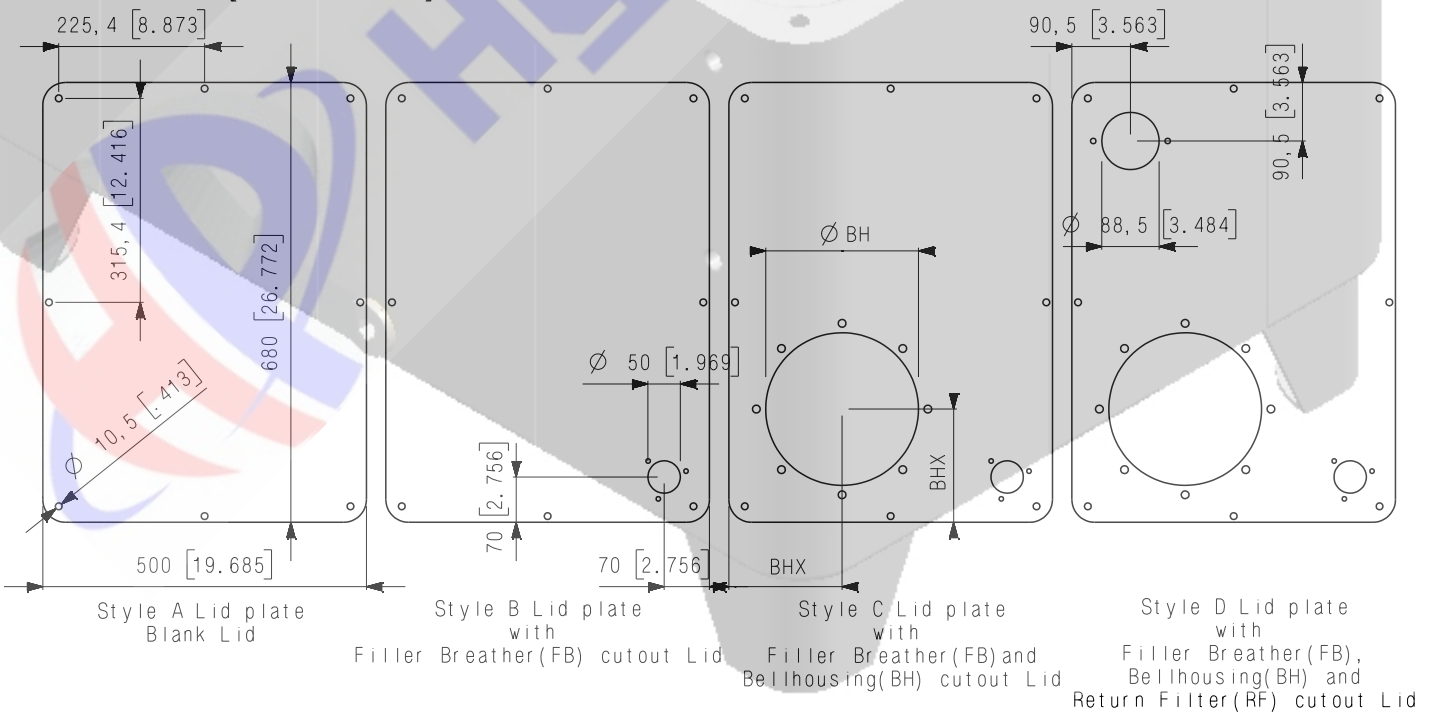

Weldless Steel Tank 160 Liter Type A (42,3 Gallon)

mm [in]

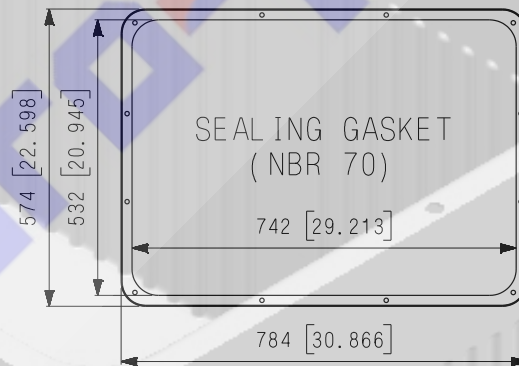
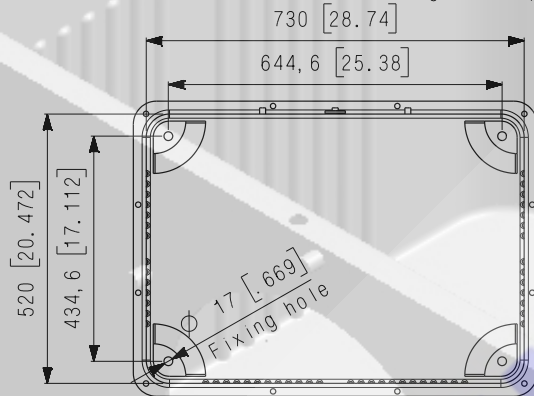
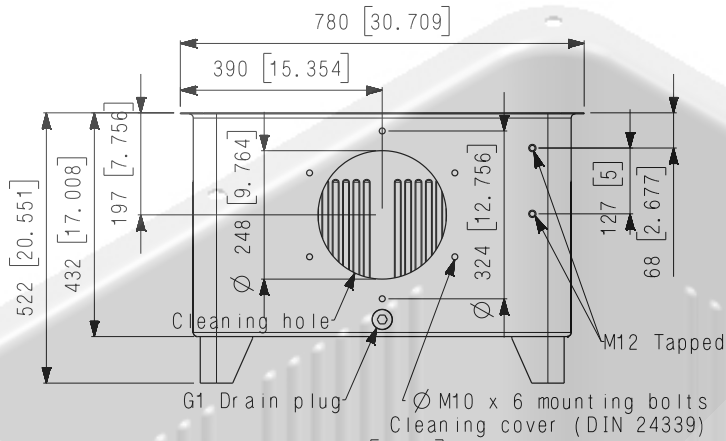

Lid 160 Liter (42,3 Gallon)

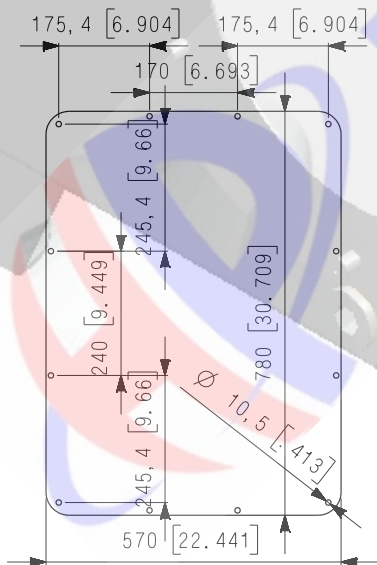

Style A Lid plate
Blank Lid

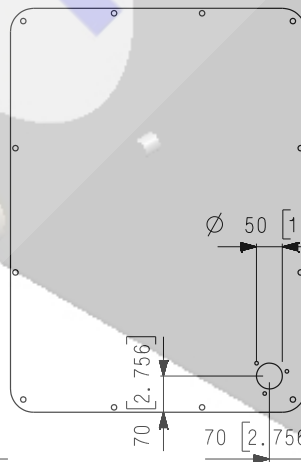

Style B Lid plate
with
Filler Breather (FB)
cutout Lid

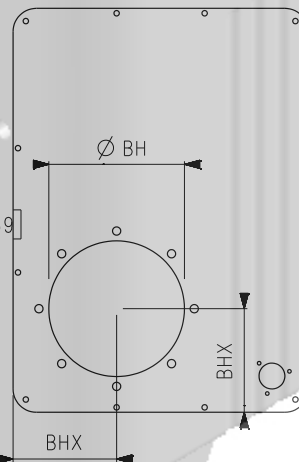

Style C Lid plate
with
Filler Breather (FB) and
Bellhousing (BH)
cutout Lid

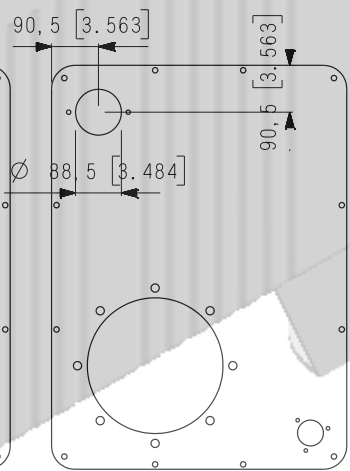

Style D Lid plate
with
Filler Breather (FB),
Bellhousing (BH) and
Return Filter (RF)
cutout Lid

Weldless Steel Tank 160 Liter Type B (42,3 Gallon)

mm [in]

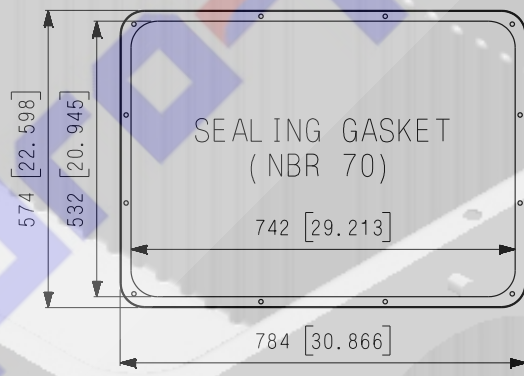
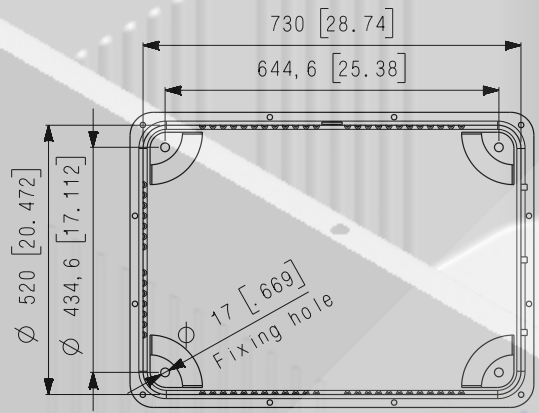
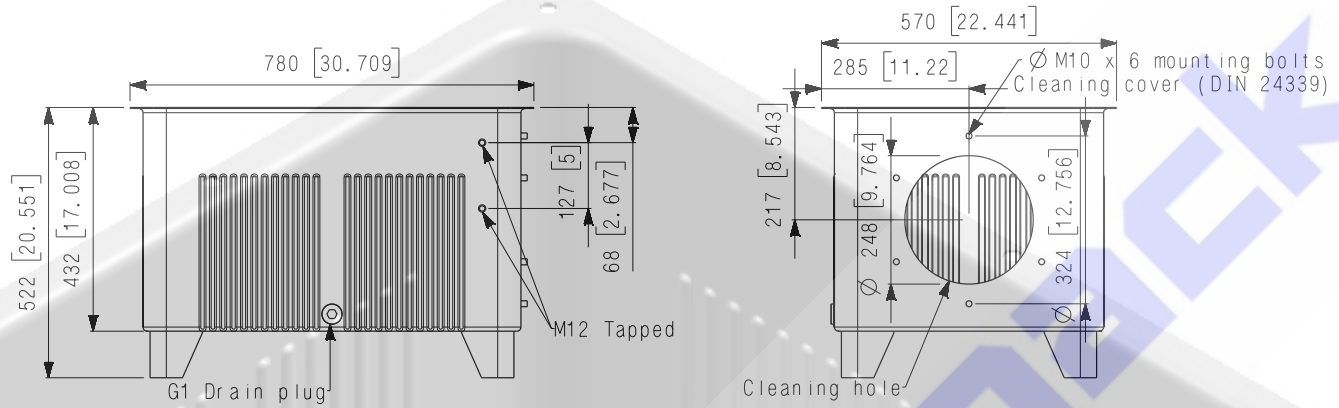

Lid 160 Liter (42,3 Gallon)

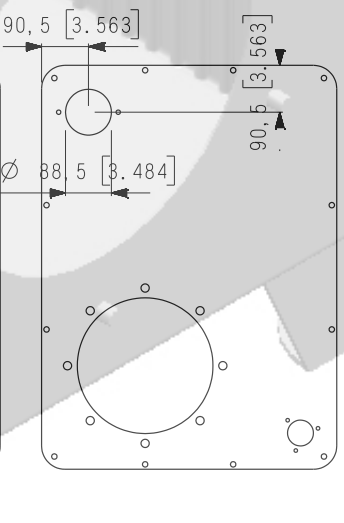
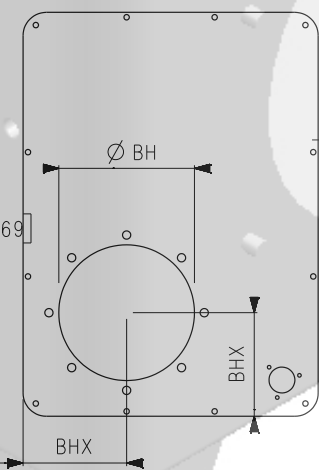
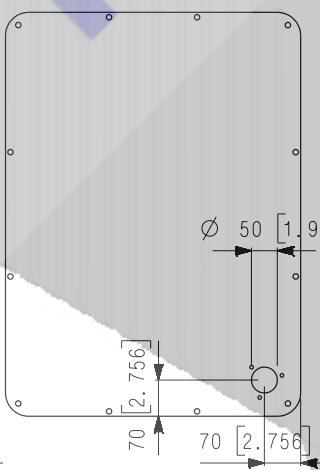
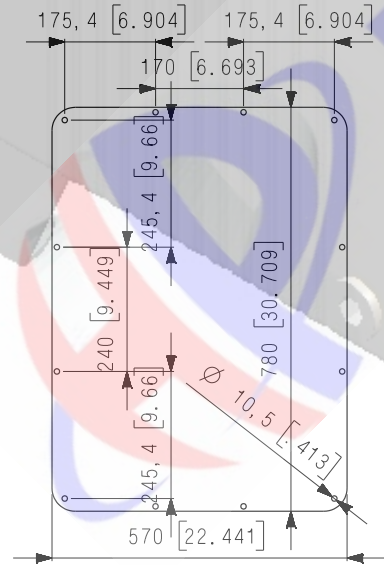

Style A Lid plate Blank Lid

Style B Lid plate with Filler Breather (FB) cutout Lid

Style C Lid plate with Filler Breather (FB) and Bellhousing (BH) cutout Lid

Style D Lid plate with Filler Breather (FB), Bellhousing (BH) and Return Filter (RF) cutout Lid

Weldless Steel Tank 160 Liter Type C (42,3 Gallon)

mm [in]

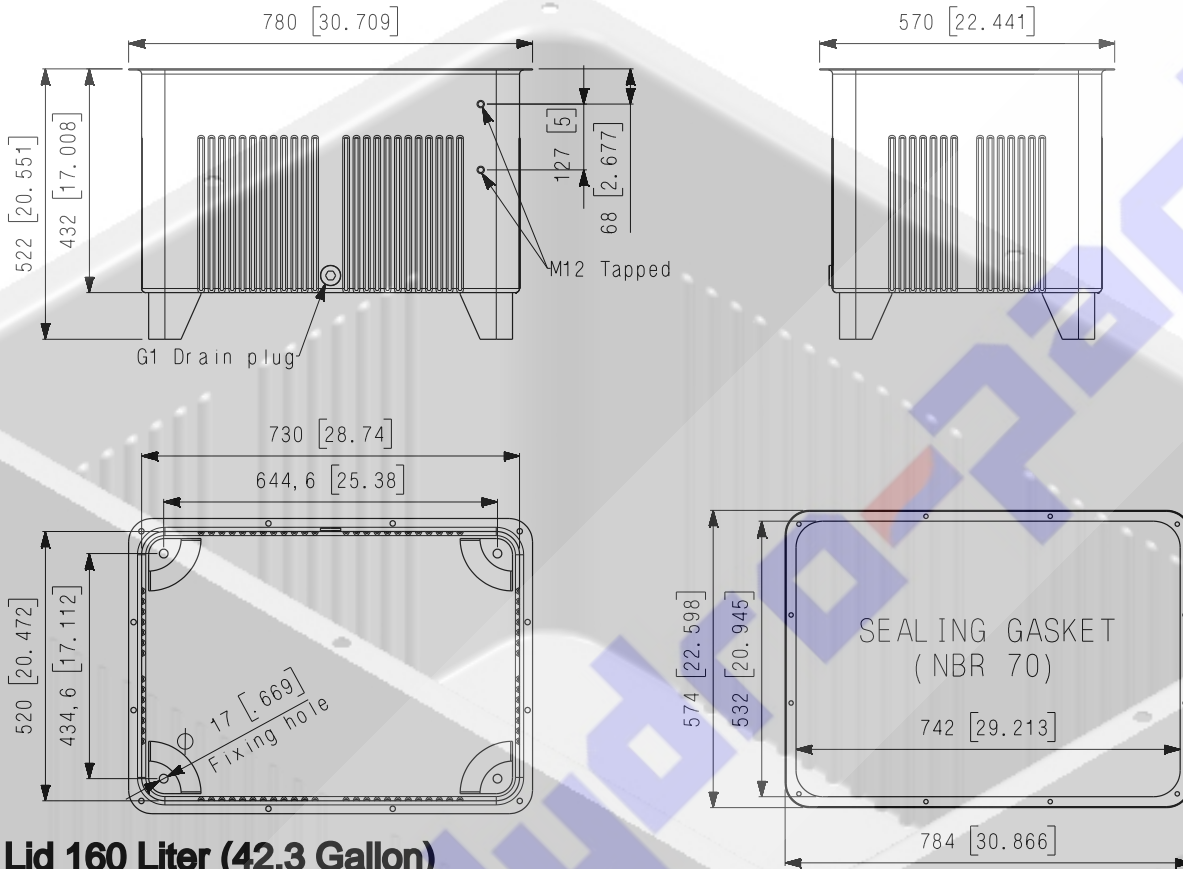

Lid 160 Liter (42,3 Gallon)

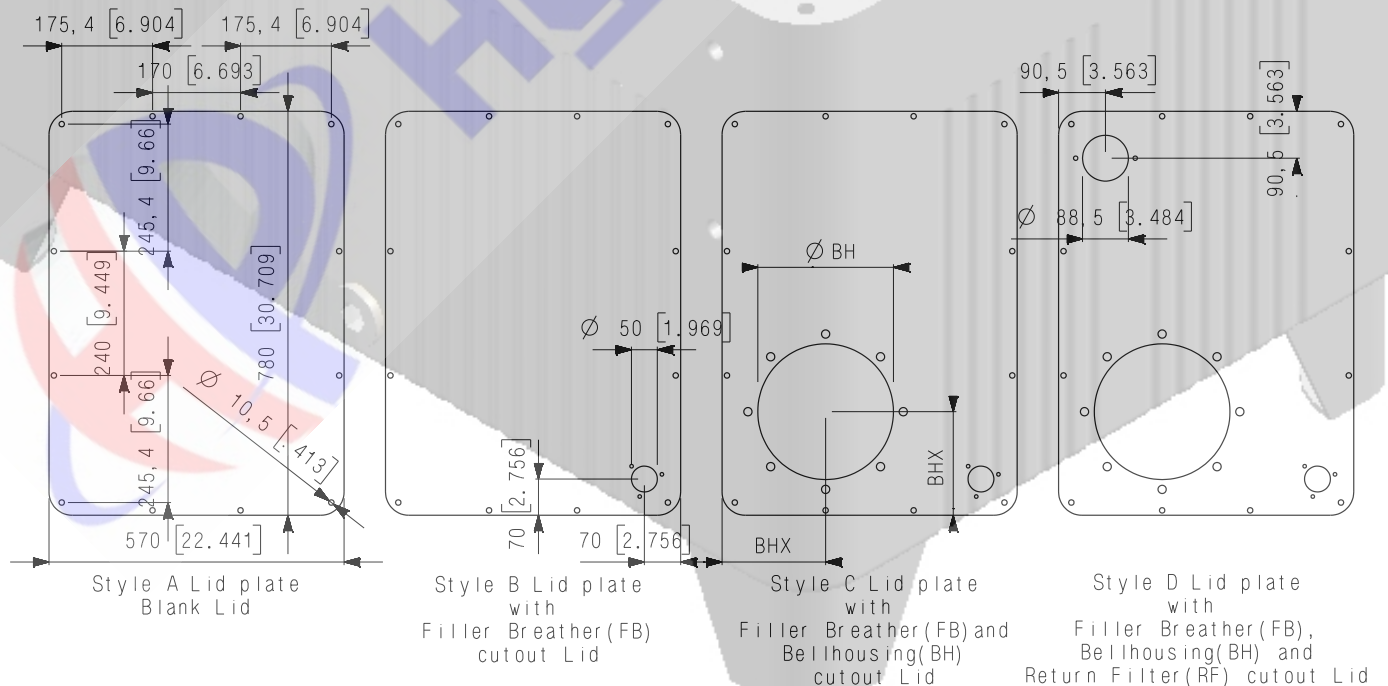

Weldless Steel Tank 250 Liter Type A (66,0 Gallon)

mm [in]

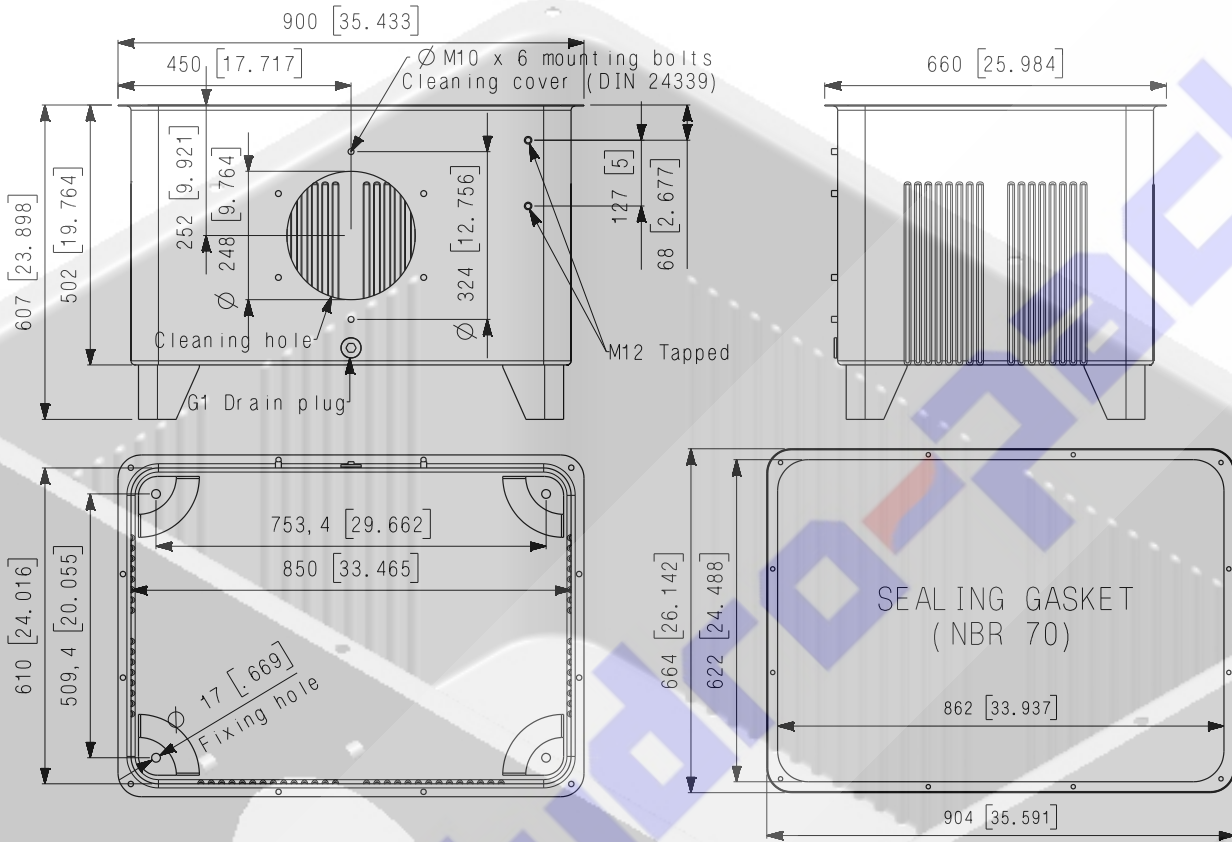

Lid 250 Liter (66,0 Gallon)

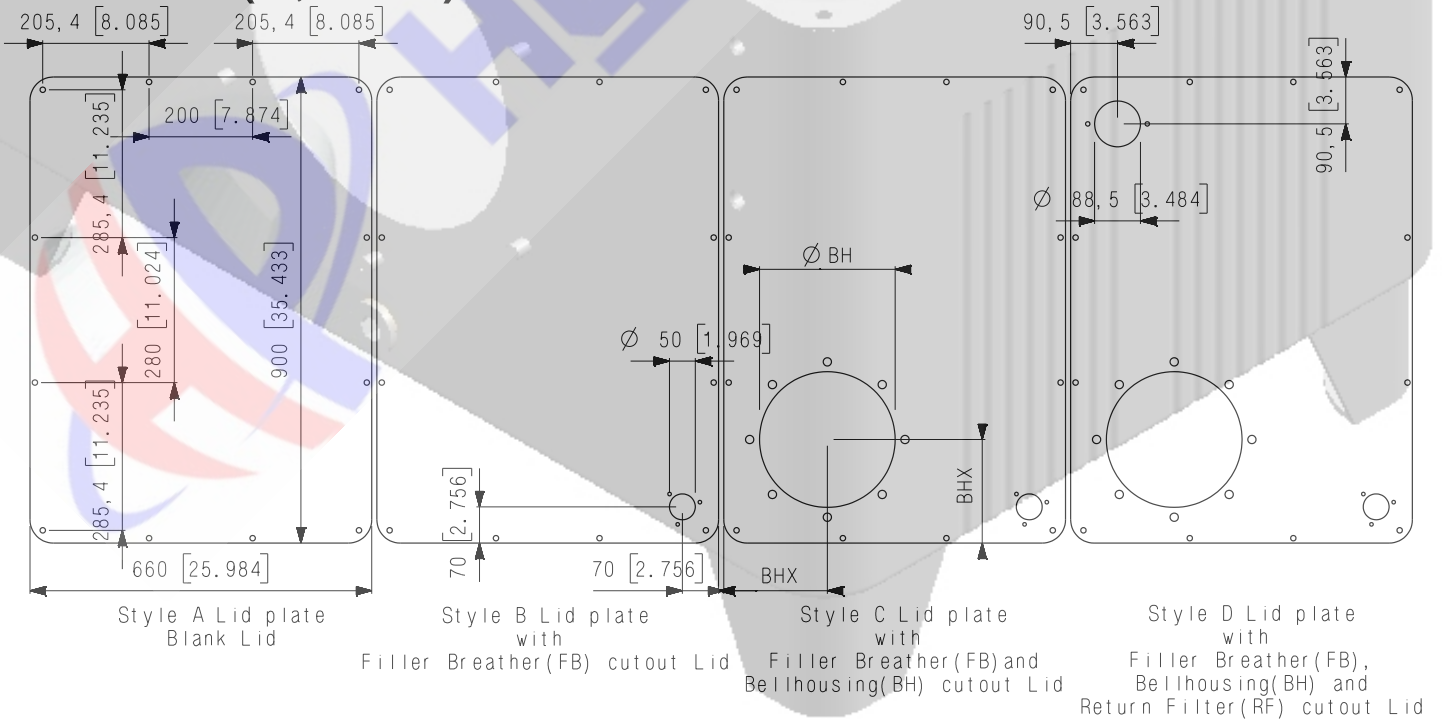

Weldless Steel Tank 250 Liter Type B (66,0 Gallon)

mm [in]

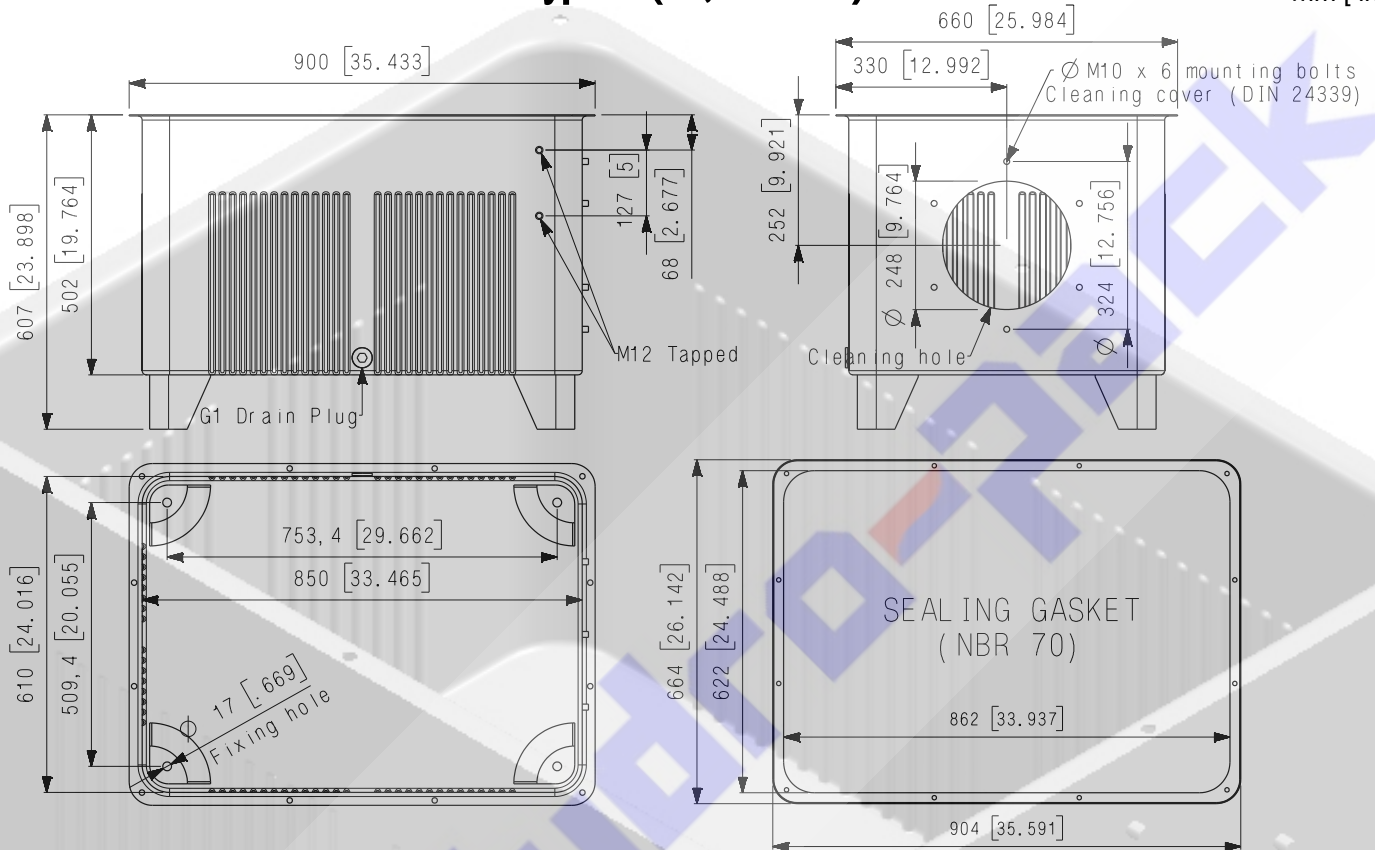

Lid 250 Liter (66,0 Gallon)

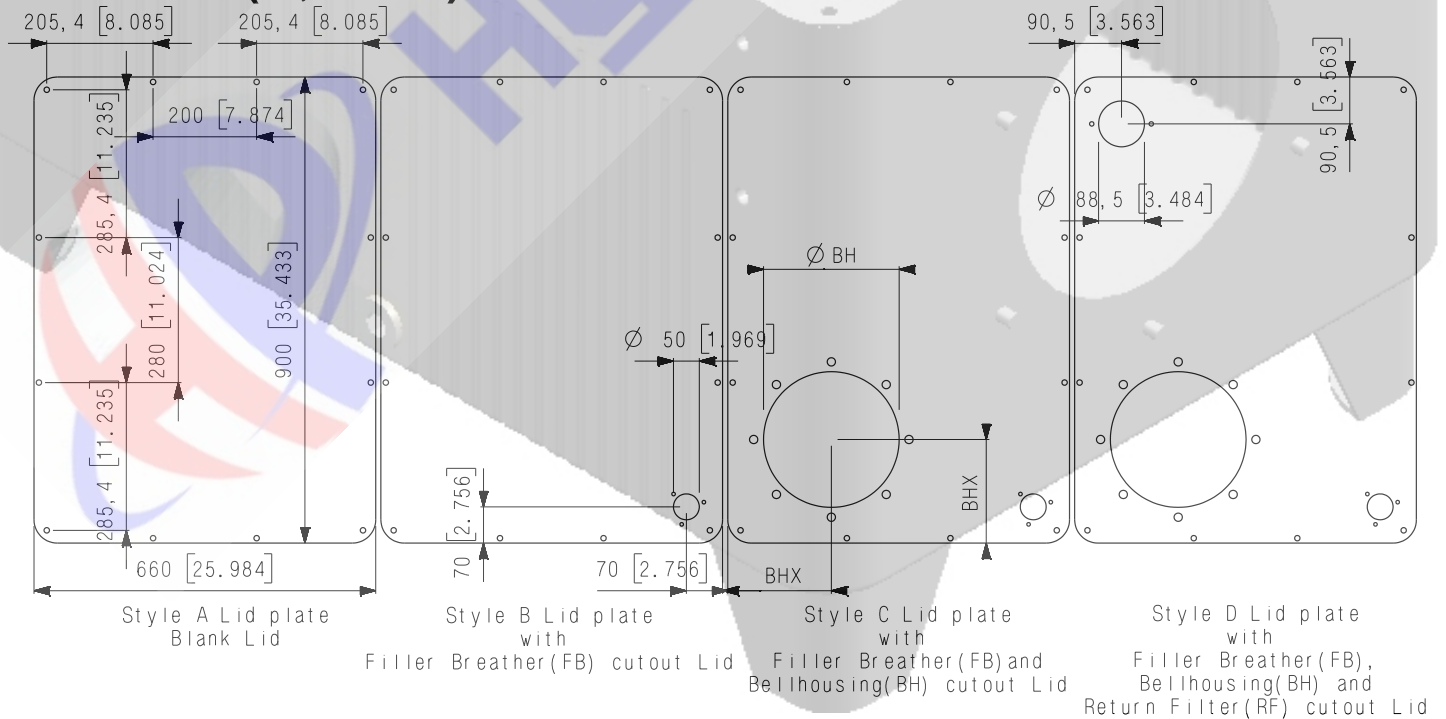

Weldless Steel Tank 250 Liter Type C (66,0 Gallon)

mm [in]

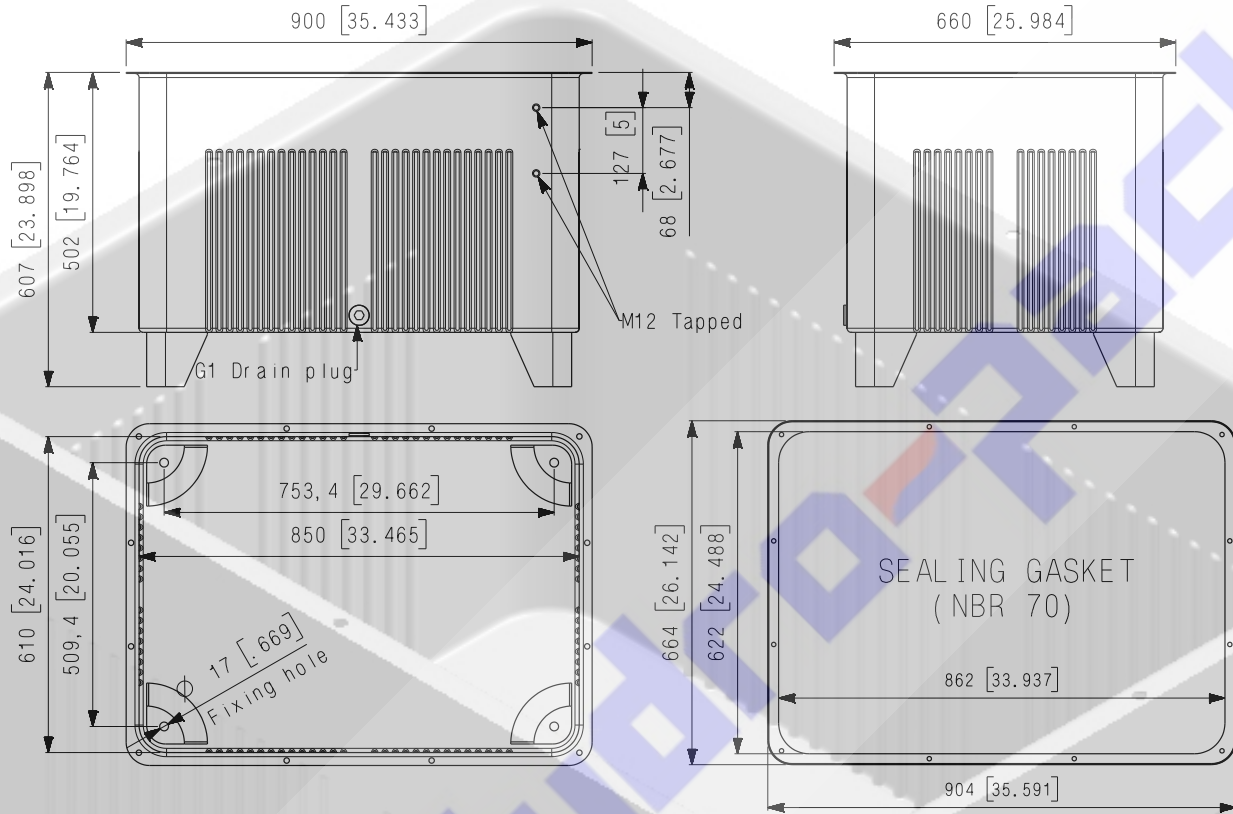

Lid 250 Liter (66,0 Gallon)

