

未注公差/General tolerances(mm)											0.1/10 ±2'			
0 ~ 3	>3 ~ 6	>6 ~ 10	>10 ~ 18	>18 ~ 30	>30 ~ 50	>50 ~ 80	>80 ~ 120	>120 ~ 180	>180 ~ 250	>250 ~ 315		>315 ~ 400	>400 ~ 500	>500
±0.12	±0.18	±0.22	±0.26	±0.31	±0.37	±0.57	±0.80	±0.93	±1.05	±1.15	±1.60	±2.20	±2.50	

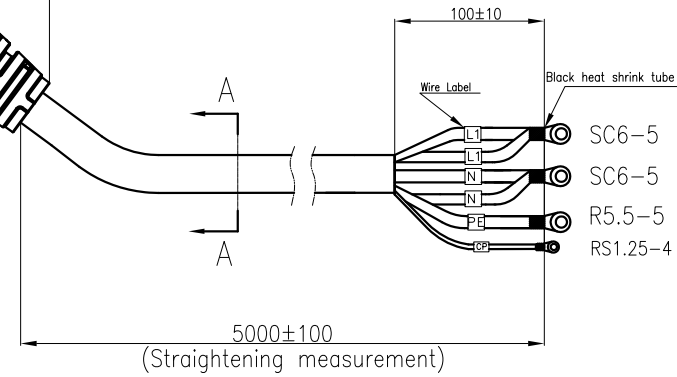

Wiring diagram

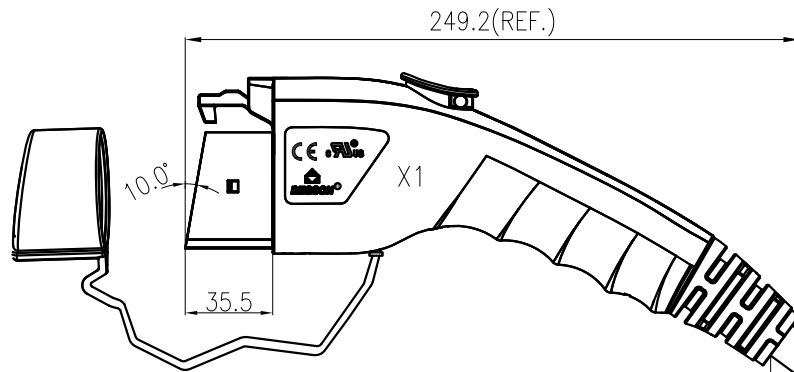
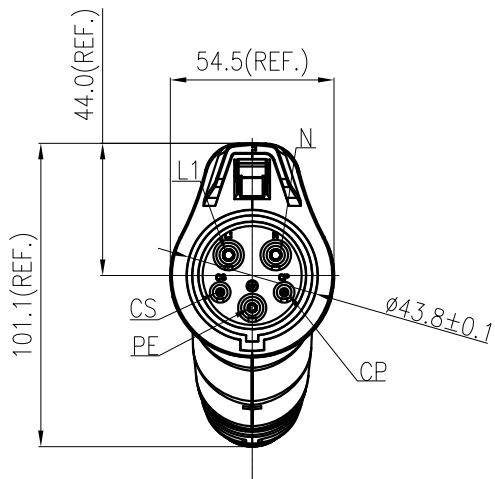
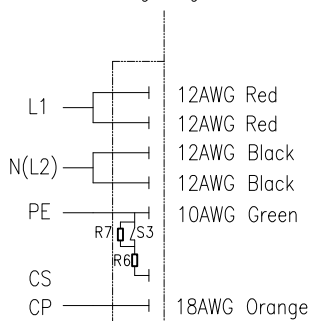

R6 = 150Ω ± 3%
R7 = 330Ω ± 3%

X1 Laser Printing Front Note:

Laser Printing Back Note(Arial):
MAAC-S-040A-V1-03-5.0M-86AH
40A 240V AC
SAE J1772:2017
Type 3R
20xxxxxx-xxxx

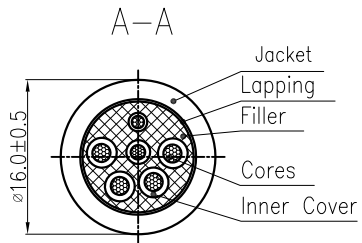

额定电压/Rated voltage	240V AC/40A
绝缘电阻/Insulation resistance	>100MΩ, 500V DC 1min
耐压/Withstanding voltage	L, N and PE ,2500V AC 1min
	L and N ,2500V AC 1min
防护等级/Ingress protection	Type 3R
插拔寿命/Insertion/Pullout times	10,000 Times
插拔力/Insertion/Pullout force	<75N
使用温度范围/Operating temperature(°C)	-30~+50
线材规格/Cable specification	4*12AWG+1*10AWG+1*18AWG
标准/Reference standard	Black SAE J1772:2017
符合RoHS环保要求/Conform to RoHS	Yes

	MATERIAL:	SURFACE/COLOR:
	MAT NO./REV: DO-1	MAT STATUS:
APPD: [Signature]	NAME MAAC-S-040A-V1-03-5.0M-86A(H)	
CHKD: [Signature]	DRAWING NO.	TYPE CUSTOMER DRAWING
DRAFT: HU MY 2023.07.05	DRAWING STATUS	SCALE 1:3
		SHEET 1/1

REV	ECN	DESCRIPTION	DRFT	DATE

Transfer or duplication of this document as well as the utilization or common practice of its contents are prohibited unless authorized in writing. All rights reserved for patent, copyright, trademark or design registrations. 未经授权，不得复制或在本文件中内容。保留所有权利。本公司保留对专利、商标、版权、设计注册或设计注册的所有权利。