

# **Speed Dome & PTZ Camera Installation Manual**



V1.0.4

# Foreword

## General





This manual introduces the precautions, installation preparations and cables of the Speed Dome & PTZ Camera (hereinafter referred to as "the Device").



Some specifications and metrics might not apply to all models.

## Safety Instructions

The following signal words might appear in the manual.

Signal Words	Meaning
 <b>DANGER</b>	Indicates a high potential hazard which, if not avoided, will result in death or serious injury.
 <b>WARNING</b>	Indicates a medium or low potential hazard which, if not avoided, could result in slight or moderate injury.
 <b>CAUTION</b>	Indicates a potential risk which, if not avoided, could result in property damage, data loss, reductions in performance, or unpredictable results.
 <b>TIPS</b>	Provides methods to help you solve a problem or save you time.
 <b>NOTE</b>	Provides additional information as a supplement to the text.

## Revision History

Revision Content	Revision Content	Release Time
V1.0.4	Updated the cover.	May 2024
V1.0.3	Updated Important Safeguards and Warnings.	December 2023
V1.0.2	Updated cable diameter and transmission distance.	July 2023
V1.0.1	<ul style="list-style-type: none"><li>• Updated foreword.</li><li>• Updated installation check chapter.</li></ul>	October 2021
V1.0.0	First release.	July 2020

## Privacy Protection Notice

As the device user or data controller, you might collect the personal data of others such as their face, audio, fingerprints, and license plate number. You need to be in compliance with your local privacy protection laws and regulations to protect the legitimate rights and interests of other people by implementing measures which include but are not limited: Providing clear and visible

identification to inform people of the existence of the surveillance area and provide required contact information.

## Interface Declaration

This manual mainly introduces the relevant functions of the device. The interfaces used in its manufacture, the procedures for returning the device to the factory for inspection and for locating its faults are not described in this manual. Please contact technical support if you need information on these interfaces.

## About the Manual

- The manual is for reference only. Slight differences might be found between the manual and the product.
- We are not liable for losses incurred due to operating the product in ways that are not in compliance with the manual.
- The manual will be updated according to the latest laws and regulations of related jurisdictions. For detailed information, see the paper user's manual, use our CD-ROM, scan the QR code or visit our official website. The manual is for reference only. Slight differences might be found between the electronic version and the paper version.
- All designs and software are subject to change without prior written notice. Product updates might result in some differences appearing between the actual product and the manual. Please contact customer service for the latest program and supplementary documentation.
- There might be errors in the print or deviations in the description of the functions, operations and technical data. If there is any doubt or dispute, we reserve the right of final explanation.
- Upgrade the reader software or try other mainstream reader software if the manual (in PDF format) cannot be opened.
- All trademarks, registered trademarks and company names in the manual are properties of their respective owners.
- Please visit our website, contact the supplier or customer service if any problems occur while using the device.
- If there is any uncertainty or controversy, we reserve the right of final explanation.

# Important Safeguards and Warnings

This section introduces content covering the proper handling of the Device, hazard prevention, and prevention of property damage. Read carefully before using the Device, and comply with the guidelines when using it.

## Transportation Requirements



- Do not place heavy stress on the Device, violently vibrate or immerse it in liquid during transportation.
- The complete package is necessary for transportation. Please keep the packing box safe. Whether it is delivered by the contractor or returned to the factory for repair, we will assume no responsibility for any damage or problems caused during transportation due to the incomplete package being sent.

## Storage Requirements



Do not place heavy stress on the Device, violently vibrate or immerse it in liquid during storage.

## Installation Requirements



- Make sure that the power is off when you connect the cables, install or disassemble the Device.
- All installation and operations must conform to the local electrical safety code and standards.
- Buckle the safety hook before installing the Device if it is included.



- Please follow the electrical requirements to power the Device.
  - ◇ Following are the requirements for selecting a power adapter.
    - The power supply must conform to the requirements of IEC 60950-1 and IEC 62368-1 standards.
    - The voltage must meet the SELV (Safety Extra Low Voltage) requirements and not exceed ES-1 standards.
    - When the power of the Device does not exceed 100 W, the power supply must meet LPS requirements and be no higher than PS2.
  - ◇ We recommend using the power adapter provided with the Device.
  - ◇ When selecting the power adapter, the power supply requirements (such as rated voltage) are subject to the Device label.
- For devices that support lasers, do not aim the laser directly at eyes. And keep it a proper distance away from flammables to avoid the risk of fire.



- The Device must be installed in a location that only professionals can access.
- When installing the Device, make sure that the converter is installed inside the bracket.
- To avoid damage, keep the Device away from televisions, radio transmitters, electromagnetic devices, electric machines, transformers, and speakers. Do not install it in places with smoke or vapor, high temperature, and lots of dust. Do not install the device near a heating furnace and other heat sources, such as a spotlight, kitchen, and boiler room.
- Prevent the Device from falling down and from being exposed to violent vibrations.
- We recommend you use the Device with a lightning surge protector for stronger protection against lightning. For outdoor scenarios, strictly comply with the lightning protection regulations.
- Before installing the Device, confirm the salt spray tolerance level corresponding to its model. Do not install the Device in an environment with higher salt spray levels than it can tolerate. There are three salt spray tolerance levels for the Device.
  - ◇ Devices with high salt spray tolerance levels can be installed in areas that are within 1500 meters of the sea, or on an offshore platform.
  - ◇ Devices with medium salt spray tolerance levels can be installed in areas that is 1500 meters away from the sea.
  - ◇ Devices that do not have salt spray tolerance can only be installed in areas that are 3000 meters away from the sea.
- The installer of the Device must have required certification or qualified training for installing closed-circuit television (CCTV) systems. They must also be trained and certified to work at heights, and must have knowledge and skills in the following areas:
  - ◇ Basic knowledge and skills in installing CCTV systems and components.
  - ◇ Basic knowledge and skills in low-voltage wiring and in connecting low-voltage electronic circuits.
  - ◇ The ability to read and understand the manual.
- Requirements for lifting the Device:
  - ◇ The device lifting equipment must be able to adapt to the installation site and the installer must have knowledge of the installation method.
  - ◇ The device lifting equipment must reach the installation height.
  - ◇ The device lifting equipment must have a high safety rating.

## Operation Requirements



### ● Battery Pack Precautions

Preventive measures (including but not limited to):

- ◇ Do not transport, store or use the batteries in high altitudes with low pressure and environments with extremely high and low temperatures.
- ◇ Do not dispose the batteries in fire or a hot oven, or mechanically crush or cut the batteries to avoid an explosion.
- ◇ Do not leave the batteries in environments with extremely high temperatures to avoid explosions and leakage of flammable liquid or gas.
- ◇ Do not subject the batteries to extremely low air pressure to avoid explosions and the leakage of flammable liquid or gas.
- Do not connect multiple devices to the same power adapter to avoid the risk of overheating or fire if the rated load is exceeded. Please use the power adapter provided by the manufacturer.
- The illuminators of some devices emit a blue light that is hazardous to eyes. Do not look directly at the light source to avoid damaging your eyes.



#### WARNING

- Operating the Device in a domestic environment may cause radio interference.
- Immediately cut the power and disconnect the power cord if smoke, noise or a disgusting smell comes from the the Device. Make sure to contact your local retailer or after-sales service.
- Place the Device in a location that children cannot easily access.



- Make sure there are no foreign metal objects or flammables in the Device. Foreign objects inside the Device might cause fire, short-circuits and damage to the Device. Carefully protect the Device from rain and sea water. Power off the Device and disconnect the power cord immediately if water or other liquids flow into it, and contact after-sales service.
- Do not aim the lens at intense light sources, including sunlight and incandescent light to avoid the lens becoming damaged.
- After unpacking, even if the packing bag is damaged or leaking air, and the desiccant particles are different colors, the normal use of the Device will not be affected.
- We are not liable for any problems caused by the incorrect use of the Device.
- We are not liable for any problems caused by overuse of certain components.

## Maintenance Requirements



#### DANGER

Replacing unwanted batteries with the wrong type of new batteries might result in explosion.

Preventive measures (including but not limited to):

- Replace unwanted batteries with new batteries of the same type and model to avoid the risk of fire and explosion.
- Dispose of the old batteries as instructed.



- Cut off the power and consult after-sale service before maintenance.
- Clean the casing with a soft cloth. To remove the dirt, dip the soft cloth in detergent, wring it out to wipe away the dirt. Dry the casing with a dry soft cloth. Do not use gasoline, paint thinner, or other chemicals to clean the casing, and avoid long time contact between the plastic or rubber material and the casing. This is to avoid the casing becoming deformed and paint flaking.
- Contact your local dealer or the service center nearest to you if the Device needs internal configuration or maintenance. Do not dismantle or modify the Device without a qualified professional present to avoid the risk of danger or damage to the Device. We will assume no responsibility for any problems caused by unauthorized modifications or maintenance.
- All maintenance personnel of the Device must have required certification or qualified training for performing maintenance on closed-circuit television (CCTV) systems. They must also be trained and certified to work at heights, and must have knowledge and skills in the following areas:
  - ◇ Basic knowledge and skills in installing CCTV systems and components.
  - ◇ Basic knowledge and skills in low-voltage wiring and in connecting low-voltage electronic circuits.
  - ◇ The ability to read and understand the manual.

# Table of Contents

Foreword.....	I
Important Safeguards and Warnings.....	III
1 Installation Preparation.....	1
1.1 Basic Requirements.....	1
1.2 Installation Check.....	1
1.3 Cable Preparation.....	1
1.3.1 Video Cable Requirements.....	1
1.3.2 RS-485 Cable Requirements.....	2
1.3.3 Selecting Power Cable.....	2
2 Cables.....	3
2.1 Cable Description.....	3
2.2 Cable Connection.....	4
2.2.1 Alarm Cable Connection.....	4
2.2.2 Thunder-Proof Cable Connection.....	5
3 RS-485 Cable.....	9
3.1 Basic Features.....	9
3.2 Common Issues in Use.....	9
3.3 FAQ on RS-485 Cable.....	10
4 Wi-Fi Performance.....	11
5 Cable Diameter (24 VAC) and Transmission Distance.....	12
6 Cable Diameter (12 VDC) and Transmission Distance.....	13
7 Cable Diameter (24 VDC) and Transmission Distance.....	14
8 Cable Diameter (36 VDC) and Transmission Distance.....	15
9 Cable Diameter (48 VDC) and Transmission Distance.....	17
10 Wire Gauge Reference Sheet.....	19

# 1 Installation Preparation

## 1.1 Basic Requirements

- All installation and operations shall conform to your local electrical safety regulations, fire protection regulations, and other relevant regulations.
- Make sure that the application scenario conforms to installation requirements. Contact your local retailer or customer service center if there is any problem.
- Use the Device according to the operating environment.
- Keep the original packing material well because you might need it to pack the Device and send it back for repair.

## 1.2 Installation Check

- Make sure that the place where the Device is installed has enough space to hold the Device and its mounting accessories.
- For PTZ cameras, make sure that the place where the Device is installed can sustain at least 4 times the weight of the Device and its mounting accessories; for speed domes, make sure that the ceiling and wall can sustain 8 times the weight of the Device and its mounting accessories.
- Do not install the Device at risky or unstable places.
- Make sure that the wall is thick enough to install expansion bolts (Users need to buy expansion bolts separately).
- For speed domes support intelligent tracking, illegal parking capture or laser, make sure that the mounting height is over 6 m.
- For laser PTZ, make sure that the mounting height is over 10 m.
- Support wall mount and plane mount, fixed with M8 × 25 hex flange assembling bolts.

## 1.3 Cable Preparation

Select the video cable depending on transmission distance.

### 1.3.1 Video Cable Requirements

- 75 ohm.
- Pure copper cored cables.
- 95% braided copper shielding.

Table 1-1 Cables and maximum transmission distance (network)

Model	Maximum Transmission Distance (ft/m)
RG59/U	750 ft/229 m
RG6/U	1,000 ft/305 m
RG11/U	1,500 ft/457 m

Table 1-2 Cables and maximum transmission distance (HDCVI)

Model	Maximum Transmission Distance (ft/m)
SYV-75-3	720P (25 fps/30 fps): 1,640 ft/500 m
	720P (50 fps/60 fps): 984 ft/300 m
	1080P (25 fps/30 fps): 984 ft/300 m

## 1.3.2 RS-485 Cable Requirements

When using 0.56 mm (24 AWG) twisted-pair line, depending on different baud rates, the theoretical maximum transmission distance is different.

Table 1-3 Theoretical maximum transmission distance

Baud Rate	Maximum Transmission Distance
2400 bps	1800 m
4800 bps	1200 m
9600 bps	800 m

The maximum transmission distance will be reduced in the following conditions: When thinner communication cables are used; the Device is used in places with intense electromagnetic interference; too many devices are connected to the RS-485 cable. Otherwise, maximum transmission distance will be increased.

## 1.3.3 Selecting Power Cable

### 1.3.3.1 Power Cable

Depending on the power cable specification, the same cable diameter corresponds to different transmission distance.

### 1.3.3.2 PoE Power Cable

Table 1-4 PoE power cable

POE Specification	Network Cable Specification
AF	CAT5E and network cables with higher standard.
AT	
HiPoE or BT	

# 2 Cables

## 2.1 Cable Description

The Device is equipped with a multi-functional combination cable by default, including power cord, video cable, audio cable, RS-485 control cable, alarm cable, network cable, and optical fiber cable.



Cables might be different depending on the model. The manual will introduce the cables as complete as possible.

Figure 2-1 Cables

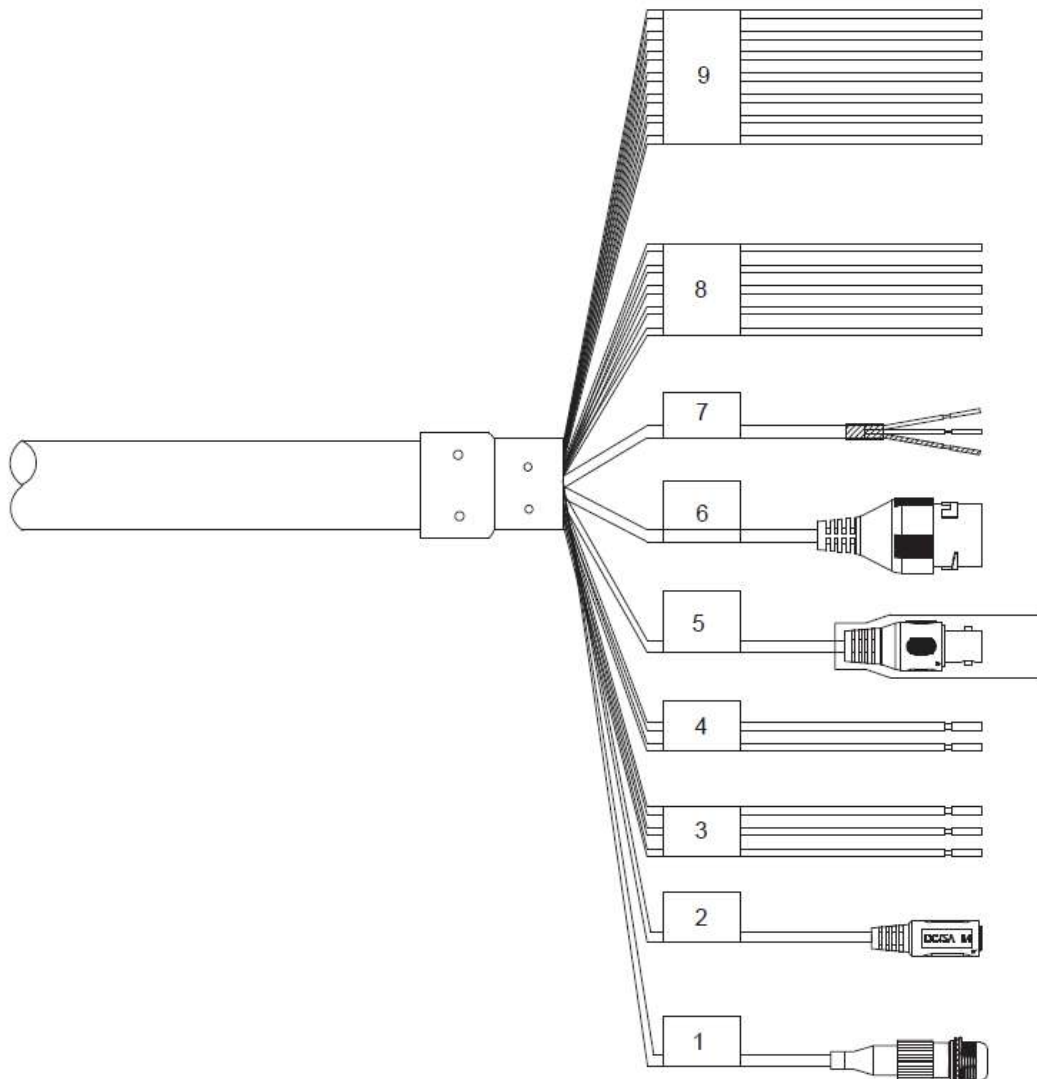

Table 2-1 Cable description

No.	Description
1	FC connector

No.	Description
2	DC power input port
3	24 VAC power input <ul style="list-style-type: none"> <li>● Red: V+</li> <li>● Black: V-</li> <li>● Yellow-green: Grounding cable</li> </ul>
4	RS-485 <ul style="list-style-type: none"> <li>● Yellow: A+</li> <li>● Orange: B-</li> </ul>
5	Video output port
6	Ethernet port
7	<ul style="list-style-type: none"> <li>● White: Audio input</li> <li>● Red: Audio output</li> <li>● Black: Audio grounding cable</li> </ul>
8	<ul style="list-style-type: none"> <li>● Blue: Alarm output 1</li> <li>● Black: Alarm output 2</li> <li>● Green: Contact switch 1</li> <li>● Pink: Contact switch 2</li> <li>● Yellow-green: Grounding cable</li> </ul>
9	<ul style="list-style-type: none"> <li>● Red: Alarm input 1</li> <li>● Brown: Alarm input 2</li> <li>● Grey: Alarm input 3</li> <li>● Light green: Alarm input 4</li> <li>● Purple: Alarm input 5</li> <li>● White: Alarm input 6</li> <li>● Yellow-black: Alarm input 7</li> </ul>

## 2.2 Cable Connection

### 2.2.1 Alarm Cable Connection

#### Procedure

- Step 1 Connect the alarm input device to ALARM\_IN and ALARM\_GND of the user cable.
- Step 2 Connect alarm output device to ALARM\_OUT and ALARM\_COM of the user cable, and alarm output is relay switch output.
- Step 3 Go to the web page of the Device, and complete settings for alarm input and output devices. The alarm input on web page corresponds to the alarm input of the cables. Set the corresponding NO and NC output according to the high/low level signal generated by alarm input device when alarm is triggered.
- Step 4 Set the alarm output of cables on the web page.

## 2.2.2 Thunder-Proof Cable Connection



The following installation figures are for reference only, and the operation might be different depending on the products. This chapter uses PTZ camera as an example.

### 2.2.2.1 Outdoor

Transient voltage suppressor (TVS) is applied to protect the Device against voltage spikes and overvoltage below 6000V. However, it is still necessary to do operations to protect the Device according to actual conditions.

- The signal transmission cable must stay at least 50 m away from high voltage devices and high voltage wires.
- When laying cables outdoors, try to lay them under the eaves.
- At open places, lay cables underground by means of hermetic steel tube, and then do equipotential grounding to both ends of steel tubes. Laying overhead power cables are prohibited.
- At places with severe thunderstorms and induced voltage (like substation), you need to prepare high-powered lightning protection devices and lightning conductors.
- When laying cables and connecting lightning protection devices, you must comply with regional laws and regulations.
- You must do equipotential grounding to the electric system. The grounding device must meet the requirements of anti-jamming and conform to your local electrical safety code. The grounding device shall not form short circuit to N (neutral) line of high voltage power grid or be mixed with other wires. When the electrical system is connected to the ground cable, the impedance cannot exceed  $4\Omega$  and the cross-sectional area of the earth lead cannot exceed  $25\text{ mm}^2$ .

Figure 2-2 Installing lightning protection devices outdoors (1)

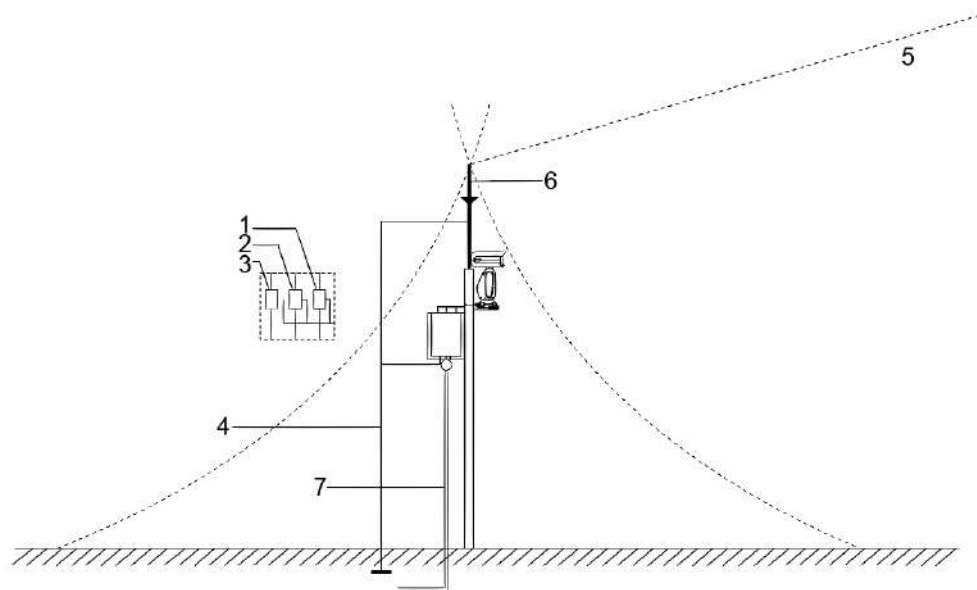
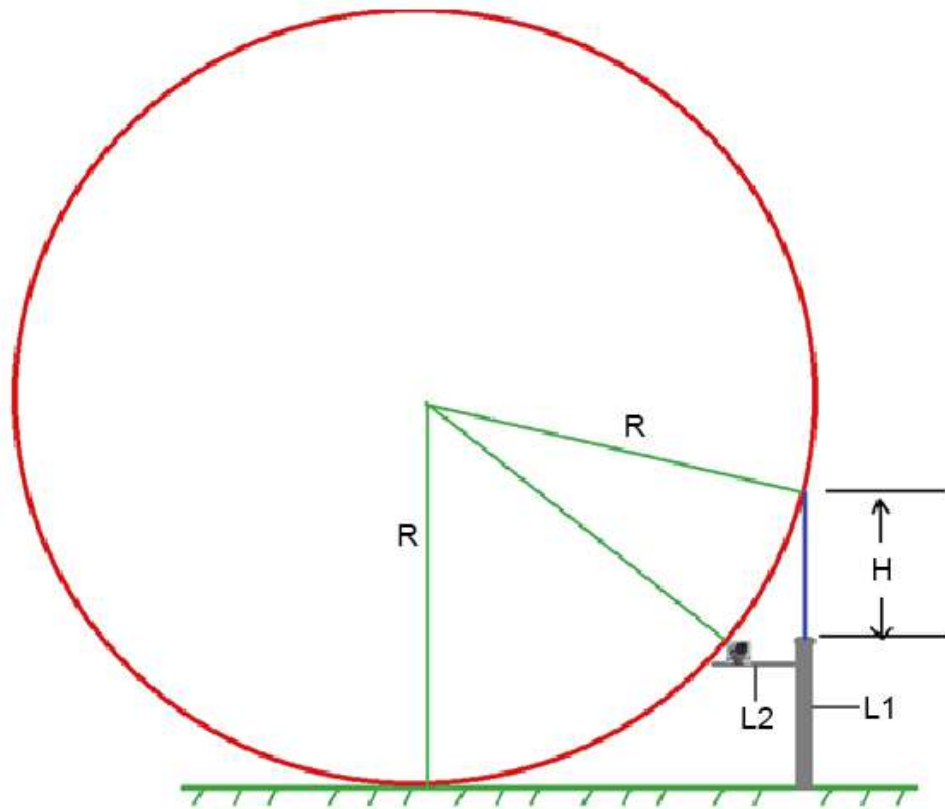

Table 2-2 Installing lightning protection devices outdoors

No.	Description
1	Video lightning conductor.
2	Communication lightning conductor.
3	Power supply lightning conductor.
4	Impedance of the cable connected to the grounding wire should be less than 4 Ω.
5	The radius is 60 m.
6	Lightning conductor.
7	Steel tube.

Figure 2-3 Installing lightning protection devices outdoors (2)



- R: The radius of the circle, and R = 60 m.
- L1: The length of the pole that holds the lightning conductor.
- L2: The length of the rail that holds the Device.
- H: The length of the lightning conductor.

To get the value of L1, you need to use the formula:

$$\left(\sqrt{R^2 - [R - (L1 + H)]^2} - L2\right)^2 + (R - L1)^2 = R^2$$

### 2.2.2.2 Indoor

You can use multiple copper cables whose cross-sectional area is not less than 25 mm<sup>2</sup> to connect the yellow-green grounding cable/grounding screws to the indoor equipotential grounding terminals.

Figure 2-4 Installing lightning protection devices indoors

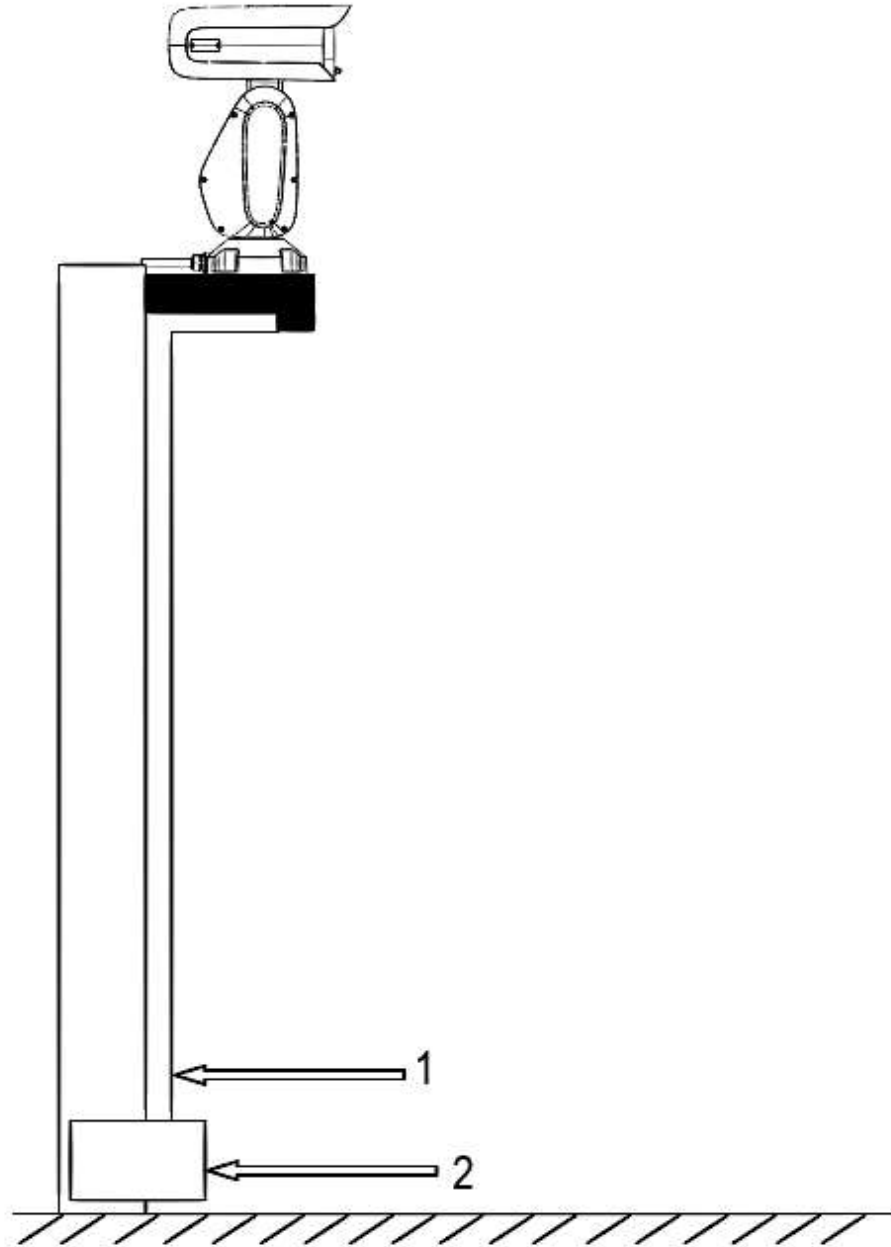

Table 2-3 Installing lightning protection devices indoors

No.	Name
1	Yellow-green grounding cable

No.	Name
2	Indoor equipotential grounding terminal

# 3 RS-485 Cable

## 3.1 Basic Features

RS-485 industrial buses are half-duplex communication buses whose characteristic impedance is 120 Ω. Its maximum load is 32 payloads (including controller devices and controlled devices).

## 3.2 Common Issues in Use

Users tend to connect devices as the way displayed in Figure 3-1 . In this case, the terminal resistance must be connected to the two devices whose cable length is the longest among all the devices (see Figure 3-1 , cable length between 1# and 15# is the longest). However, this connection manner does not comply with the RS-485 industrial standard. As a result, common issues like signal reflection and anti-interference capability reduction will occur. And the Device is out of control or cannot stop.

Figure 3-1 Common method to connect devices

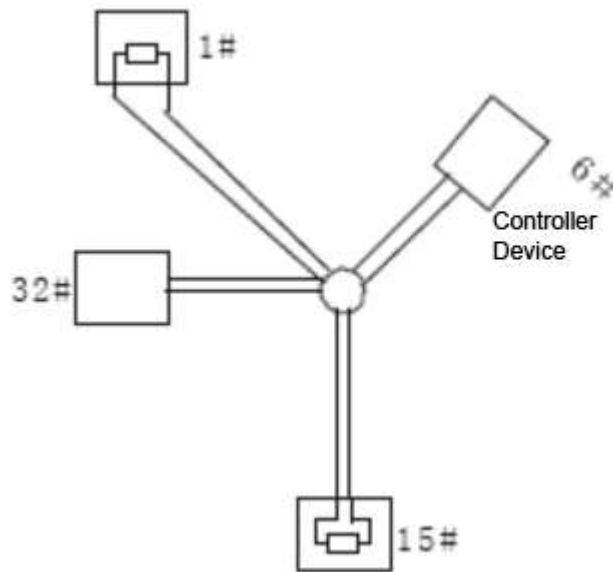

To fix the issues, it is recommended to use RS-485 distributors. The RS-485 distributor can help avoid the common connection issues so as to improve transmission quality.

Figure 3-2 Connecting method with RS-485 distributors

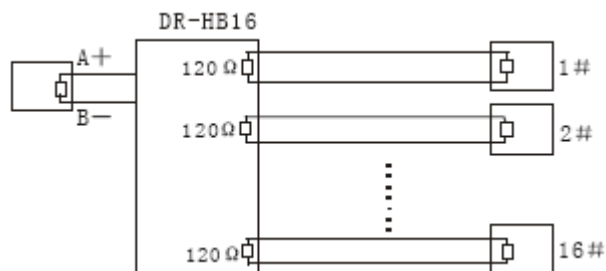

### 3.3 FAQ on RS-485 Cable

Malfunction	Possible Reason	Solution
The Device can perform self-check, but is out of control.	Baud rate/address of the host and Device are not matched.	Modify the baud rate/address of the host or Device to be matched.
	Positive electrode and negative electrode of RS-485 cable are misconnected.	Connect cables to the positive electrode and negative electrode correctly.
	Loose connection.	Connect the cables firmly.
	RS-485 cable is broken.	Replace RS-485 cable.
The Device can be controlled, but the operation is not smooth.	RS-485 cable is in poor contact.	Connect the RS-485 cable firmly.
	RS-485 cable is broken.	Replace RS-485 cable.
	The distance between the host and the Device is too long.	Install terminal resistance.
	Too many cameras are connected parallelly.	Install RS-485 distributors.

# 4 Wi-Fi Performance

Table 4-1 Wi-Fi performance description

Performance	Description	
Frequency band supported	2.4 G; 5 G	
Working channel (consistent with AP)	2.4 G	CH1–CH13 (The working channel might be different depending on the model).
	5 G	The working channel might be different depending on the model.
Transmission performance	<ul style="list-style-type: none"> <li>At open places without interference, if the Device is installed at least 1.5 m above the ground, the effective communication distance is 100 m.</li> <li>In the environment without interference, the signal can pass through a load-bearing wall, and the effective communication distance is 20 m.</li> </ul>  <p>The actual wall penetration capacity is greatly affected by network layout and actual environment.</p>	

# 5 Cable Diameter (24 VAC) and Transmission Distance

The recommended transmission distances are for reference only, and the actual conditions shall prevail. The following table shows the maximum transmission distance of cables with certain diameter when the 24 VAC power source voltage loss rate is below 10%.

For devices powered by alternating current, the maximum voltage loss rate allowed is 10%.



In the following table, the unit for diameter is mm, and the unit for transmission distance is foot (m).

Table 5-1 Cable diameter (24 VAC) and transmission distance

Transmission Power (W)	Transmission Distance (Diameter: 0.80)	Transmission Distance (Diameter: 1.00)	Transmission Distance (Diameter: 1.25)	Transmission Distance (Diameter: 2.00)
5	391 (119)	611 (186)	954 (291)	2443 (745)
10	195 (60)	305 (93)	477 (145)	1221 (372)
15	130 (40)	204 (62)	318 (97)	814 (248)
20	98 (30)	153 (47)	239 (73)	611 (186)
25	78 (24)	122 (37)	191 (58)	489 (149)
30	65 (20)	102 (31)	159 (48)	407 (124)
35	56 (17)	87 (27)	136 (42)	349 (106)
40	49 (15)	76 (23)	119 (36)	305 (93)
45	43 (13)	68(21)	106(32)	271 (83)
50	39 (12)	61 (19)	95 (29)	244 (74)
55	36 (11)	56 (17)	87 (26)	222 (68)
60	33 (10)	51 (16)	80 (24)	204 (62)
65	30 (9)	47 (14)	73 (22)	188 (57)
70	28 (9)	44 (13)	68 (21)	174 (53)
75	26 (8)	41 (12)	64 (19)	163 (50)
80	24 (7)	38 (12)	60 (18)	153 (47)
85	23 (7)	36 (11)	56 (17)	144 (44)
90	22 (7)	34 (10)	53 (16)	136 (41)
95	21 (6)	32 (10)	50 (15)	129 (39)
100	20 (6)	31 (9)	48 (15)	122 (37)

## 6 Cable Diameter (12 VDC) and Transmission Distance

The recommended transmission distances are for reference only, and the actual conditions shall prevail. The following table shows the maximum transmission distance of cables with certain diameter when the 12 VDC power source voltage loss rate is below 10%.

For devices powered by direct current, the maximum voltage loss rate allowed is 10%. The cables mentioned in the following table are all copper cables with electrical resistivity  $\rho=0.0175 \Omega \times \text{mm}^2/\text{m}$ .



In the following table, the unit for diameter is mm, and the unit for transmission distance is foot (m).

Table 6-1 Cable diameter (12 VDC) and transmission distance

Transmission Power (W)	Transmission Distance (Diameter: 0.80)	Transmission Distance (Diameter: 1.00)	Transmission Distance (Diameter: 1.25)	Transmission Distance (Diameter: 2.00)
5	98 (30)	153 (47)	239 (73)	611 (186)
10	49 (15)	76 (23)	119 (36)	305 (93)
15	33 (10)	51 (16)	80 (24)	204 (62)
20	24 (7)	38 (12)	60 (18)	153 (47)
25	20 (6)	31 (9)	48 (15)	122 (37)
30	16 (5)	25 (8)	40 (12)	102 (31)
35	14 (4)	22 (7)	34 (10)	87 (27)
40	12 (4)	19 (6)	30 (9)	76 (23)
45	11 (3)	17 (5)	27 (8)	68 (21)
50	10 (3)	15 (5)	24 (7)	61 (19)
55	9 (3)	14 (4)	22 (7)	56 (17)
60	8 (2)	13 (4)	20 (6)	51 (16)
65	8 (2)	12 (4)	18 (6)	47 (14)
70	7 (2)	11 (3)	17 (5)	44 (13)
75	7 (2)	10 (3)	16 (5)	41 (12)
80	6 (2)	10 (3)	15 (5)	38 (12)
85	6 (2)	9 (3)	14 (4)	36 (11)
90	5 (2)	8 (3)	13 (4)	34 (10)
95	5 (2)	8 (2)	13 (4)	32 (10)
100	5 (1)	8 (2)	12 (4)	31 (9)

# 7 Cable Diameter (24 VDC) and Transmission Distance

The recommended transmission distances are for reference only, and the actual conditions shall prevail. The following table shows the maximum transmission distance of cables with certain diameter when the 24 VDC power source voltage loss rate is below 10%.

For devices powered by direct current, the maximum voltage loss rate allowed is 10%. The cables mentioned in the following table are all copper cables with electrical resistivity  $\rho=0.0175 \Omega \times \text{mm}^2/\text{m}$ .



In the following table, the unit for diameter is mm, and the unit for transmission distance is foot (m).

Table 7-1 Cable diameter (24 VDC) and transmission distance

Transmission Power (W)	Transmission Distance (Diameter: 0.80)	Transmission Distance (Diameter: 1.00)	Transmission Distance (Diameter: 1.25)	Transmission Distance (Diameter: 2.00)
5	391 (119)	611 (186)	954 (291)	2443 (745)
10	195 (60)	305 (93)	477 (145)	1221 (372)
15	130 (40)	204 (62)	318 (97)	814 (248)
20	98 (30)	153 (47)	239 (73)	611 (186)
25	78 (24)	122 (37)	191 (58)	489 (149)
30	65 (20)	102 (31)	159 (48)	407 (124)
35	56 (17)	87 (27)	136 (42)	349 (106)
40	49 (15)	76 (23)	119 (36)	305 (93)
45	43 (13)	68 (21)	106 (32)	271 (83)
50	39 (12)	61 (19)	95 (29)	244 (74)
55	36 (11)	56 (17)	87 (26)	222 (68)
60	33 (10)	51 (16)	80 (24)	204 (62)
65	30 (9)	47 (14)	73 (22)	188 (57)
70	28 (9)	44 (13)	68 (21)	174 (53)
75	26 (8)	41 (12)	64 (19)	163 (50)
80	24 (7)	38 (12)	60 (18)	153 (47)
85	23 (7)	36 (11)	56 (17)	144 (44)
90	22 (7)	34 (10)	53 (16)	136 (41)
95	21 (6)	32 (10)	50 (15)	129 (39)
100	20 (6)	31 (9)	48 (15)	122 (37)

# 8 Cable Diameter (36 VDC) and Transmission Distance

The recommended transmission distances are for reference only, and the actual conditions shall prevail. The following table shows the maximum transmission distance of cables with certain diameter when the 36 VDC power source voltage loss rate is below 25%.

For devices powered by direct current, the maximum voltage loss rate allowed is 25%.



In the following table, the unit for diameter is mm, and the unit for transmission distance is foot (m).

Table 8-1 Cable diameter (36 VDC) and transmission distance

Transmission Power (W)	Transmission Distance (Diameter: 0.80)	Transmission Distance (Diameter: 1.00)	Transmission Distance (Diameter: 1.25)	Transmission Distance (Diameter: 2.00)
5	1832 (558)	2862 (872)	4473 (1363)	11450 (3490)
10	916 (279)	1431 (436)	2236 (682)	5725 (1745)
15	611 (186)	954 (291)	1491 (454)	3817 (1163)
20	458 (140)	716 (218)	1118 (341)	2862 (872)
25	366 (112)	572 (174)	895 (273)	2290 (698)
30	305 (93)	477 (145)	745 (227)	1908 (582)
35	262 (80)	409 (125)	639 (195)	1636 (499)
40	229 (70)	358 (109)	559 (170)	1431 (436)
45	204 (62)	318 (97)	497 (151)	1272 (388)
50	183 (56)	286 (87)	447 (136)	1145 (349)
55	167 (51)	260 (79)	407 (124)	1041 (317)
60	153 (47)	239 (73)	373 (114)	954 (291)
65	141 (43)	220 (67)	344 (105)	881 (268)
70	131 (40)	204 (62)	319 (97)	818 (249)
75	122 (37)	191 (58)	298 (91)	763 (233)
80	114 (35)	179 (55)	280 (85)	716 (218)
85	108 (33)	168 (51)	263 (80)	674 (205)
90	102 (31)	159 (48)	248 (76)	636 (194)
95	96 (29)	151 (46)	235 (72)	603 (184)
100	92 (28)	143 (44)	224 (68)	572 (174)
110	83 (25)	130 (40)	203 (62)	520 (159)
120	76 (23)	119 (36)	186 (57)	477 (145)

<b>Transmission Power (W)</b>	<b>Transmission Distance (Diameter: 0.80)</b>	<b>Transmission Distance (Diameter: 1.00)</b>	<b>Transmission Distance (Diameter: 1.25)</b>	<b>Transmission Distance (Diameter: 2.00)</b>
130	70 (21)	110 (34)	172 (52)	440 (134)
140	65 (20)	102 (31)	160 (49)	409 (125)
150	61 (19)	95 (29)	149 (45)	382 (116)
160	57 (17)	89 (27)	140 (43)	358 (109)
170	54 (16)	84 (26)	132 (40)	337 (103)
180	51 (16)	80 (24)	124 (38)	318 (97)
190	48 (15)	75 (23)	118 (36)	301 (92)
200	46 (14)	72 (22)	112 (34)	286 (87)

# 9 Cable Diameter (48 VDC) and Transmission Distance

The recommended transmission distances are for reference only, and the actual conditions shall prevail. The following table shows the maximum transmission distance of cables with certain diameter when the 48 VDC power source voltage loss rate is below 25%.

For devices powered by direct current, the maximum voltage loss rate allowed is 25%.



In the following table, the unit for diameter is mm, and the unit for transmission distance is foot (m).

Table 9-1 Cable diameter (48 VDC) and transmission distance

Transmission Power (W)	Transmission Distance (Diameter: 0.80)	Transmission Distance (Diameter: 1.00)	Transmission Distance (Diameter: 1.25)	Transmission Distance (Diameter: 2.00)
5	3257 (993)	5089 (1551)	7951 (2424)	20355 (6204)
10	1628 (496)	2544 (776)	3976 (1212)	10177 (3102)
15	1086 (331)	1696 (517)	2650 (808)	6785 (2068)
20	814 (248)	1272 (388)	1988 (606)	5089 (1551)
25	651 (199)	1018 (310)	1590 (485)	4071 (1241)
30	543 (165)	848 (259)	1325 (404)	3392 (1034)
35	465 (142)	727 (222)	1136 (346)	2908 (886)
40	407 (124)	636 (194)	994 (303)	2544 (776)
45	362 (110)	565 (172)	883 (269)	2262 (689)
50	326 (99)	509 (155)	795 (242)	2035 (620)
55	296 (90)	463 (141)	723 (220)	1850 (564)
60	271 (83)	424 (129)	663 (202)	1696 (517)
65	251 (76)	391 (119)	612 (186)	1566 (477)
70	233 (71)	363 (111)	568 (173)	1454 (443)
75	217 (66)	339 (103)	530 (162)	1357 (414)
80	204 (62)	318 (97)	497 (151)	1272 (388)
85	192 (58)	299 (91)	468 (143)	1197 (365)
90	181 (55)	283 (86)	442 (135)	1131 (345)
95	171 (52)	268 (82)	418 (128)	1071 (327)
100	163 (50)	254 (78)	398 (121)	1018 (310)
110	148 (45)	231 (71)	361 (110)	925 (282)
120	136 (41)	212 (65)	331 (101)	848 (259)

<b>Transmission Power (W)</b>	<b>Transmission Distance (Diameter: 0.80)</b>	<b>Transmission Distance (Diameter: 1.00)</b>	<b>Transmission Distance (Diameter: 1.25)</b>	<b>Transmission Distance (Diameter: 2.00)</b>
130	125 (38)	196 (60)	306 (93)	783 (239)
140	116 (35)	182 (55)	284 (87)	727 (222)
150	109 (33)	170 (52)	265 (81)	678 (207)
160	102 (31)	159 (48)	248 (76)	636 (194)
170	96 (29)	150 (46)	234 (71)	599 (182)
180	90(28)	141(43)	221 (67)	565 (172)
190	86 (26)	134 (41)	209 (64)	536 (163)
200	81 (25)	127 (39)	199 (61)	509 (155)

# 10 Wire Gauge Reference Sheet

Metric Bare Wire Diameter (mm)	AWG	SWG	Bare Wire Cross Section Area (mm <sup>2</sup> )
0.050	43	47	0.00196
0.060	42	46	0.00283
0.070	41	45	0.00385
0.080	40	44	0.00503
0.090	39	43	0.00636
0.100	38	42	0.00785
0.110	37	41	0.00950
0.130	36	39	0.01327
0.140	35	/	0.01539
0.160	34	37	0.02011
0.180	33	/	0.02545
0.200	32	35	0.03142
0.230	31	/	0.04115
0.250	30	33	0.04909
0.290	29	31	0.06605
0.330	28	30	0.08553
0.350	27	29	0.09621
0.400	26	28	0.1257
0.450	25	/	0.1602
0.560	24	24	0.2463
0.600	23	23	0.2827
0.710	22	22	0.3958
0.750	21	/	0.4417
0.800	20	21	0.5027
0.900	19	20	0.6362
1.000	18	19	0.7854
1.250	16	18	1.2266
1.500	15	/	1.7663
2.000	12	14	3.1420
2.500	/	/	4.9080
3.000	/	/	7.0683