

Functionality and reliability

WIDE RANGE OF PRESSURE DROP INDICATORS

Wide range of pressure drop indicators for economic operation and increased reliability of the filter.

ROBUST DESIGN

High quality aluminium alloy and robust design assure reliable operation in demanding industrial applications.

AVELOCK™ ANTIVIBRATION ELEMENT LOCK SYSTEM

Filter elements are firmly supported by aluminium ribs. This significantly reduces mechanical load of the elements and reduces possibility of element damage by vibrations and pulsations.

X2-COAT™

CORROSION PROTECTION

KTL Cathoretic coating (internal & external) assures excellent chemical resistance to aggressive industrial or even salty environment. KTL also serves as excellent primer for external powder paint finish.



CONVENIENT ASSEMBLY / WALL MOUNTING

New AAF filter housings are equipped with convenient holes for easy assembly of several housings or mounting them to the wall.

XR, XM, XS

NEW FILTRATION GRADES

Improved filtration performance better chemical resistance and higher thermal stability thanks to the new drainage material.

WIDE RANGE OF CONDENSATE DRAINS

Besides an internal automatic condensate drain which is the most common choice, we offer a wide range of other automatic and electronic condensate drains which can be fitted on these housings.

Technical data

FILTER HOUSINGS										FILTER ELEMENTS											
Filter housing size	Pipe size	Max. operating pressure	Flow rate at 7 bar(g), 20 °C		Dimensions				Mass	B prefilter 15 µm	P prefilter 3 µm	XR prefilter 1 µm	XM microfilter 0.1 µm	XS finefilter 0.01 µm	A activated carbon	A² adsorption	H² catalyst	MS² adsorption	CKL separator		
			Nm³/h	scfm	A mm	B mm	C mm	D mm												kg	
AAF 0006 ¹⁾	1/8	16/232	10	6	105	55	14	50	0.23	-	3528 P	3528 XR	3528 XM	3528 XS	3528 A	-	-	-	3528 CKL		
AAF 0016 ¹⁾	1/4	16/232	18	11	125	55	14	70	0.24	-	5528 P	5528 XR	5528 XM	5528 XS	5528 A	-	-	-	5528 CKL		
AAF 0026	1/4	16/232	25	15	145	73	18	50	0.42	-	3844 P	3844 XR	3844 XM	3844 XS	3844 A	-	-	-	3844 CKL		
AAF 0036	3/8	16/232	30	18	145	73	18	50	0.42	-	3844 P	3844 XR	3844 XM	3844 XS	3844 A	-	-	-	3844 CKL		
AAF 0046	1/4	16/232	35	22	189	88	21	60	0.72	6050 B	6050 P	6050 XR	6050 XS	6050 A	-	-	-	-			
AAF 0056	3/8	16/232	60	35	189	88	21	60	0.6	6050 B	6050 P	6050 XR	6050 XS	6050 A	-	-	-	6050 CKL			
AAF 0076	1/2	16/232	78	46	189	88	21	80	0.6	7050 B	7050 P	7050 XR	7050 XS	7050 A	7050 A²	7050 H²	7050 MS²	7050 CKL			
AAF 0106	3/4	16/232	120	70	257	88	21	150	0.7	14050 B	14050 P	14050 XR	14050 XS	14050 A	14050 A²	14050 H²	14050 MS²	14050 CKL			
AAF 0186	1	16/232	198	116	261	125	37	160	1.2	12075 B	12075 P	12075 XR	12075 XS	12075 A	12075 A²	12075 H²	12075 MS²	12075 CKL			
AAF 0306	1	16/232	335	197	361	125	37	250	1.6	22075 B	22075 P	22075 XR	22075 XS	22075 A	22075 A²	22075 H²	22075 MS²	-			
AAF 0476	1 1/2	16/232	510	300	461	125	37	350	1.9	32075 B	32075 P	32075 XR	32075 XS	32075 A	32075 A²	32075 H²	32075 MS²	32075 CKL			
AAF 0706	1 1/2	16/232	780	459	641	125	37	530	2.6	50075 B	50075 P	50075 XR	50075 XS	50075 A	50075 A²	50075 H²	50075 MS²	-			
AAF 0946	2	16/232	1000	588	696	164	50	520	5.7	51090 B	51090 P	51090 XR	51090 XS	51090 A	-	-	-	51090 CKL			
AAF 1506	2	16/232	1500	882	943	164	50	770	7.6	76090 B	76090 P	76090 XR	76090 XS	76090 A	-	-	-	76090 CKL			
AAF 1756	2 1/2	16/232	1680	990	943	164	50	770	7.3	76090 B	76090 P	76090 XR	76090 XS	76090 A	-	-	-	76090 CKL			
AAF 2006	3	16/232	2160	1270	801	242	60	630	16.7	51140 B	51140 P	51140 XR	51140 XS	51140 A	-	-	-	51140 CKL			
AAF 2406	3	16/232	2760	1620	998	242	60	780	21.3	75140 B	75140 P	75140 XR	75140 XS	75140 A	-	-	-	-			
quality class - solids (ISO 8573-1)										7	6	3	2	1	1 ²⁾	1 ²⁾	1 ²⁾	1 ²⁾	-		
residual oil content (mg/m³)										-	-	-	<0.1	<0.01	<0.005	<0.005	<0.005	-	-		
quality class - oils (ISO 8573-1)										-	-	-	2	1	1	1	0/1	-	-		
pressure drop - new element [mbar / psi]										20 / 0,290	10 / 0,145	20 / 0,290	50 / 0,725	80 / 1,160	60 / 0,870	60 / 0,870	see spec.	see spec.	see spec.		
change filter cartridge at pressure drop [mbar / psi]										18	350 / 5,07	350 / 5,07	350 / 5,07	350 / 5,07	6 months ³⁾	6 months ³⁾	6 months ³⁾	6 months ³⁾	-		
filter material										sintered brass	acrylic fibres, cellulose	-	borosilicate micro fibres	-	borosilicate micro fibres	activ. carbon	activ. carbon	hopcalite	molecul. sieve	stainless steel	
pleated version										-	✓	✓	✓	✓	-	✓	✓	✓	-	-	
wrapped version										-	-	-	-	-	✓	-	-	-	-	-	
sintered version										✓	-	-	-	-	-	-	-	-	-	-	
min. operating temperature (°C / °F)										1,5 / 35	1,5 / 35	1,5 / 35	1,5 / 35	1,5 / 35	1,5 / 35	1,5 / 35	1,5 / 35	1,5 / 35	1,5 / 35	1,5 / 35	1,5 / 35
max. operating temperature (°C / °F)										65 / 149	65 / 149	65 / 149	65 / 149	65 / 149	45 / 113	45 / 113	45 / 113	45 / 113	65 / 149	-	
CORRECTION FACTORS																					
Operating pressure [bar]	2	3	4	5	6	7	8	9	10	11	12	13	14	15	16						
Operating pressure [psi]	29	44	58	72	87	100	115	130	145	160	174	189	203	218	232						
Correction factor	0,38	0,50	0,63	0,75	0,88	1	1,13	1,25	1,38	1,50	1,63	1,75	1,88	2,00	2,13						

Remarks:

- 1) Filter elements "A" must be changed periodically to suit application, but at least every 6 months. Activated carbon filters must not operate in oil saturated conditions.
- 2) Valid if "S" filter cartridge is installed upstream.
- 3) B filter element can be cleaned with ultrasonic bath or with back flushing. Interval of cleaning depends on application. If necessary replace filter element with new one. For size AAF 0006 and 0016 no differential pressure indicator and no internal condensate drain is available, IED not available.



OMEGA AIR d.o.o. Ljubljana
Cesta Dolomitskega odreda 10
SI-1000 Ljubljana, Slovenia
00 386 1 200 68 00
info@omega-air.si
www.omega-air.si

950446 - 10/2023



OMEGA AIR
more than air



COMPRESSED AIR FILTERS
AAF series

AAF series

The new series of filters is developed with a focus on functionality, reliability and ease of maintenance.

The expanded range of flow capacities means even greater usability of our basic line of filters, which now also cover applications with extremely low air flows and small sized pipe connections.

Installation is even easier and more reliable with the new connection design.

Technology, expertise and experiences, combined in the AAF series filters are the best solution to get the best air quality in your process, regardless of its size.

High quality compressed air was always our priority. Quality means less downtime of production processes, leading to your higher profits, and greater satisfaction as a professional in this field. Among other things, the internal and external surfaces of AAF series of filters is protected by KTL Cathoretic coating process as standard. KTL corrosion protection assures excellent chemical resistance to aggressive environment and also serves as an excellent primer for external powder paint finish.

Optional equipment

A wide range of condensate drains and pressure drop indicators can be installed on the filter housings, which can be selected from our production program.

To meet the requirements of compressed air quality according to ISO 8375-1 of your application, 9 types of filter elements of different filtration levels are available.

An element for cyclone condensate separation can also be installed in the same housing without additional modifications, which serves as the first-rough stage of condensate removal from the compressed air system.



NEW features

- A wider range of different models for different flow rates, including larger 2" and 3" sizes.
- Convenient design for assembly of several filters and for wall mounting
- AVELOCK antivibration element lock system
- Needle felt drainage layer instead of foam for improved thermal resistance
- X2-COAT internal anti-corrosion protection

AAF filter housing

operating pressure	16 bar
volume flow rate	10 to 2.760 Nm ³ /h
connections	1/8" to 3"
operating temp. range	1,5 to 65 °C
standard painting	RAL 7021
housing material	Aluminium

APPLICATIONS

- general industrial applications
- automotive
- electronics
- food and beverage
- chemical
- petrochemical
- plastics
- paint



Compressed air connections
Compressed air threaded connections can be carried out in the NPT or BSP version. By installing additional equipment multiple filters of equal size can be joined together. Preconfigured holes near the threaded connections are also used for installation of a wall mounting kit.



X2-COAT™
Corrosion protection is assured by KTL Cathaphoretic coating (internal & external), which provides excellent chemical resistance to aggressive industrial or even salty environment. KTL also serves as an excellent primer for external powder paint finish.



Sight glass
Sight glass has been developed for easy checking of level of condensate accumulated in the bottom of compressed air filter bowl. On every casted aluminium filter housing there is a pre-casted area where the sight glass can be mounted after appropriate holes are drilled.



WS/WM - Wall mounting kit
Wall mounting kits have been developed to easily mount filter on walls and other surfaces. The kit contains 2 mirror-shaped consoles made of stainless steel, which can be mounted together with the AK assembly kit for filters.



AK - assembly kit for filters
Assembly kits have been developed to connect two or more air filters together. The construction of assembly kit is universal and it can be used for any type of filter, including filters of some other world producers.



Optional equipment

PRESSURE DROP INDICATORS

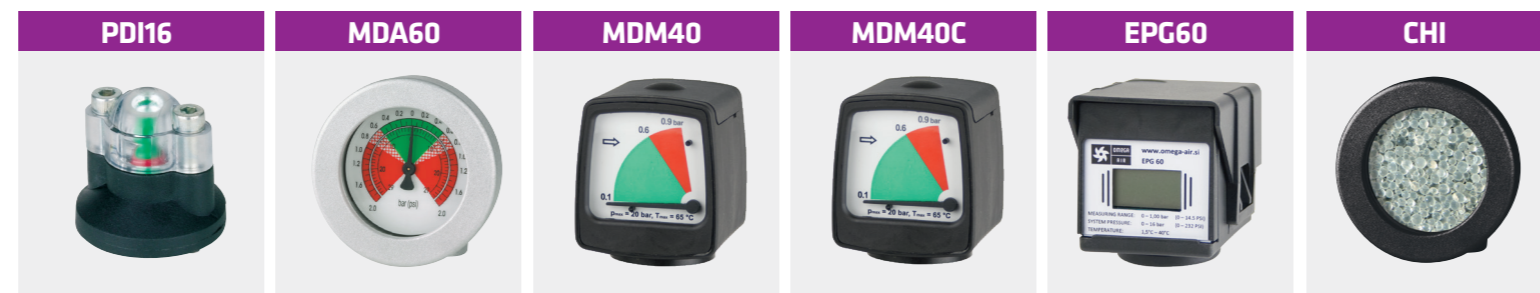

FILTER ELEMENTS

B 15 µm prefilter	P 3 µm prefilter	XR 1 µm prefilter	XM 0,1 µm general purpose filter	XS 0,01 µm super fine filter	A adsorption activated carbon	A² adsorption activated carbon	H² catalyst	MS² molecular sieve	CKL condensate separator
Layers: - sintered brass	Layers: - stainless steel expanded mesh - nonwoven layer - acrylic fibres, cellulose - stainless steel expanded mesh	Layers: - stainless steel expanded mesh - nonwoven layer - acrylic fibres, cellulose - stainless steel expanded mesh - needle felt	Layers: - stainless steel expanded mesh - nonwoven layer - depth fiber filter layer - borosilicate micro fibers - coalescing layer (borosilicate micro fibers) - stainless steel expanded mesh - needle felt	Layers: - stainless steel expanded mesh - nonwoven layer - depth fiber filter layer - coalescing layer (borosilicate micro fibers) - stainless steel expanded mesh - needle felt	Layers: - stainless steel expanded mesh - nonwoven layer - activated carbon media - depth fiber filter layer - borosilicate micro fibers - stainless steel expanded mesh	Layers: - stainless steel expanded mesh - hopcalite - nonwoven layer - depth fiber filter layer - borosilicate micro fibers - stainless steel expanded mesh	Layers: - stainless steel expanded mesh - nonwoven layer - depth fiber filter layer - borosilicate micro fibers - stainless steel expanded mesh	Layers: - stainless steel expanded mesh - molecular sieve - nonwoven layer - depth fiber filter layer - borosilicate micro fibers - stainless steel expanded mesh	Construction: - stainless steel construction - abs plastic insert

CONDENSATE DRAINS



Optional versions

AAF HT
Aluminium high temperature compressed air filters

- 10/13 bar operating pressure
- 10 to 2.760 Nm³/h volume flow rate
- 1/8" to 3" connections
- 1,5 to 120°C operating temperature range
- RAL 7021 standard colour

AAF HT filter housings are designed for very high efficient removal of solid particles, water and oil aerosols, from compressed air systems in **high temperature applications**.

To be able to achieve the required compressed air quality, an appropriate filter element (BHT, N25HT, N5HT, XRHT, XMHT, XSHT) must be installed into the filter housing.

For applications with other technical gases, please contact producer or your local distributor. Detailed information is available in our main catalogue.

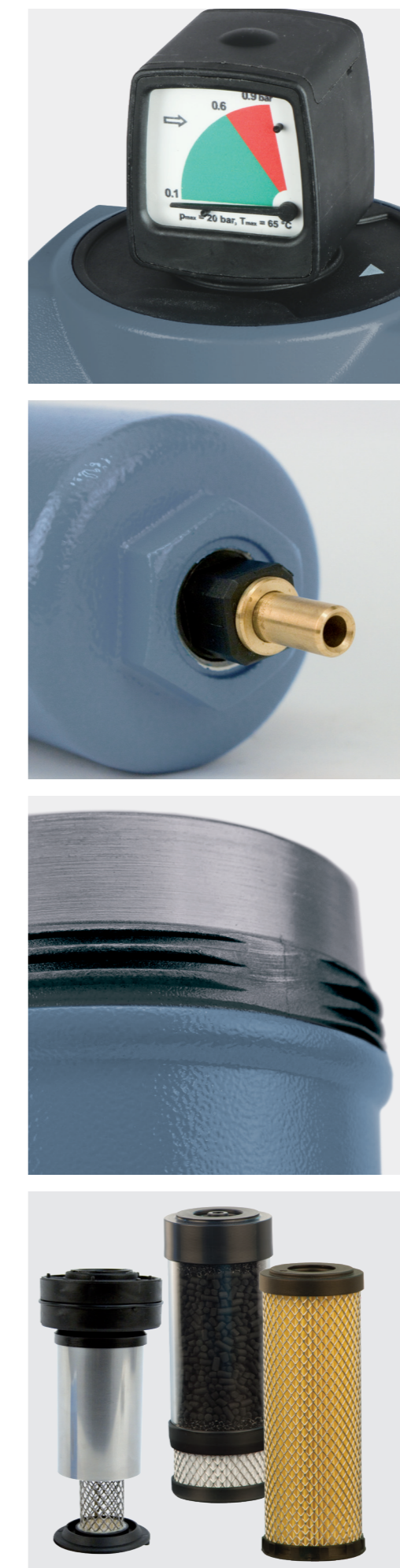

FA
Flange adapters for AAF series compressed air filters

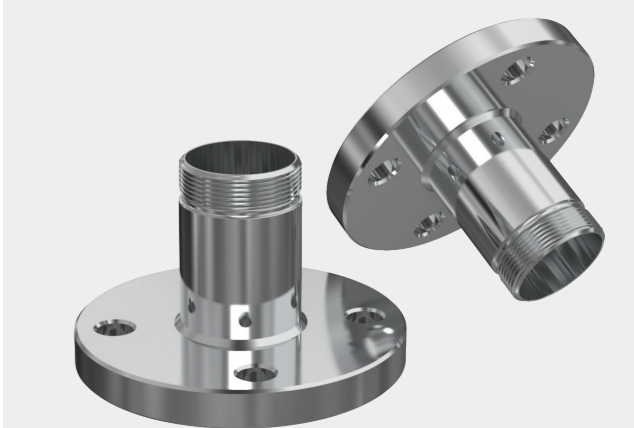

Flange adapter FA is designed for all products and devices that cannot otherwise be connected to the pipeline without flanges such as: filter housings, condensate drains, dryers, valves,

The product is made of a male pipe thread which can be screwed on to the female connection of the filter, which enables this to be coupled to another flange. The Flange adapter FA is completely protected from corrosion with zinc coating.

Type	Flange size	Thread conn. (1)	Pressure rating	Dimensions [mm]						Mass [kg]
				A	B	C	D	E	F	
FA 15	DN15	G 1/2"	PN16	95	65	4x Ø14	65	15	G 1/2	0,7
FA 20	DN20	G 3/4"	PN16	105	75	4x Ø14	65	15	G 3/4	1,0
FA 25	DN25	G 1"	PN16	115	85	4x Ø14	65	17	G 1	1,2
FA 32	DN32	G 1 1/4"	PN16	140	100	4x Ø18	85	17	G 1 1/4	2,1
FA 40	DN40	G 1 1/2"	PN16	150	110	4x Ø18	95	19	G 1 1/2	2,4
FA 50	DN50	G 2"	PN16	165	125	4x Ø18	105	21	G 2	3,2
FA 65	DN65	G 2 1/2"	PN16	185	145	4x Ø18	105	21	G 2 1/2	3,7
FA 80	DN80	G 3"	PN16	200	160	8x Ø18	105	21	G 3	4,7

(1) Standard flange EN 1092-1, other pipe connection on request.

