

SEMI-AUTOMATIC CAR TYRE CHANGER

Installation/Operation & Maintenance Manual

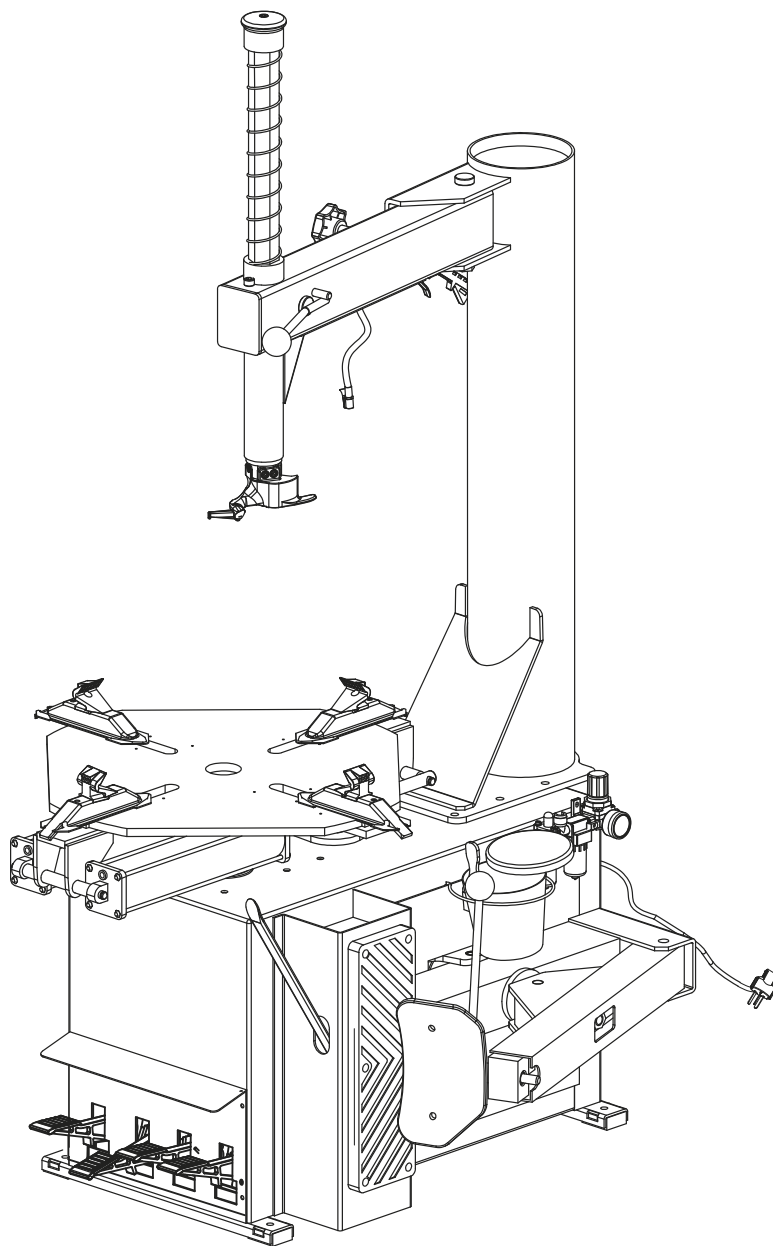

CE

MODEL: JTC820

Please read through this manual before operation. You must read and understand the precautions for safety to protect your safety and any damage to your property.

Version: HR201312.1.0

NOTE TO THE USER

Thank you for purchasing our products.
Please read this instruction carefully for safe and proper use of the tyre changer, and keep it handy for future reference.

- This Manual is for model : JTC820
- As for the assurance of safety in design and construction of car lift, read this Manual first.
- Please make sure that this manual is delivered to end users for their implementation of safety.
- Don't use the tyre changer in a potentially explosive atmosphere.

ANY PART OF THIS PRINT MUST NOT BE REPRODUCED
IN ANY FORM WITHOUT PERMISSION.
THIS PRINT IS SUBJECT TO CHANGE WITHOUT NOTICE.

TABLE OF CONTENTS

1. INTRODUCTION	1
1.1 SCOPE OF APPLICATION	1
1.2 DIMENSION OF THE MACHINE	1
1.3 TECHNICAL SPECIFICATIONS	1
1.4 STRUCTURE AND PARTS	2
1.5 WARBNING STICKERS AND INSTRUCTIONS ON THE MACHINE	2
1.6 LOCATION OF WARNING STICKERS AND INSTRUCTIONS ON THE MACHINE	4
2. INSTALLATION	5
2.1 TRANSPORTATION	5
2.2 INSTALLATION	5
3. COMMISSIONING	10
4. OPERATION	11
4.1 DEMOUNTING TYRES	11
4.2 MOUNTING TYRES	12
4.3 INFLATING	12
5. MAINTENANCE	13
APPENDIX	15
ELECTRICAL SCHEMATIC DIAGRAM	15

1. INTRODUCTION

1.1 SCOPE OF APPLICATION

The tyre changer is designed and made specially for changing the tyres of cars, vans, light trucks and motorcycle with the principle of best quality and highest working efficiency.



Note: This machine can only be used for the purpose designed by the manufacturer. Do not use it for any other purpose.

Any damage caused by incorrect using or beyond the scope of application will not be covered under warranty.

1.2 DIMENSION OF THE MACHINE

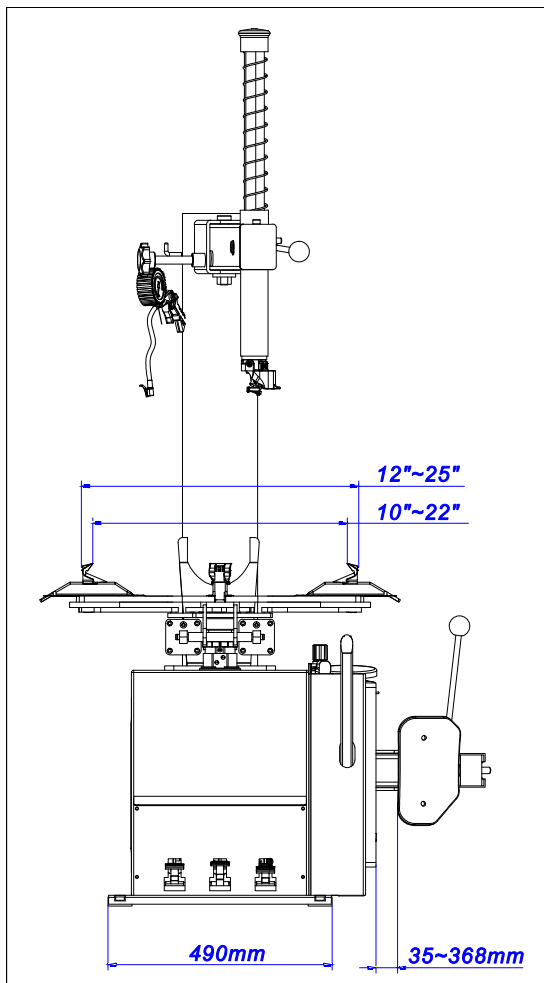

Fig. 1

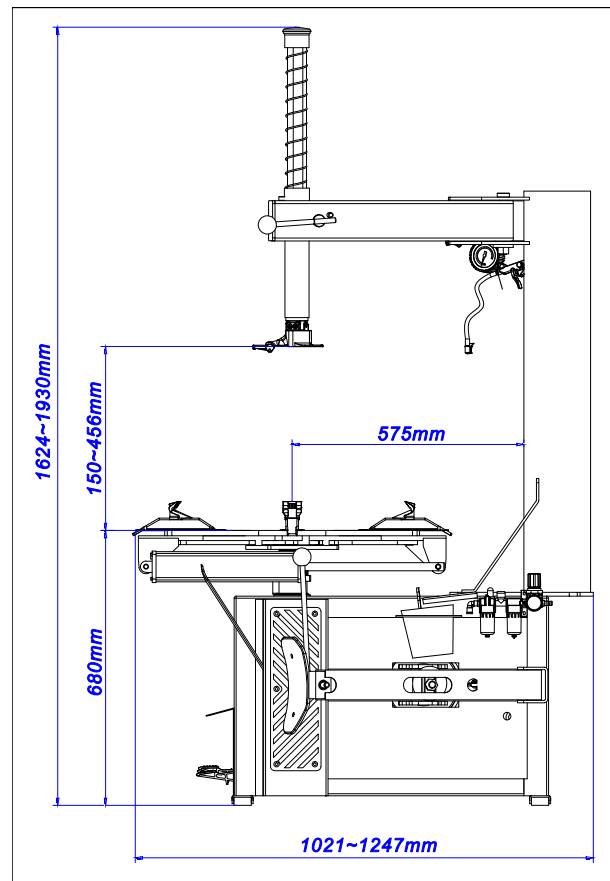

Fig. 2

1.3 TECHNICAL SPECIFICATIONS

Max. Wheel Width: 14"

Max. Wheel Diameter: 1150mm

Outside Locking (RIM): 12"-25"

Inside Locking (RIM): 10"-22"

Motor Power Supply: 380V/50Hz 0.75kw 3Ph

220V/50Hz 1.1kw 1Ph

110V/220V-50Hz/60Hz 1.1kw 1Ph

Shipping Weight: 284kg

Working Temperature: 0-45°C

Operating Pressure: 8-10bar

1.4 STRUCTURE AND PARTS

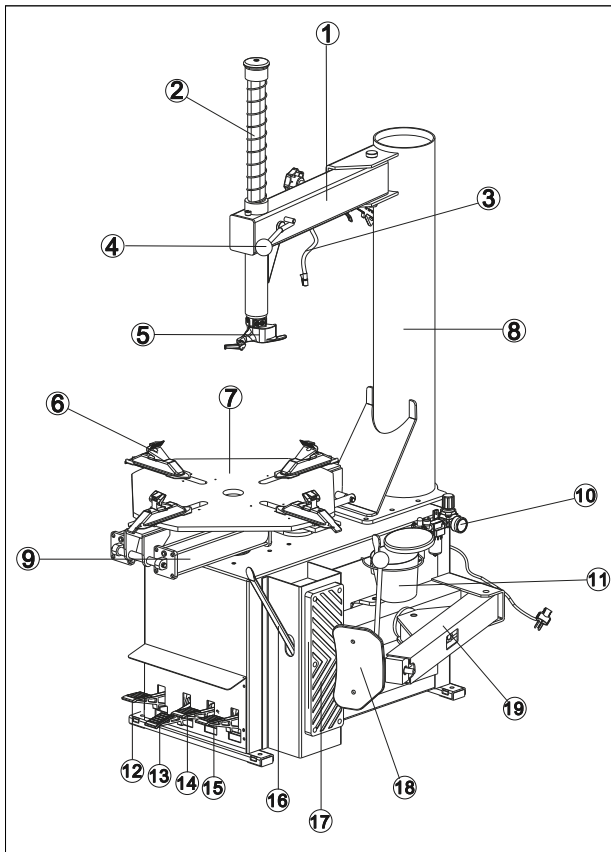

Fig. 3

- ① Horizontal arm
- ② Vertical slide
- ③ Inflating gauge
- ④ Locking handle for vertical slide
- ⑤ Mounting/demounting head
- ⑥ Wheel clamp
- ⑦ Turntable
- ⑧ Vertical post
- ⑨ Cylinder
- ⑩ Oil separator
- ⑪ Grease cup
- ⑫ Tyre inflation pedal

- ⑬ Wheel clamp opening/closing pedal
- ⑭ Bead breaker pedal
- ⑮ Turntable turning pedal
- ⑯ Tyre lever
- ⑰ Bead breaker pad
- ⑱ Bead breaker shoe
- ⑲ Bead breaker arm

1.5 WARNING STICKERS AND INSTRUCTIONS ON THE MACHINE



Risk of crushing. Stand clear of bead breaker arm during operation.



Never place hand on the tyre when the demounting head is on the working position, so as to avoid the injury of the operator.



Never place your hand between the tyre and the wheel clamping device when operate the rim, so as to avoid the injury of the operator.



The wheel clamps should be in closed position when do the bead breaking, so as to avoid the injury of the operator.



Never place hand between bead breaker and the machine body when the bead breaker is on the working position, so as to avoid the injury of the operator.



Risk of eye injury. High pressure air will come out when unplug the hose of air compressor which may cause injury to the eyes of operator.



Risk of electrical shock. High voltages are present within the base unit.



Risk of eye injury. Flying debris, dirt, and fluids may be discharged during bead seating and inflation process.



Wear gloves during operation.



Wear working clothes during operation.



Max. operating pressure: 10 bar.

WARNING!

TO PREVENT ACCIDENTS AND INJURIES READ INSTRUCTIONS BEFORE OPERATION.

SAFETY INFORMATIONS

- Failure to read and observe all warnings and instructions could cause injury or death.
- Before using this machine read and understand all warnings and the Instruction Manual provided with this tyre changer.
- Follow all warnings and instructions during use.
- Do not cover warnings and instruction during use.
- Unreadable and missing warning labels must be replaced immediately. Don't use the tyre changer if one or more labels are unreadable or missing.

CAUTION!

RISK OF ELECTRIC SHOCK. DO NOT OPEN COVER.

WARNING!

TO REDUCE THE RISK OF ELECTRIC SHOCK. DO NOT EXPOSE THIS TYRE CHANGER TO RAIN, WATER OR WET LOCATIONS.

WARNING!

THIS TYRE CHANGER DOES NOT CONTAIN USER SERVICEABLE PARTS. DO NOT OPEN COVER. DO NOT TAMPER WITH COMPONENTS. FAILURE TO COMPLY MAY CAUSE SERIOUS INJURY OR DEATH TO OPERATOR OR BYSTANDER.

ATTENTION: DANGER!

Tyre or wheel failure under pressure may cause serious injury by explosion.

NEVER EXCEED 40 PSI WHILE SEATING BEADS.

NEVER EXCEED TYRE MANUFACTURER'S RECOMMENDED PRESSURE AFTER SEATING BEADS.

NEVER LEAN OR REACH OVER TYRE OR RIM DURING INFLATION.

An exploding tyre and rim may be propelled upward and outward with enough force to cause serious injury or death. This tyre changer is not a safety device and will not restrain exploding tyres and rims.

THE TYRE MAY EXPLODE WHEN:

- 1) The rim diameter does not match the tyre diameter.
- 2) The rim or tyre are defective.
- 3) The beads are seated exceeding recommended pressure.
- 4) The tyre is inflated beyond the tyre manufacturer's instructions.
- 5) The operator does not follow proper safety rules.

IMPORTANT SAFETY RULES

- A) Only trained operators should use this machine.
- B) Remove all air from tyre before loosening beads. Remove valve core.
- C) Remove all wheel weights from rim before mounting or demounting.
- D) Always use a proper bead lubricant before mounting, demounting and seating beads.
- E) Always verify that the tyre and the rim are exactly the same bead diameter. Tyre size is molded into the sidewall. Rim size is stamped into the rim. Never mount a tyre on a rim if the bead diameter cannot be identified.
- F) Inspect the tyre and rim carefully for defects. Do not mount the tyre if any defects are found.
- G) Seat beads and inflate the tyre with short bursts of air while continuously checking the air pressure.
- H) Stand away from the tyre and wheel while inflating. Never lean or reach over the tyre during inflation. Keep area clear of bystanders.
- I) Never exceed the tyre manufacturer's recommended maximum air pressure. Tyres can burst when inflated beyond specified limits.

DANGER!

Do not mount any tyres unless the tyre size (molded into the sidewall) matches the rim size (stamped into the rim) exactly!

2. INSTALLATION

2.1 TRANSPORTATION



Make sure transport the machine with its original package, and place it according to the marks on the package. The packed machine should be moved by means of a fork lift truck of suitable capacity, insert the forks at the points shown in (Fig. 4).

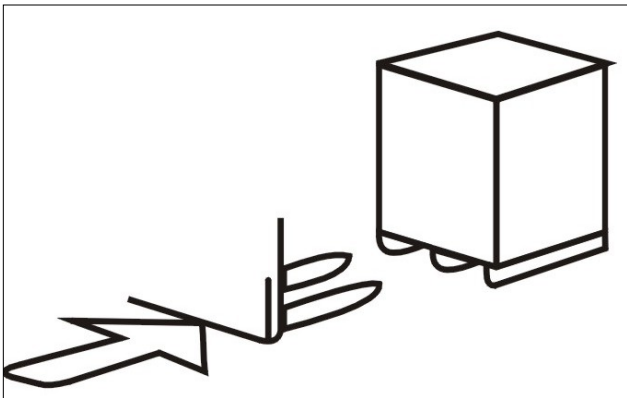

Fig. 4

The temperature for the transportation should be -25 to +55, some measure should be use to prevent the humidity, shake and concussion.

2.2 INSTALLATION

2.2.1 INSTALLATION PLACE

When choose the place for installation be sure that it complies with current safety regulations.

The semi-automatic tire changer must be connected to the main electric power supply and air compressed system. It is therefore advisable to install the machine near these power sources.

The place of installation must provide at least the space shown in **Fig. 5**, so as to allow all parts of the machine to be operated correctly and without any restriction.

If the machine is installed outside, it must be protected by a lean-to.

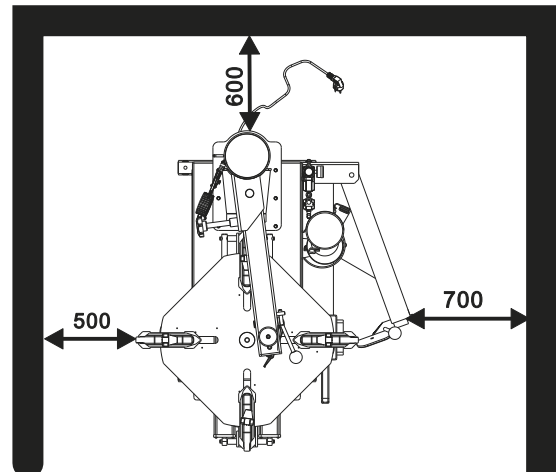

Fig. 5

2.2.2 UNPACKING

After unpacking the package, check the eyeable damage on the machine and the component due to the shipment, if there is some problems please contact with the dealer. The packing material such as plastic, nail, screw, wood and carton should be put into the waste box or be handled according to the local regulations.



Note: The operator should wear gloves, so as to avoid the injury when unpack the machine.

2.2.3 INSTALLATION PROCEDURE

The semi-automatic tyre changer is disassemble packed before delivery, the vertical arm are disassembled before packed, the customer should assemble it according to the manual.

2.2.3.1 Vertical post installation

- Unpack the package carton, take out accessory boxes, bead breaking arm and column assembly.



Fig. 6

- And position the machine body according to the Fig. 6. Remove the bolt, elastic washer and plate washer on the body.
- Place the vertical post on the body. The direction of the warning label is forwards. Make the holes on the column base plate align to thread holes on the body. Once again assemble the removed bolt, elastic washer and plate. The torque is 70 N·M (Fig. 7). Use torsion wrench to tight.

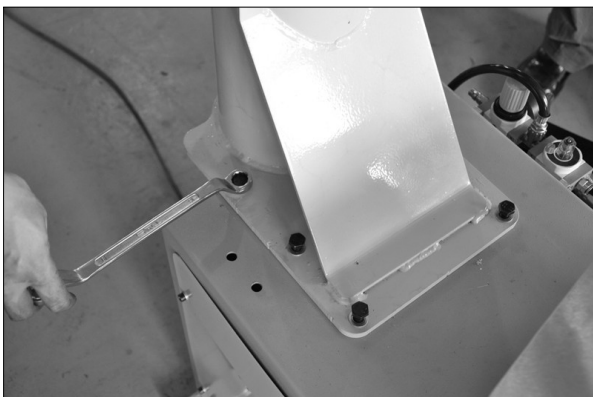

Fig. 7

- Use a wrench to remove the screw (Fig. 8-2) of vertical slide (Fig. 8-3) and take off the vertical slide cap (Fig. 8-1). When remove the screw on the vertical slide cap, you need use the locking handle to lock the vertical slide to avoid sliding off to damage the machine or injure personnell!

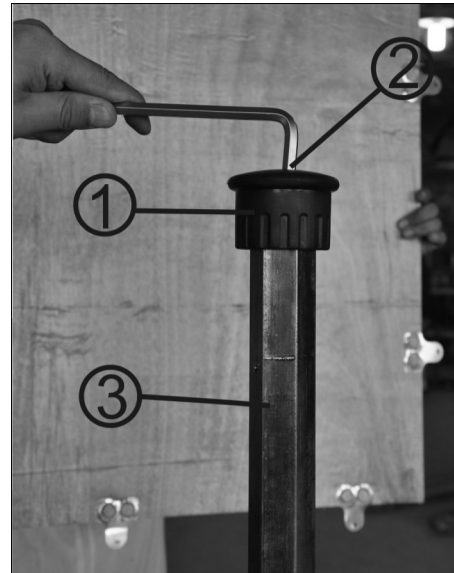

Fig. 8

- Install the vertical slide spring (Fig. 9) on the vertical slide. Mount the vertical slide cap and the removed screw. Assemble the vertical slide locking arm into the nut bushing of the horizontal arm (Fig. 10).



Fig. 9

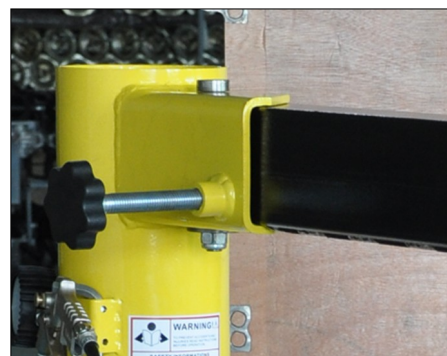

Fig. 10

2.2.3.2 BEAD BREAKER INSTALLATION

- Remove the lock nut at the front end of the bead breaking cylinder piston rod (**Fig. 11**) and use wrench to remove the nut on the bead breaking arm bolt. Remove the bolt and hang the spring.



Fig. 11

- Position the bead breaking arm shaft bushing into the bead breaking support plate on the body to align the hole and install the bead breaking bolt and assemble the nut to lock. (**Fig. 12**)



Fig. 12

- Insert the piston rod through the hole of the bead breaking slide bushing. (**Fig. 13**) The surface of the slide bushing should be outwards. Assemble the removed nut into the front end of the piston rod. (**Fig. 14**) The nut will be assembled. The distance from the edge of the bead breaking blade to the bead breaking rubber is 30~40mm.



Fig. 13



Fig. 14

- Hang the spring. (**Fig. 15**)



Fig. 15

- Loose the locking nut of the bead beaker shoe. (**Fig. 16**) Adjust the bead breaker shoe to its proper position and tighten the nut. (**Fig. 17**)

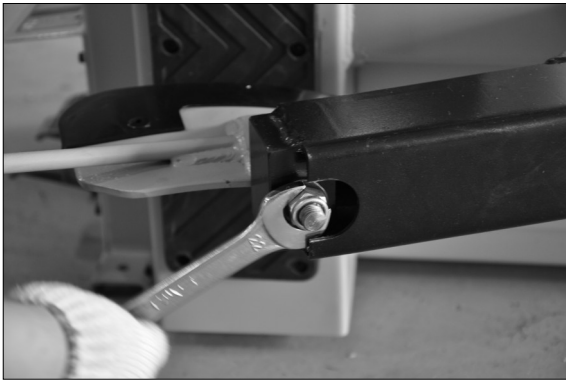

Fig. 16



Fig. 17

2.2.3.3 OIL SEPERATOR INSTALLATION

When the machine out of the factory, the air source fitting has been detached and placed in the accessory box and the fitting will be installed when it is in the site of the customers again.



The OIL SEPERATOR installation must be done only by qualified personnel.

Excessive air pressure can seriously injure personnel and damage the machine.

- **Preparation**

Prepare one crosshead screwdriver, take out the oil separator and two screws M4 from the accessory box, check the oil separator, clean the surface. (Fig. 18)



Fig. 18

- **Fix oil separator**

Fix the oil separator with screws M4 on the machine, adjust the oil separator in one level, then tighten the two screws M4. (Fig. 19)

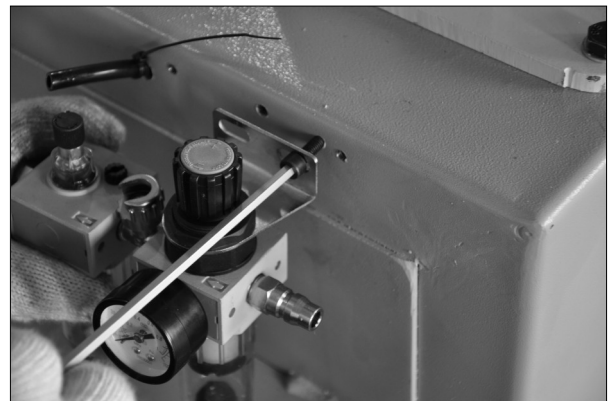

Fig. 19

- **Connect air hose**

Connect the main hose first, remove the strap (which can avoid the hose slide into the box) on the main hose, then connect the main hose with the union of oil separator (Fig. 20). Connect the hose on the gauge cover, with the seat in the oil separator, then tighten the union. (Fig. 21)

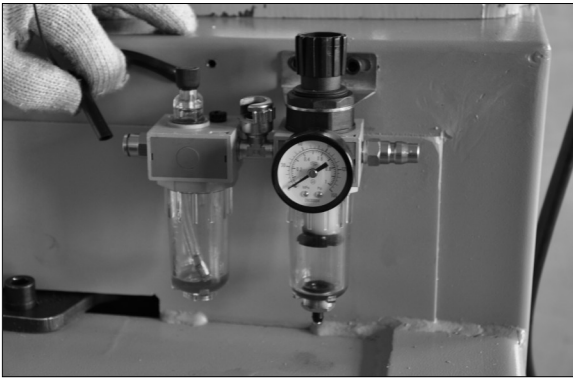

Fig. 20



Note: the go-out of the oil and the pressure have been adjusted before the delivery, so it is not necessary to adjust themselves.

2.2.3.4 GREASE CUP INSTALLATION

Insert the grease cup clamps into the two holes on right side of the machine. (Fig. 23) And put the grease cup into the clamp. (Fig. 24)

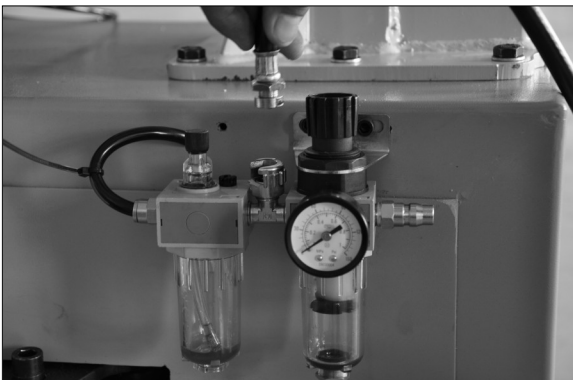

Fig. 21



Fig. 23

- Check



Before connecting the machine to the air supply, be sure all personnel are clear of the machine and no items are left on the turntable.

Connect the air supply after the connecting of the hose, to check if there are leak or not, if there is no, the customer can use the machine (Fig. 22).



Fig. 24



Fig. 22

3. COMMISSIONING



Before connecting the machine to the air supply, be sure all personnel are clear of the machine and no items are left on the turntable.

- Connect the air supply after the connecting of the hose, to check if there are leak or not, if there is no, the customer can use the machine (**Fig. 25**).



Fig. 25



Note: the go-out of the oil and the pressure have been adjusted before the delivery, so it is not necessary to adjust themselves.

- Check the three pedals are in their original position; connect the air source, the operation can begin when the pressure up to 8-10bar.



Note: After the connection with the air source, the clamp on the turntable should automatic open, which is set before delivery.

- When the pedal (15) is pressed down, the turntable should turn in a clockwise direction. When the pedal is pulled up, the turntable should turn in an anti-clockwise direction.
- When the pedal (13) is pressed down, the clamps on the turntable close. (when lightly step the pedal the machine can show the step moving function.) when the pedal is pressed again, the clamps open.

- When the pedal (14) is pressed down, the bead breaker blade will begin to move. When the pedal is released the bead breaker blade returns to its original position.
- In the meantime, please check towards the body to see if the oil separator works well. Normally, it will drop one drop of oil after the pedal is pressed for 5-6 times. If it drops too quick or too slow, please adjust the index on the air regulator by a screwdriver.



Notes: The machine must be fixed well to avoid the shake during the operation.

The machine must place on the ground completely.

Cut off the air and electric power sources before any maintenance.

Check the screws on every parts of the machine is tight.

Keep the human body and hands away from the moving parts of the machine during the operation. The necklace, bracelet, loose clothes and long hair is dangerous for the operators. The operator should wear safe clothes such as gloves and glasses.

Keep the working area tidy and clean, or it may cause sudden accident

The working area should be well lighted.

4. OPERATION



Never use the machine before read this instruction and warning carefully.

Before mounting a tyre on a rim, pay attention to the following:

The rim must be clean and in good condition: if necessary, clean it after removing all wheel weights including tape weights inside the rim.

The tyre must be clean and dry, without any damage to the bead.

Replace the rubber valve system with a new one or replace the O-ring if the valve system is made of metal.

If the tyre requires a tube, make sure the tube is dry and in good condition.

Lubrication is necessary to mount the tyre correctly and get a proper centering. Be sure you are using approved lubricant only.

Make sure the tyre is the correct size for the rim.

4.1 DEMOUNTING TYRES

- Place the tyre between the bead breaker blade and rubber pad, and place the blade on the bead 2 cm from the rim, step on the pedal (14) to separate the bead from the rim. **(Fig. 26)** The wenthole on the tyre should not near to the bead breaker blade during the operation.



Fig. 26

- Repeat above steps on the other parts of the tyre to get the tyre separated thoroughly from the rim.
- Set the vertical slide in the working position, so that the mounting/demounting head is near the rim. The roller in the mounting/demounting head should be 2 mm from the rim to prevent scratching the rim. **(Fig. 27)** Pull the locking handle to lock the vertical slide.

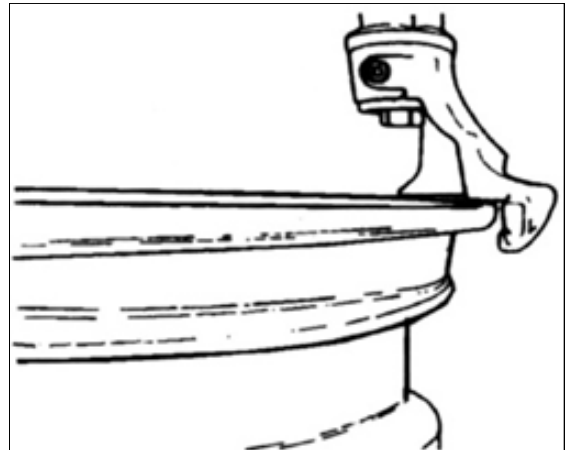

Fig. 27

- Lift the bead onto the mounting/demounting head with tyre lever, and step on the turntable turning pedal (15) to turn the turntable clockwise till the bead is completely separated **(Fig. 28)**. It is suggested to place the mounting/demounting head about 10 mm to the right side of the air valve if the wheel has a tube, so as not to damage the tube.

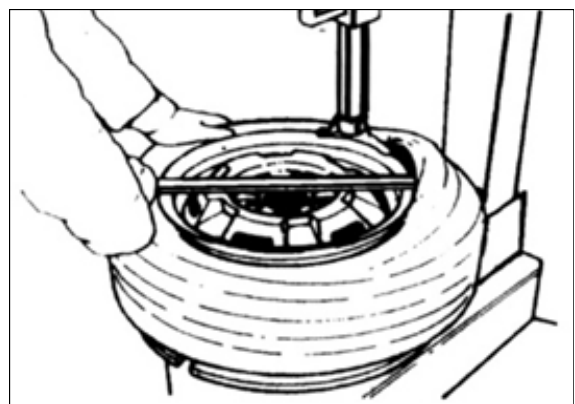

Fig. 28

- Take out the tube if there is. Turn over the wheel to let the other side toward the mounting/

demounting head, and repeat the above steps to demount the other side of the bead. (Fig. 29)

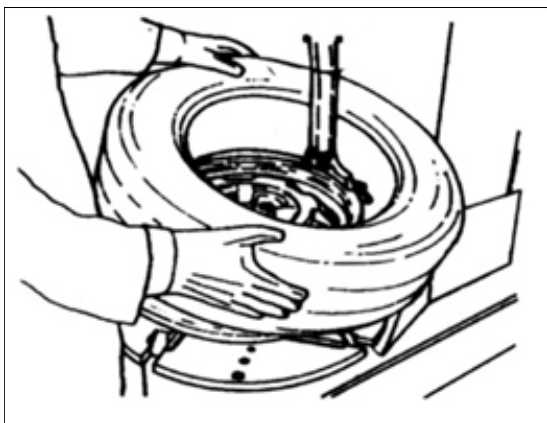

Fig. 29

4.2 MOUNTING TYRES



Note: Make sure that the size of the rim and the tire is the same before mounting.

- Clamp the rim on the turntable.
- Lubricate the bead with soap solution.
- Place one side of the tyre on the upside of the tail of the mounting/demounting head, then press the other side of the tyre under the mounting/demounting head, to make the tyre enter the groove of the rim. (Fig. 30) Pressing the pedal (15) to turn the turntable clockwise, and complete mount the bottom part of the tyre on the rim.



Fig. 30

- Cover the tube onto the rim if there is. Repeat the above steps to mount the upper bead.



Do not put your hand between the tyre and clamps. (Never adjust the pressure control valve inside the machine, otherwise the locking valve might be damaged.)

4.3 INFLATING



Keep your hand and body away from the tyre during the operation, and do the inflation carefully, so as to avoid the injury.

Inflate the tyre strictly following instruction below, please note there is no protection device for the safety of the operator (or third person) on the machine if the tyre explode suddenly.

Make sure the rim has the same size as the tyre, and the tire is not damaged before the inflation.

- Loose the tyre from the turntable.
- Connect the inflator with the air valve on the tire. (Fig. 31)



Fig. 31

- Press the inflating pedal (12) slowly for several times. Make sure the reading on the gauge does not exceed the manufacturer's limit.

5. MAINTENANCE



Note: Only the trained operator can do the maintenance.

It is necessary to do the maintenance in accordance with this manual periodically, to correctly use the machine and prolong the working life of the machine. Otherwise, the operation and the reliability maybe affected, and it may injury the operator or the third person near the machine.



Note: Shut off the power and air source before any maintenance, and release all the compressed air from the machine.

- Keep the machine and the working area clean to avoid the dust entering the moving parts.
- Check the oil level in the air-compressed cup periodically. If it needs to be filled, you must shut off air source, and then fill the SAE30 oil.
- Clean and lubricate all the moving parts of the turntable. (Fig. 32)

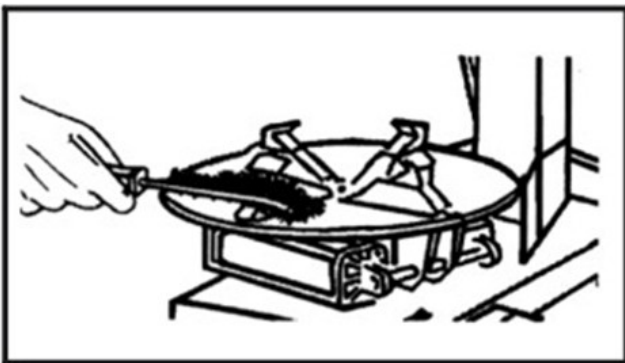

Fig. 32

- Check all connecting parts and bolts periodically and tighten them if necessary.
- Keep the horizontal arm clean and lubricate it periodically to make it move smoothly. (Fig. 33)

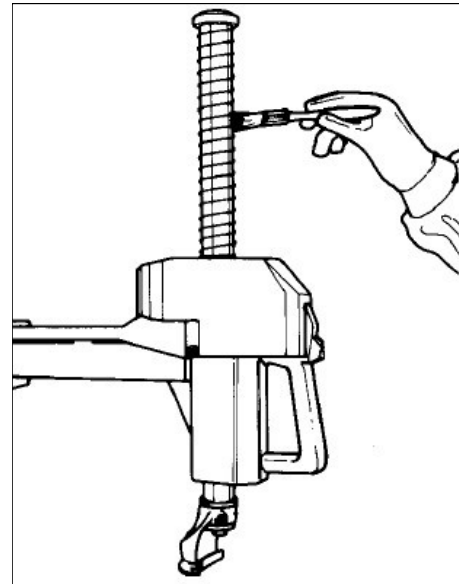

Fig. 33

- Lubricate all the connecting surface that may bring the displacement and attrition with oil weekly.
- Prepare a water segregator near the air-compressor, to reduce the amount of the water in the air that go through the machine.



Note: Shut off the power and air sources before the operation.

- Check and adjust the tension of the driving belt, to make sure that the turntable can running well. Loose the screw on the left panel of the machine to demount the panel, and then adjust the nut on the motor to loose and tighten the belt. (Fig. 34)

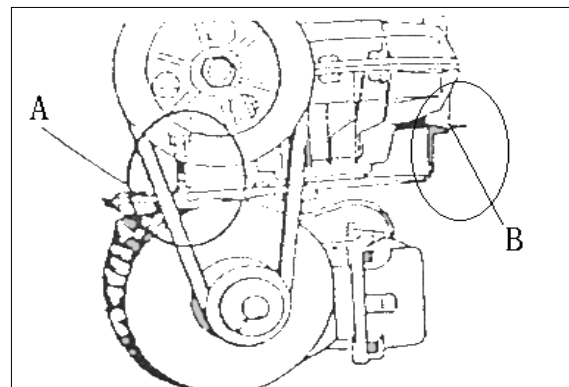

Fig. 34

- Do the adjustment as follow steps, if the vertical shaft does not lock well.
- ◇ Shut off the pneumatic supply.
- ◇ Demount the vertical arm cover.
- ◇ Adjust the nut near the thread rod by spanner, or lock the screw at back of the locking plate.
- ◇ Connect the pneumatic supply and observe the locked position, the vertical arm rise up for 3-4mm.

APPENDIX

ELECTRICAL SCHEMATIC DIAGRAM

A. 220V-50hz/60hz 1P 1.1KW

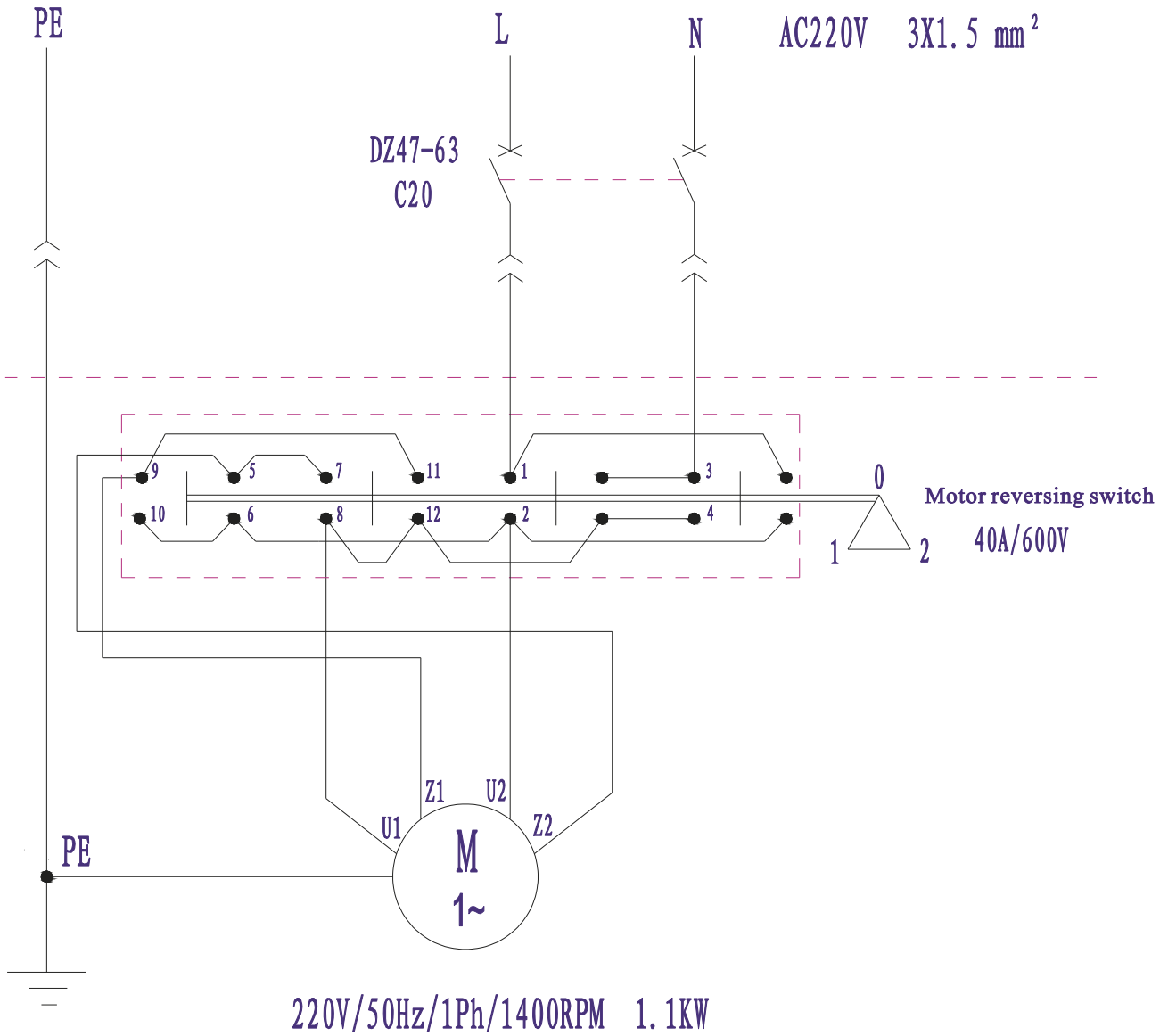

ELECTRICAL SCHEMATIC DIAGRAM

B. 380V-50hz/60hz 3P 0.75KW

