

ProcessesStick, TIG, MIG, Flux-Cored, Plasma Cutting, Grinding⁽¹⁾**Product Number**

7214700700 DownFlex® 200-M
 7244700700 DownFlex® 400-MS/A
 7204700700 DownFlex® 100-NF

Input Power200-M & 400-MS/A:
415V/3/50**Input Current**200-M & 400-MS/A:
5A**Weight/Dimensions (H x W x D)**

200-M:
245 kg
920 x 1380 x 1005 mm
 400-MS/A:
255 kg
920 x 1380 x 1005 mm

ADVANTAGE**FEATURES****DOWNFLEX® 200-M AND 400-MS/A:**

- ▶ **Strong Backdraft (80%) and Downdraft (20%) Extraction Capacity** - Ideal for welding, grinding⁽¹⁾, and light duty plasma cutting.
- ▶ **Industry Leading Three Stage Spark Arrestor System** - Captures hot particulate before it can get into the filter chamber.
- ▶ **Oval Shaped Filters Deliver an Impressive 52 m² of Total Filter Media** - Results in longer filter life.
- ▶ **All Controls and Doors on Front** - Offers complete access to filters and collection draws for easy maintenance.
- ▶ **CE Approved.**

APPLICATIONS

- ▶ **Welding**
- ▶ **Plasma Cutting**
- ▶ **Grinding⁽¹⁾**

KEY OPTIONS ⁽²⁾

- ▶ 0040000010 HEPA Filter Kit
- ▶ 0040400020 Plasma Cutting Work Grid
- ▶ 0040300030 Working Light Kit
- ▶ 0040400040 Wheel Kit
- ▶ 0040200020 Backdraft Kit
- ▶ 0040200030 Side Panels

WHAT'S INCLUDED

- ▶ Sturdy Welding Table
- ▶ Filters and Controls⁽²⁾



Shown:
7244700700
DownFlex® 400-MS/A
with backdraft kit and
side panels.

INPUT ⁽²⁾**Rugged Workbench and Fume Extraction Downdraft Table**

Lincoln Electric's DownFlex® table is a dual purpose workbench and extraction unit, designed specifically for the removal of welding fume at the source. It can also be used to remove particulate and dust from metal grinding applications, as well as fume and particulate from light duty plasma arc cutting.

TECHNICAL SPECIFICATIONS

Product Name	Product Number	Filter Type/ Filter Size	Input Power Voltage/Phase/ Hertz	Input Current	Noise Level Input Current	Dimensions H x W x D mm	Net Weight kg
DownFlex® 200-M	7214700700	Cellulose/Poly- ester Fiber Filter/ 52 m ²	415/3/50	5A	74 dbA	920 x 1380 x 1005	245
DownFlex® 400-MS/A	7244700700				69 dbA (w/ Silencer installed)		
					67 dbA (w/ Silencer and HEPA Filter installed)		255
DownFlex® 100-NF	7204700700	No Filtration	N/A		N/A	920 x 1366 x 911	150

(1) Not suitable for grinding Aluminum, Magnesium or other explosive materials.

(2) 200-M and 400-MS/A only.

(2) Back draft kit and side panels required for all welding applications with 200-M and 400M S/A

DownFlex® Downdraft Tables

A CLOSER LOOK

DownFlex® 200-M and 400-MS/A Models

1. Highly efficient welding, grinding and plasma cutting backdraft panel (80% backdraft / 20% downdraft).
2. Work table size:
1366 x 750 mm
Work load:
200 kg only, 150 kg with wheel kit installed.
3. All controls and doors on front for easy access.
4. Powerful Extraction Motor
2500 m³/h.
5. Dual LongLife filters with 52 m² of total surface area.
6. Pull out drawers for easy cleaning.
7. Hinged / removable side panels for larger parts.

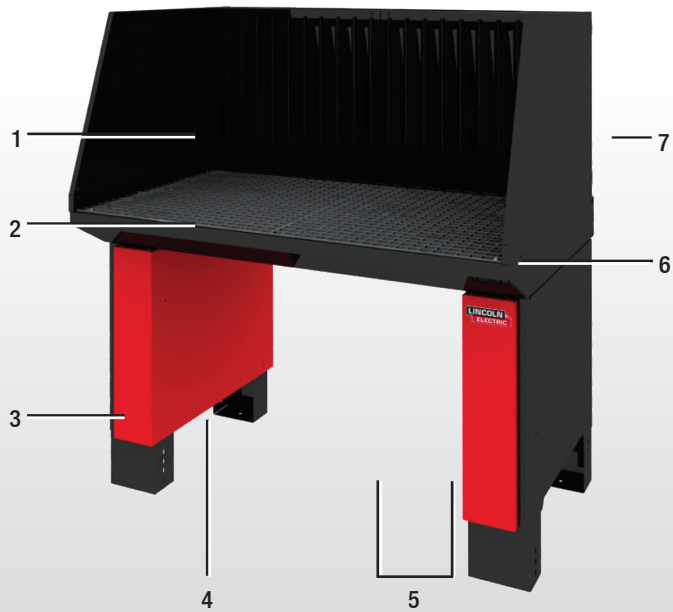

- ▶ **DownFlex® 200-M** comes with disposable filters for light to medium duty applications.



- ▶ **DownFlex® 400-MS/A** comes with automatic self-cleaning controls and disposable filters for medium to heavy duty applications. (Requires 500-800kPa compressed air.)



- ▶ **DownFlex® 100-NF** model is available for customers who need a rugged downdraft table, but prefer to build their own customized extraction system. (No filtration, fan or electrical controls supplied. Some assembly is required.)

DownFlex® Downdraft Tables

A CLOSER LOOK



▶ Strong Backdraft

80% of extraction is through backdraft, 20% is downdraft. (DownFlex® 100-NF shown with optional Central System Connector Kit).



▶ Easy Access

Access to filter chamber from the front of the downdraft table makes filter replacement convenient. No need to move table for maintenance. Oval shape of the filters increases surface area available for filtration.



▶ Locking Doors

Lock on filter chamber door restricts unauthorized access. Control panel door has separate lock to manage access to changeable control parameters and blower unit.



▶ Control Panel

Simple, easy-to-use layout includes main power switch, unit on/off switch, 120V receptacle, filter life gauge, and manual cleaning button (400-MS/A model only).



▶ Removable Side Panels

Side panels are hinged and can be removed for larger parts. (DownFlex® table shown with optional Silencer/Outlet Duct and Start/Stop Motion Activated Sensor installed).



▶ Adjustable Height

Adjust working height on 100-NF model from 800 to 950 mm. On 200-M and 400-MS/A, working height adjusts from 920 to 970 mm. Note with Wheel Kit installed, working height is fixed at 950 mm for all models. (DownFlex® 100-NF shown with optional Central System Connector Kit).

DownFlex® Downdraft Tables

RECOMMENDED ACCESSORIES

GENERAL OPTIONS



Plasma Cutting Work Grid
Specially constructed work grid required for plasma cutting applications (maximum current 50 amps). The work grid consists of two frames with 13 bars each and two additional spark arrestors to be mounted over the existing ones in the downdraft table. The additional spark arrestors protect the existing spark arrestors against melting steel from the plasma cutting process.
Order 0040400020

Working Light Kit



Covered light fixture mounts to the back panel or backdraft panel of the downdraft table. Includes fluorescent lamp. Power cable connects at the rear of the downdraft table. The main switch of the downdraft table turns the working light on and off.
Order 0040300030

Mounting Bracket for Bench Vice



Universal mounting bracket for bench vice. To be connected to the standard work grid of a downdraft table. Bench vice not included. Cannot be used with Plasma Cutting Work Grid.
Order 0040400030

GENERAL OPTIONS 200-M and 400-MS/A Models Only



HEPA Filter Kit
Includes filter housing and HEPA filter. Mounts on the outlet of the downdraft table. HEPA rating is H12.
Order 0040000010

HEPA Filter

Replacement HEPA Filter.
Order 0040000030



Wheel Kit

Allows for easy movement of downdraft table. The working height of the downdraft table with wheel set installed is fixed to 950 mm.
Order 0040400040



Silencer/Outlet Duct

Reduces sound level of downdraft table. Also prevents dust from blowing up from the floor. The Silencer/Outlet Duct can be connected directly to the outlet of the downdraft table or to the HEPA Filter Kit. It is not suitable for connection to a duct system.
Order 0040100010



Dust Tray Kit

Lid to cover the dust tray underneath the main filter cartridges of a downdraft table for dust free removal. Kit includes zinc-plated steel lid, plastic bag, face mask and a pair of disposable gloves. The Dust Tray Kit is recommended for stainless steel welding applications.
Order 0040500010



Start/Stop Welding Current Sensor

Automatically switches the fan of a downdraft table on and off. Welding Current Sensor consists of a metal clamp with a built-in sensor. Can be used for all electric arc welding processes, including TIG (GTAW) welding. Not suitable for cutting or grinding applications. The cable connects at the rear of the downdraft table. For use with 400-MS/A model only.
Order 7900010350



Start/Stop Motion Activated Sensor

Automatic start/stop device based on movement sensor. Mounts on top of the back panel or backdraft panel of downdraft table. Fan of downdraft table starts running when sensor detects any movement above the work grid. When the work has stopped, the fan automatically switches off after a certain run-out period. The cable connects at the rear of the downdraft table. For use with 400-MS/A model only.
Order 0040300050



LongLife Filter

Replacement LongLife Filter. Includes two (2) oval shaped filters.
Order 0040000020



GENERAL OPTIONS 100-NF Model Only

Central System Connector Kit
Reducing piece allows connection of downdraft table to a 12 inch diameter extraction duct. Mounts on top of backdraft panel. Connector will not interfere with installing downdraft table against a wall.
Order 0050200040



Dust Container

Installs in dust collection tray of downdraft table. Lid and handle on container provide for dust-free removal. DownFlex® 100-NF has mounting space for up to two containers; one on each side of dust collection tray.
Order 0040100030

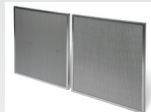

Spark Arrestor

Set of two spark arrestors. Installs in backdraft panel of DownFlex® 100-NF.
Order 0040100060

The operation of welding fume control equipment is affected by various factors including proper use and positioning of the equipment, maintenance of the equipment and the specific welding procedure and application involved. Worker exposure level should be checked upon installation and periodically thereafter to be certain it is within applicable OSHA PEL and ACGIH TLV limits.

**The Lincoln Electric Company
(Australia) PTY LTD**
35 Bryant Street Padstow 2211 Australia
1300 546 265 (Aus)
0800 728 720 (NZ)
www.lincolnelectric.com.au
www.lincolnelectric.co.nz

Your Lincoln Electric Distributor:

CUSTOMER ASSISTANCE POLICY

The business of The Lincoln Electric Company is manufacturing and selling high quality welding equipment, consumables, and cutting equipment. Our challenge is to meet the needs of our customers and to exceed their expectations. On occasion, purchasers may ask Lincoln Electric for advice or information about their use of our products. We respond to our customers based on the best information in our possession at that time. Lincoln Electric is not in a position to warrant or guarantee such advice, and assumes no liability, with respect to such information or advice. We expressly disclaim any warranty of any kind, including any warranty of fitness for any customer's particular purpose, with respect to such information or advice. As a matter of practical consideration, we also cannot assume any responsibility for updating or correcting any such information or advice once it has been given, nor does the provision of information or advice create, expand or alter any warranty with respect to the sale of our products. Lincoln Electric is a responsive manufacturer, but the selection and use of specific products sold by Lincoln Electric is solely within the control of, and remains the sole responsibility of the customer. Many variables beyond the control of Lincoln Electric affect the results obtained in applying these types of fabrication methods and service requirements.

Subject to Change - This information is accurate to the best of our knowledge at the time of printing.

LINCOLN®
ELECTRIC
THE WELDING EXPERTS®