

USER MANUAL

HYBRID SOLAR INVERTER/CHARGER

8.5KVA/11.0KVA 230Vac

Table Of Contents

ABOUT THIS MANUAL	1
Purpose	1
Scope	1
SAFETY INSTRUCTIONS	1
INTRODUCTION	2
Features	2
Basic System Architecture	2
PRODUCT OVERVIEW	3
INSTALLATION	4
Unpacking and Inspection	4
Preparation	4
Mounting the Unit	4
Battery Connection	5
AC Input/Output Connection	6
PV Connection	8
Final Assembly	9
Dry Contact Signal	10
OPERATION	11
Power ON/OFF	11
Operation and Display Panel	11
LCD Display	12
LCD Setting	12
LCD display description	21
Warning Indicator	27
BATTERY EQUALIZATION	28
SETTING FOR LITHIUM BATTERY	30
SPECIFICATIONS	33
Table 1 Line Mode Specifications	33
Table 2 Inverter Mode Specifications	34
Table 3 Charge Mode Specifications	35
Table 4 General Specifications	35
TROUBLE SHOOTING	36
Parallel Installation Guide	37
Instruction	37
Package Contents	37
Mounting the Unit	37
Wiring Connection	38
Parallel Operation in Single phase	40
Support 3-phase equipment	43
PV Connection	45
Commissioning	46
Trouble shooting	47

ABOUT THIS MANUAL

Purpose

This manual describes the assembly, installation, operation and troubleshooting of this unit. Please read this manual carefully before installations and operations. Keep this manual for future reference.

Scope

This manual provides safety and installation guidelines as well as information on tools and wiring.

SAFETY INSTRUCTIONS



WARNING: This chapter contains important safety and operating instructions. Read and keep this manual for future reference.

1. Before using the unit, read all instructions and cautionary markings on the unit, the batteries and all appropriate sections of this manual.
2. **CAUTION** --To reduce risk of injury, charge only deep-cycle lead acid type rechargeable batteries. Other types of batteries may burst, causing personal injury and damage.
3. Do not disassemble the unit. Take it to a qualified service center when service or repair is required. Incorrect re-assembly may result in a risk of electric shock or fire.
4. To reduce risk of electric shock, disconnect all wirings before attempting any maintenance or cleaning. Turning off the unit will not reduce this risk.
5. **CAUTION** – Only qualified personnel can install this device with battery.
6. **NEVER** charge a frozen battery.
7. For optimum operation of this inverter/charger, please follow required spec to select appropriate cable size. It's very important to correctly operate this inverter/charger.
8. Be very cautious when working with metal tools on or around batteries. A potential risk exists to drop a tool to spark or short circuit batteries or other electrical parts and could cause an explosion.
9. Please strictly follow installation procedure when you want to disconnect AC or DC terminals. Please refer to INSTALLATION section of this manual for the details.
10. Fuse is provided as over-current protection for the battery supply.
11. GROUNDING INSTRUCTIONS -This inverter/charger should be connected to a permanent grounded wiring system. Be sure to comply with local requirements and regulation to install this inverter.
12. NEVER cause AC output and DC input short circuited. Do NOT connect to the mains when DC input short circuits.
13. **Warning!!** Only qualified service persons are able to service this device. If errors still persist after following troubleshooting table, please send this inverter/charger back to local dealer or service center for maintenance.

INTRODUCTION

This is a multi-function inverter/charger, combining functions of inverter, MPPT solar charger and battery charger to offer uninterrupted power support with portable size. Its comprehensive LCD display offers user-configurable and easy-accessible button operation such as battery charging current, AC/solar charger priority, and acceptable input voltage based on different applications.

Features

1. Pure sine wave inverter
2. Inverter running without battery
3. Built-in MPPT solar controller
4. Configurable input voltage range for home appliances and personal computers via LCD setting
5. Configurable battery charging current based on applications via LCD setting
6. Configurable AC/Solar Charger priority via LCD setting
7. Compatible to mains voltage or generator power
8. Auto restart while AC is recovering
9. Overload/ Over temperature/ short circuit protection
10. Smart battery charger design for optimized battery performance
11. Cold start function

Basic System Architecture

The following illustration shows basic application for this inverter/charger. It also includes following devices to have a complete running system:

1. Generator or Utility.
2. PV modules (option)

Consult with your system integrator for other possible system architectures depending on your requirements.

This inverter can power all kinds of appliances in home or office environment, including motor-type appliances such as tube light, fan, refrigerator and air conditioner.

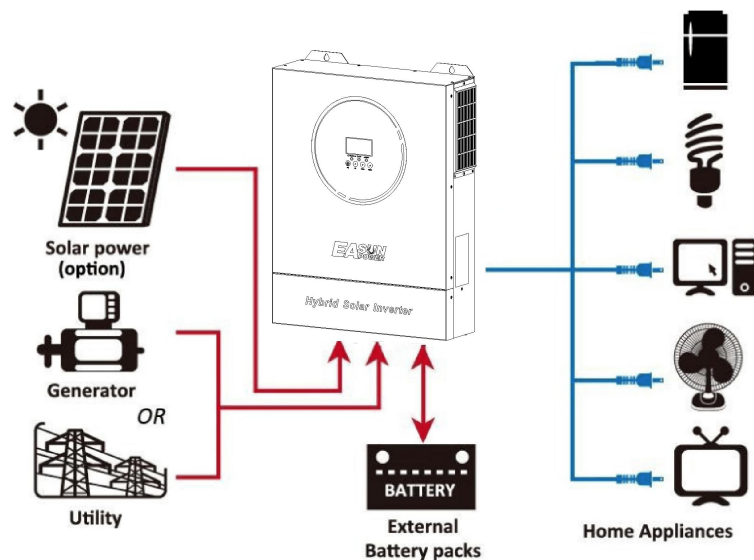
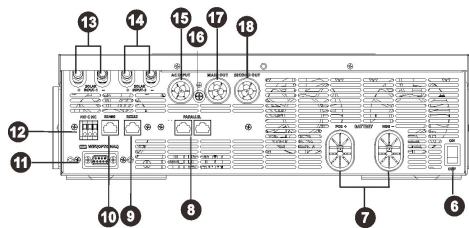
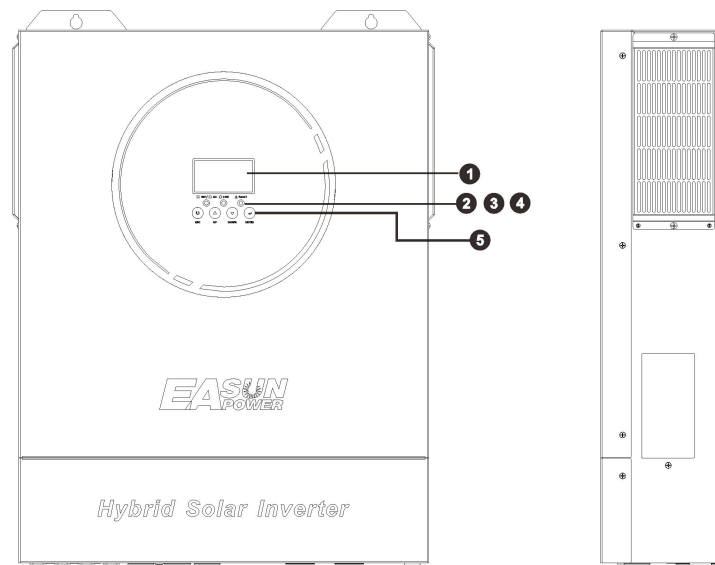

Figure 1 Hybrid Power System

PRODUCT OVERVIEW



1. LCD display
2. Status indicator
3. Charging indicator
4. Fault indicator
5. Function buttons
6. Power on/off switch
7. Battery negative/ positive outlet hole
8. Parallel communication port
(only for parallel model)
9. RS232 communication port (RJ45)
10. RS485 communication port (DJ45)
11. RS232 communication port (DB9)
12. Dry contact port
13. PV1 input
14. PV2 input
15. AC input
16. Grounding point
17. Main output
18. Second output

Note: RS232 communication port (DB9) and RS232 communication port (RJ45) can't be used simultaneously, only one can be used at the same time

INSTALLATION

Unpacking and Inspection

Before installation, please inspect the unit. Be sure that nothing inside the package is damaged. You should have received the following items inside of package:

1. The unit x 1
2. User manual x 1
3. PV connector x 4
4. Battery fuse x 1 (Only 11K)

Preparation

Before connecting all wirings, please take off bottom cover by removing four screws as shown below.

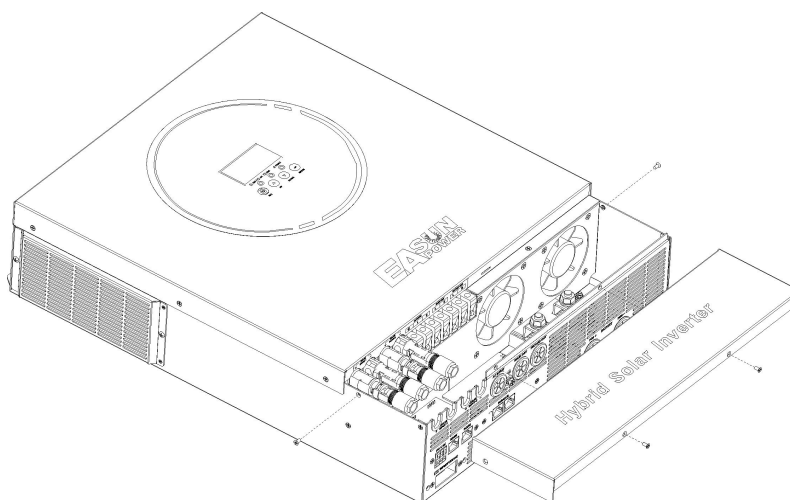

Mounting the Unit

Consider the following points before selecting where to install:

1. Do not mount the inverter on flammable construction materials.
2. Mount on a solid surface
3. Install this inverter at eye level in order to allow the LCD display to be read at all times.
4. The ambient temperature should be between 0°C and 55°C to ensure optimal operation.
5. The recommended installation position is to be adhered to the wall vertically.
6. Be sure to keep other objects and surfaces as shown in the right diagram to guarantee sufficient heat dissipation and to have enough space for removing wires.

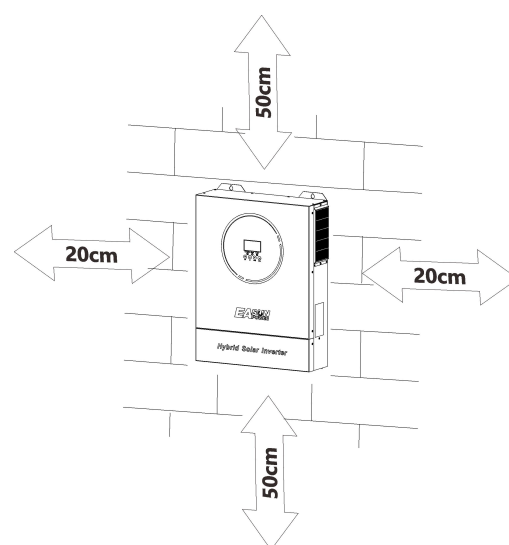

SUITABLE FOR MOUNTING ON CONCRETE OR OTHER NON-COMBUSTIBLE SURFACE ONLY.

Install the unit by screwing three screws. It's recommended to use M4 or M5 screws.

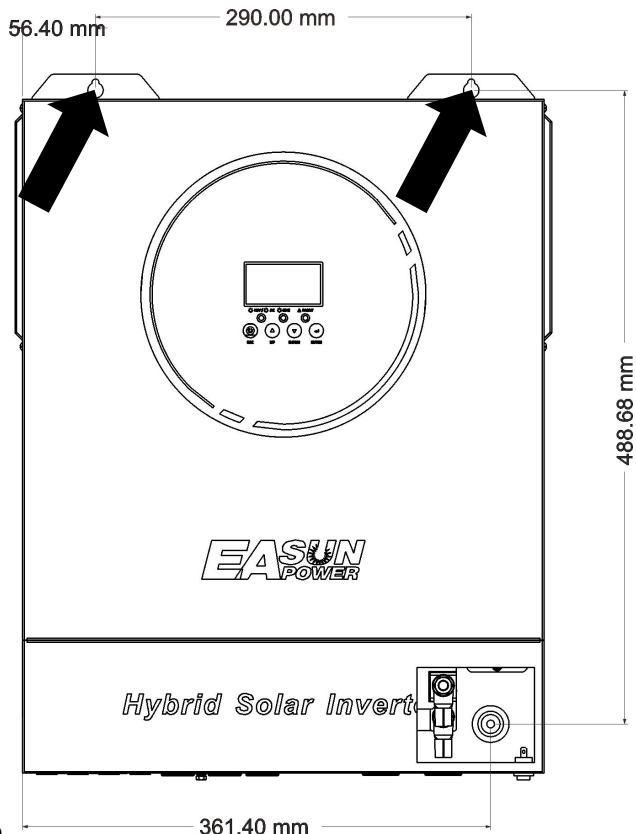

Battery Connection

CAUTION: For safety operation and regulation compliance, it's requested to install a separate DC over-current protector or disconnect device between battery and inverter. It may not be requested to have a disconnect device in some applications, however, it's still requested to have over-current protection installed. Please refer to typical amperage in below table as required fuse or breaker size.

WARNING! All wiring must be performed by a qualified personnel.

WARNING! It's very important for system safety and efficient operation to use appropriate cable for battery connection. To reduce risk of injury, please use the proper recommended cable

Recommended battery cable , Terminal size:

Model	Maximum Amperage	Battery capacity	Wire Size	Cable mm2	Terminal size(mm)			Torque value
					L	W	D	
8.5KVA	180A	400AH	4AWG*2	25	37	22	8.4	10~12 Nm
11.0KVA	220A	600AH	2AWG*2	38	37	22	8.4	10~12 Nm

Terminal size:

Please follow below steps to implement battery connection:

1. Make positive and negative cables based on recommended terminal size.
2. Connect all battery packs as units requires. It's suggested to use recommended battery capacity.
3. Insert battery cable flatly into battery connector of inverter and make sure the bolts are tightened with torque of 10-12Nm. Make sure polarity at both the battery and the inverter/charge is correctly connected and battery cables are tightly screwed to the battery connector.

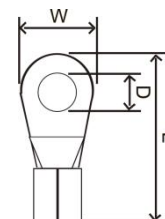

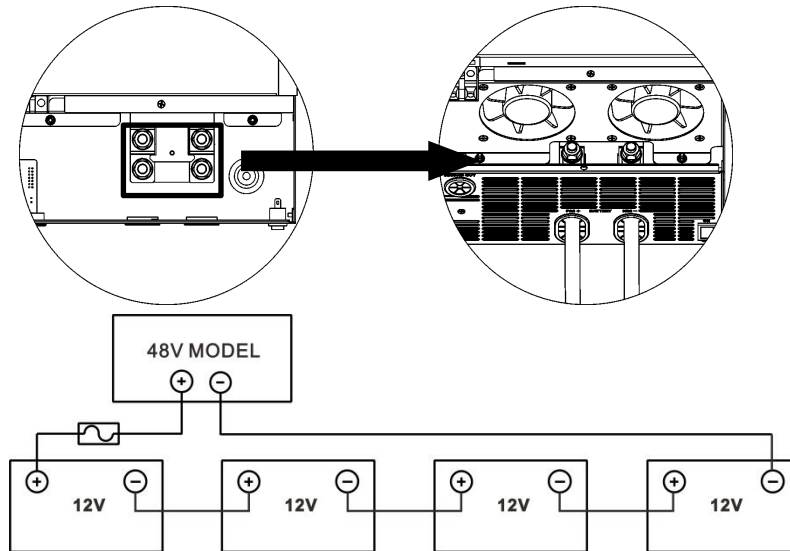

WARNING: Shock Hazard

Installation must be performed with care due to high battery voltage in series.



CAUTION!! Do not place anything between the flat part of the inverter terminal. Otherwise, overheating may occur.

CAUTION!! Do not apply anti-oxidant substance on the terminals before terminals are connected tightly.

CAUTION!! Before making the final DC connection or closing DC breaker/disconnector, be sure positive (+) must be connected to positive (+) and negative (-) must be connected to negative (-).

AC Input/Output Connection

CAUTION!! Before connecting to AC input power source, please install a **separate** AC breaker between inverter and AC input power source. This will ensure the inverter can be securely disconnected during maintenance and fully protected from over current of AC input. The recommended spec of AC breaker is 63A.

CAUTION!! There are two terminal blocks with "IN" and "OUT" markings. Please do NOT mis-connect input and output connectors.

WARNING! All wiring must be performed by qualified personnel.

WARNING! It's very important for system safety and efficient operation to use appropriate cable for AC input connection. To reduce risk of injury, please use the proper recommended cable size as below.

Suggested cable requirement for AC wires

Model	Gauge	Torque Value
All Model	6 AWG	1.2~ 1.4Nm

Please follow below steps to implement AC input/output connection:

1. Before making AC input/output connection, be sure to open DC protector or disconnector first.
2. Remove insulation sleeve 10mm for six conductors. And shorten phase L and neutral conductor N 3 mm.
3. Insert AC input wires according to polarities indicated on terminal block and tighten the terminal screws. Be sure to connect PE protective conductor (⊕) first.

⊕ → **Ground (yellow-green)**

L → **LINE (brown or black)**

N → **Neutral (blue)**

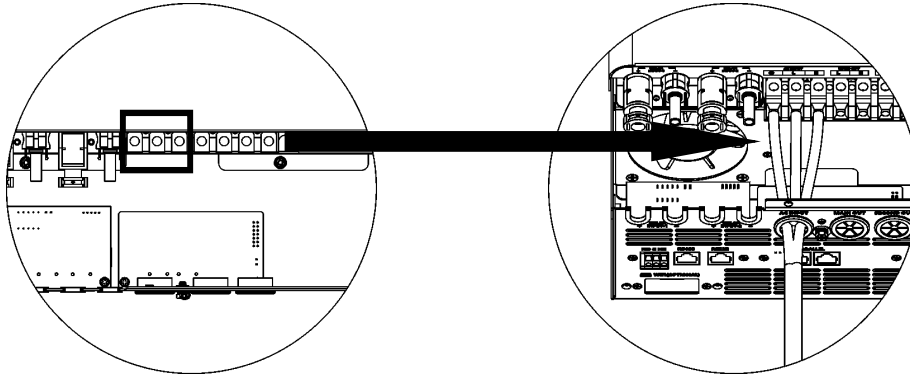

WARNING:

Be sure that AC power source is disconnected before attempting to hardwire it to the unit.

4. Then, insert AC output wires according to polarities indicated on terminal block and tighten terminal screws. Be sure to connect PE protective conductor (⊕) first.

⊕ → **Ground (yellow-green)**

L → **LINE (brown or black)**

N → **Neutral (blue)**

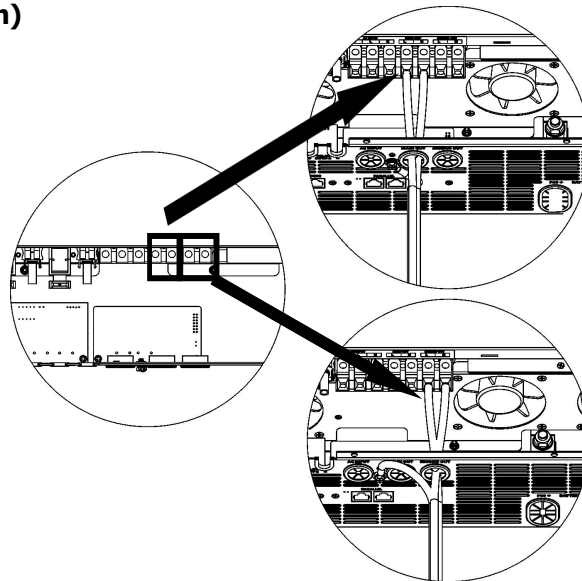

1. Make sure the wires are securely connected.

CAUTION: Important

Be sure to connect AC wires with correct polarity. If L and N wires are connected reversely, it may cause utility short-circuited when these inverters are worked in dual output operation.

CAUTION: Appliances such as air conditioner are required at least 2~3 minutes to restart because it's required to have enough time to balance refrigerant gas inside of circuits. If a power shortage occurs and recovers in a short time, it will cause damage to your connected appliances. To prevent this kind of damage, please check manufacturer of air conditioner if it's equipped with time-delay function before installation. Otherwise, this inverter/charger will trig overload fault and cut off output to protect your appliance but sometimes it still causes internal damage to the air conditioner.

PV Connection

CAUTION: Before connecting to PV modules, please install **separately** a DC circuit breaker between inverter and PV modules.

WARNING! All wiring must be performed by qualified personnel.

WARNING! It's very important for system safety and efficient operation to use appropriate cable for PV module connection. To reduce risk of injury, please use the proper recommended cable size as below.

Model	Typical Amperage	Cable Size	Torque
All Model	18A*2	10 AWG	1.4~1.6 Nm

PV Module Selection:

When selecting proper PV modules, please be sure to consider below parameters:

1. Open circuit Voltage (Voc) of PV modules not exceeds max. PV array open circuit voltage of inverter.
2. Open circuit Voltage (Voc) of PV modules should be higher than min. battery voltage.

Solar Charging Mode		
INVERTER MODEL	8.5KVA	11.0KVA
Max. PV Array Open Circuit Voltage	500VDC	
PV Array MPPT Voltage Range	60VDC~500VDC	
Max. PV INPUT CURRENT	18A*2	

Take the 450Wp and 550Wp PV module as an example. After considering above two parameters, the recommended module configurations are listed in the table below. The recommended module configurations are fit for PV1 or PV2, for example: PV1 is 8 pcs in serial and PV1 could be 8 pcs in serial too, total quantity of panels is 16pcs.

	SOLAR INPUT	Q'ty of panels	Total input power	Inverter Model
Solar Panel Spec. (reference) - 450Wp - Vmp: 34.67Vdc - Imp: 13.82A - Voc: 41.25Vdc - Isc: 12.98A	3 pcs in serial	3 pcs	1,350 W	All Model
	4 pcs in serial	4 pcs	1,800 W	
	5 pcs in serial	5 pcs	2,250 W	
	6 pcs in serial	6 pcs	2,700 W	
	7 pcs in serial	7 pcs	3,150 W	
	8 pcs in serial	8 pcs	3,600 W	
	9 pcs in serial	9 pcs	4,050 W	
	10 pcs in serial	10 pcs	4,500 W	
	11 pcs in serial	11 pcs	4,950 W	
	12 pcs in serial	12 pcs	5,400 W	
Solar Panel Spec. (reference) - 550Wp - Vmp: 42.48Vdc - Imp: 12.95A - Voc: 50.32Vdc - Isc: 13.70A	SOLAR INPUT	Q'ty of panels	Total input power	Inverter Model
	3 pcs in serial	3 pcs	1,650 W	All Model
	4 pcs in serial	4 pcs	2,200 W	
	5 pcs in serial	5 pcs	2,750 W	
	6 pcs in serial	6 pcs	3,300 W	
	7 pcs in serial	7 pcs	3,850 W	
	8 pcs in serial	8 pcs	4,400 W	
	9 pcs in serial	9 pcs	4,950 W	

PV Module Wire Connection:

Please follow below steps to implement PV module connection:

1. Remove insulation sleeve 10 mm for positive and negative conductors.
2. Check correct polarity of connection cable from PV modules and PV input connectors. Then, connect positive pole (+) of connection cable to positive pole (+) of PV input connector. Connect negative pole (-) of connection cable to negative pole (-) of PV input connector.

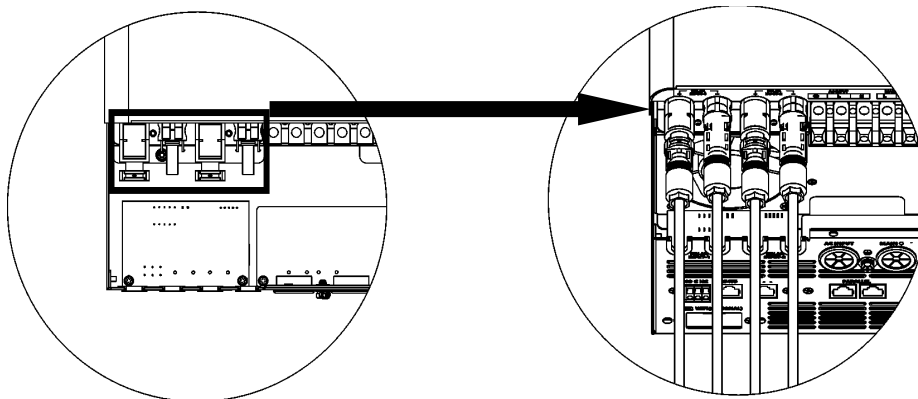
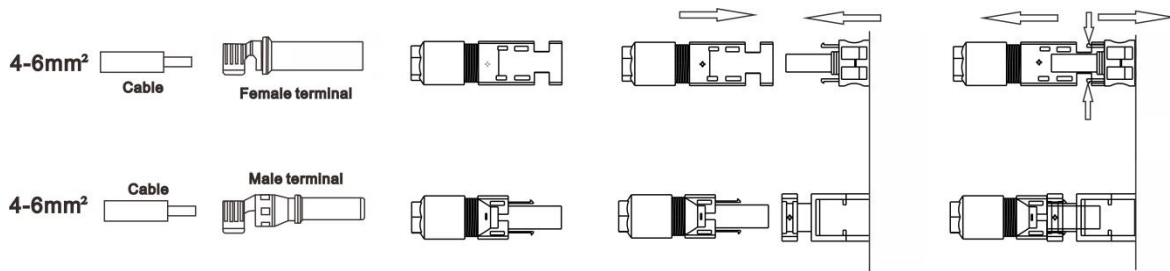
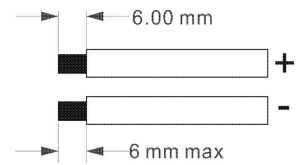

3. Make sure the wires are securely connected.

Final Assembly

After connecting all wirings, please put bottom cover back by screwing four screws as shown below.

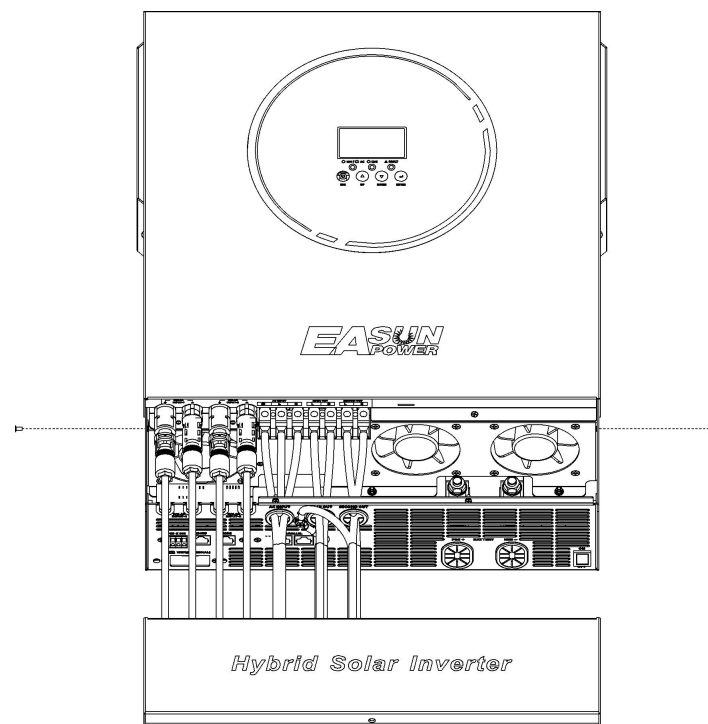

Dry Contact Signal

There is one dry contact (3A/250VAC) available on the rear panel. When program 16 of F0 group is set as "Model1", it could be used to deliver signal to external device when battery voltage reaches warning level. When program 16 of F0 is set as "Model2" and the unit is working in battery mode, it could be used to trigger the grounding box to connect neutral and grounding of AC output together.

Unit Status	Condition		Dry contact port: 		
			NC & C	NO & C	
Power Off	Unit is off and no output is powered.		Close	Open	
Power On	Output is powered from Utility.		Close	Open	
	Output is powered from Battery or Solar.	Program 1 of F1 set as SUB	Battery voltage or Soc < Low DC warning voltage or Soc	Open	Close
			Battery voltage or Soc > setting value program 5 of F2 or battery charging reaches floating stage	Close	Open
	Output is powered from Battery or Solar.	Program 1 of F1 is set as SBU	Battery voltage < Setting value program 5 of F2	Open	Close
Battery voltage > setting value program 6 of F2 or battery charging reaches floating stage			Close	Open	

When program 16 of F0 is set as "Model2":

Unit Status	Condition		Dry contact port: 	
			NC & C	NO & C
Power Off	Unit is off and no output is powered		Close	Open
Power On	Unit works in standby mode, line mode or fault mode		Close	Open
	Unit works in battery mode or power saving mode		Open	Close

OPERATION

Power ON/OFF

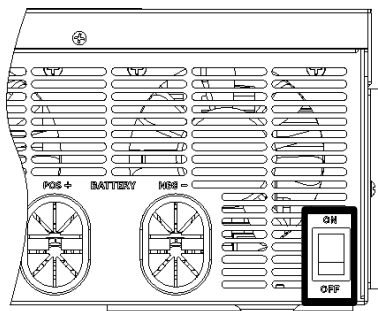

Once the unit has been properly installed and the batteries are connected well, simply press On/Off switch (located on the button of the case) to turn on the unit.

Operation and Display Panel

The operation and display panel, shown in below chart, is on the front panel of the inverter. It includes three indicators, four function keys and a LCD display, indicating the operating status and input/output power information.

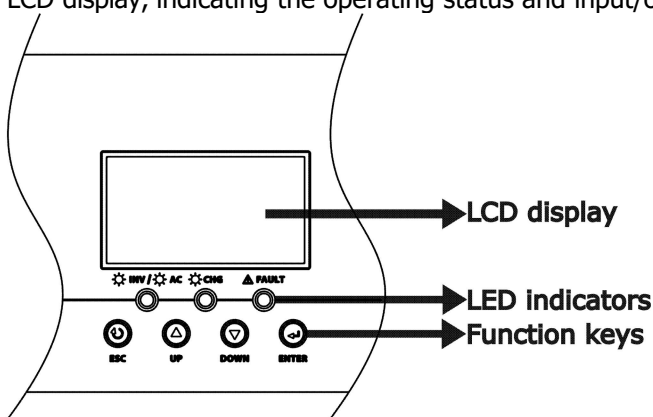

LED Indicator

LED Indicator		Messages	
☀️ AC / 🌙 INV	Green	Solid On	Output is powered by utility in Line mode.
		Flashing	Output is powered by battery or PV in battery mode.
☀️ CHG	Green	Solid On	Battery is fully charged.
		Flashing	Battery is charging.
⚠️ FAULT	Red	Solid On	Fault occurs in the inverter.
		Flashing	Warning condition occurs in the inverter.

Function Keys

Function Key	Description
ESC	To exit setting mode
UP	To go to previous selection
DOWN	To go to next selection
ENTER	To confirm the selection in setting mode or enter setting mode

LCD Display

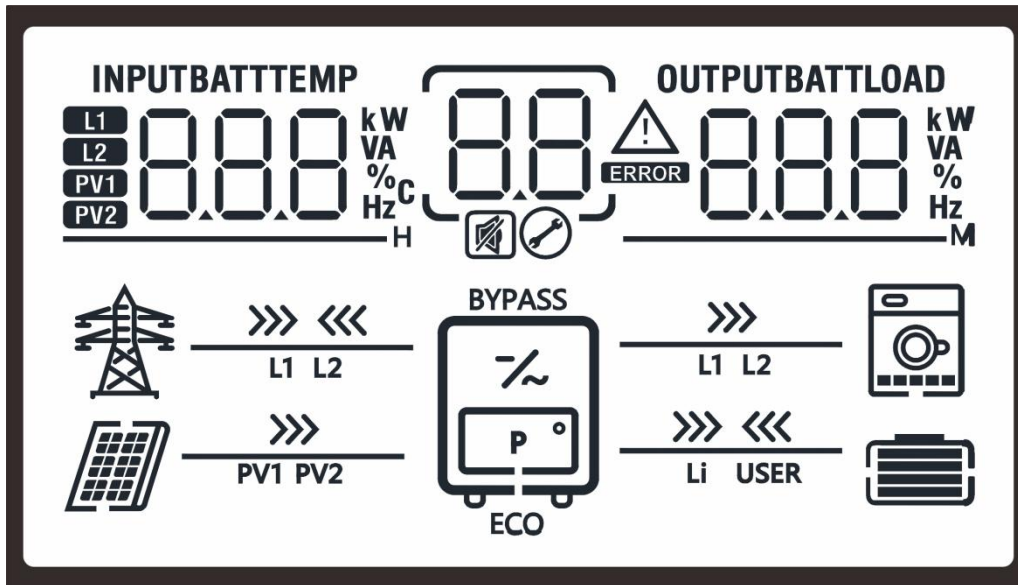

LCD Setting

1. Pressing and holding ENTER button for 3 seconds, the unit will enter setting groups mode.
2. Press "UP" or "DOWN" button to select setting groups. There are 5 groups setting menu include F0/F1/F2/F3/F4, press "ENTER" button to confirm the selection or ESC button to exit.

F0: Setting general parameters

F1: Setting AC output parameters

F2: Setting battery parameters

F3: Setting time parameters

F4: Setting systems parameters

3. Press "ENTER" button to confirm the selection groups or ESC button to return selection groups or exit.

Setting F0 Programs:

Program	Description	Selectable option	
01	AC input voltage range	Appliances (default) APL	If selected, acceptable AC input voltage range will be within 90-280VAC.
		UPS UPS	If selected, acceptable AC input voltage range will be within 170-280VAC.
		Generator GNE	If selected, acceptable AC input voltage range will be within 170-280VAC and compatible with generators. Note: Because generators are unstable, maybe the output of inverter will be unstable too.
02	Power saving mode enable/disable Note: The parallel system can only be disabled	Saving mode disable (default) SDS	If disabled, no matter connected load is low or high, the on/off status of inverter output will not be effected.
		Saving mode enable SEN	If enabled, the output of inverter will be off when connected load is pretty low or not detected.
03	Overload bypass: When enabled, the unit will transfer to line mode if overload occurs in battery mode. Note: The parallel system can only be enabled	Bypass disable BYD	Bypass enable (default) BYE
04	Auto restart when overload occurs	Restart disable LRD	Restart enable (default) LRE
05	Auto restart when over temperature occurs	Restart disable TRD	Restart enable (default) TRE
06	Auto bypass When selecting "auto", if the mains power is normal, it will automatically bypass, even if the switch is off.	manual(default) MAN	auto ATO
07	Auto return to default display screen	Return to default display screen (default) ESP	If selected, no matter how users switch display screen, it will automatically return to default display screen after no button is pressed for 1 minute.
		Stay at latest screen BEP	If selected, the display screen will stay at latest screen user finally switches.
08	Backlight control	Backlight on (default) LON	Backlight off LOF

09	Buzzer mode	Mode1 nd1	Buzzer mute
		Mode2 nd2	The buzzer sounds when the input source changes or there is a specific warning or fault
		Mode3 nd3	The buzzer sounds when there is a specific warning or fault
		Mode4(default) nd4	The buzzer sounds when there is a fault
10	Modbus ID Setting	Modbus ID Setting Range : 001(default)~247	
16	Dry contact mode Please check the function in chapter about "Dry Contact Signal"	Model1:(default) nd1	it could be used to deliver signal to external device when battery voltage reaches warning level.
		Model2: nd2	Allow neutral and grounding of AC output is connected together. This function is only available when the inverter is working with external grounding box. Only when the inverter is working in battery mode, it will trigger grounding box to connect neutral and grounding of AC output. Neutral and grounding of AC output is connected.
17	Allow neutral and grounding of AC output is connected together	Disable: Neutral and grounding of AC output is disconnected. (Default) d15	Enable: Neutral and grounding of AC output is connected. ENR
18	When multiple peaks appear in the PV power curve, this item can be set to perform MPPT scan maximum power	No scanning d15	Disable scanning
		Periodic scanning tin	Automatically scan the PV power curve every hour
		Power fluctuation scan POU	Every few minutes, a comparison of PV power will be conducted, and if the fluctuation exceeds $\pm 20\%$, a scan of the PV power curve will be triggered.
		Periodic/power fluctuation scan bth	Periodic scanning and Power fluctuation scan are effective simultaneously

Setting F1 Programs:

Program	Description	Selectable option	
01	Output source priority	SUB priority (default) SUB	Solar->Utility->Battery Solar energy is charged first and then power to the loads If solar energy is not sufficient to power all connected loads, Utility energy will supply power to the loads at the same time
		SBU priority SBU	Solar-> Battery ->Utility Solar energy provides power to the loads as first priority If solar energy is not sufficient to power all connected loads, battery energy will supply power to the loads at the same time. Utility provides power to the loads only when battery voltage drops to either low-level warning voltage or the setting point in program 05 of F2 group
		SUF priority SUF	Solar->Utility->Battery If solar energy is sufficient to all connected loads and charge battery, the solar energy could feedback to the grid If solar energy is not sufficient to power all connected loads, utility energy will supply power to the loads at the same time
02	AC output mode	S10	Single: This inverter is used in single phase application.
		PARL	Parallel: This inverter is operated in parallel system.
		3P1	The inverter is operated in L1 phase in 3-phase application
		3P2	The inverter is operated in L2 phase in 3-phase application
		3P3	The inverter is operated in L3 phase in 3-phase application
03	Output voltage	230V(default) The available voltage settings are 220V, 230V, 240V	
04	Output frequency	50Hz(default) The available frequency settings are 50Hz and 60Hz	

06	Salve output source priority The priority is available after setting application period, the units will turn to salve priority in the setting period from main priority	OFF(default) OFF	Turn off salve output source priority
		SUB priority SUB	The function is the same as in program 01 of F1
		SBU priority SBU	
		SUF priority SUF	
07	Start timer setting for salve output source priority - Hours setting	00(default) The setting range is from 00 to 23 of every day	
08	Start timer setting for salve output source priority - Minutes setting	00(default) The setting range is from 00 to 59 of every hour	
09	End timer setting for salve output source priority - Hours setting	00(default) The setting range is from 00 to 23 of every day	
10	End timer setting for salve output source priority - Minutes setting	00(default) The setting range is from 00 to 59 of every hour	
11	second output (OP2) control Note: Only available in single system	Enable (default) ON If selected parallel mode, the parameter is fixed at 'Disable'.	Second output (OP2) is allowed
		Disable OFF	Second output (OP2) is forbidden
12	Setting the second output (OP2) overload warning point Note: Only available in single system	Set the OP2 overload warning point. If the set value is exceeded, 3D warning will be displayed. Setting range is from 10% to 100% and the default setting is 50%	
13	Setting the timer to turn on second output (OP2) - Hours setting Note: Only available in single system	00(default)	If you set the time from 00 to 23, OP2 will be always on. If you set the time to 07 to 13, OP2 will be turned on from 7:00 to 13:00. During this period, OP2 will be turned off if battery voltage reaches the setting value in program 08 of F2.
14	Setting the timer to turn off second output (OP2) - Hours setting Note: Only available in single system	23(default) Setting range is from 00 to 23	

Setting F2 Programs:

Program	Description	Selectable option	
01	Battery type	AGM	AGM (default)
		FLD	Flooded
		USE	User-Defined If "User-Defined" is selected, battery charge voltage and low DC cut-off voltage can be set up in program03/04/08 of F2
		L12	Support PYLON US2000 Protocol (3.5 Version)
		L14	Standard communication Protocol 2 from inverter supplier
		L16	If "LIB" is selected, the battery default value is fit for lithium battery without communication battery charge voltage and low DC cut-off voltage can be set up in program03/04/08 of F2
02	Charger source priority: To configure charger source priority	If this inverter/charger is working in Line, Standby or Fault mode, charger source can be programmed as below:	
		Solar first S0F	Solar energy will charge battery as priority. Utility will charge battery only when solar energy is not available
		Solar and Utility (default) SNU	Solar energy and utility will charge battery at the same time
		Only Solar O50	Solar energy will be the only charger source no matter utility is available or not
		Solar residual S0T	Solar energy will support all connected loads as first priority, the residual energy will charge battery
03	Bulk charging voltage (C.V voltage)	If self-defined or LIB is selected in program 01 of F2, this program can be set up	
		56.4V(default) If program 01 of F2 is not LIB, the default is 56.4V and setting range is from value of program 04 of F2 to 62V; If program 01 of F2 is LIB, the default is 56.4V and setting range is from value of program 04 of F2 to 58V	

04	Floating charging voltage	If self-defined or LIB is selected in program 01 of F2, this program can be set up	
		If program 01 of F2 is not LIB, the default setting is 54.0V and setting range is from 48.0V to the value of program 03 of F2 If program 01 of F2 is LIB, the default setting is 56.4V and setting range is from 48.0V to the value of program 03 of F2	
05	Setting voltage or Soc point back to utility source when selecting "SBU priority".	Lithium battery without communication	If program 01 of F2 is not LIB, the default setting is 46.0V and setting range is as follow: Max[44V, 07 of F2 +0.1V]~Min[06 of F2-0.1V,57.2V] If program 01 of F2 is LIB, the default setting is 52.0V and setting range is as follow: Max[44V, 07 of F2+0.1V]~Min[06 of F2-0.1V,57.2V]
		Lithium battery with communication	Default :50% setting range is from value of program 07 of F2+1% to 50%
06	Setting voltage point back to battery mode when selecting "SBU priority" in program 01(F1).	Battery fully charged (default) FUL	setting is battery fully charged and setting range is as follow: Max[48V, 05 of F2+0.1V]~ [03 of F2 - 0.5V or Full]
		Lithium battery with communication	Default 95% Setting range is from 60% to 100%
07	Setting cut off voltage point or SOC percentage on the Main output (OP1)	Lithium battery without communication	If program 01 of F2 is not LIB, the default is 44.0V, setting range is from program 08 of F2 to Min [05 of F2-0.1V , 54V] If program 01 of F2 is LIB, the default is 51.9V, setting range is as from 08 of F2 to Min [05 of F2-0.1V , 54V]
		Lithium battery with communication	Default 22% Setting range is from program 08 of F2 to Min[05 of F2 - 1%,30%]
08	Setting cut off voltage point or SOC percentage on the second output (OP2) Note: Only available in single system	Lithium battery without communication	If program 5 is not LIB, the default is 42.0V, setting range is from 40v~Min[07 of F2,54V].If selected parallel mode, this parameter is fixed at 40v. If program 5 is LIB, the default is 50.0V, setting range is from 40v~Min[07 of F2,54V]
		Lithium battery with communication	Default 20%.If selected parallel mode, this parameter is fixed at 3%. Setting range is from 3% to program 07 of F2
09	Maximum charging current: To configure total charging current for solar and utility chargers. (Max. charging current = utility charging current + solar charging current)	Single mode:80A (default) Parallel mode:30A (default)	8.5KW Model: If selected, acceptable charging current range will be within 10-140A, but it shouldn't be less than the AC charging current(program 10 of F2) 11.0KW Model: If selected, acceptable charging current range will be within 10-160A, but it shouldn't be less than the AC charging current (program 10 of F2)
10	Maximum utility charging current	Single mode:60A (default) Parallel mode:30A (default)	If selected, acceptable charging current range will be within 5-120A, but the max setting value must be less than the value of program 09 of F2

11	Slave charger source priority The priority is available after setting application period, the units will turn to slave priority in the setting period from main priority	OFF(default) OFF	Turn off slave charger source priority
		Solar first SOF	The function is the same as in program 02 of F2 group
		Solar and Utility (default) SNU	
		Only Solar OSO	
		Solar residual SOR	
12	Start timer setting for slave charger source priority - Hours setting	00(default) The setting range is from 00 to 23 of every day	
13	Start timer setting for slave charger source priority - Minutes setting	00(default) The setting range is from 00 to 59 of every hour	
14	End timer setting for slave output charger priority - Hours setting	00(default) The setting range is from 00 to 23 of every day	
15	End timer setting for slave charger source priority - Minutes setting	00(default) The setting range is from 00 to 59 of every hour	
16	Bulk charging time (C.V stage)	Automatically (Default): AUT	If selected, inverter will judge this charging time automatically
		5 min 005	The setting range is from 5 min to 900 min. Increment of each click is 5 min
		900 min 900	
		If "User-Defined" or "LIB" is selected in program 01 of F2 group, this program can be set up	

17	Battery equalization	Battery equalization EEN	Battery equalization disable (default) Ed5
		If "Flooded" or "User-Defined" is selected in program 01 of F2, this program can be set up	
18	Battery equalization voltage	Default setting is 58.4V Setting range is floating voltage(program 04 of F2)~ 62V	
19	Battery equalized time	60min (default) Setting range is from 0min to 900min. Increment of each click is 5min	
20	Battery equalized timeout	120min (default) Setting range is from 0min to 900 min. Increment of each click is 5 min	
21	Equalization interval	30days (default) 30d	Setting range is from 1 to 90 days. Increment of each click is 1 day
		If equalization function is enabled in program 17 of F2, this program can be set up. If "Enable" is selected in this program, it's to activate battery equalization immediately and LCD main page will show "E9". If "Disable" is selected, it will cancel equalization function until next activated equalization time arrives based on program 21 of F2 setting. At this time, "E9" will not be shown in LCD main page	
22	Equalization activated immediately	Enable AEN	Disable (default) Ad5
		If equalization function is enabled in program 17 of F2, this program can be set up. If "Enable" is selected in this program, it's to activate battery equalization immediately and LCD main page will show "E9". If "Disable" is selected, it will cancel equalization function until next activated equalization time arrives based on program 21 of F2 setting. At this time, "E9" will not be shown in LCD main page	
23	Manual activate the lithium battery setting	Disable(default) nop	Default: disable activation
		Active Act	When program 01 of F2 is selected "User-Defined" or "LIB" or "Lix" as lithium battery, when the battery is not detected, if you want to activate the lithium battery at a time, you could select it
24	Automatic activation for lithium battery	nAL	Default: disable activation
		Auto Ato	When program 01 of F2 is selected "Lix" as lithium battery, when the battery is not detected, the unit or PV will activate automatically the lithium battery at a time. If you want to activate automatically the lithium battery, you must restart the unit.
25	Max battery discharge current setting	OFF(Default) off	When the battery discharge current more than the setting value, the unit will stop discharging and go to bypass mode or standby mode. The setting range is from 50 to 500
26	lithium battery activation time	When lithium battery activation function is available, the activation time could be set, the setting range is 6s~300s,the default time is 6s;	

Setting F3 Programs:

Program	Description	Selectable option	
01	Time setting –Year	000;00 1..099	For year setting, the range is from 00 to 99.
02	Time setting–Month	00 1;002...0 12	For month setting, the range is from 1 to 12.
03	Time setting–Day	00 1;002...03 1	For day setting, the range is from 1 to 31.
04	Time setting –Hour	000;00 1..023	For hour setting, the range is from 0 to 23.
05	Time setting –Minute	000;00 1..059	For minute setting, the range is from 0 to 59.
06	Time setting –Second	000;00 1..059	For second setting, the range is from 0 to 59.

Setting F4 Programs:

Program	Description	Selectable option	
01	Reset all stored data of PV generated power and output load energy	Reserve data(default) No	Reset generated energy data YES

LCD display description

The LCD display information will be switched in turns by pressing "UP" or "DOWN" key. all of information could be show in 1/2/3 area of LCD

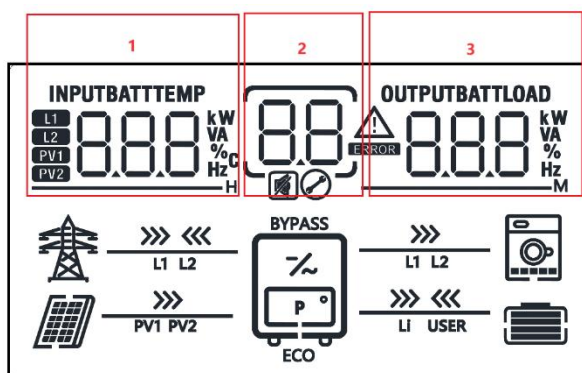

LCD display information			
Item	1 area data	3 area data	For Example
1	Input voltage	Output voltage	Input Voltage=220V, output voltage=220V (Default Display Screen)

2	Input frequency	Output frequency	<p>Input frequency=50Hz Output frequency=50Hz</p>
3	Total output active power	Total output apparent power	<p>Active power=3.02KW Apparent power=4.0KVA</p>
4	Output L1 apparent power	Output L1 active power	
5	Output L2 apparent power	Output L2 active power	
6	Input active power	PV feedback power	<p>active power=800w feedback power=0w</p>
7	Battery voltage	Load percentage	<p>Battery voltage=50V Load percentage=80%</p>
8	Charging power	Charging current	<p>Total charging power=1.8KW Charging current=36A Icon AC and PV is light show that AC grid and PV charging battery at the same time</p>

9	Total PV power	Discharge current	<p>PV power=8.6KW Battery discharge current is 0 A</p>
10	PV1 power	PV2 power	<p>PV1 power =4.5kw PV2 power =4.3kw</p>
11	PV1 voltage	PV1 current	<p>PV voltage=360V PV current=12A</p>
12	PV2 voltage	PV2 current	<p>PV voltage=320V PV current=13A</p>
16	DAY	Generation power/day	<p>Generation power/day=10KWh</p>
17	MON	Generation power /month	<p>Generation power /month=310KWh</p>
18	YEA	Generation power /year	<p>Generation power /year=3.6mWh</p>
19	TTL	Total generation power	<p>Total generation power=13.6mWh</p>

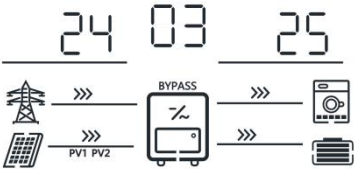
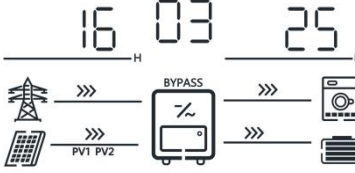
20	Year	month	day	2024/03/25 
21	Hour	second	minute	16:25 03s 

Only communication between the inverter and battery is successful, communication successful icon LI will be flashing, there is some information showing on the LCD

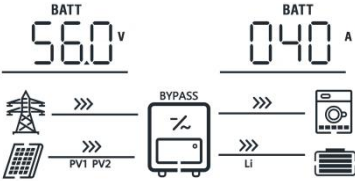
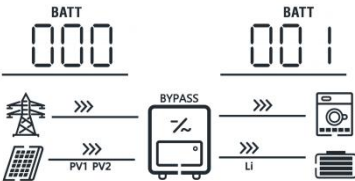
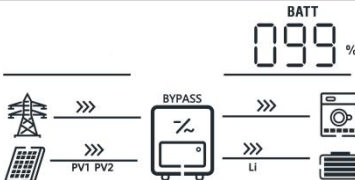
Item	1 Area data	3 Area data	For Example
13	Max lithium battery charging voltage	Max lithium battery charging current	
14		xx1 : Indicating that lithium battery charging is prohibited; x1x : Indicating that the lithium battery is prohibited; 1xx : Indicating that the lithium battery requires forced charging	
15		Lithium battery SOC(%)	

Other LCD display information

Please press and hold the button "Down" for a long time on main menu page, you could see the follow information.

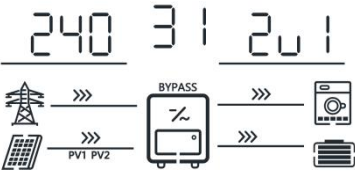
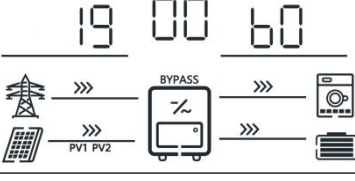
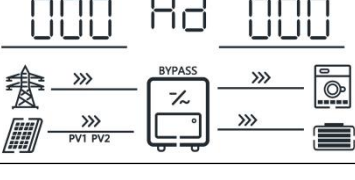
Item	1 Area data	2 Area data	2 Area data	For Example
1	Software Version part1	Software Version Part2	Software Version Part3	
2	Model code Version part1	Model code Version Part2	Model code Version Part3	
3	CPU type	HD	Hardware Version	

Fault Reference Code

There are seven groups about fault code, a fault code consist of group code and number, group code is first and number is last, such as C0.

A: Inverter group fault code

B: battery group fault code

















C: PV group fault code









D: Output group fault code

E: Parallel group fault code

F: Other group fault code

G: Grid group fault code

Fault Code	Fault Event	Icon on
A0	Output short circuited.	
A1	Output voltage is too high.	
A2	Over current or surge	
A3	Over DC voltage in AC output	
A4	Inverter current offset is too high	
A5	Output voltage is too low	
A6	Inverter negative power	
B0	Battery voltage is too high	
B1	DCDC over current	
B2	DC/DC current offset is too high	
C0	PV over current	
C1	PV over voltage	
C2	PV1 current offset is too high	
C3	PV2 current offset is too high	
D0	Overload time out	
D1	Op current offset is too high	
D2	Op2 current offset is too high	

F0	Over temperature of inverter module	
F1	Over temperature of PV module	
F2	Over temperature of DCDC module	
F3	Bus voltage is too high	
F4	Bus soft start failed	
F5	Bus voltage is too low	
F6	Hardware incompatibility	
F7	Screen communication abnormality	

Warning Indicator

There are seven groups about warning code, a warning code consist of group code and number, number is first and group code is last, such as 0B.

A: Inverter group fault code

B: battery group fault code

C: PV group fault code

D: Output group fault code

E: Parallel group fault code

F: Other group fault code

G: Grid group fault code

Warning Code	Warning Event	Audible Alarm	Icon flashing
0B	Battery low	Beep once every second	
1B	Battery is not connected	None	
2B	Battery equalization	None	
3B	Battery low and it isn't up to the setting value of program 06 of F2 group	Beep twice every 3 seconds	
4B	Lithium battery communication is abnormal	Beep once every 0.5 second	
5B	Battery discharge overcurrent	None	
1C	PV energy is too weak	Beep twice every 3 seconds	
0D	Overload	Beep once every 0.5 second	
1D	Output power derating	Beep twice every 3 seconds	
3D	The load exceeds the set value of program 12 of F1	None	
0F	Temperature is too High	Beep three times every second	

BATTERY EQUALIZATION

Equalization function is added into charge controller. It reverses the buildup of negative chemical effects like stratification, a condition where acid concentration is greater at the bottom of the battery than at the top. Equalization also helps to remove sulfate crystals that might have built up on the plates. If left unchecked, this condition, called sulfation, will reduce the overall capacity of the battery. Therefore, it's recommended to equalize battery periodically.

1. How to Apply Equalization Function

You must enable battery equalization function in monitoring LCD setting program 17 of F2 first. Then, you may apply this function in device by either one of following methods:

1. Setting equalization interval in program 21 of F2.
2. Active equalization immediately in program 22 of F2.

2. When to Equalize

In float stage, when the setting equalization interval (battery equalization cycle) is arrived, or equalization is active immediately, the controller will start to enter Equalize stage.

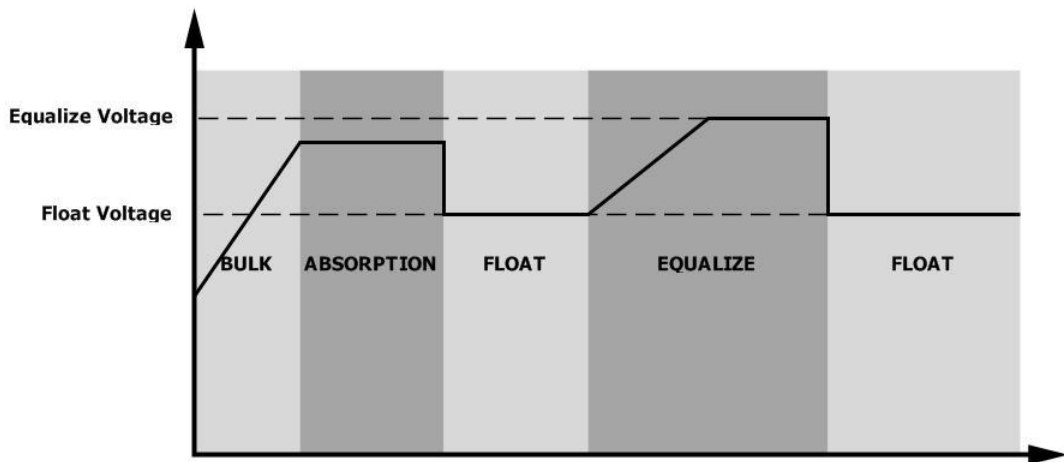

3. Equalize charging time and timeout

In Equalize stage, the controller will supply power to charge battery as much as possible until battery voltage raises to battery equalization voltage. Then, constant-voltage regulation is applied to maintain battery voltage at the battery equalization voltage. The battery will remain in the Equalize stage until setting battery equalized time is arrived.

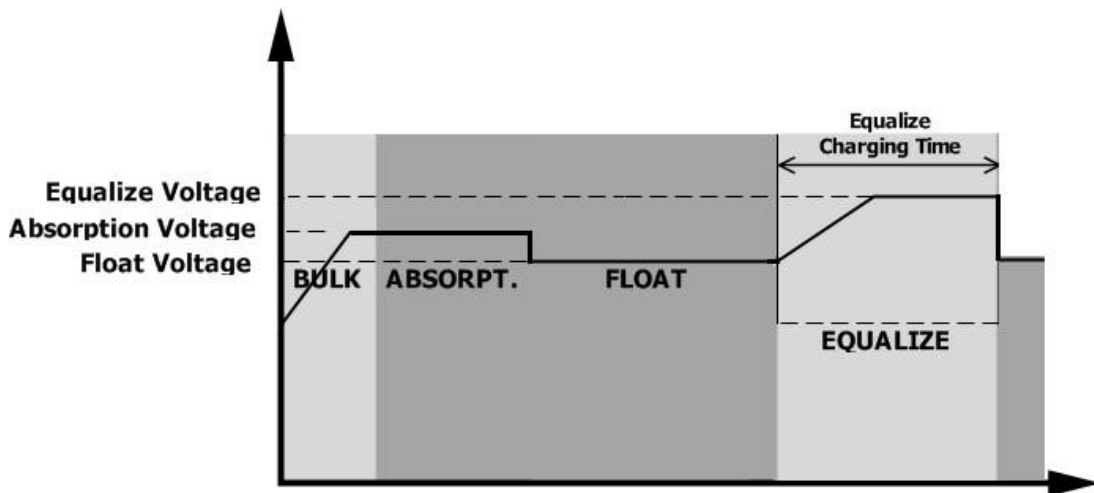

However, in Equalize stage, when battery equalized time is expired and battery voltage doesn't rise to battery equalization voltage point, the charge controller will extend the battery equalized time until battery voltage achieves battery equalization voltage. If battery voltage is still lower than battery equalization voltage when battery equalized timeout setting is over, the charge controller will stop equalization and return to float stage.

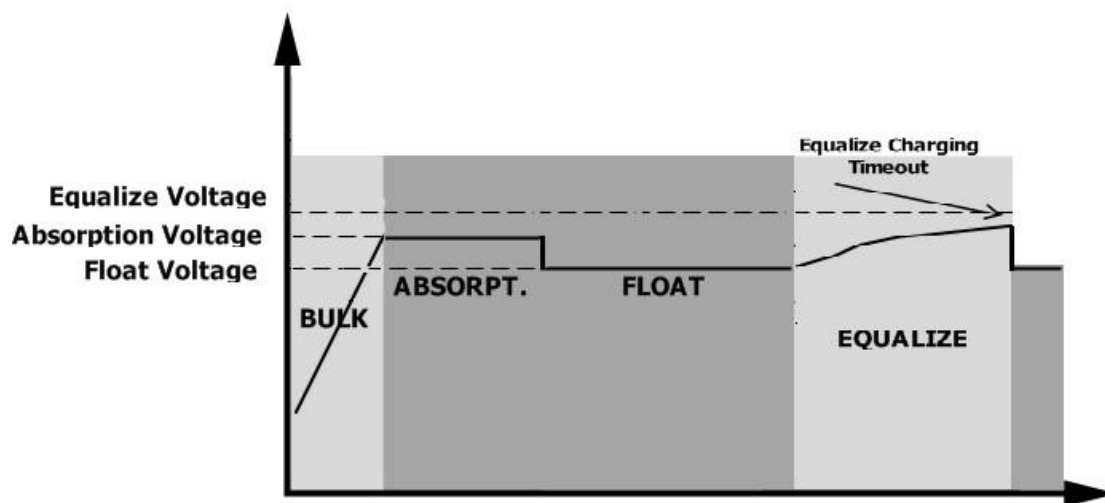

SETTING FOR LITHIUM BATTERY

Lithium Battery Connection

If choosing lithium battery for the inverter, you are allowed to use the lithium battery only which we have configured. There're two connectors on the lithium battery, RS485 port of BMS and power cable.

Please follow below steps to implement lithium battery connection:

- 1). Assemble battery terminal based on recommended battery cable and terminal size (same as Lead acid, see section Lead-acid Battery connection for details).
- 2). Connect the end of RS485 port of battery to BMS(RS485) communication port of inverter.

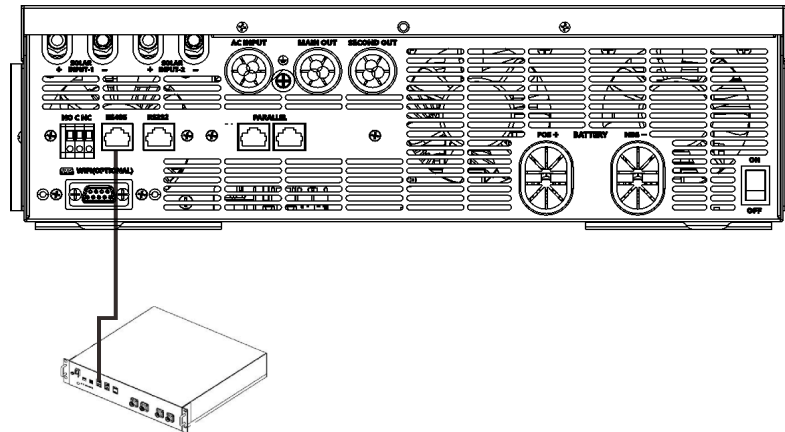

Lithium battery communication and setting

if choosing lithium battery, make sure to connect the BMS communication cable between the battery and the inverter. This communication cable delivers information and signal between lithium battery and the inverter. This information is listed below:

- Re-configure charging voltage, charging current and battery discharge cut-off voltage according to the lithium battery parameters.
- Have the inverter start or stop charging according to the status of lithium battery.

Connect the end of RS485 of battery to RS485 communication port of inverter

Make sure the lithium battery RS485 port connects to the inverter is Pin to Pin, the communication cable is inside of package and the inverter RS485 port pin assignment shown as below:

Pin number	RS485 Port
PIN1	RS485-B
PIN2	RS485-A
PIN7	RS485-A
PIN8	RS485-B

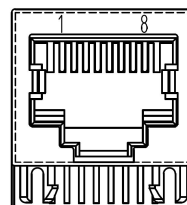

Setting for PYLON US2000 lithium battery

1. PYLONTECH US2000 lithium battery setting:

Dip Switch: There are 4 Dip Switches that sets different baud rate and battery group address. If switch position is turned to the "OFF" position, it means "0". If switch position is turned to the "ON" position, it means "1".

Dip 1 is "ON" to represent the baud rate 9600.

Dip 2, 3 and 4 are reserved for battery group address.

Dip switch 2, 3 and 4 on master battery (first battery) are to set up or change the group address.

NOTE: "1" is upper position and "0" is bottom position.

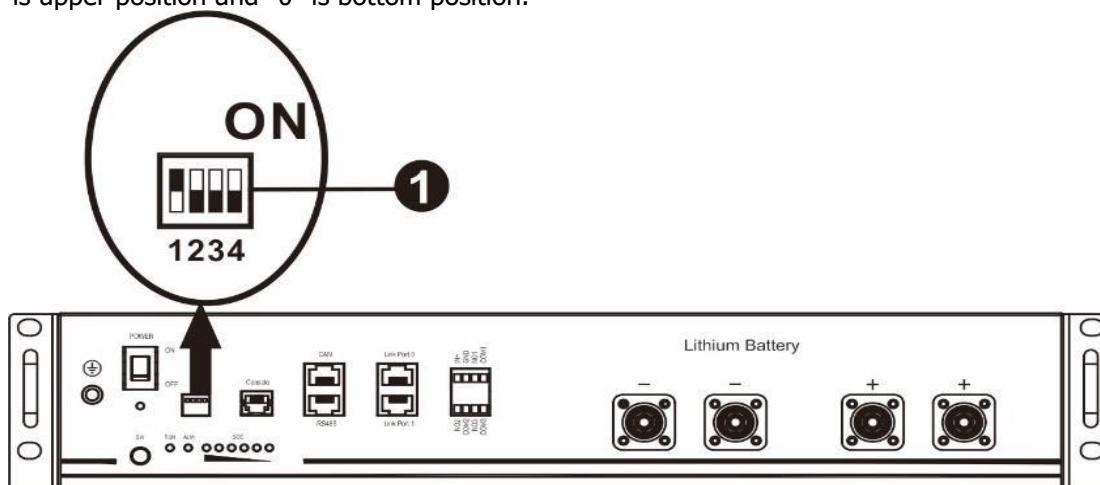

2. Process of install

Step 1. Use the RS485 cable to connect inverter and Lithium battery.

Step 2. Switch on Lithium battery.

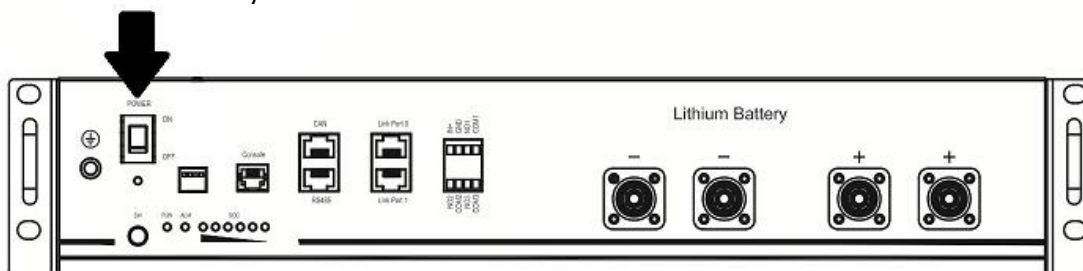

Step 3. Press more than three seconds to start Lithium battery, power output ready.

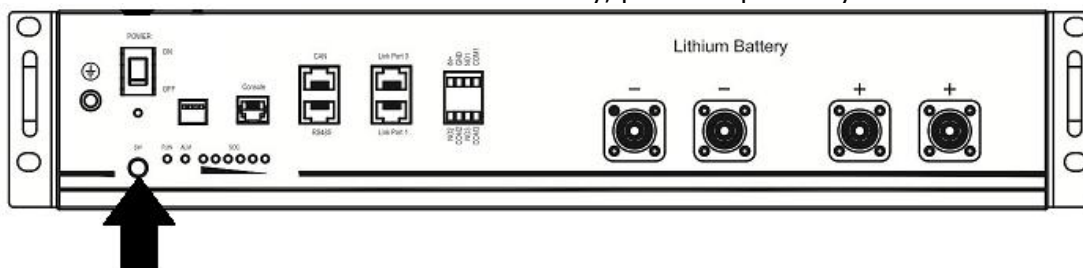

Step 4. Turn on the inverter.

Step 5. Be sure to select battery type as "Li2" in LCD program 5.

If communication between the inverter and battery is successful, the battery icon  on LCD display will light

Setting for lithium battery without communication

This suggestion is used for lithium battery application and avoid lithium battery BMS protection without communication, please finish the setting as follow:

Recommended method 1: Set battery type as "LIB " in program 01 of F2;

Recommended method 2: Setting as follow:

Before starting setting, you must get the battery BMS specification:

A. Max charging voltage

B. Max charging current

C. Discharging protection voltage

2. Set battery type as "LIB " in program 01 of F2;

3. Set C.V voltage as Max charging voltage of BMS-0.5V in program 03 of F2;

4. Set floating charging voltage as C.V voltage in program 03 of F2;

5. Set Low DC cut-off voltage \geq discharging protection voltage of BMS+3V;

6. Set Max charging current in program 09 of F2 which must be less than the Max charging current of BMS.

7. Setting voltage point back to utility source when selecting "SBU priority" in program 05 of F2.

The setting value must be \geq Low DC cut-off voltage+2V, or else the inverter will have a warning as battery voltage low.

Remark:

1. you'd better to finish setting without turn on the inverter(just let the LCD show, no output);

2. when you finish setting, please restart the inverter.

SPECIFICATIONS

Table 1 Line Mode Specifications

INVERTER MODEL	8.5KVA	11.0KVA
Input Voltage Waveform	Sinusoidal (utility or generator)	
Nominal Input Voltage	230Vac	
Low Loss Voltage	170Vac±7V (UPS) 90Vac±7V (Appliances)	
Low Loss Return Voltage	180Vac±7V (UPS); 100Vac±7V (Appliances)	
High Loss Voltage	280Vac±7V	
High Loss Return Voltage	270Vac±7V	
Max AC Input Voltage	300Vac	
Nominal Input Frequency	50Hz / 60Hz (Auto detection)	
Low Loss Frequency	40±1Hz	
Low Loss Return Frequency	42±1Hz	
High Loss Frequency	65±1Hz	
High Loss Return Frequency	63±1Hz	
Output Short Circuit Protection	Battery mode: Electronic Circuits	
Efficiency (Line Mode)	>95% (Rated R load, battery full charged)	
Transfer Time	10ms typical (UPS); 20ms typical (Appliances)	
<p>Output power derating: When AC input voltage drops to 95V or 170V depending on models, the output power will be derated.</p>		
<p>Output power derating: When battery voltage drops to 50.5V(8.5K)/ 55.0V(11K), the output power will be derated.</p>	<p>8.5KW Output power derating</p> <p>11.0 KW Output power derating</p>	

Table 2 Inverter Mode Specifications

INVERTER MODEL	8.5KVA	11.0KVA
Rated Output Power	8.5KVA/8.5KW	11.0KVA/11.0KW
Parallel Capability	YES, 6units	YES, 6units
Dual output function	Yes Only available in single system	Yes Only available in single system
Max.main output power	8.5KVA/8.5KW	11.0KVA/11.0KW
Max.second output power	5.0KVA/5.0KW	5.5KVA/5.5KW
Output Voltage Waveform	Pure Sine Wave	
Output Voltage Regulation	230Vac±5%	
Output Frequency	60Hz or 50Hz	
Peak Efficiency	94%	
Overload Protection	5.5s@≥140% load; 10.5s@100%~140% load	
Surge Capacity	2* rated power for 5 seconds	
Nominal DC Input Voltage	48Vdc	
Cold Start Voltage	46.0Vdc	
Low DC Warning Voltage Just for AGM and Flooded @ load < 20% @ 20% ≤ load < 50% @ load ≥ 50%	44.0Vdc 42.8Vdc 40.4Vdc	
Low DC Warning Return Voltage Just for AGM and Flooded @ load < 20% @ 20% ≤ load < 50% @ load ≥ 50%	46.0Vdc 44.8Vdc 42.4Vdc	
Low DC Cut-off Voltage Just for AGM and Flooded @ load < 20% @ 20% ≤ load < 50% @ load ≥ 50%	When OP2 is allowed OP2 OP1 42.0Vdc 45.2Vdc 40.8Vdc 44.0Vdc 38.4Vdc 41.6Vdc	When OP2 is forbidden OP1 45.2Vdc 44.0Vdc 41.6Vdc

Table 3 Charge Mode Specifications

Utility Charging Mode		
INVERTER MODEL	8.5KVA	11.0KVA
Charging Current (Max) (AC+PV)	140Amp	160Amp
AC Charging Current (Max)	120Amp (@ $V_{I/P}=230V_{ac}$)	
Bulk Charging Voltage	Flooded Battery	58.4Vdc
	AGM / Gel Battery	56.4Vdc
Floating Charging Voltage	54Vdc	
Overcharge Protection	63Vdc	
Charging Algorithm	3-Step	
Charging Curve	<p>The graph plots Battery Voltage (per cell) on the left y-axis and Charging Current (%) on the right y-axis against Time on the x-axis. The voltage curve (black) starts at 2.25Vdc, rises linearly to 2.43Vdc (labeled as 2.35Vdc), remains constant during the Absorption phase, and then slightly drops to a Maintenance level. The current curve (red) starts at 100% and decreases as voltage rises, then remains constant during Absorption, and finally drops to a low level during Maintenance. The Bulk phase is labeled 'Bulk (Constant Current)', Absorption is 'Absorption (Constant Voltage)', and Maintenance is 'Maintenance (Floating)'. Time intervals T0 and T1 are indicated, with T1 = 10 * T0, minimum 10mins, maximum 8hrs.</p>	
Solar Input		
INVERTER MODEL	8.5KVA	11.0KVA
Rated Power	5000W*2	5500W*2
Max. PV Array Open Circuit Voltage	500Vdc	
PV Array MPPT Voltage Range	60Vdc~500Vdc	
Max. MPPT Charge Current	140A	160A
Max. Input Current	18A*2	18A*2

Table 4 General Specifications

INVERTER MODEL	8.5KVA	11.0KVA
Safety Certification	CE	
Operating Temperature Range	-10°C to 55°C	
Storage temperature	-15°C~ 60°C	
Humidity	5% to 95% Relative Humidity (Non-condensing)	
Dimension(D*W*H), mm	540x403x122	
Net Weight, kg	14.4	14.8

TROUBLE SHOOTING

Problem	LCD/LED/Buzzer	Explanation / Possible cause	What to do
Unit shuts down automatically during startup process.	LCD/LEDs and buzzer will be active for 3 seconds and then complete off.	The battery voltage is too low	Re-charge battery. Replace battery.
No response after power on.	No indication.	1.The battery voltage is far too low. 2.Battery polarity is connected reversed.	Check if batteries and the wiring are connected well. Re-charge battery. Replace battery.
Mains exist but the unit works in battery mode.	Input voltage is displayed as 0 on the LCD and green LED is flashing.	Input protector is tripped	Check if AC breaker is tripped and AC wiring is connected well.
	Green LED is flashing.	Insufficient quality of AC power. (Shore or Generator)	1.Check if AC wires are too thin and/or too long. 2.Check if generator (if applied) is working well or if input voltage range setting is correct. (UPS Appliance)
	Green LED is flashing.	Set "SBU" or "SUB" as the priority of output source.	Change output source priority to Utility first.
When the unit is turned on, internal relay is switched on and off repeatedly.	LCD display and LEDs are flashing	Battery is disconnected.	Check if battery wires are connected well.
Buzzer beeps continuously and red LED is on.	Fault code D0	Overload error. The inverter is overload 100% and time is up.	Reduce the connected load by switching off some equipment.
	Fault code A2	Output short circuited.	Check if wiring is connected well and remove abnormal load.
	Fault code F2	Internal temperature of inverter component is over 100°C.	Check whether the air flow of the unit is blocked or whether the ambient temperature is too high.
	Fault code B0	Battery is over-charged.	Return to repair center.
		The battery voltage is too high.	Check if spec and quantity of batteries are meet requirements.
	Fault code A1/A5	Output abnormal (Inverter voltage below than 190Vac or is higher than 260Vac)	1.Reduce the connected load. 2.Return to repair center
	Fault code F3/F4	Internal components failed.	Return to repair center.
	Fault code A2	Over current or surge.	Restart the unit, if the error happens again, please return to repair center.
	Fault code F5	Bus voltage is too low.	
	Fault code A3	Output voltage is unbalanced.	
Another fault code		If the wires is connected well, please return to repair center.	

Parallel Installation Guide

Instruction

This inverter can be used in parallel with two different operation modes.

1. Parallel operation in single phase with up to 6 units. The supported maximum output power is 8.5KW-8.5KVA/11KW-11KVA *6pcs.

2. Maximum 6 units work together to support three-phase equipment. 4 units support one phase maximum. The supported maximum output power is 8.5KW-8.5KVA*6pcs/11KW-11KVA *6pcs, one phase can be up to 8.5KW-8.5KVA *4pcs/11KW-11KVA *4pcs.

NOTE: If this unit is bundled with parallel cable, this inverter is default supported parallel operation.

Package Contents

In parallel kit, you will find the following items in the package:

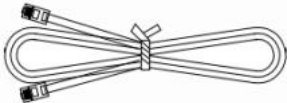

Parallel communication cable

Mounting the Unit

When installing multiple units, please follow below chart.

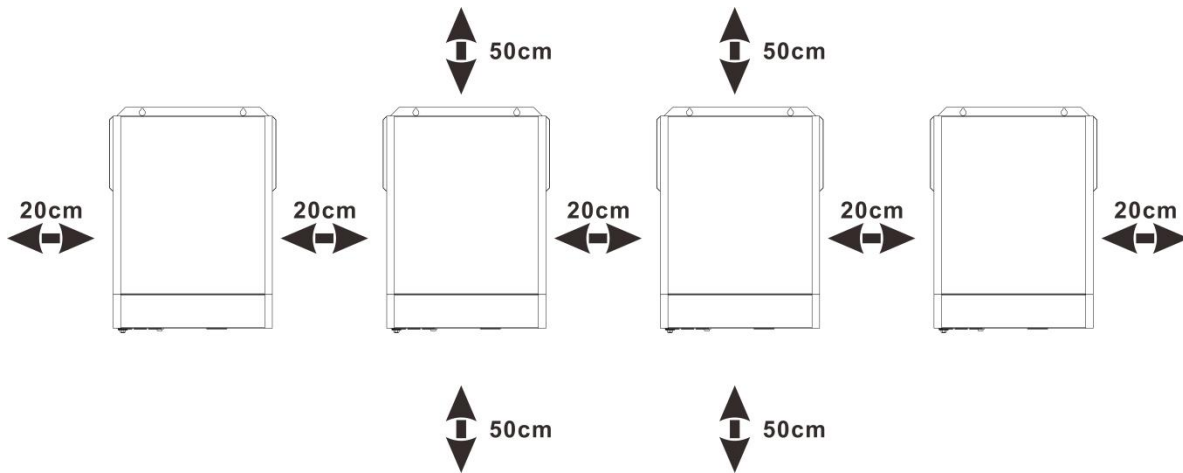

NOTE: For proper air circulation to dissipate heat, allow a clearance of approx. 20 cm to the side and approx. 50 cm above and below the unit. Be sure to install each unit in the same level.

Wiring Connection

NOTICE: It's requested to connect to battery for parallel operation.

The cable size of each inverter is shown as below:

Recommended battery cable and terminal size for each inverter:

Model	Maximum Amperage	Battery capacity	Wire Size	Cable mm ²	Terminal size(mm)			Torque value
					L	W	D	
8.5KVA	180A	400AH	4AWG*2	25	37	22	8.4	10~12 Nm
11.0KVA	220A	600AH	2AWG*2	38	37	22	8.4	10~12 Nm

Stripping Length:

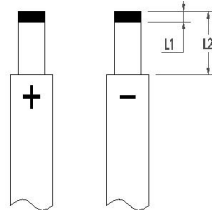

Terminal size:

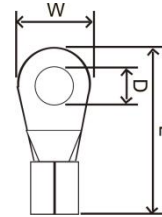

WARNING: Be sure the length of all battery cables is the same. Otherwise, there will be voltage difference between inverter and battery to cause parallel inverters not working.

Recommended AC input and output cable size for each inverter:

Model	Gauge	Torque Value
All Model	6 AWG	1.2~ 1.4Nm

You need to connect the cables of each inverter together. Take the battery cables for example: You need to use a connector or bus-bar as a joint to connect the battery cables together, and then connect to the battery terminal. The cable size used from joint to battery should be X times cable size in the tables above. "X" indicates the number of inverters connected in parallel.

Regarding AC input and output, please also follow the same principle.

CAUTION!! Please install the breaker at the battery and AC input side. This will ensure the inverter can be securely disconnected during maintenance and fully protected from over current of battery or AC input. The recommended mounted location of the breakers is shown in the figures in Point 5.

Recommended breaker specification of battery for each inverter:

Model	1 unit*
8.5KVA	200A/60VDC
11.0KVA	250A/60VDC

*If you want to use only one breaker at the battery side for the whole system, the rating of the breaker should be X times current of 1 unit. "X" indicates the number of inverters connected in parallel.

Recommended breaker specification of AC input with single phase:

Model	2 units	3 units	4 units	5 units	6 units
All Model	100A	150A	200A	250A	300A

Note1: Also, you can use 63A breaker for only 1 unit, and each inverter has a breaker at its AC input.

Recommended battery capacity

Inverter parallel numbers	2	3	4	5	6
Battery Capacity	800AH	1200AH	1600AH	2000AH	2400AH

WARNING! Be sure that all inverters will share the same battery bank. Otherwise, the inverters will transfer to fault mode.

Communicating with battery BMS in parallel system

1. Only support common battery installation
2. Use RJ45 cable to connect any one of inverters (no need to connect to a specific inverter) and Lithium battery.
3. Simply set this inverter battery type to "Li 2" in LCD program 01(F2). Others should be default value "AGM".

Note: Make sure only one inverter is connected RJ45 cable and only the one is set as Lithium in LCD program 01(F2).

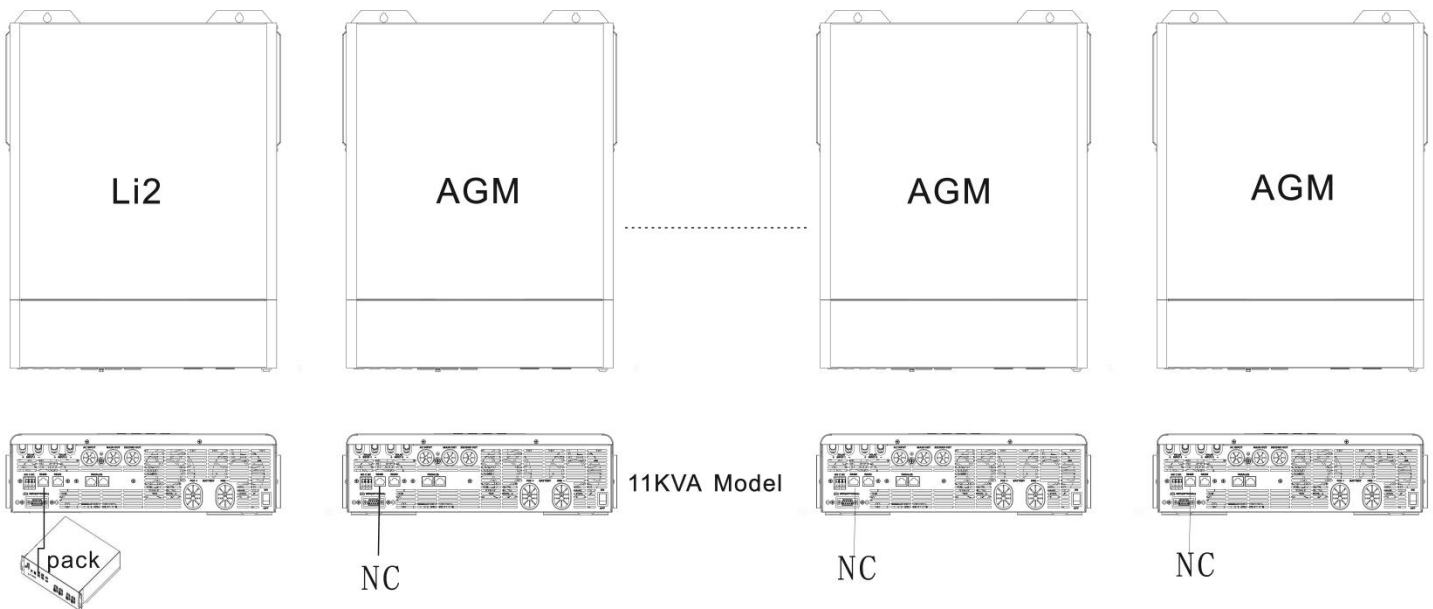

Parallel Operation in Single phase

Two inverters in parallel:

Power Connection

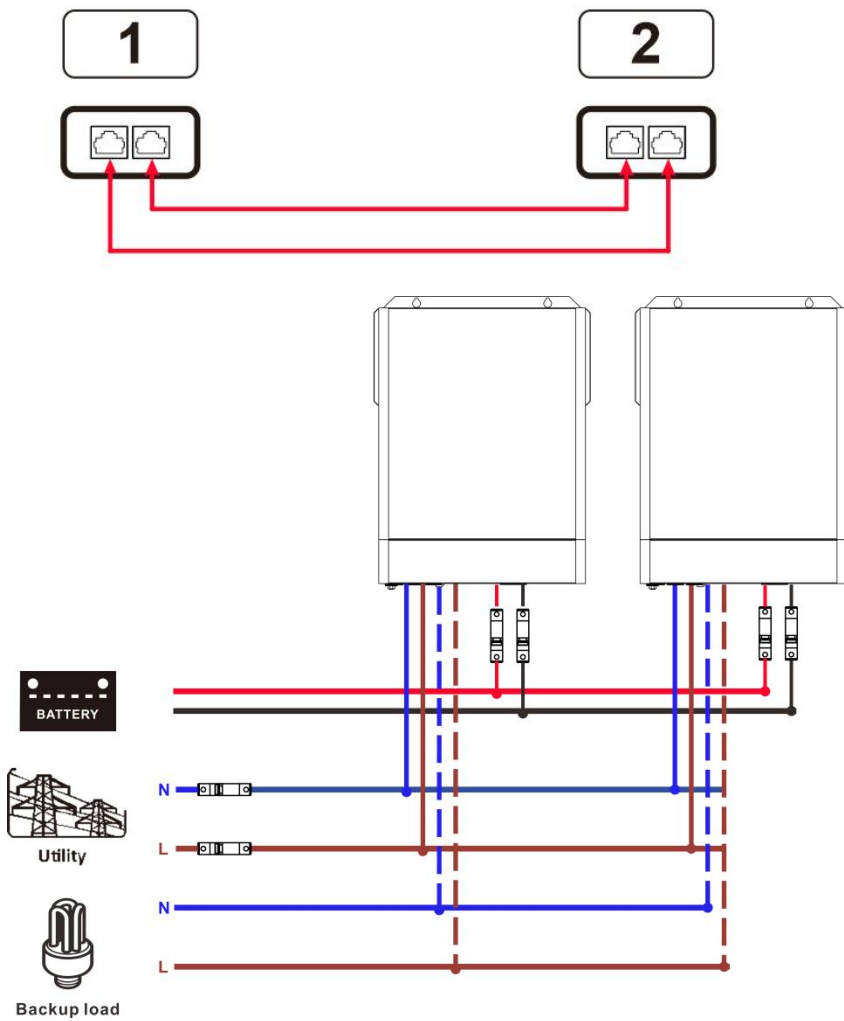

Communication Connection

Three inverters in parallel:

Power Connection

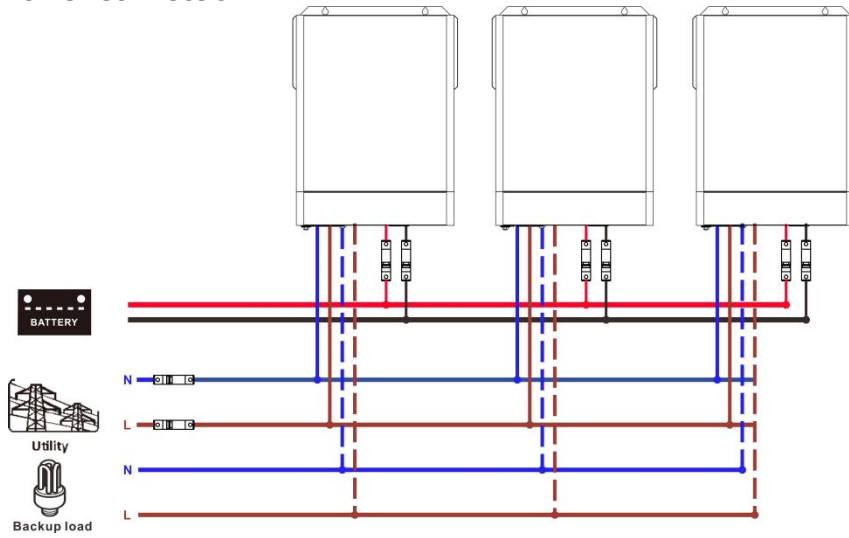

Communication Connection

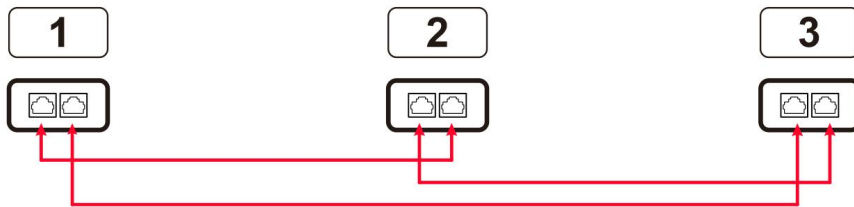

Four inverters in parallel:

Power Connection

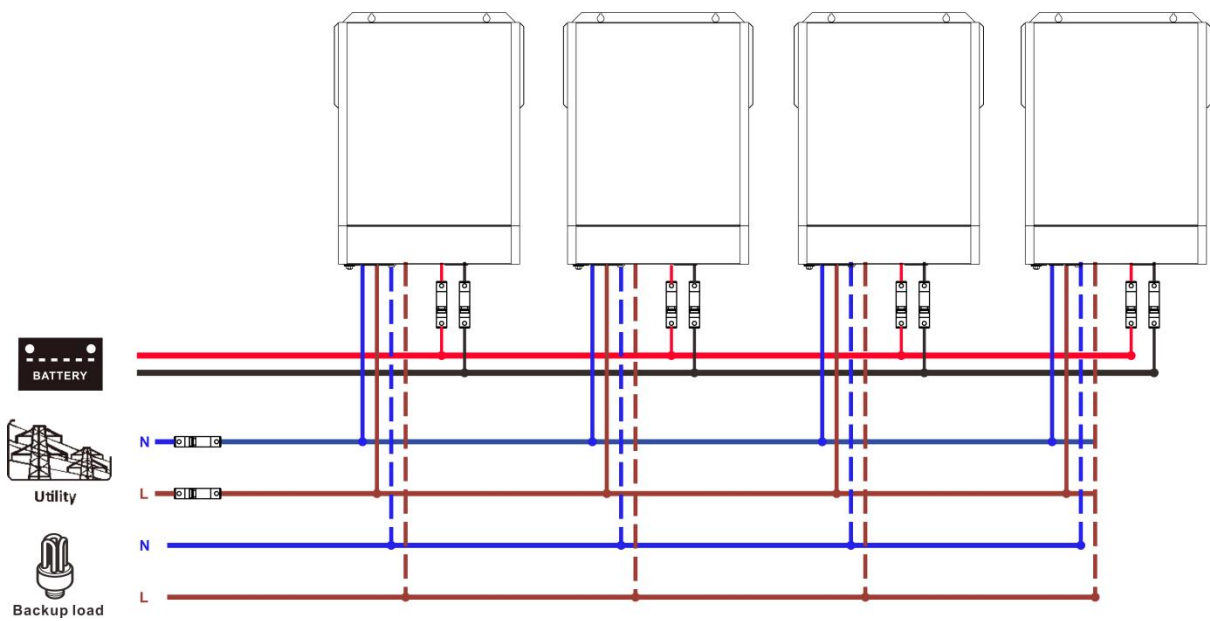

Communication Connection



More than four inverters in parallel:

Power Connection

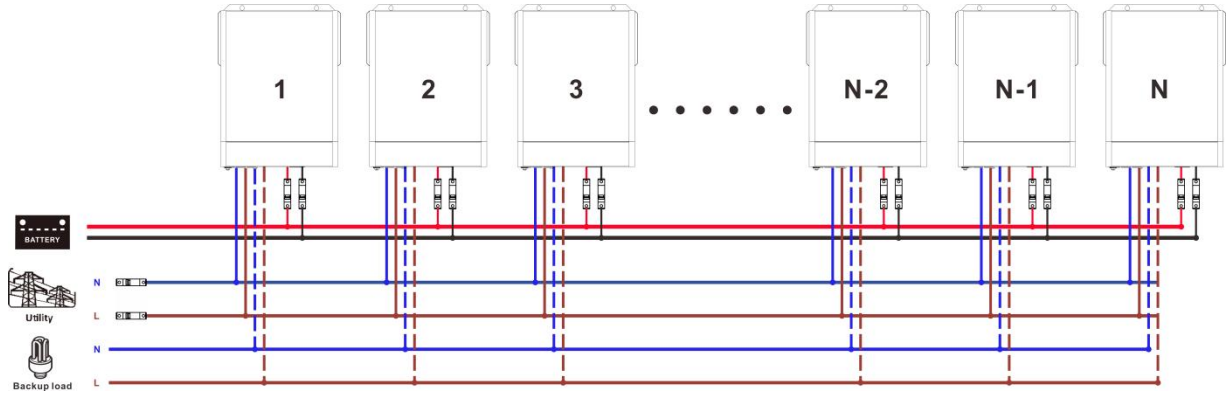

Communication Connection



Note: $N_{max}=6$ units.

Support 3-phase equipment

One inverter in each phase:

Power Connection

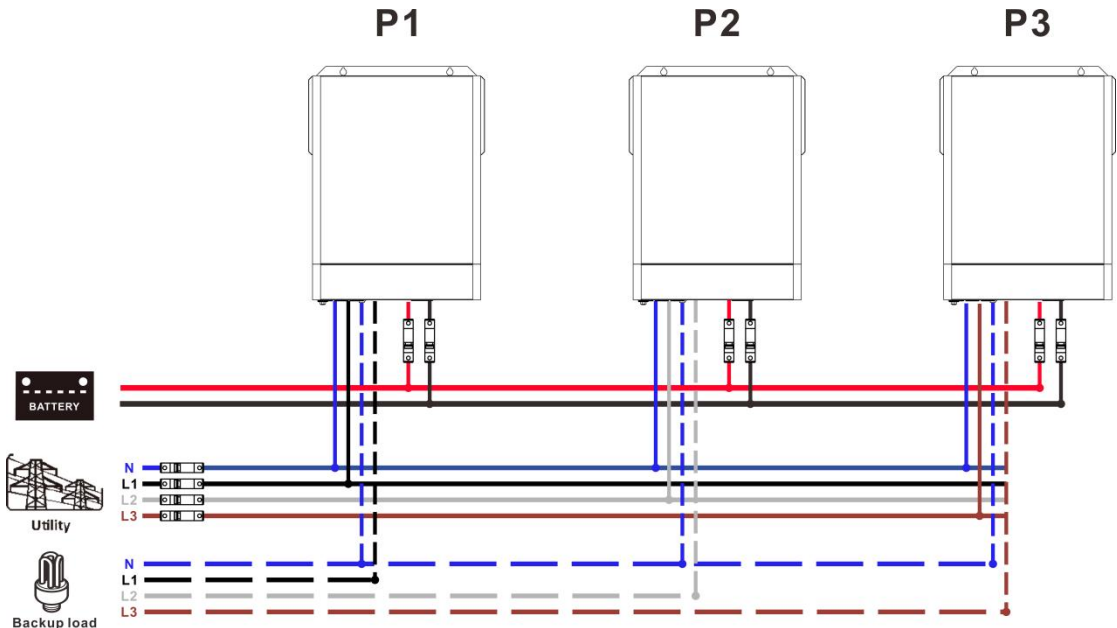

Communication Connection

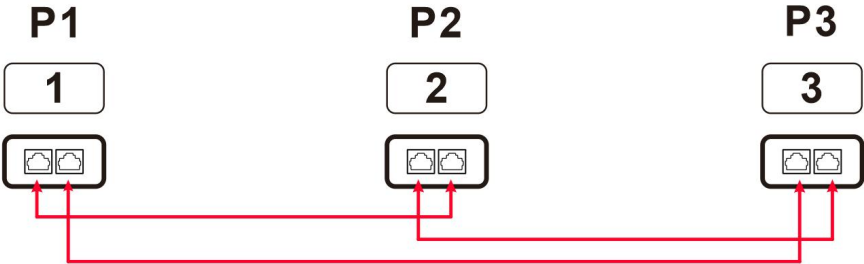

More than three inverters in three phases:

Note: It's up to customer's demand to pick 4 inverters in any phase.

P1: L1-phase, P2: L2-phase, P3: L3-phase.

$N = N1 + N2 + N3$, $N_{max} = 6 \text{ units}$.

Power Connection

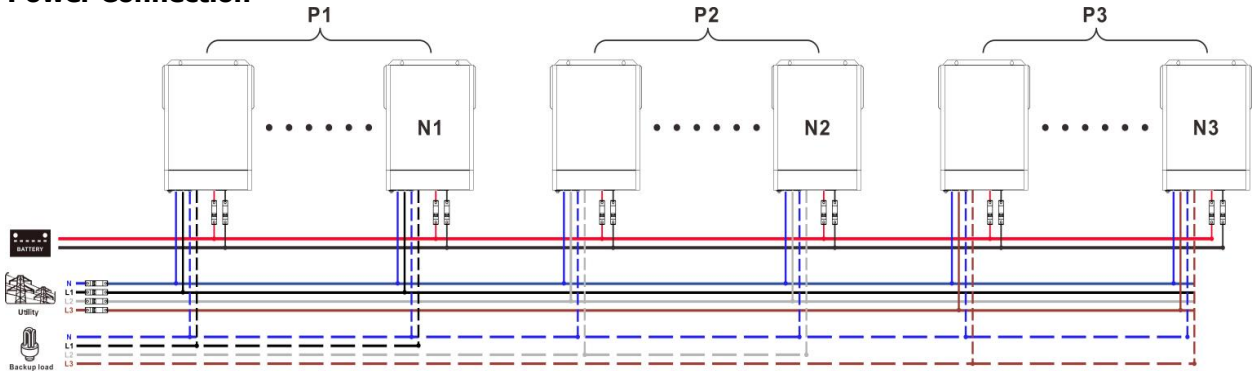

$N1_{max} = 4$ units is in one phase and one inverter for the other two phases ($N2 = N3 = 1$) :

Power Connection

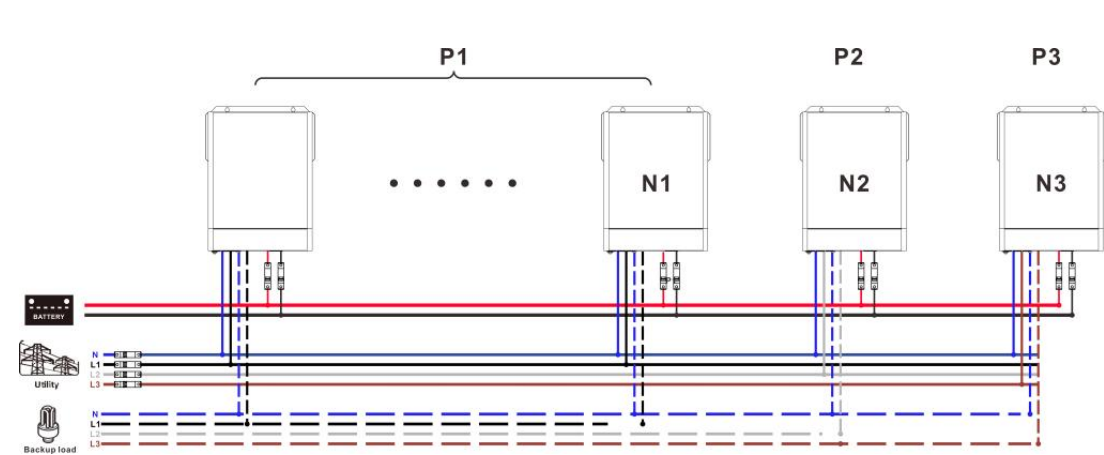

$N1_{max}$ or $N2_{max}$ 4 units is in one phase and one inverter for the P3 phase ($N3 = 1$) :

Power Connection

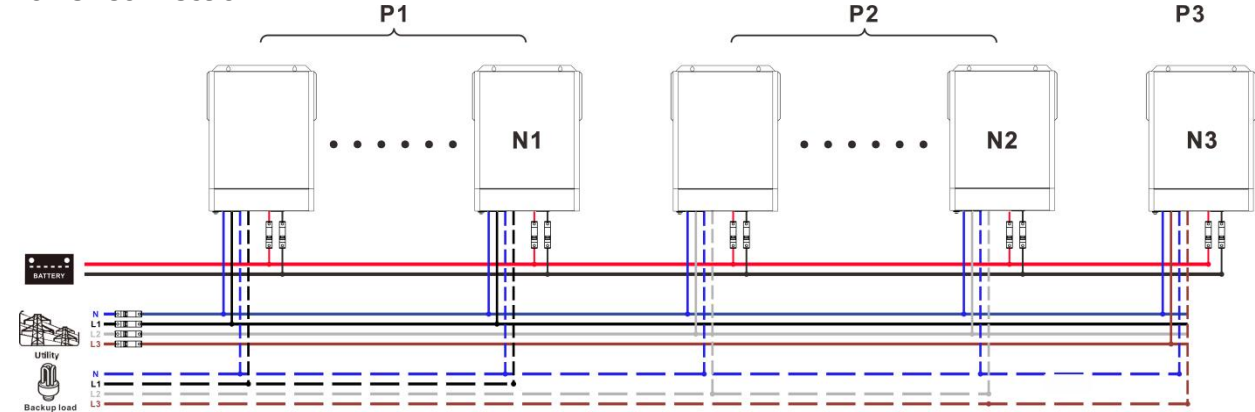

Communication Connection



PV Connection

Please refer to user manual of single unit for PV Connection.

CAUTION: Each inverter should connect to PV modules separately.

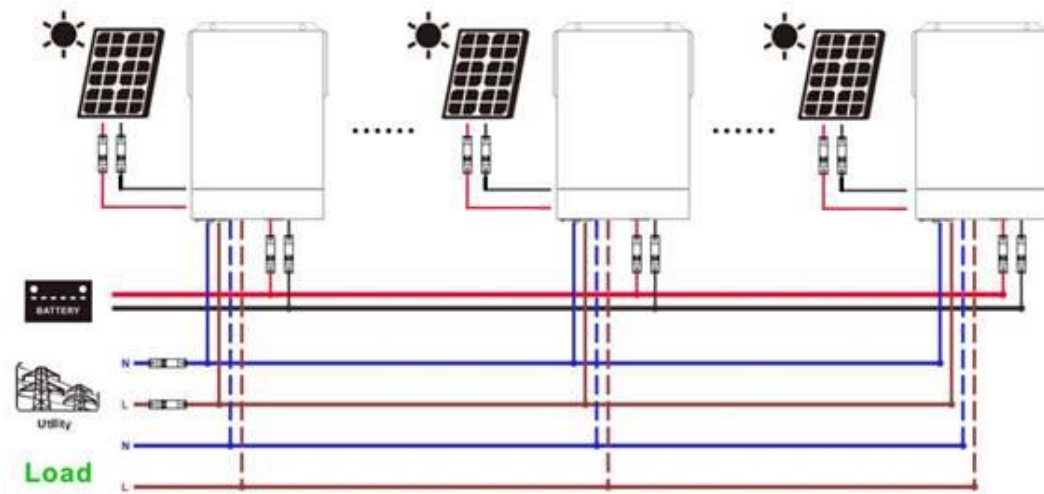

Commissioning

Parallel in single/three phase



Step 1: Check the following requirements before commissioning:

1. Correct wire connection
2. Ensure all breakers in Line wires of load side are open and each Neutral wires of each unit are connected.

Step 2: Turn on each unit and set "PAL" or "3Px" in LCD setting program 02(F1) of each unit. And then shut down all units.

NOET: It's necessary to turn off each unit (Keep power on) when setting LCD program. Otherwise, the setting cannot be programmed.

Step 3: Turn on each unit.

NOTE: Master and slave units are randomly defined. If it is master, the icon  flashes, if it is slave unit, the icon  normally on.

Step 4: Switch on all AC breakers of Line wires in AC input. It's better to have all inverters connect to utility at the same time. If detecting AC connection, they will work normally.

Step 5: If there is no more fault alarm, the parallel system is completely installed.

Step 6: Please switch on all breakers of Line wires in load side. This system will start to provide power to the load.

Trouble shooting

Situation		Solution
Fault Code	Fault Event Description	
E0	Host data loss	<ol style="list-style-type: none"> 1. Check if communication cables are connected well and restart the inverter. 2. If the problem remains, please contact your installer.
E1	Synchronization data loss	<ol style="list-style-type: none"> 1. Check if communication cables are connected well and restart the inverter. 2. If the problem remains, please contact your installer.
E2	Incompatible battery type	<ol style="list-style-type: none"> 1. Check the battery type setting to ensure that only the device connected to the BMS in the system is one of Li1 or Li2 or Li3 2. If the problem remains, please contact your installer.
E3	Firmware version inconsistent	<ol style="list-style-type: none"> 1. Update all inverter firmware to the same version. 2. Check the version of each inverter via LCD setting and make sure the CPU versions are same. If not, please contact your installer to provide the firmware to update. 3. After updating, if the problem remains, please contact your installer.

Situation		Solution
Warning Code	Warning Event Description	
0E	CAN communication loss	<ol style="list-style-type: none"> 1. Check if communication cables are connected well and restart the inverter. 2. If the problem remains, please contact your installer.
1E	AC output mode setting is different.	<ol style="list-style-type: none"> 1. Switch off the inverter and check LCD setting program 02(F1). 2. For parallel system in single phase, make sure "PAL" is set on program 02(F1). 3. If the problem remains, please contact your installer.
2E	The battery voltage of each inverter is not the same.	<ol style="list-style-type: none"> 1. Make sure all inverters share same groups of batteries together. 2. Remove all loads and disconnect AC input and PV input. Then, check battery voltage of all inverters. If the values from all inverters are close, please check if all battery cables are the same length and same material type. Otherwise, please contact your installer to provide SOP to calibrate battery voltage of each inverter. 3. If the problem remains, please contact your installer.

