



#### QUICK SELECTION / Selezione veloce

input speed ( $n_1$ ) = 1400 min<sup>-1</sup>

Output Speed $n_2$ [min <sup>-1</sup> ]	Ratio $i$	Motor power $P_{1M}$ [kW]	Output torque $M_{2M}$ [Nm]	Service factor $f.s.$	Nominal power $P_{1R}$ [kW]	Nominal torque $M_{2R}$ [Nm]	B5 motor flanges not available				Available B14 motor flanges				Output Shaft		
							-	-	-	-	Q	R	T	-			Ratio code
398	<b>3.52</b>	1.5	34	2.3	<b>3.5</b>	<b>80</b>	-	-	-	-	C	C	-	-	2821	standard ø24	-
320	<b>4.37</b>	1.5	43	2.1	<b>3.1</b>	<b>90</b>	-	-	-	-	C	C	-	-	2818		
252	<b>5.55</b>	1.5	54	1.8	<b>2.8</b>	<b>100</b>	-	-	-	-	C	C	-	-	2813		
220	<b>6.36</b>	1.5	62	1.5	<b>2.3</b>	<b>95</b>	-	-	-	-	C	C	-	-	1921		
191	<b>7.33</b>	1.5	72	1.7	<b>2.5</b>	<b>120</b>	-	-	-	-	C	C	-	-	2812		
177	<b>7.89</b>	1.5	77	1.6	<b>2.3</b>	<b>120</b>	-	-	-	-	C	C	-	-	1918		
139	<b>10.06</b>	1.5	99	1.5	<b>2.3</b>	<b>150</b>	-	-	-	-	C	C	-	-	1913		
120	<b>11.66</b>	1.5	114	1.5	<b>2.3</b>	<b>174</b>	-	-	-	-	C	C	-	-	1713		
106	<b>13.26</b>	1.5	130	1.2	<b>1.8</b>	<b>160</b>	-	-	-	-	C	C	-	-	1912		
102	<b>13.68</b>	1.5	134	1.1	<b>1.6</b>	<b>144</b>	-	-	-	-	C	C	-	-	1513		
91	<b>15.37</b>	1.5	151	1.1	<b>1.6</b>	<b>160</b>	-	-	-	-	C	C	-	-	1712		
86	<b>16.20</b>	1.5	159	0.9	<b>1.3</b>	<b>138</b>	-	-	-	-	C	C	-	-	1910		
78	<b>18.04</b>	1.5	177	0.9	<b>1.4</b>	<b>160</b>	-	-	-	-	C	C	-	-	1512		
74	<b>18.80</b>	1.1	135	1.0	<b>1.1</b>	<b>138</b>	-	-	-	-	C	C	-	-	1710		
65	<b>21.54</b>	1.1	155	1.0	<b>1.1</b>	<b>160</b>	-	-	-	-	C	C	-	-	1312		
63	<b>22.29</b>	1.1	161	1.0	<b>1.1</b>	<b>167</b>	-	-	-	-	C	C	-	-	1013		
53	<b>26.30</b>	0.75	129	1.1	<b>0.80</b>	<b>138</b>	-	-	-	-	C	C	-	-	1310		
47.6	<b>29.40</b>	0.75	144	1.1	<b>0.83</b>	<b>160</b>	-	-	-	-	C	C	-	-	1012		
39	<b>35.91</b>	0.55	129	1.1	<b>0.59</b>	<b>138</b>	-	-	-	-	C	C	-	-	1010		
36.5	<b>38.37</b>	0.55	138	1.2	<b>0.64</b>	<b>160</b>	-	-	-	-	C	C	-	-	912		
29.9	<b>46.86</b>	0.55	169	0.8	<b>0.45</b>	<b>138</b>	-	-	-	-	C	C	-	-	910		
27.6	<b>50.67</b>	0.37	123	1.1	<b>0.40</b>	<b>132</b>	-	-	-	-	C	C	-	-	712		
22.6	<b>61.88</b>	0.37	150	0.9	<b>0.34</b>	<b>138</b>	-	-	-	-	C	C	-	-	710		

The dynamic efficiency is **0.96** for all ratios

Motor Flanges Available  
Flange Motore Disponibili

B) Supplied with Reduction Bushing  
Fornito con Bussola di Riduzione

B) Available on Request without reduction bushing  
Disponibile a Richiesta senza Bussola di Riduzione

C) Motor Flange Holes Position  
Posizione Fori Flangia Motore

Life lubrication - Fully synthetic oil  
Mounting position to be specified - B6-B7-B8-V1-V3-V8

- EN** Unit 4021 is supplied with synthetic oil for lifetime lubrication, no maintenance is necessary. For complete documentation please visit our web site.
- I** Il riduttore 4021 viene fornito completo di olio sintetico per la lubrificazione permanente e non necessita di alcuna manutenzione. Per la documentazione completa consulta il nostro sito.
- D** Das Getriebe 4021 ist mit synthetischem Öl gefüllt und ist lebensdauergeschmiert. Die komplette Dokumentation, Wartungs- und Inbetriebnahmeanleitungen finden Sie unter.
- E** El reductor tamaño 4021 se suministra, lubricado de por vida con aceite sintético y no requieren mantenimiento alguna. Para documentación completa, consultar nuestra Web.

### RADIAL AND AXIAL LOADS

Output shaft  
Albero di uscita

$F_{eq} = F_R \cdot \frac{46}{X+21}$

$n_2$	FA	FR	$n_2$	FA	FR	$n_2$	FA	FR
300	310	1550	140	406	2030	70	540	2700
250	330	1650	120	448	2240	40	600	3000
200	360	1800	85	480	2400	15	600	3000

P4021-F... Output flange  
flangia di uscita

Gearbox weight  
peso riduttore **11.4 kg**

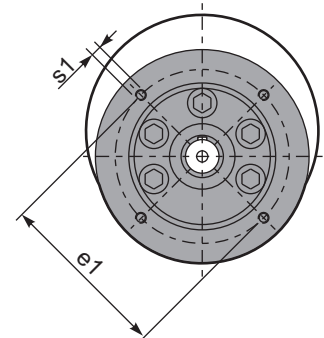
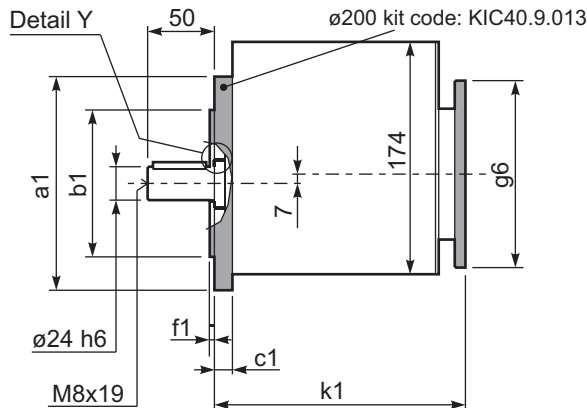
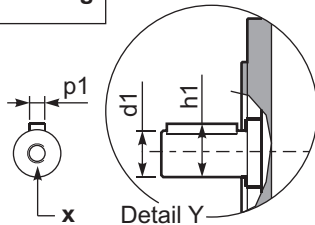

#### Output shafts / albero di uscita

	Shaft - d1	p1	h1	x
Standard	ø 24x50	8	27	M8x19
*On request A richiesta	-	-	-	-

#### Output flanges / flange di uscita

	a1	ø	b1	c1	e1	f1	s1
Standard	200	130	13.5	165	3.5	M10x13	
*On request A richiesta	-	-	-	-	-	-	-

#### Input flanges / flange di entrata

	g6	k1	kit code
	105 (71B14)	186	KI63.4.047
	120 (80B14)	187	KI63.4.046
	140 (90B14)	188	KI63.4.041