

QUICK SELECTION / Selezione veloce The dynamic efficiency is **0.94** for all ratios **input speed (n₁) = 1400 min⁻¹**

Output Speed n ₂ [min ⁻¹]	Ratio i	Motor power P _{1M} [kW]	Output torque M _{2M} [Nm]	Service factor f.s.	Nominal power P _{1R} [kW]	Nominal torque M _{2R} [Nm]	Available B5 motor flanges				Available B14 motor flanges			Output Shaft 	Ratios code 	
							B	C	D	E	Q	R	T			
							63	71	80	90	71	80	90			
24.7	56.76	0.55	201	1.2	0.69	250	B				C	C		191311	standard ø30 ø35 On request	-
21.3	65.79	0.55	233	1.1	0.59	250	B				C	C		171311		
18.1	77.23	0.55	274	0.9	0.50	250	B				C	C		151311		
16.0	87.23	0.37	207	1.2	0.45	250	B				C	C		19138		
15.2	92.18	0.37	219	1.1	0.42	250	B				C	C		131311		
13.9	100.47	0.37	238	1.0	0.39	250	B				C	C		19811		
12.0	116.45	0.37	276	0.9	0.33	250	B				C	C		17811		
11.1	125.82	0.25	201	1.2	0.31	250	B				C	C		101311		
9.9	141.66	0.25	227	1.1	0.28	250	B				C	C		13138		
8.6	163.16	0.25	261	1.0	0.24	250	B				C	C		13811		
7.8	178.96	0.18	219	1.1	0.22	250	B				C	C		1788		
7.2	193.36	0.18	237	1.1	0.20	250	B				C	C		10138		
6.5	216.84	0.18	265	0.9	0.18	250	B				C	C		71311		
5.5	252.36	0.12	200	1.3	0.15	250	B				C	C		9138		
4.8	290.67	0.12	230	1.1	0.13	250	B				C	C		9811		
4.2	333.23	0.09	210	1.2	0.12	250	B				C	C		7138		
3.6	383.82	0.09	242	1.0	0.10	250	B				C	C		7811		
3.1	446.70	0.09	282	0.9	0.09	250	B				C	C		988		
2.4	589.85	0.06	244	1.0	0.07	250	B				C	C		788		

Motor Flanges Available
Flange Motore Disponibili

B) Supplied with Reduction Bushing
Fornito con Bussola di Riduzione

B) Available on Request without reduction bushing
Disponibile a Richiesta senza Bussola di Riduzione

C) Motor Flange Holes Position
Posizione Fori Flangia Motore

EN Unit **X53A** is supplied with synthetic oil for lifetime lubrication, no maintenance is necessary. See table 1 for lubrication and recommended quantity. In table 2 please see possible radial loads and axial loads on the gearbox. For complete documentation please visit our web site.

I Il riduttore **X53A** viene fornito completo di olio sintetico per la lubrificazione permanente e non necessita di alcuna manutenzione. Vedi tab.1 per oli e quantità consigliati. In tab.2 sono presenti i carichi radiali e assiali applicabili al riduttore. Per la documentazione completa consulta il nostro sito.

D Das Getriebe **X53A** ist mit synthetischem Öl gefüllt und ist lebensdauergeschmiert. In Tabelle 1 ist die Schmiermenge und das empfohlene Schmiermittel angegeben. In Tabelle 2 sind die zulässigen Radial- und Axialbelastungen des Getriebes aufgeführt. Die komplette Dokumentation, Wartungs- und Inbetriebnahmeanleitungen finden Sie unter.

E El reductor tamaño **X53A** se suministra, lubricado de por vida con aceite sintético y no requieren mantenimiento alguna. Ver tabla 1, para cantidades y aceites recomendados. En la tabla 2, se encuentran las cargas radiales y axiales admitidas por el reductor. Para documentación completa, consultar nuestra Web.

Standard supplied	For these mounting position specify in the order or add oil Per queste posizioni specificare in fase d'ordine o aggiungere olio							
B3	B6	B7	B8	V5	V6	V8	V8	V8
1.30 LT	1.55 LT	0.85 LT	1.45 LT	2.10 LT	1.25 LT	0.95 LT		
AGIP Telium VSF 320	BP Energol SGXP220	SHELL Tivela Oil WB	KLUBER Syntheso D220 EP	MOBIL Glygoyle 30				

Oil plugs on request / Tappi olio a richiesta. **tab. 1**

RADIAL AND AXIAL LOADS

Output shaft
Albero di uscita

$F_{eq} = F_R \cdot \frac{61.5}{X+31}$

Input shaft
albero in entrata

n ₂ [min ⁻¹]	FA	FR	n ₂ [min ⁻¹]	FA	FR	n ₂ [min ⁻¹]	FA	FR
250	600	3000	75	820	4100	15	1660	8300
150	700	3500	50	960	4800			
100	800	4000	25	1350	6750			

n ₁ [min ⁻¹]	FA [N]	FR [N]
1400	400	2000
900	440	2200
600	440	2200

F_R On request taper roller bearings to increase radial loads.
A richiesta cuscinetti a rulli conici per aumentare i carichi radiali.

Input shaft
albero in entrata

*Strong axial loads in the DX direction are not allowed.
Non sono consentiti forti carichi assiali con direzione DX

tab. 2

SELECT THIS TYPE AND THIS SPECIFIC SIZE ON THE WEB PAGES TO GET COMPLETE TECHNICAL DATA.
Selezionare tipo e gandezza specifica nel sito web per la documentazione completa.

PX53A-C... Basic Gearbox
Riduttore base

Gearbox weight
peso riduttore **12.65 kg**

M. flanges	Kit code	øF	A
63B5	K063.4.041	140	246
71B5	K063.4.042	160	244
80/90B5	K063.4.043	200	246
71B14	K063.4.047	105	244
80B14	K063.4.046	120	245
90B14	K063.4.041	140	246

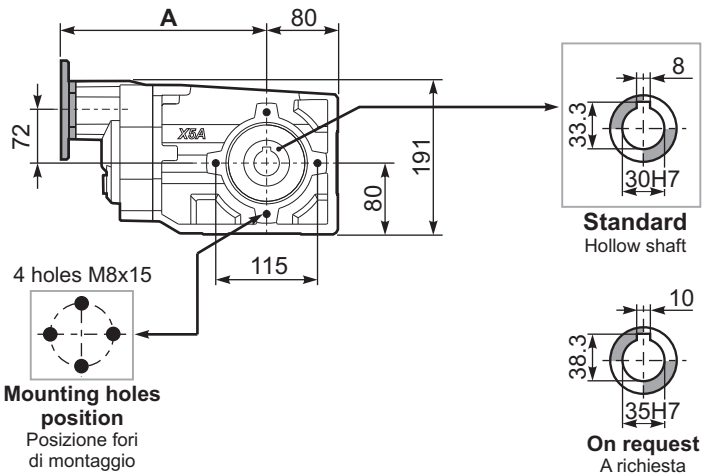
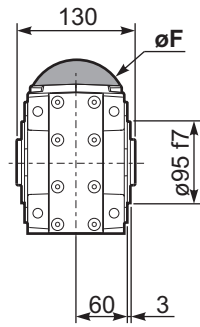

PX53A-N.. Feet
Piedini

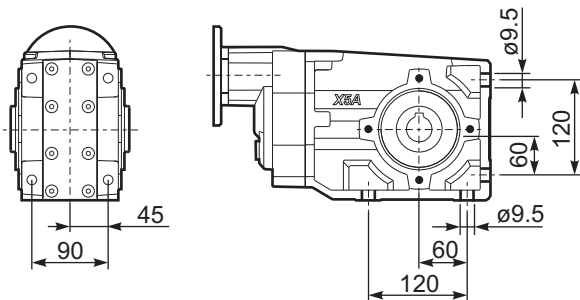

PX53A-F2.. Output flange
Flangia uscita

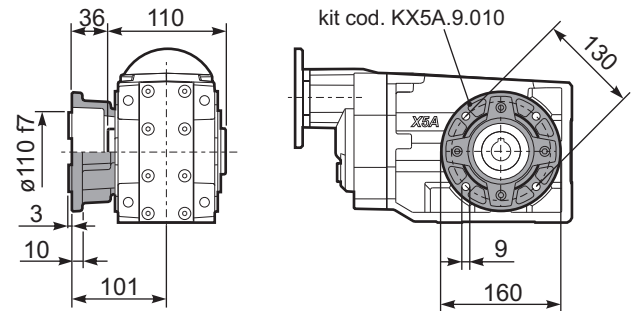

PX53A-F3.. Output flange
Flangia uscita

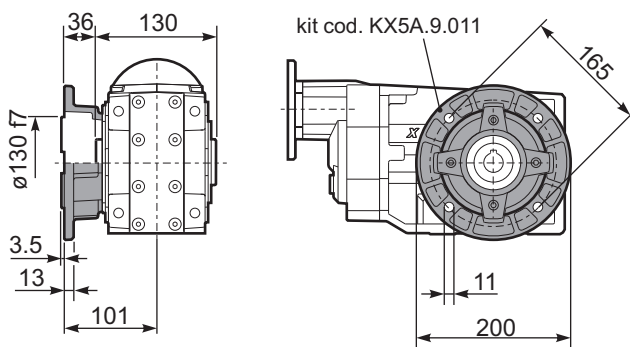

PX53A-F4.. Output flange
Flangia uscita

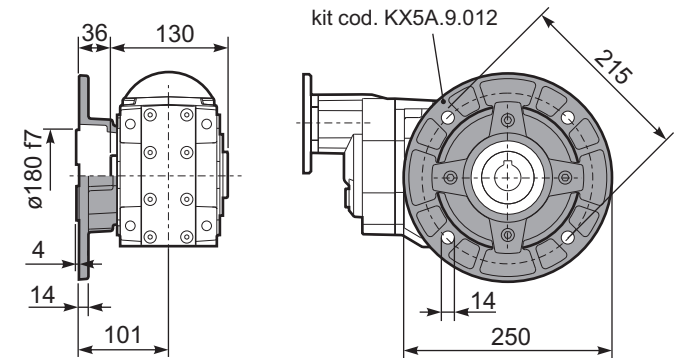

RX53A... Input shaft
Albero in entrata

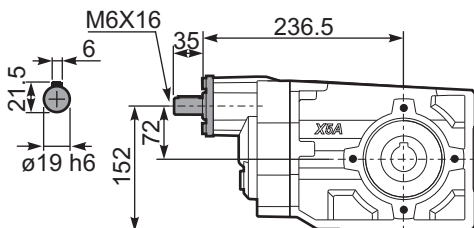

PX53A-BR.. Reaction Arm
Braccio di reazione

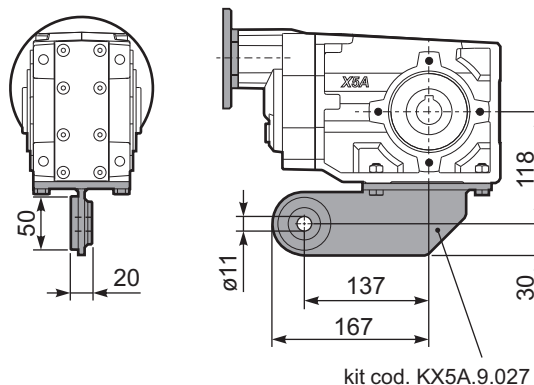

PX53A..A.. Single output shaft
Albero semplice in uscita

