

Installation Drawing on the Right-open Door

Installation Process

(The above drawing with figures is for installation, please cut down this drawing along the line.)

1. Take off the above drawing

According to the size on the above drawing, take off and paste it on the door with the adhesive plaster, mark 4 holes on the door and 2 holes on the connecting holder of doorframe. And then drill holes of $\phi 5.0\text{mm}$.

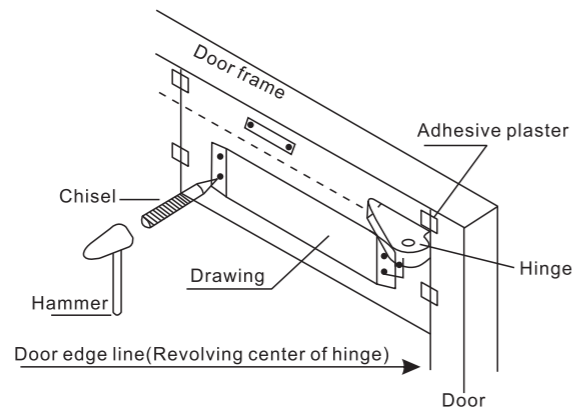

2. Install the main body

According to the position of holes on the door, to install the main body and fixed by 4 screws.

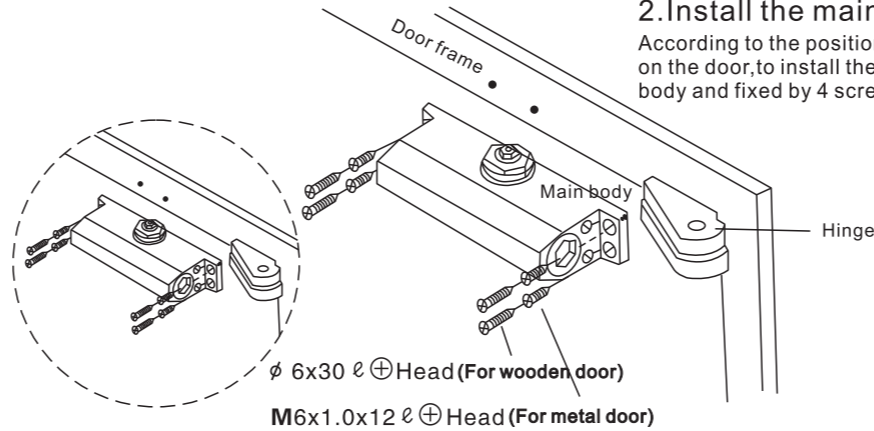

3. Fix the connecting base

According to the position of holes on the doorframe, to install the connecting holder and fixed by 2 screws

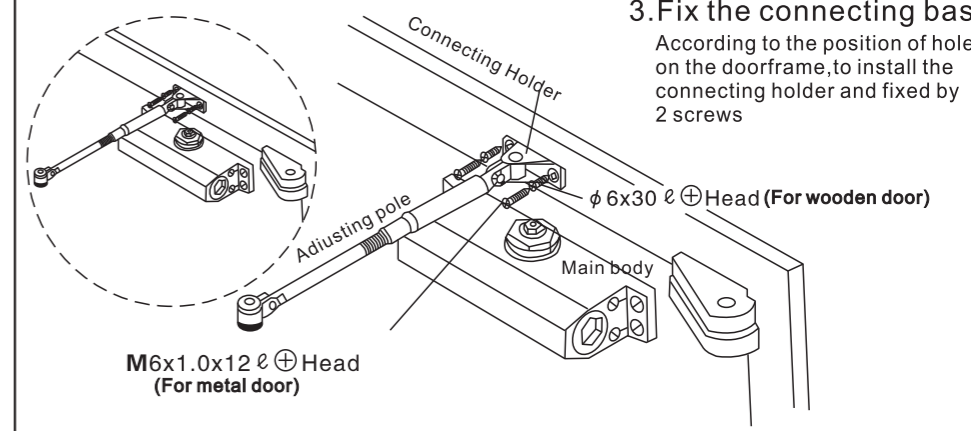

4. Install the supporting plate

Install the supporting plate on the door and fixed by screws.

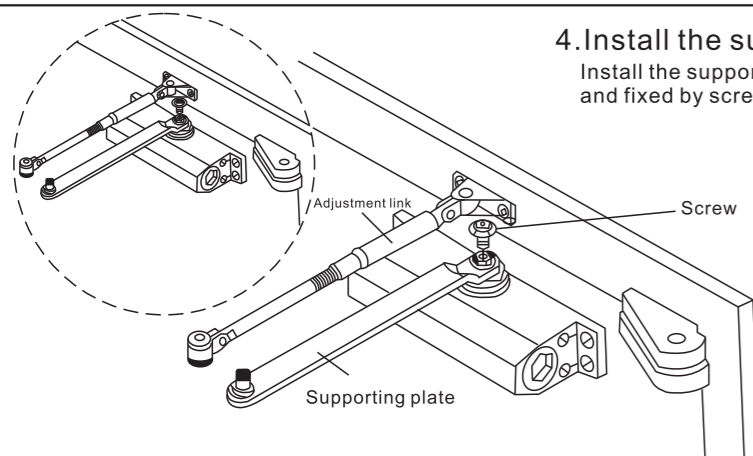

5. Combine the supporting plate and adjustment link

Regulate the adjustment link to make it perpendicular to the door, and fix the adjustment link and supporting plate by screws

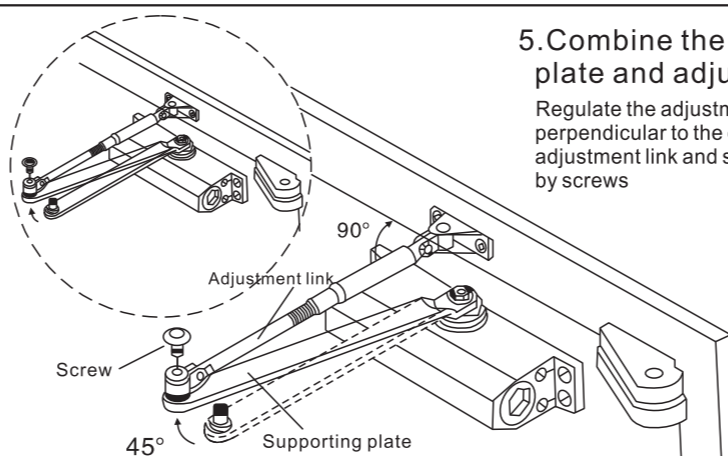

6. Complete the installation

Put on the gear cap finish this installation.

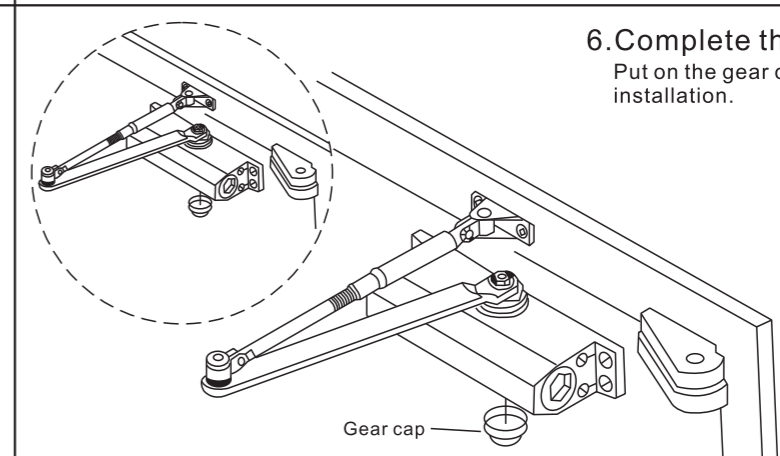

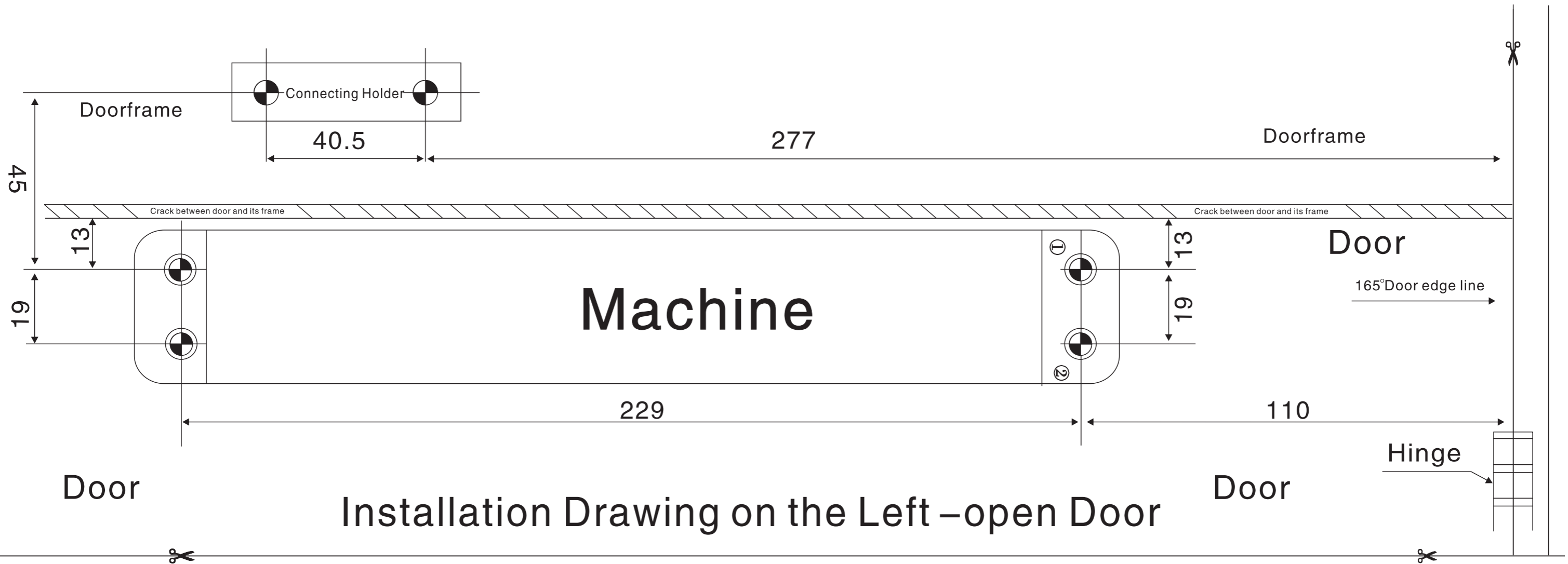

Installation Drawing on the Left - open Door

Specification and Function

- Applicable Door Width(mm) 1000-1600mm
- Applicable door weight(kg) 90-120kg
- Adjustable Section of Closing Speed 150°-20°
- Adjustable Section of Latching Speed 20°-0°
- Spray painted arm to prevent corrosion.
- Precision oil seal to prevent oil leakage.
- High quality die-cast aluminum alloy body, three layers of bright bright paint protection to prevent oxidation.
- Two hydraulic valves independently control the speed of the closing closing process and the locking process as full hydraulic control.
- High carbon steel pinion shaft, rack, high frequency tempering treatment, small deformation, flexible operation.

Installation Notice of Door Closer with Stop function

1. Not to adjust the gear shaft over 180 degree, otherwise, door closer will be damaged.
2. If regulate the gear by swinging arm to 180 degree, the gear will keep stopping. And then the gear should return to original position immediately in order not to damage door closer in the next time.
3. The door closer has the automatically closing function. Better not to pull door by hand.

How to decide the opening direction

The door closer is suitable for left-open door and right-open door installation. Please follow the below instruction to decide the open direction before installation.

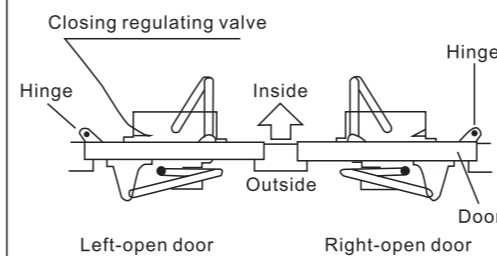

Adjustment of Closing Speed

The 1st adjustment screw controls the 1st segment closing speed
The 2nd adjustment screw controls the 2nd segment closing speed
The adjustment way is clockwise for low, and counterclockwise for fast.

