

SINGLE CHANNEL

Elettropompe sommergibili monocanali 2 poli
Submersible electric pumps single channel 2 poles
Electropompe submersible monocanal 2 pôles
Tauchmotorpumpe mit Einkanalrad, 2-polig
Bombas sumergibles monocanal 2 polos
Одноканальные погружные электронасосы 2 полюса

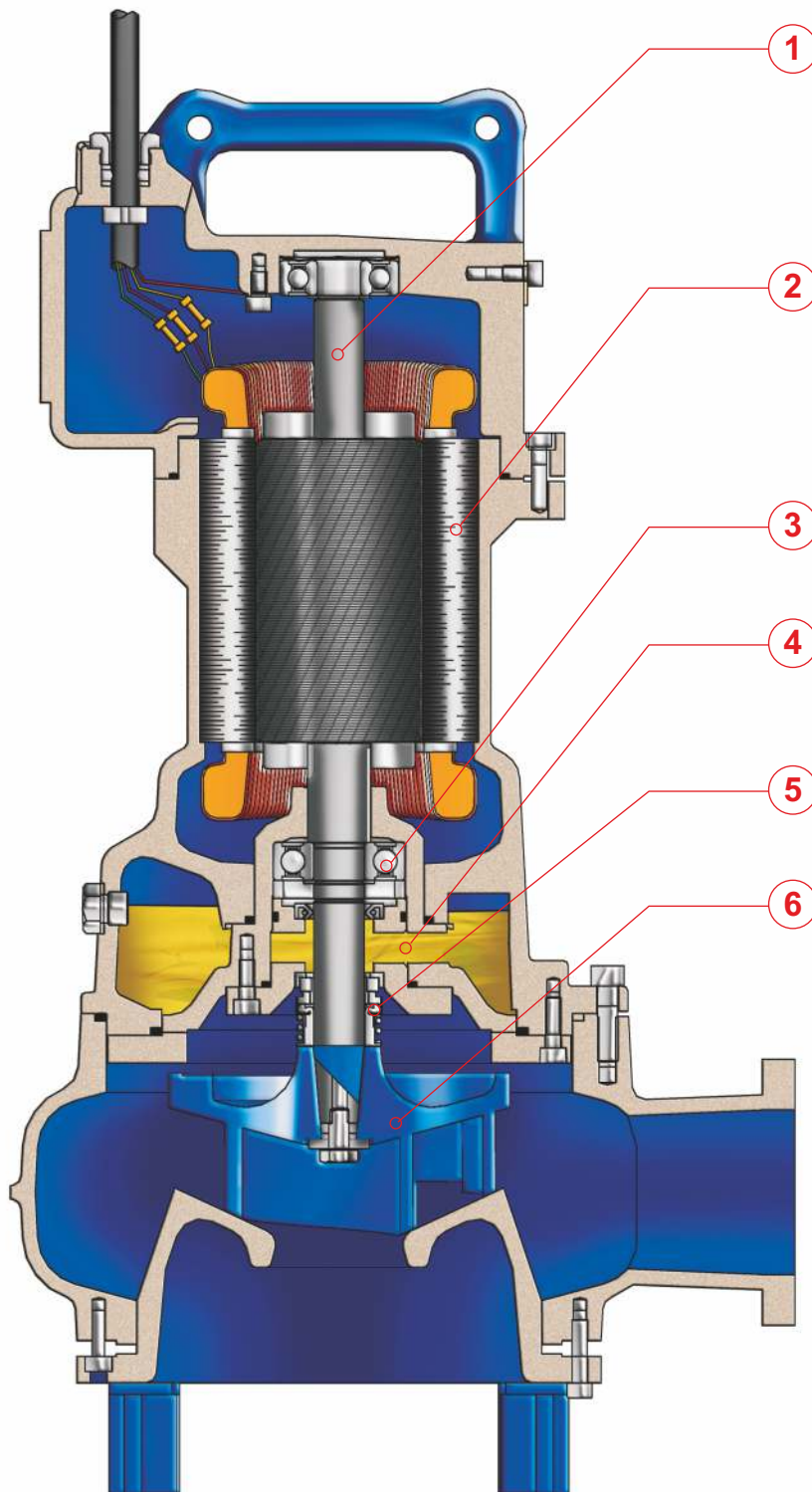

SINGLE CHANNEL

**IMPIEGHI**

Le elettropompe sommergibili monocali sono utilizzate prevalentemente per il pompaggio di acque cariche e luride grigliate. In particolare per lo svuotamento di pozzi neri, pozzi di raccolta liquami da fosse biologiche e pozzi di raccolta acque usate in generale.

PARTICOLARITÀ COSTRUTTIVE

Elettropompe sommergibili di robusta e compatta costruzione, motori elettrici alloggiati in vano a tenuta stagna, collegati mediante alberi di lunghezze ridotte alle giranti situate in voluta tramite interposizione di camera olio tra parte idraulica e motore elettrico.

MATERIALI

Fusioni principali	Ghisa EN-GJL-250
Girante	Ghisa EN-GJL-250+Ni
Cavo elettrico	Neoprene H07RN/F
Albero	Acciaio inossidabile AISI 431 / Duplex
O-rings e paraolio	Nitrile
Bullonerie	Classe A4 - AISI316
Tenuta meccanica	Carburo di silicio / Carburo di silicio

**APPLICATIONS**

Les pompes submersibles monocal sont utilisées principalement pour le pompage d'eaux chargées et usées grillagées. En particulier pour la vidange de puisard noir, puisard de recueillement des eaux usées de fosses biologiques et eaux usées en général.

PARTICULARITÉ DE CONSTRUCTION

Pompes submersibles robustes et compactes, moteurs électriques logés en enceinte étanche, reliés par des arbres de longueurs réduites aux roues, avec interposition d'une chambre à huile entre la partie hydraulique et le moteur électrique.

MATÉRIAUX

Moulures principales	Fonte EN-GJL-250
Roue	Fonte EN-GJL-250+Ni
Câble électrique	Néoprène H07RN/F
Arbre	Acier inoxydable AISI 431 / Duplex
O-ring et joints	Nitrile
vis	Classe A4 - AISI316
Garniture mécanique	Carb. de silicium / carbure de silicium

**UTILIZACION**

Las bombas sumergibles monocanales se utilizan especialmente para bombear aguas cargadas ya filtradas. En particular para vaciar pozos negros, pozos de recogida de líquidos procedentes de fosas biológicas y pozos de recogida de aguas utilizada en general.

DIFERENCIAS PRINCIPALES

Son bombas sumergibles de robusta y compacta construcción, motores eléctricos situados en compartimento separado, conectadas mediante ejes cortos con los impulsores interpuestos con una cámara de aceite entre la parte hidráulica i el motor eléctrico.

MATERIALES

Aleaciones principales	Hierro Fundido EN-GJL-250
Impulsor (turbina)	Hierro Fundido EN-GJL-250+Ni
Cable eléctrico	Neopreno H07RN/F
Eje	Acero inoxidable AISI 431 / Duplex
Anillo de sellados y O-Rings	Nitrilo
Tornillos	Clase A4 - AISI316
Sello mecánico	Carburo de silicio / Carburo de silicio

**APPLICATION**

Submersible electric pumps single channel are used prevalently for the lifting of non corrosive dirty waters also with solid bodies in suspension. In particular for screened waste water and drainage of places subject to flooding, crude and activated sludge.

CONSTRUCTION DATA

Submersible electric pumps, robust in construction, watertight electric motors accommodated in compartment, connected, by shafts of reduced lengths, to the impellers situated at the pump casing by the interposition of oil chamber between the hydraulic side and the electric motor.

MATERIALS

Motor housing	Cast iron EN-GJL-250
Impeller	Cast-iron EN-GJL-250+Ni
Electric cable	Neoprene H07RN/F
Shaft	Stainless Steel AISI 431 / Duplex
O-rings and lip seal	Nitrile
Bolts	A4 - AISI316 class
Mechanical seal	Silicon Carbide / Silicon Carbide

**EINSATZBEREICHE**

Tauchmotorpumpen mit Einkanalrad werden vorwiegend zur Förderung von Abwasser mit Schwebstoffen eingesetzt. Speziell geeignet für vorgemischtes Abwasser und dem Einsatz in überflutungsgefährdeten Gebieten, zur Förderung von schlammhaltigen Medien.

AUSFÜHRUNG

Robuste Tauchmotorpumpe mit wasserdichtem Motor, kompakte Bauart, Laufrad im Pumpengehäuse durch Ölkammer zum Motor getrennt.

WERKSTOFFE

Motorgehäuse	Grauguss EN-GJL-250
Laufrad	Grauguss EN-GJL-250+Ni
Anschlusskabel	Neoprene H07RN/F
Welle	Edelstahl AISI 431 / Duplex
Wellendichtring und O-Ringe	Nitril
Schrauben	Edelstahl A4 - AISI316
Gleitringdichtung	Siliziumkarbid / Siliziumkarbid

**ОБЛАСТЬ ПРИМЕНЕНИЯ**

Одноканальные погружные электронасосы используются, в основном, для перекачки средне- и сильнозагрязненных сточных вод после грубой мех. очистки. В частности, для опорожнения канализационных ям и накопительных емкостей для сточных вод.

КОНСТРУКЦИОННЫЕ ОСОБЕННОСТИ

Погружные электронасосы с прочной и компактной конструкцией. Электродвигатели размещены в секции с герметичным уплотнением и соединены через валы небольшой длины с рабочими колесами, расположенными в гидравлической камере. Валы проходят через масляную камеру между гидравликой и электродвигателем.

МАТЕРИАЛЫ

Основные литые компоненты	Чугун EN-GJL-250
Рабочее колесо	Чугун EN-GJL-250+Ni
Электрокабель	Неопрен H07RN/F
Вал	Нержавеющая сталь AISI431/Дуплекс
Уплот. кольца и манжета	Нитрил
Винты	Класс A4 - AISI316
Мех. Уплотнение	Карбид кремния/Карбид кремния.

SINGLE CHANNEL

Elettropompe sommergibili monocali 2 poli
 Submersible electric pumps single channel 2 poles
 Electropompe submersible monocal 2 pôles
 Tauchmotorpumpe mit Einkanalrad, 2-polig
 Bombas sumergibles monocal 2 polos
 Одноканальные погружные электронасосы 2 полюса

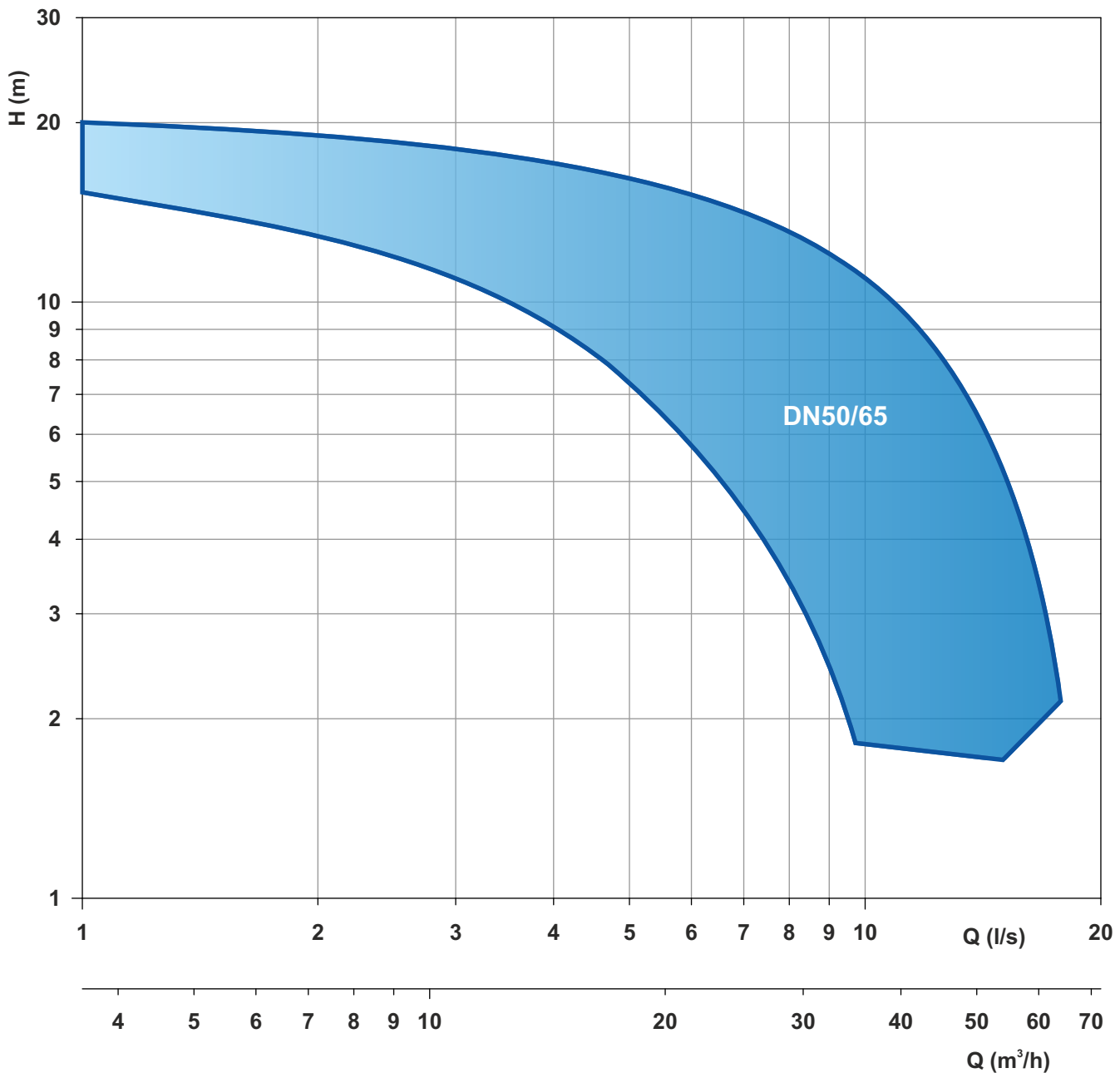

Le schede tecniche sono disponibili al sito www.faggiolatipumps.com
 Technical data sheets are available on our web site www.faggiolatipumps.com
 Les fiches techniques sont disponibles sur notre site web www.faggiolatipumps.com
 Technische Datenblätter finden Sie auf unserer Internetseite www.faggiolatipumps.com
 Las hojas de datos técnicas están disponibles en nuestro web site www.faggiolatipumps.com
 Технические спецификации доступны на веб-сайте www.faggiolatipumps.com



- Ghisa EN-GJL-250
- Fonte EN-GJL-250
- Hierro fundido EN-GJL-250

- Cast Iron EN-GJL-250
- Grauguss EN-GJL-250
- Чугун EN-GJL-250

Curva caratteristica - Performance curve - Courbe caractéristique
Kennlinie - Curva característica - Характеристическая кривая

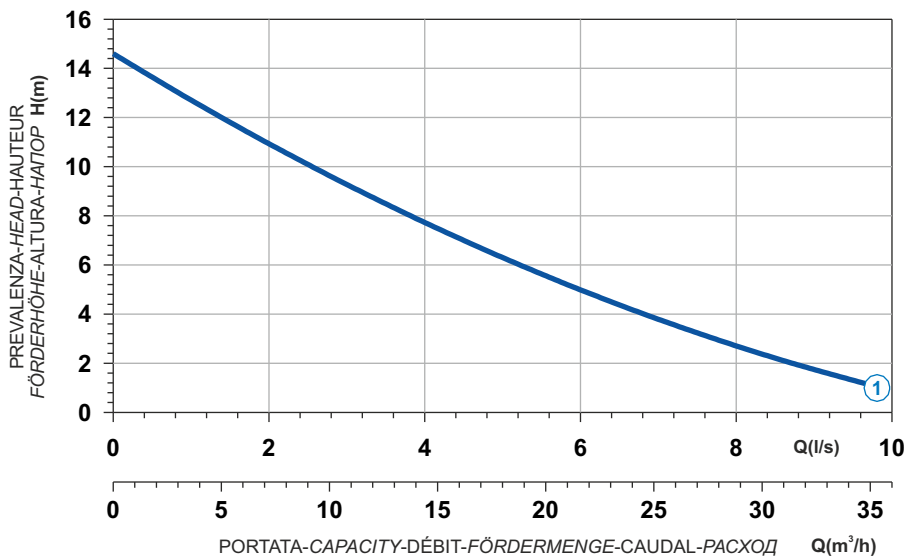



Power supply	1ph 230V 50Hz
R.P.M.	2850
Free passage (mm)	30
Discharge (mm)	DN 50
Max Weight (Kg)	31

Curve N°	Code	Type	MOTOR			ATEX code
			Rated power P2 (kW)	Rated current I (A)	Starting current Is (A)	
1	7000394	G272M1M2-K30AB1	1,4	8,4	31,1	-

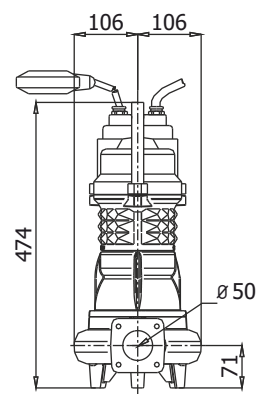
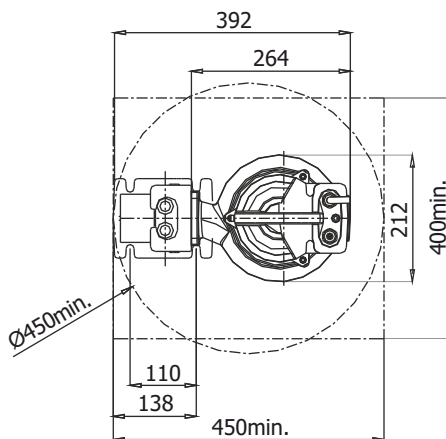
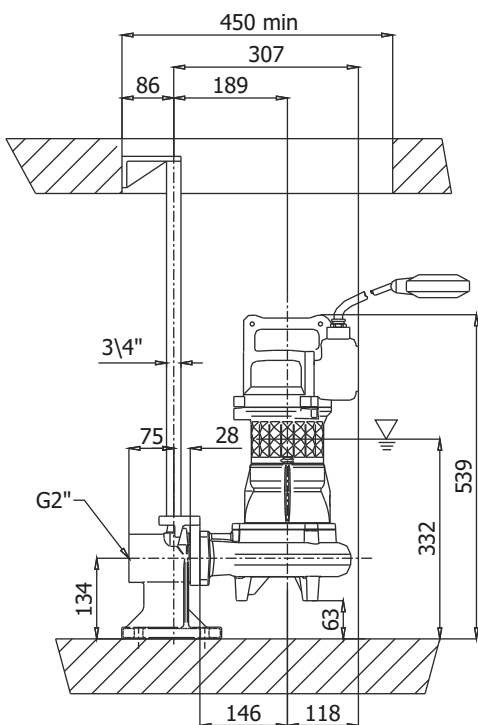
Dimensioni - Dimensions - Dimensions - Abmessungen - Dimensiones - Габариты (mm)





▽ LIVELLO MINIMO DI SOMMERSIBILITÀ
MINIMUM SUBMERSIBLE LEVEL
NIVEAU MINIMUM D'IMMERSION
MINDESTWASSERSTAND
NIVEL SUMERGIBLE MÍNIMO
МИНИМАЛЬНАЯ ГЛУБИНА ПОГРУЖЕНИЯ

 Ghisa EN-GJL-250
 Fonte EN-GJL-250
 Hierro fundido EN-GJL-250

 Cast Iron EN-GJL-250
 Grauguss EN-GJL-250
 Чугун EN-GJL-250

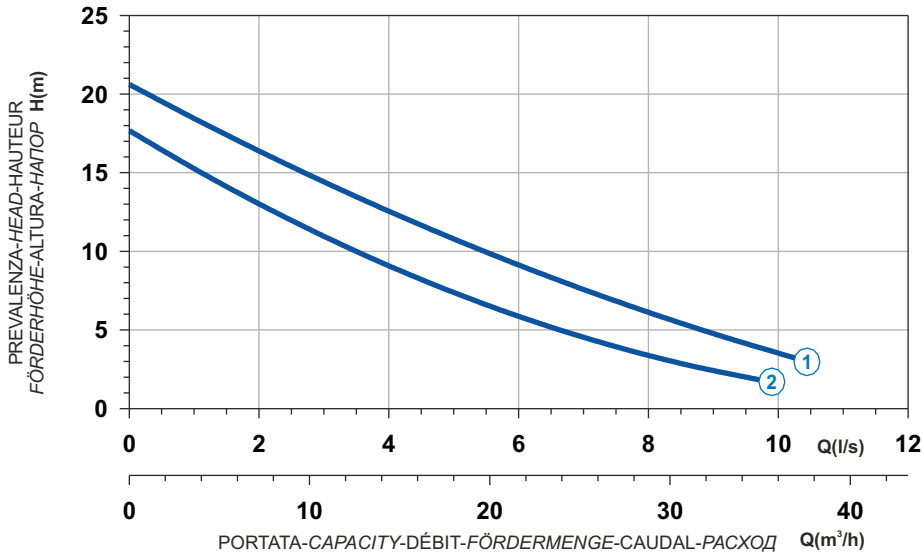
**Curva caratteristica - Performance curve - Courbe caractéristique
Kennlinie - Curva característica - Характеристическая кривая**



Curve N°	Code	Type	MOTOR			ATEX code 
			Rated power P2 (kW)	Rated current I (A)	Starting current Is (A)	
1	7000602	G272T1M1-K30AA0	1,9	3,5	20,7	-
2	7009016	G272T1M2-K30AA0	1,9	3,5	20,7	-

Power supply	3ph 400V 50Hz
R.P.M.	2850
Free passage (mm)	30
Discharge (mm)	DN 50
Max Weight (Kg)	31

Dimensioni - Dimensions - Dimensions - Abmessungen - Dimensiones - Габариты (mm)

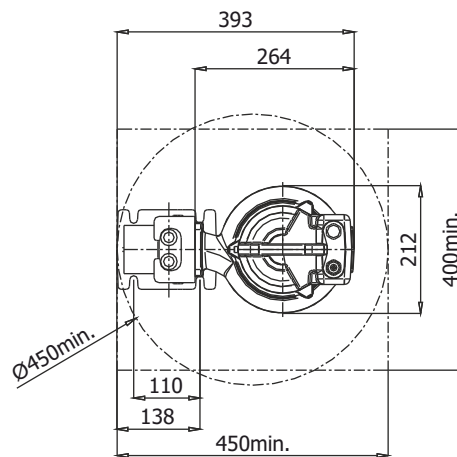
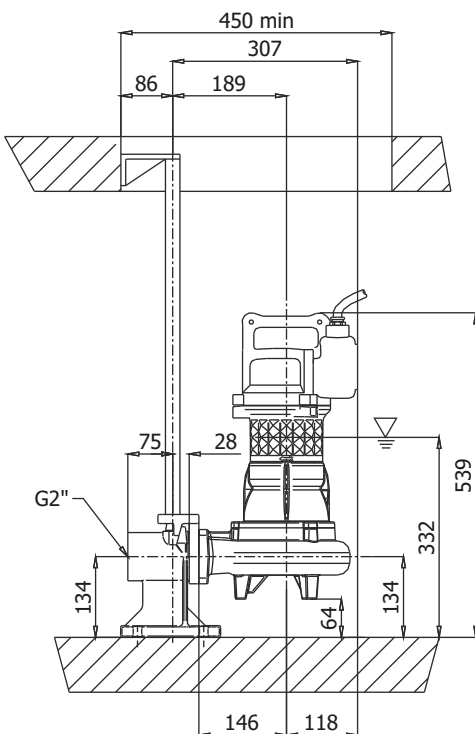

▽ LIVELLO MINIMO DI SOMMERGIBILITÀ
 MINIMUM SUBMERSIBLE LEVEL
 NIVEAU MINIMUM D'IMMERSION
 MINDESTWASSERSTAND
 NIVEL SUMERGIBLE MÍNIMO
 МИНИМАЛЬНАЯ ГЛУБИНА ПОГРУЖЕНИЯ

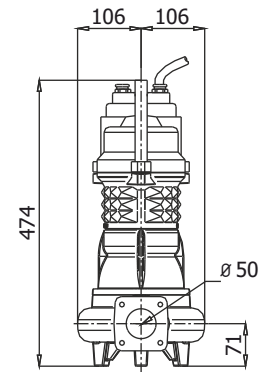



- Ghisa EN-GJL-250
- Fonte EN-GJL-250
- Hierro fundido EN-GJL-250

- Cast Iron EN-GJL-250
- Grauguss EN-GJL-250
- Чугун EN-GJL-250

Curva caratteristica - Performance curve - Courbe caractéristique
Kennlinie - Curva característica - Характеристическая кривая

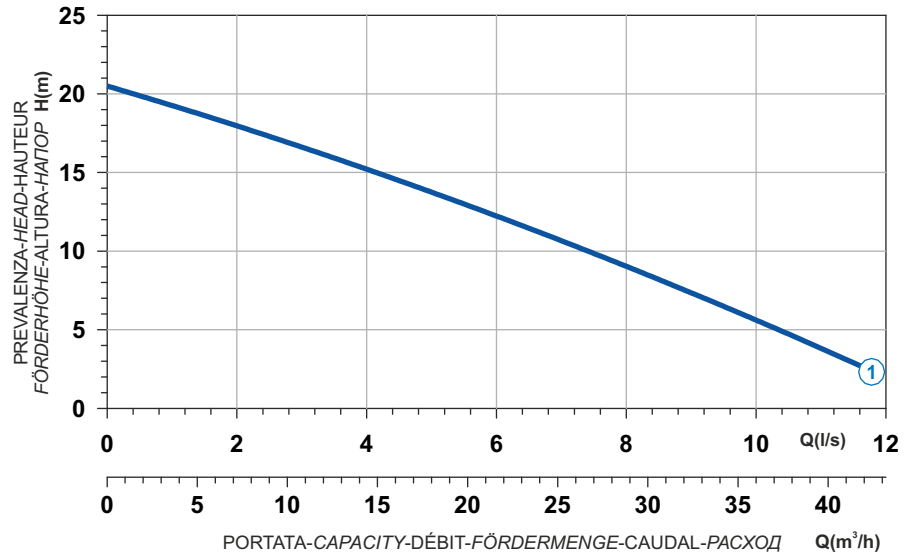



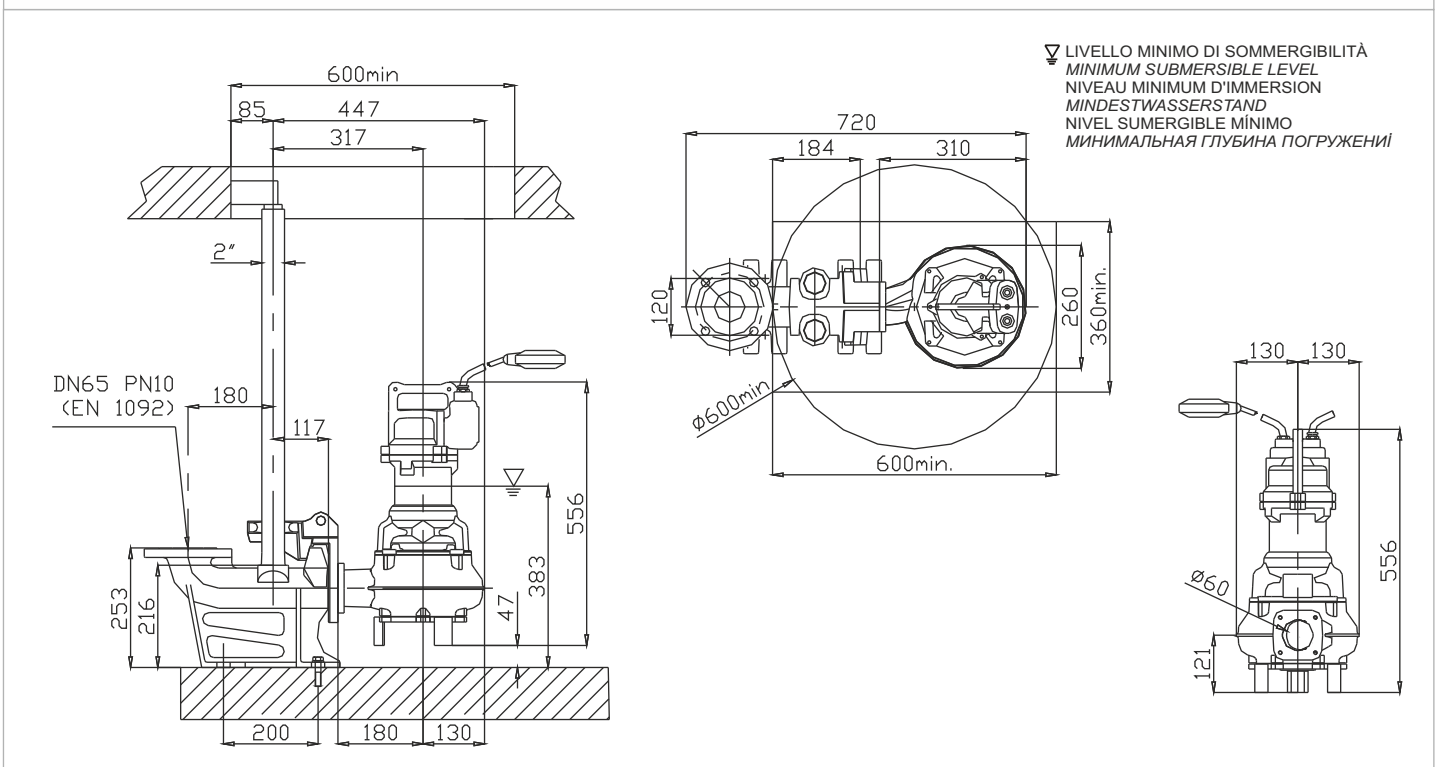

Power supply	1ph 230V 50Hz
R.P.M.	2850
Free passage (mm)	30
Discharge (mm)	DN 65
Max Weight (Kg)	42

Curve N°	Code	Type	MOTOR			ATEX code
			Rated power P2 (kW)	Rated current I (A)	Starting current Is (A)	
1	7002282	G271M1M1-L30AB1	1,5	9	33,3	7002812

Dimensioni - Dimensions - Dimensions - Abmessungen - Dimensiones - Габариты (mm)





 Ghisa EN-GJL-250
 Fonte EN-GJL-250
 Hierro fundido EN-GJL-250

 Cast Iron EN-GJL-250
 Grauguss EN-GJL-250
 Чугун EN-GJL-250

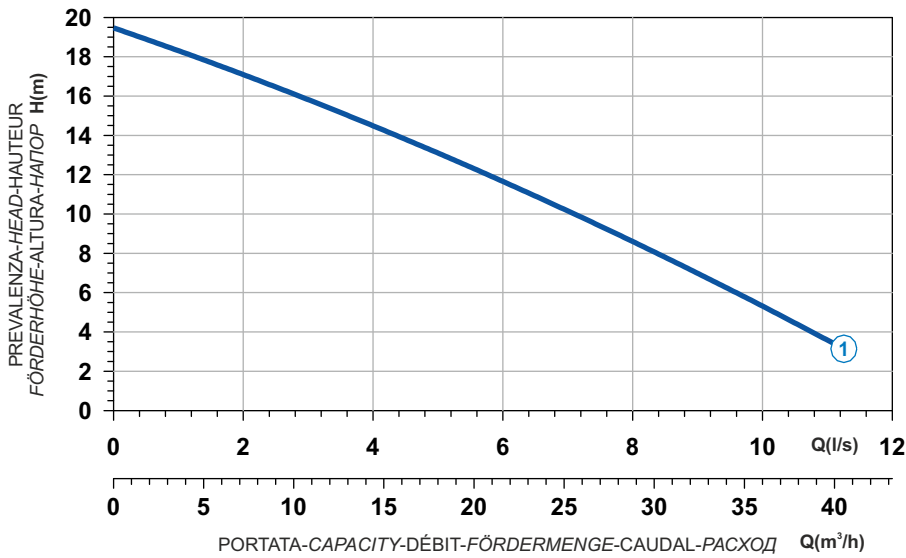

Curva caratteristica - Performance curve - Courbe caractéristique
Kennlinie - Curva característica - Характеристическая кривая



Curve N°	Code	Type	MOTOR			ATEX code 
			Rated power P2 (kW)	Rated current I (A)	Starting current Is (A)	
1	7002043	G271T1M1-L30AA0	1,6	3,1	15,2	7009113

Power supply	3ph 400V 50Hz
R.P.M.	2850
Free passage (mm)	30
Discharge (mm)	DN 65
Max Weight (Kg)	42

Dimensioni - Dimensions - Dimensions - Abmessungen - Dimensiones - Габариты (mm)

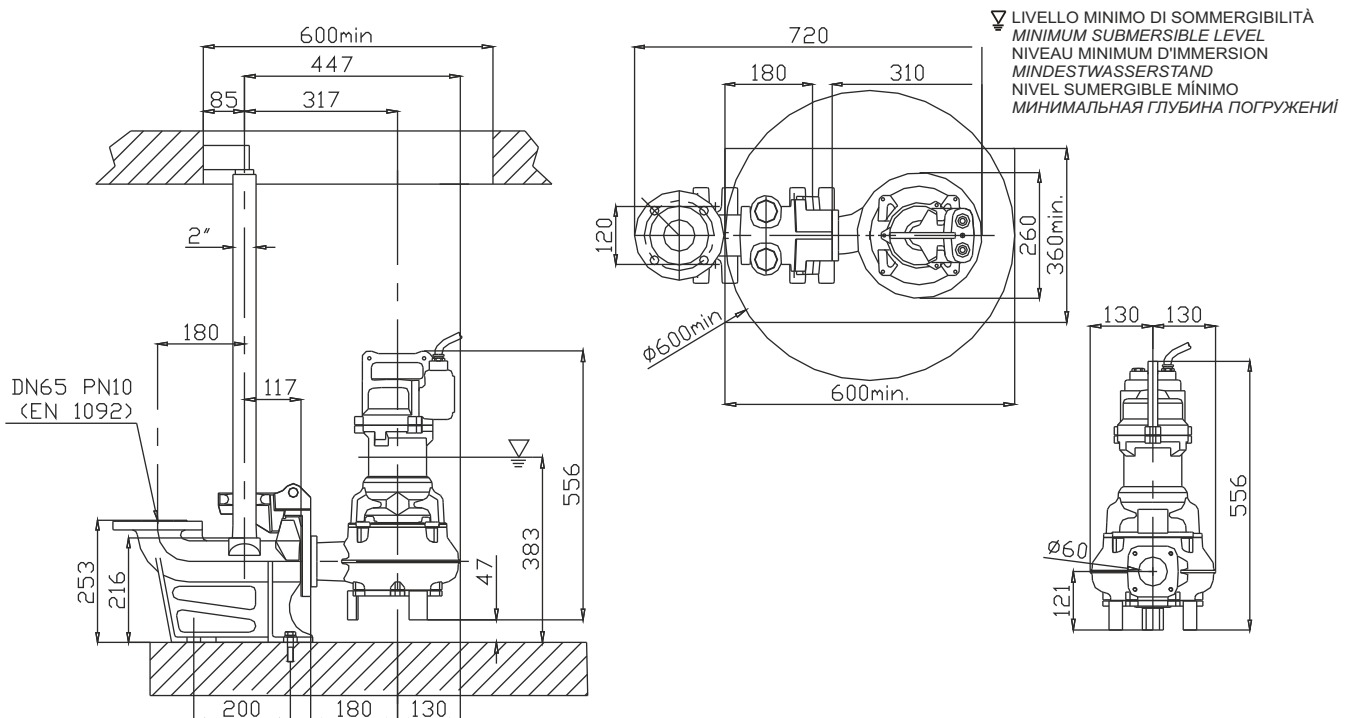



- Ghisa EN-GJL-250
- Fonte EN-GJL-250
- Hierro fundido EN-GJL-250

- Cast Iron EN-GJL-250
- Grauguss EN-GJL-250
- Чугун EN-GJL-250

Curva caratteristica - Performance curve - Courbe caractéristique
Kennlinie - Curva característica - Характеристическая кривая

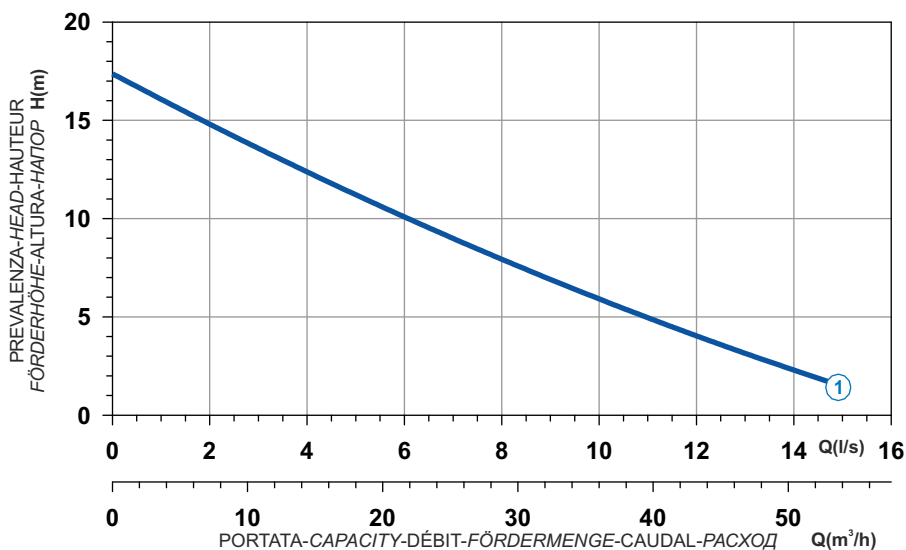



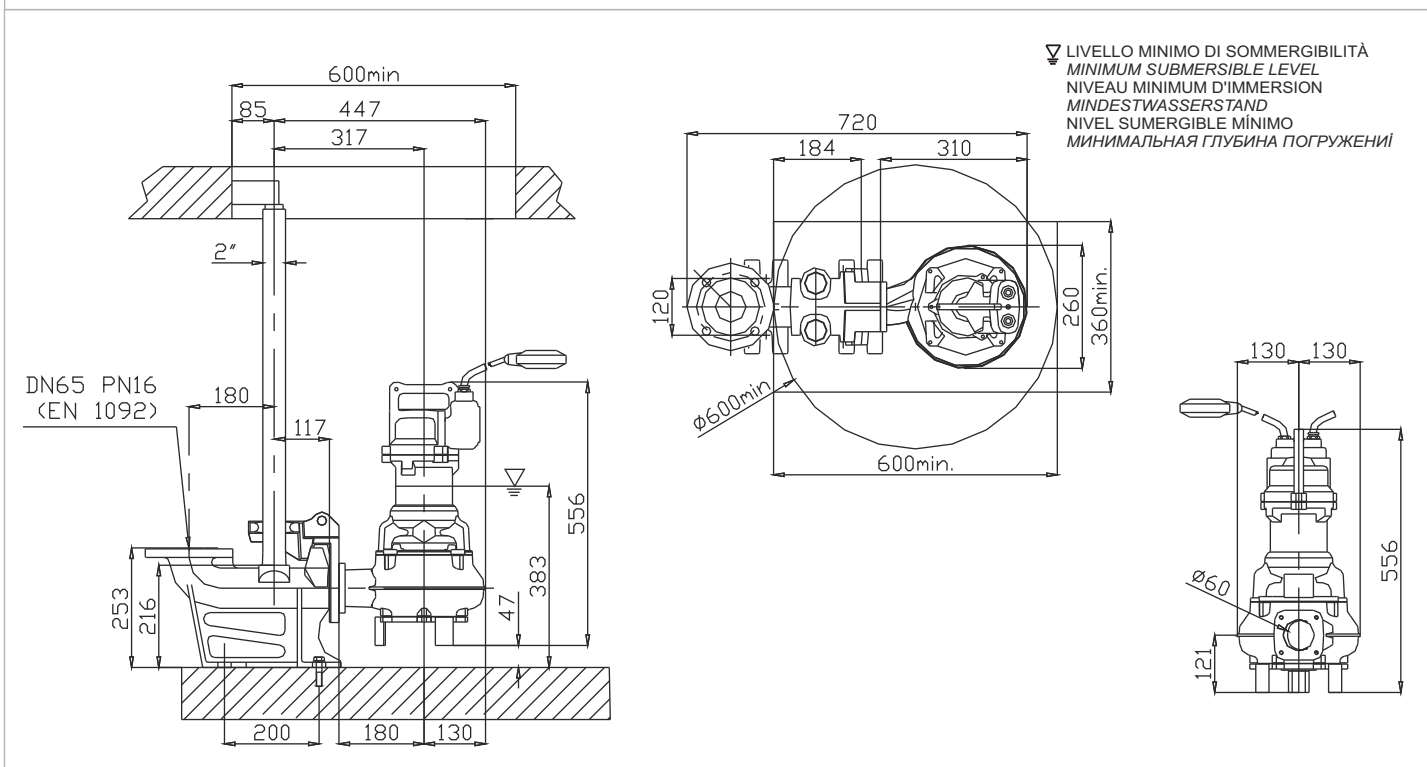

Power supply	1ph 230V 50Hz
R.P.M.	2850
Free passage (mm)	40
Discharge (mm)	DN 65
Max Weight (Kg)	45

Curve N°	Code	Type	MOTOR			ATEX code
			Rated power P2 (kW)	Rated current I (A)	Starting current Is (A)	
1	7005372	G271M1M2-L40AB1	1,9	11,4	62,7	7005851

Dimensioni - Dimensions - Dimensions - Abmessungen - Dimensiones - Габариты (mm)





 Ghisa EN-GJL-250
 Fonte EN-GJL-250
 Hierro fundido EN-GJL-250

 Cast Iron EN-GJL-250
 Grauguss EN-GJL-250
 Чугун EN-GJL-250

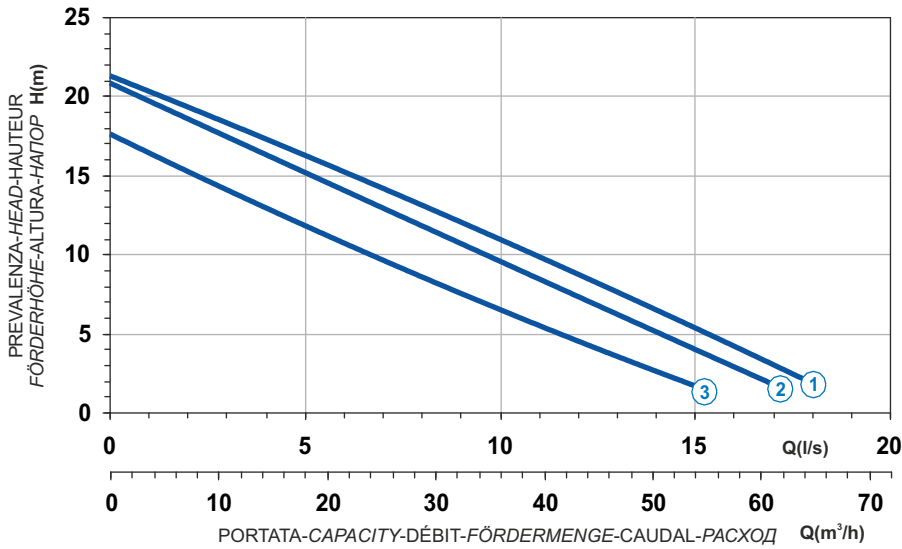

Curva caratteristica - Performance curve - Courbe caractéristique
Kennlinie - Curva característica - Характеристическая кривая



Curve N°	Code	Type	MOTOR			ATEX code 
			Rated power P2 (kW)	Rated current I (A)	Starting current Is (A)	
1	7005502	G271T1M4-L40AA0	2,8	5,2	30,7	7005867
2	7005029	G271T1M1-L40AA0	2,4	4,5	26,6	7005558
3	7005453	G271T1M2-L40AA0	2,4	4,5	26,6	7005757

Power supply	3ph 400V 50Hz
R.P.M.	2850
Free passage (mm)	40
Discharge (mm)	DN 65
Max Weight (Kg)	45

Dimensioni - Dimensions - Dimensions - Abmessungen - Dimensiones - Габариты (mm)

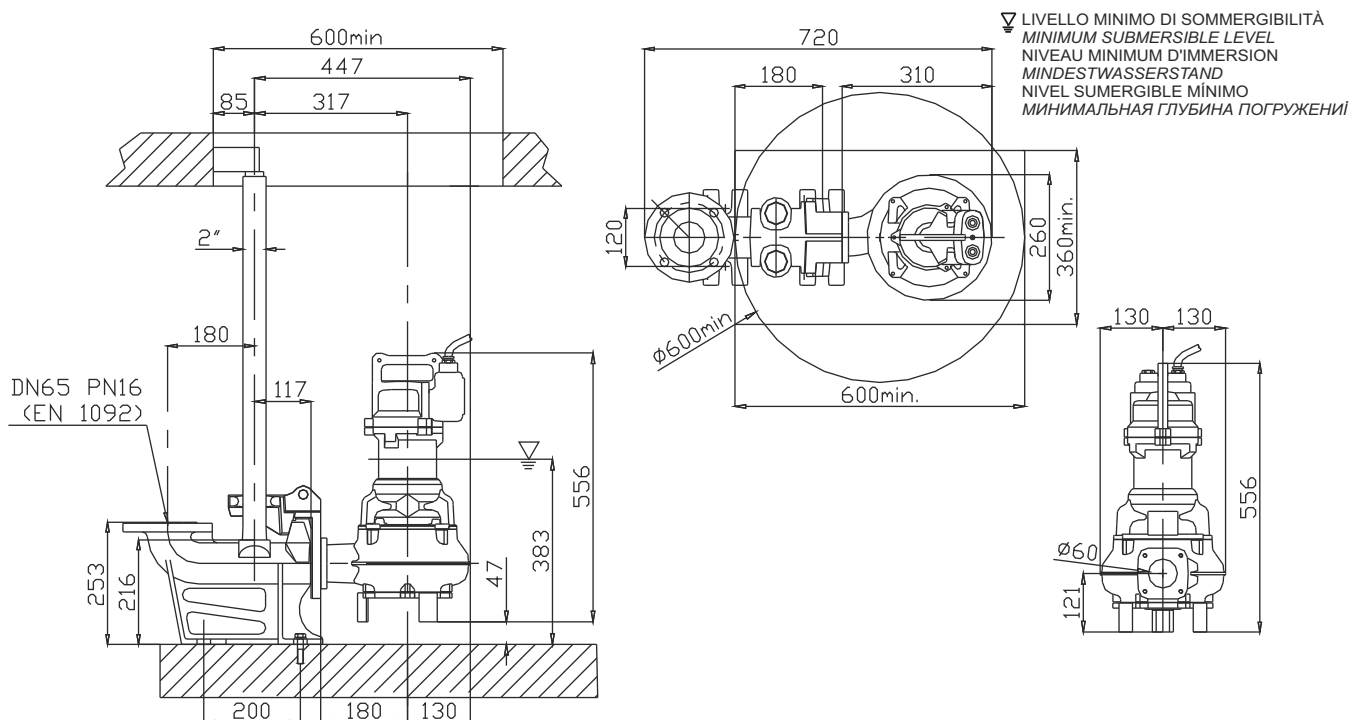

SINGLE CHANNEL



- Alberi** rettificati nelle sedi dei cuscinetti e della tenuta, sovradimensionati rispetto ai parametri standard di utilizzo, equilibrati dinamicamente.
- Motore** Asincrono trifase a gabbia di scoiattolo, classe d'isolamento H(180°C). A secco, raffreddato dal liquido circostante. Grado di protezione IP68. Il motore, è progettato per lavoro continuo o intermittente, con un massimo squilibrio di tensione tra le fasi del 5%.
- Cuscinetti** sovradimensionati, radiali a sfere lubrificati a vita esenti da manutenzione.
- Camera olio** L'olio lubrifica e raffredda le tenute, ed emulsiona eventuali infiltrazioni di acqua.
La pompa è dotata di due sistemi di tenuta per il perfetto isolamento tra il motore elettrico e il liquido pompato.
Tenuta superiore: Ceramica/Grafite.
- Tenuta inferiore:** meccanica, carburo di silicio.
- Le giranti** sono progettate per garantire un elevato rendimento idraulico e bassi consumi energetici, hanno grandi passaggi dei vani interpalari e dei diffusori, minimo numero di pale, speciale profilazione dei bordi palari e della lingua taglia-acqua del diffusore, per evitare la cattura dei materiali filamentosi.



- Les arbres** rectifiés dans les sièges des roulements et de la garniture mécanique, surdimensionnés par rapport aux paramètres standard d'utilisation, équilibrés dynamiquement.
- Moteur** asynchrone triphasé à cage d'écureuil, classe d'isolation H(180°C). À sec, refroidi par le liquide environnant. Degré de protection IP68. Le moteur est dessiné pour le service continu ou intermittent, régulièrement espacés et avec max. 5% de déséquilibre de tension entre les phases.
- Roulements** surdimensionnés, radiaux, à sphères lubrifiées à vie, exemptes d'entretien.
- Chambre huile** L'huile lubrifie et refroidit les garnitures mécaniques et émulsionne les infiltrations d'eau éventuelles. Deux garnitures mécaniques assurent la parfaite isolation entre le moteur électrique et le liquide pompé.
Garniture supérieure: céramique/carbone.
- Garniture inférieure:** mécanique, carbure de silicium.
- Les roues** sont dessinées pour garantir un rendement hydraulique élevé et des basses consommations énergétiques, elles ont des grands passages libres, un nombre minimum de pales, un dessin spécial du profil des pales et de la langue taille-eaux, afin d'éviter d'encrasser la pompe par des filaments.



- Ejes** rectificado en la base de los cojinetes y base de la mecánica, sobredimensionado respecto a los parámetros estándar de uso y equilibrados dinámicamente.
- Motor** asincrónico trifásico con jaula, aislamiento H(180°C). En seco, enfriado por el líquido. Grado de protección IP68. El motor, esta preparado para trabajar continuamente o intermitentemente, con un máximo desequilibrio de tensión entre las fases del 5%.
- Cojinetes** sobredimensionados, radiales y esferas lubricados indefinidamente, sin necesidad de mantenimiento.
- Cámara de aceite** que lubrifica y enfría los precintos y emulsiona las eventuales infiltraciones de agua.
La bomba está dotada de dos sistemas de sellado para el perfecto aislamiento entre el motor eléctrico y el líquido bombeado.
Sellado/precintado superior: mecánica, grafito/cerámica.
- Sellado/precintado inferior:** mecánica, carburo y silicio.
- Los impulsores** han sido proyectados para garantizar una alta eficacia hidráulica y un bajo absorbitamiento de energía, tienen grandes pasos libres entre las palas y en los difusores, número mínimo de palas, perfil especial de los bordes de las palabras y del separador del flujo en el difusor, para evitar de coger los materiales filamentosos.



- Shafts** grided down in ball bearings and mechanical seals seats, over-dimensioned respect to standard parameters of use.
- Motor** asynchronous threephase squirrel cage type, insulation class H(180°C). Dry motor, cooled by surrounding liquid. Protection degree IP 68. The motor is projected for continuous or intermittent operation, with 5% maximum voltage unbalance between phases.
- Ball bearings** overdimensioned, life lubricated, maintenance free.
- Oil chamber** oil lubricates and cools the seals and emulsifies eventual water infiltrations.
This electric pump has two types of seals for a perfect insulation between the electric motor and the pumped liquid.
Upper seal: Ceramic/Graphite.
- Lower seal:** mechanical, silicon carbide.
- Impellers** are projected in order to guarantee and assure an high hydraulic efficiency and low power consumption, they have big inter-blades and diffuser free passages, minimum blades number, special blades design, especially diffusers' water-cutter blades designed to avoid filamentous materials catching.



- Welle** Lagerung und Abdichtung durch überdimensionierte Wälzlager bzw. Dichtsträger.
- Motor** Asynchroner Drehstrom-Käfigläufermotor, Isolationsklasse H (180°C). Trockener Motor, gekühlt durch Umgebungsflüssigkeit. Schutzart IP 68. Der Motor ist für kontinuierlichen oder intermittierenden Betrieb mit einer maximalen Spannungsunsymmetrie von 5 % zwischen den Phasen ausgelegt.
- Wälzlager** überdimensioniert, dauergeschmiert und wartungsfrei.
- Ölkammer** Öl schmiert und kühlt die Dichtungen und emulgiert bei evtl. Leckage.
Doppeltwirkendes Dichtsystem garantiert optimale Abdichtung zwischen Motor und Fördermedium
Obere Dichtung: Gleitringdichtung Kohle / Keramik.
- Untere Dichtung:** Gleitringdichtung Siliziumkarbid.
- Laufrad** konstruiert für max. hydraulischen Wirkungsgrad und geringer Leistungsaufnahme. Große Zwischenräume und tottraumfreie Passagen, spezielle Schaufelformen und Diffusorkanäle sorgen für eine verstopfungsfreie Förderung.



- Валы**, отшлифованные в местах посадки подшипников и уплотнения, рассчитанные с запасом относительно стандартных рабочих параметров, динамически отбалансированы.
- Трехфазный** Двигатель асинхронный трехфазный с короткозамкнутым ротором, класс изоляции H(180°C). Сухой двигатель, охлаждаемый окружающей жидкостью. Степень защиты IP 68. Двигатель рассчитан на непрерывную или повторно-кратковременную работу с асимметрией напряжения между фазами не более 5%.
- Подшипники** рассчитаны с запасом, радиального типа с шариками со смазкой на весь срок службы, не требующие тех. обслуживания.
- Масляная** камера служит для смазки и охлаждения прокладок, а также для эмульгирования просочившейся воды. Насос снабжен двумя системами герметизации для обеспечения идеальной изоляции между электродвигателем и перекачиваемой жидкостью.
Верхнее уплотнение: керамика/графит.
- Нижнее уплотнение:** механическое, карбид кремния.
- Рабочие** колеса спроектированы для обеспечения высокого гидравлического КПД и низкого энергопотребления. Они имеют большие проходы в зонах между лопастями и диффузорах, минимальное количество лопастей, специальный профиль кромок лопастей и язычок для разреза воды на диффузоре во избежание удержания волокнистых материалов.

SINGLE CHANNEL

Elettropompe sommergibili monocali 4 poli
 Submersible electric pumps single channel 4 poles
 Electropompe submersible monocal 4 pôles
 Tauchmotorpumpe mit Einkanalrad, 4-polig
 Bombas sumergibles monocal 4 polos
 Одноканальные погружные электронасосы 4 полюса

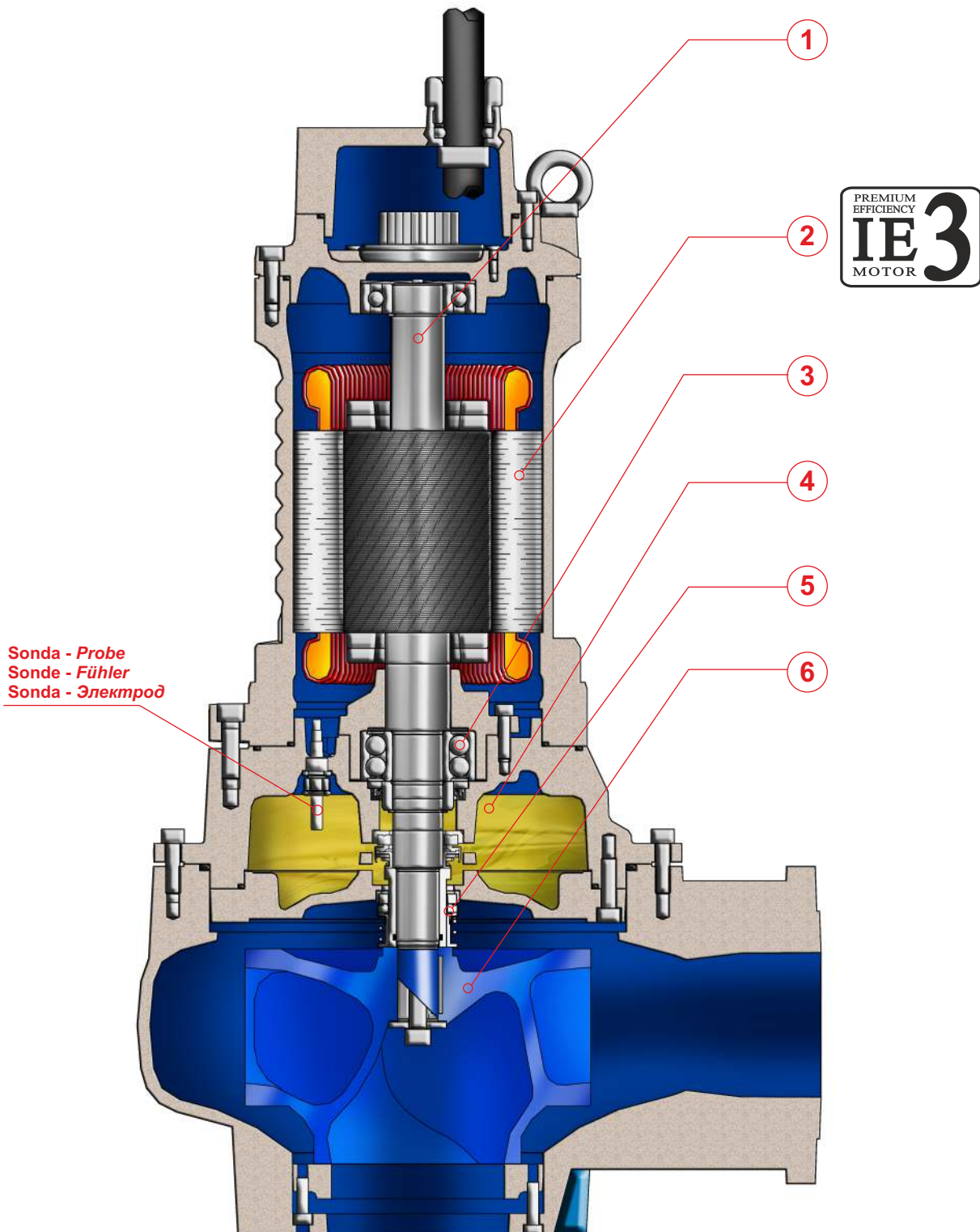

SINGLE CHANNEL

**IMPIEGHI**

Le elettropompe sommergibili monocali sono utilizzate prevalentemente per il pompaggio di acque cariche e luride grigliate. In particolare per lo svuotamento di pozzi neri, pozzi di raccolta liquami da fosse biologiche e pozzi di raccolta acque usate in generale.

PARTICOLARITÀ COSTRUTTIVE

Elettropompe sommergibili di robusta e compatta costruzione, motori elettrici alloggiati in vano a tenuta stagna, collegati mediante alberi di lunghezze ridotte alle giranti situate in voluta tramite interposizione di camera olio tra parte idraulica e motore elettrico.

MATERIALI

Fusioni principali	Ghisa EN-GJL-250
Girante	Ghisa EN-GJL-250+Ni
Cavo elettrico	Neoprene H07RN/F
Albero	Acciaio inossidabile AISI 431 / Duplex
O-rings e paraolio	Nitrile
Bullonerie	Classe A4 - AISI316
Tenuta meccanica	Carburo di silicio / Carburo di silicio

**APPLICATIONS**

Les pompes submersibles monocanal sont utilisées principalement pour le pompage d'eaux chargées et usées grillagées. En particulier pour la vidange de puisard noir, puisard de recueillement des eaux usées de fosses biologiques et eaux usées en général.

PARTICULARITÉ DE CONSTRUCTION

Pompes submersibles robustes et compactes, moteurs électriques logés en enceinte étanche, reliés par des arbres de longueurs réduites aux roues, avec interposition d'une chambre à huile entre la partie hydraulique et le moteur électrique.

MATÉRIAUX

Moulures principales	Fonte EN-GJL-250
Roue	Fonte EN-GJL-250+Ni
Câble électrique	Néoprène H07RN/F
Arbre	Acier inoxydable AISI 431 / Duplex
O-ring et joints	Nitrile
vis	Classe A4 - AISI316
Garniture mécanique	Carb. de silicium / carbure de silicium

**UTILIZACION**

Las bombas sumergibles monocanales se utilizan especialmente para bombear aguas cargadas ya filtradas. En particular para vaciar pozos negros, pozos de recogida de líquidos procedentes de fosas biológicas y pozos de recogida de aguas utilizada en general.

DIFERENCIAS PRINCIPALES

Son bombas sumergibles de robusta y compacta construcción, motores eléctricos situados en compartimento separado, conectadas mediante ejes cortos con los impulsores interpuestos con una cámara de aceite entre la parte hidráulica i el motor eléctrico.

MATERIALES

Aleaciones principales	Hierro Fundido EN-GJL-250
Impulsor (turbina)	Hierro Fundido EN-GJL-250+Ni
Cable eléctrico	Neopreno H07RN/F
Eje	Acero inoxidable AISI 431 / Duplex
Anillo de sellados y O-Rings	Nitrilo
Tornillos	Clase A4 - AISI316
Sello mecánico	Carburo de silicio / Carburo de silicio

**APPLICATION**

Submersible electric pumps single channel are used prevalently for the lifting of non corrosive dirty waters also with solid bodies in suspension. In particular for screened waste water and drainage of places subject to flooding, crude and activated sludge.

CONSTRUCTION DATA

Submersible electric pumps, robust in construction, watertight electric motors accommodated in compartment, connected, by shafts of reduced lengths, to the impellers situated at the pump casing by the interposition of oil chamber between the hydraulic side and the electric motor.

MATERIALS

Motor housing	Cast iron EN-GJL-250
Impeller	Cast-iron EN-GJL-250+Ni
Electric cable	Neoprene H07RN/F
Shaft	Stainless Steel AISI 431 / Duplex
O-rings and lip seal	Nitrile
Bolts	A4 - AISI316 class
Mechanical seal	Silicon Carbide / Silicon Carbide

**EINSATZBEREICHE**

Tauchmotorpumpen mit Einkanalrad werden vorwiegend zur Förderung von Abwasser mit Schwebstoffen eingesetzt. Speziell geeignet für vorgefiltertes Abwasser und dem Einsatz in überflutungsgefährdeten Gebieten, zur Förderung von schlammhaltigen Medien.

AUSFÜHRUNG

Robuste Tauchmotorpumpe mit wasserdichtem Motor, kompakte Bauart, Laufrad im Pumpengehäuse durch Ölkammer zum Motor getrennt.

WERKSTOFFE

Motorgehäuse	Grauguss EN-GJL-250
Laufrad	Grauguss EN-GJL-250+Ni
Anschlusskabel	Neoprene H07RN/F
Welle	Edelstahl AISI 431 / Duplex
Wellendichtring und O-Ringe	Nitril
Schrauben	Edelstahl A4 - AISI316
Gleitringdichtung	Siliziumkarbid / Siliziumkarbid

**ОБЛАСТЬ ПРИМЕНЕНИЯ**

Одноканальные погружные электронасосы используются, в основном, для перекачки средне- и сильнозагрязненных сточных вод после грубой мех. очистки. В частности, для опорожнения канализационных ям и накопительных емкостей для сточных вод.

КОНСТРУКЦИОННЫЕ ОСОБЕННОСТИ

Погружные электронасосы с прочной и компактной конструкцией. Электродвигатели размещены в секции с герметичным уплотнением и соединены через валы небольшой длины с рабочими колесами, расположенными в гидравлической камере. Валы проходят через масляную камеру между гидравликой и электродвигателем.

МАТЕРИАЛЫ

Основные литые компоненты	Чугун EN-GJL-250
Рабочее колесо	Чугун EN-GJL-250+Ni
Электрокабель	Неопрен H07RN/F
Вал	Нержавеющая сталь AISI431/Дуплекс
Уплот. кольца и манжета	Нитрил
Винты	Класс A4 - AISI316
Мех. Уплотнение	Карбид кремния/Карбид кремния

SINGLE CHANNEL

Elettropompe sommergibili monocali 4 poli
 Submersible electric pumps single channel 4 poles
 Electropompe submersible monocal 4 pôles
 Tauchmotorpumpe mit Einkanalrad, 4-polig
 Bombas sumergibles monocal 4 polos
 Одноканальные погружные электронасосы 4 полюса

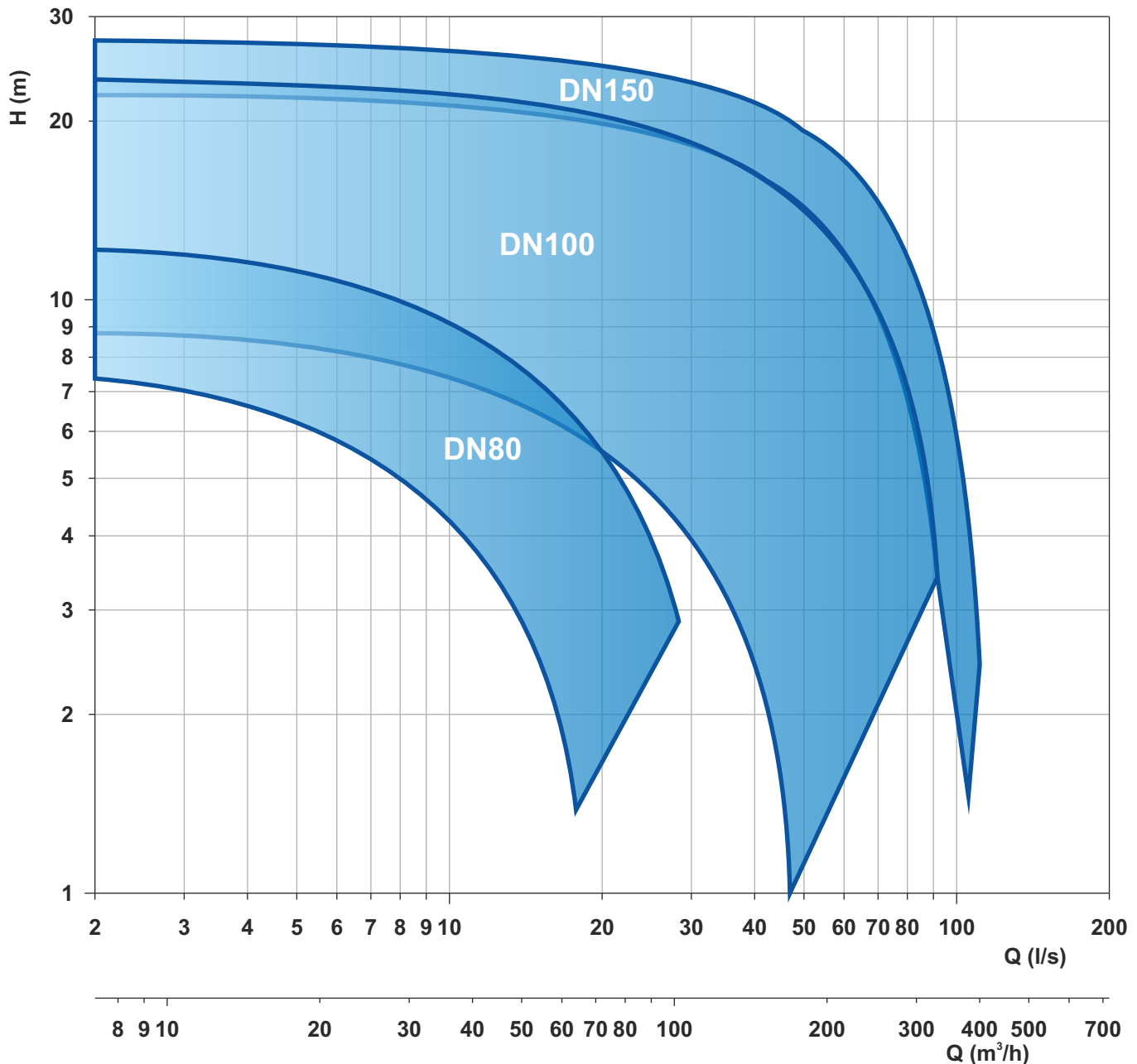

Le schede tecniche sono disponibili al sito www.faggiolatipumps.com
 Technical data sheets are available on our web site www.faggiolatipumps.com
 Les fiches techniques sont disponibles sur notre site web www.faggiolatipumps.com
 Technische Datenblätter finden Sie auf unserer Internetseite www.faggiolatipumps.com
 Las hojas de datos técnicas están disponibles en nuestro web site www.faggiolatipumps.com
 Технические спецификации доступны на веб-сайте www.faggiolatipumps.com



- Ghisa EN-GJL-250
- Fonte EN-GJL-250
- Hierro fundido EN-GJL-250

- Cast Iron EN-GJL-250
- Grauguss EN-GJL-250
- Чугун EN-GJL-250

Curva caratteristica - Performance curve - Courbe caractéristique
Kennlinie - Curva característica - Характеристическая кривая

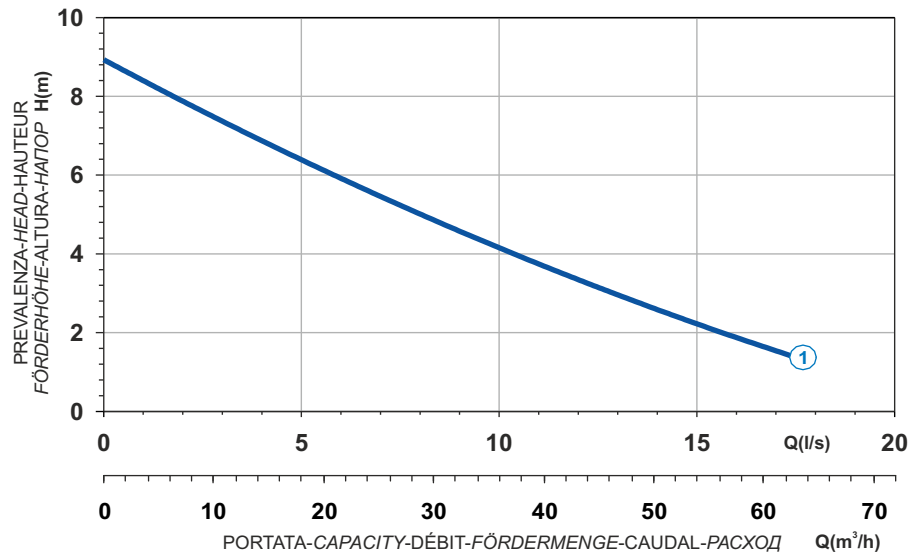



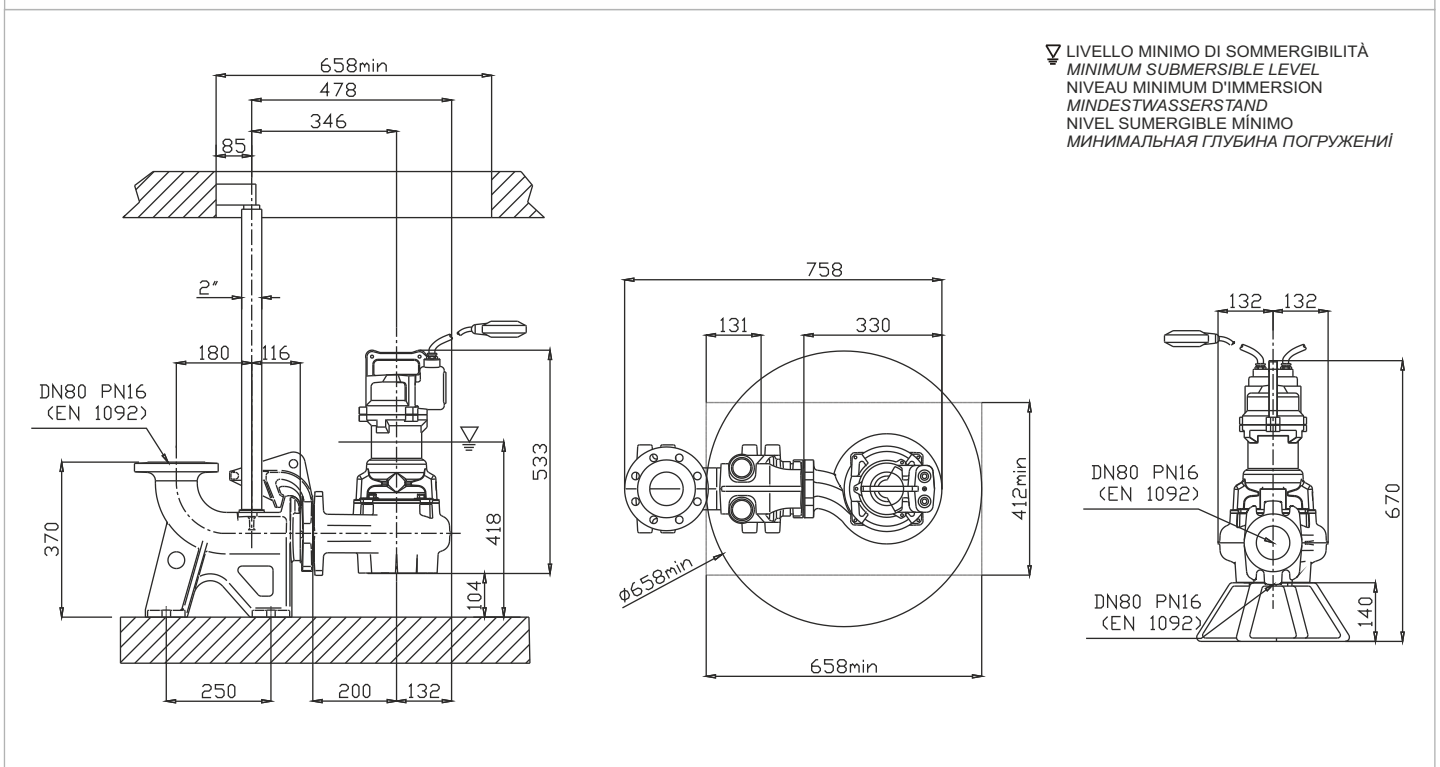

Power supply	1ph 230V 50Hz
R.P.M.	1450
Free passage (mm)	65
Discharge (mm)	DN 80
Max Weight (Kg)	49

Curve N°	Code	Type	MOTOR			ATEX code
			Rated power P2 (kW)	Rated current I (A)	Starting current Is (A)	
1	7004188	G471M1M1-M65AB1	1,2	6,9	34,5	7004187

Dimensioni - Dimensions - Dimensions - Abmessungen - Dimensiones - Габариты (mm)



 Ghisa EN-GJL-250
 Fonte EN-GJL-250
 Hierro fundido EN-GJL-250

 Cast Iron EN-GJL-250
 Grauguss EN-GJL-250
 Чугун EN-GJL-250

Curva caratteristica - Performance curve - Courbe caractéristique
Kennlinie - Curva característica - Характеристическая кривая

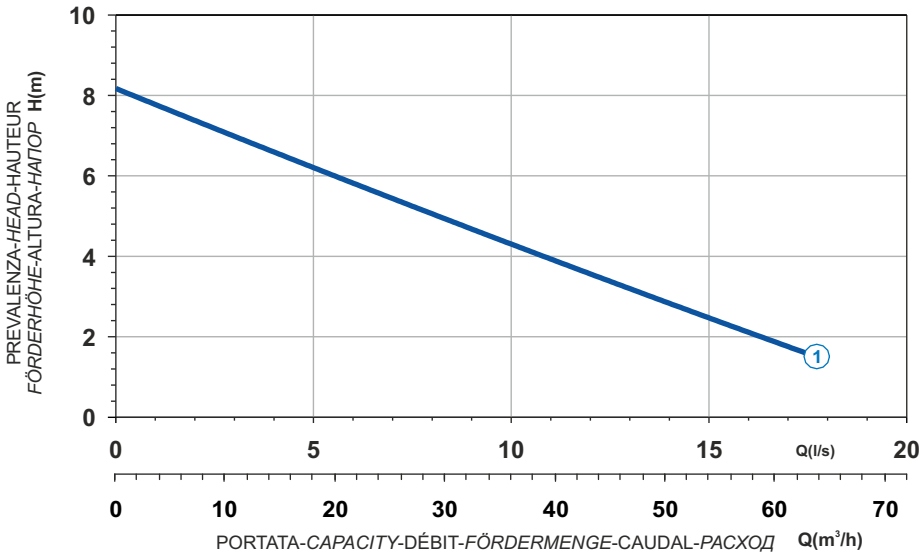

Curve N°	Code	Type	MOTOR			ATEX code 
			Rated power P2 (kW)	Rated current I (A)	Starting current Is (A)	
1	7003550	G471T1M1-M65AA0	1,6	3,1	14	7004189

Power supply	3ph 400V 50Hz
R.P.M.	1450
Free passage (mm)	65
Discharge (mm)	DN 80
Max Weight (Kg)	49

Dimensioni - Dimensions - Dimensions - Abmessungen - Dimensiones - Габариты (mm)

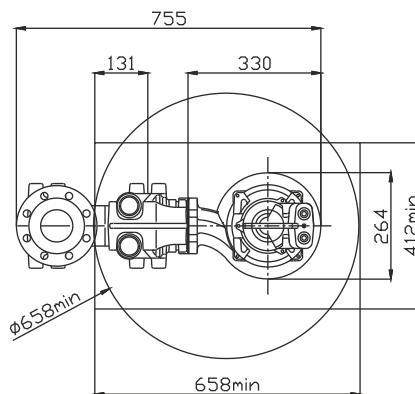
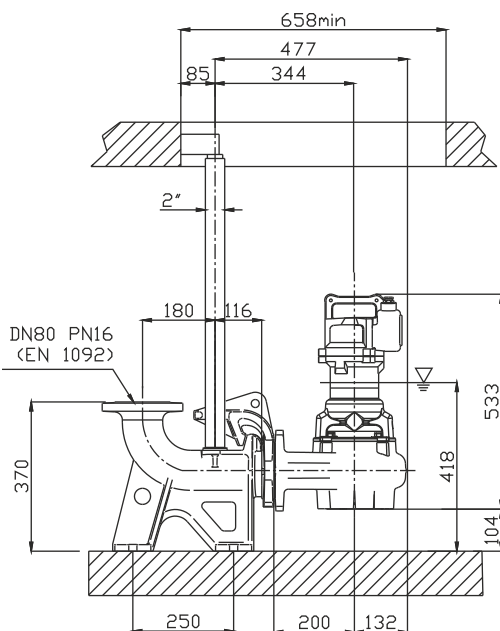

▽ LIVELLO MINIMO DI SOMMERGIBILITÀ
 MINIMUM SUBMERSIBLE LEVEL
 NIVEAU MINIMUM D'IMMERSION
 MINDESTWASSERSTAND
 NIVEL SUMERGIBLE MÍNIMO
 МИНИМАЛЬНАЯ ГЛУБИНА ПОГРУЖЕНИЯ

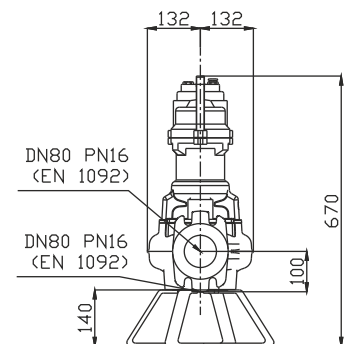



- Ghisa EN-GJL-250
- Fonte EN-GJL-250
- Hierro fundido EN-GJL-250

- Cast Iron EN-GJL-250
- Grauguss EN-GJL-250
- Чугун EN-GJL-250

Curva caratteristica - Performance curve - Courbe caractéristique
Kennlinie - Curva característica - Характеристическая кривая

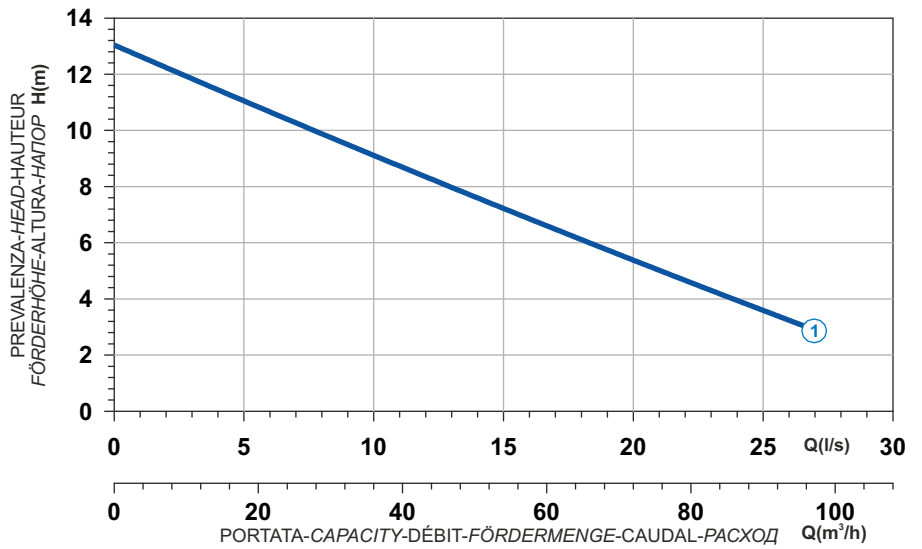





Power supply	3ph 400V 50Hz
R.P.M.	1450
Free passage (mm)	76
Discharge (mm)	DN 80
Max Weight (Kg)	67

Curve N°	Code	Type	MOTOR			ATEX code
			Rated power P2 (kW)	Rated current I (A)	Starting current Is (A)	
1	7003521	G409T1M1-M76AA0	2,8	5,4	24,3	7008262

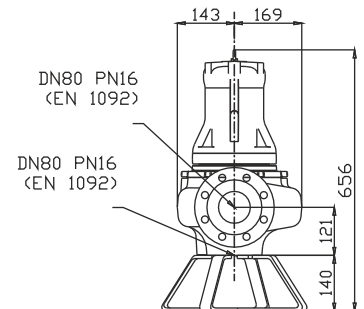
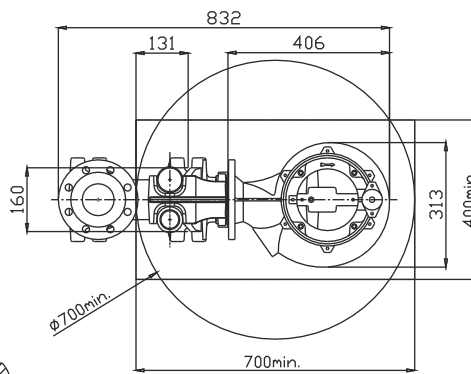
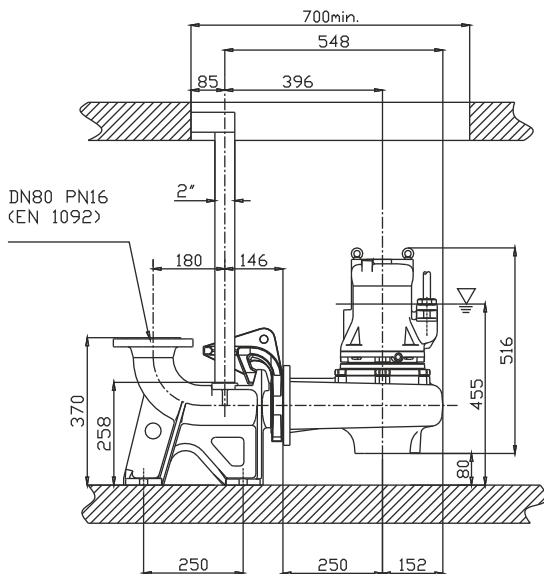
Dimensioni - Dimensions - Dimensions - Abmessungen - Dimensiones - Габариты (mm)

▽ LIVELLO MINIMO DI SOMMERSIBILITÀ
MINIMUM SUBMERSIBLE LEVEL
NIVEAU MINIMUM D'IMMERSION
MINDESTWASSERSTAND
NIVEL SUMERGIBLE MÍNIMO
МИНИМАЛЬНАЯ ГЛУБИНА ПОГРУЖЕНИЯ



 Ghisa EN-GJL-250
 Fonte EN-GJL-250
 Hierro fundido EN-GJL-250

 Cast Iron EN-GJL-250
 Grauguss EN-GJL-250
 Чугун EN-GJL-250

Curva caratteristica - Performance curve - Courbe caractéristique
Kennlinie - Curva característica - Характеристическая кривая

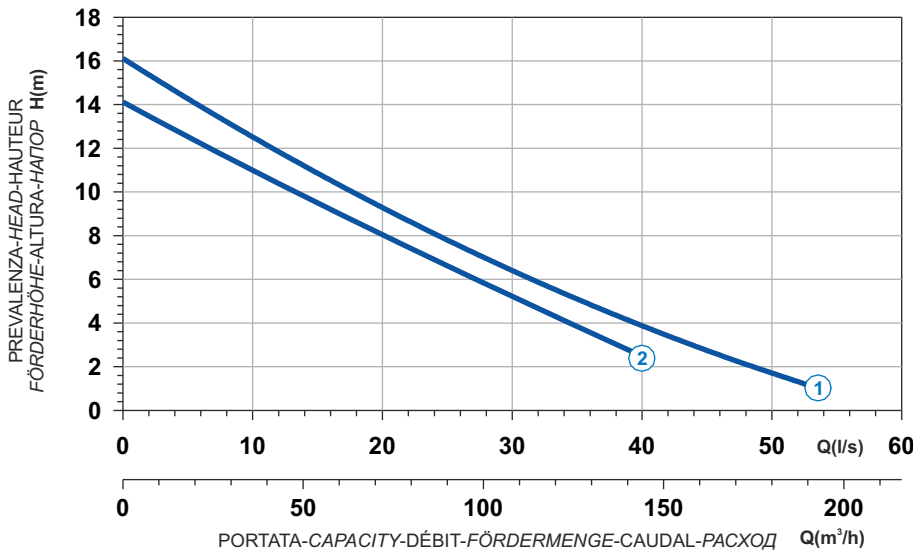

Curve N°	Code	Type	MOTOR			ATEX code 
			Rated power P2 (kW)	Rated current I (A)	Starting current Is (A)	
1	7000112	G410R1M1-P78AA2	3,9	7,9	39,5	7008609
2	7000203	G410R1M2-P78AA2	3,9	7,9	39,5	7002797

Power supply	3ph 400/690V 50Hz
R.P.M.	1450
Free passage (mm)	78
Discharge (mm)	DN 100
Max Weight (Kg)	117

Dimensioni - Dimensions - Dimensions - Abmessungen - Dimensiones - Габариты (mm)

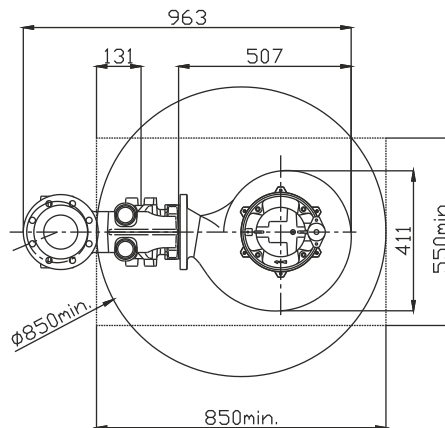
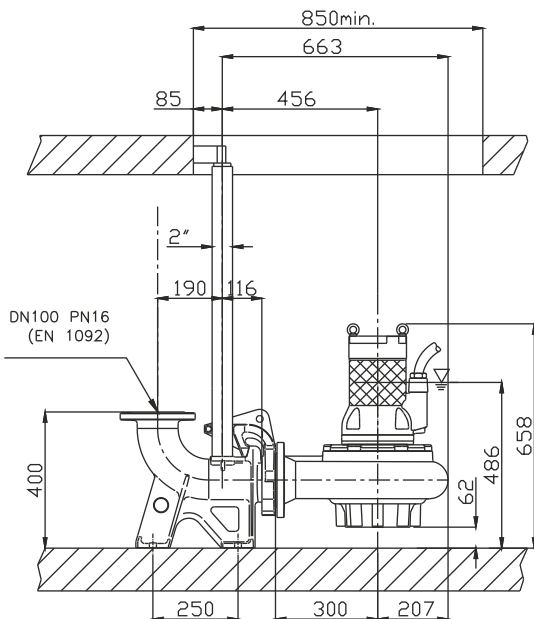

▽ LIVELLO MINIMO DI SOMMERGIBILITÀ
 MINIMUM SUBMERSIBLE LEVEL
 NIVEAU MINIMUM D'IMMERSION
 MINDESTWASSERSTAND
 NIVEL SUMERGIBLE MÍNIMO
 МИНИМАЛЬНАЯ ГЛУБИНА ПОГРУЖЕНИЯ

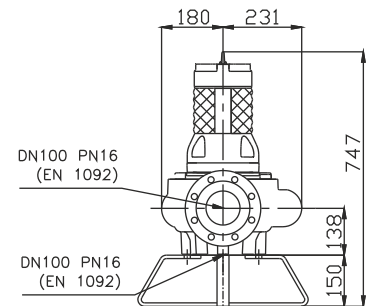



Ghisa EN-GJL-250
 Fonte EN-GJL-250
 Hierro fundido EN-GJL-250

Cast Iron EN-GJL-250
 Grauguss EN-GJL-250
 Чугун EN-GJL-250

Curva caratteristica - Performance curve - Courbe caractéristique
 Kennlinie - Curva característica - Характеристическая кривая

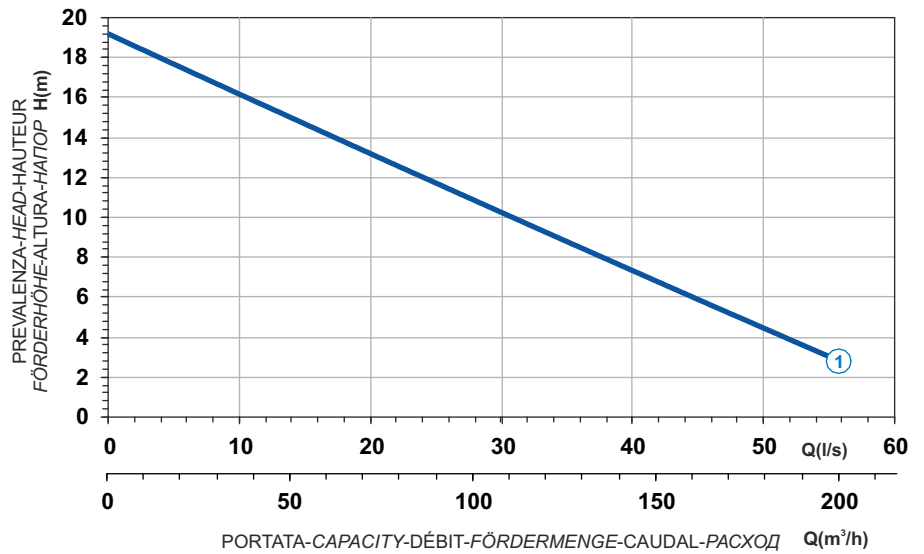

Power supply	3ph 400/690V 50Hz
R.P.M.	1450
Free passage (mm)	78
Discharge (mm)	DN 100
Max Weight (Kg)	170



Curve N°	Code	Type	MOTOR			ATEX code
			Rated power P2 (kW)	Rated current I (A)	Starting current Is (A)	
1	7005181	G411R1M1-P78AA2	7,1	13,5	79,7	7007499

Dimensioni - Dimensions - Dimensions - Abmessungen - Dimensiones - Габариты (mm)

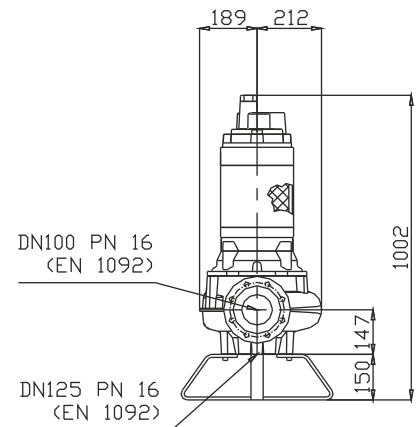
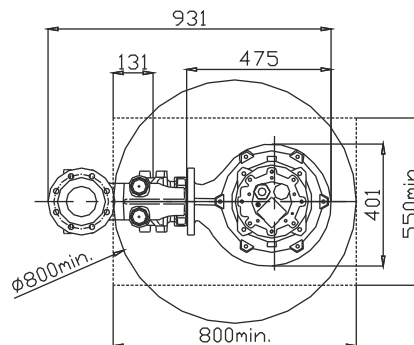
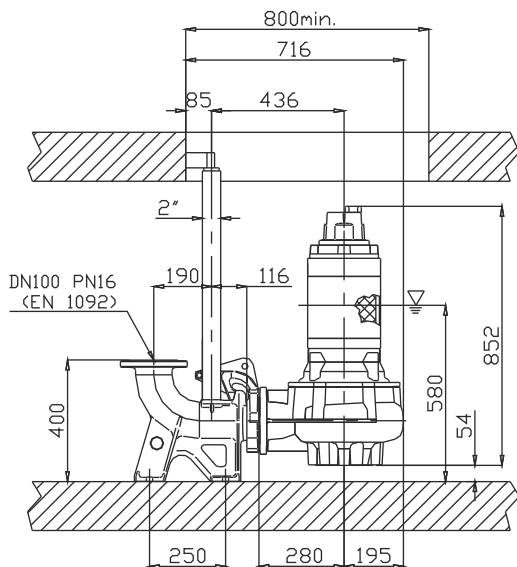
▽ LIVELLO MINIMO DI SOMMERSIBILITÀ
 MINIMUM SUBMERSIBLE LEVEL
 NIVEAU MINIMUM D'IMMERSION
 MINDESTWASSERSTAND
 NIVEL SUMERGIBLE MÍNIMO
 МИНИМАЛЬНАЯ ГЛУБИНА ПОГРУЖЕНИЯ



Versione disponibile con mantello di raffreddamento - Type available also with cooling jacket
 Version disponible avec chemise de refroidissement - Ausführung auch mit Kühlmantel lieferbar
 Disponible también con camisa de refrigeración - Вариант доступен с рубашкой охлаждения

 Ghisa EN-GJL-250
 Fonte EN-GJL-250
 Hierro fundido EN-GJL-250

 Cast Iron EN-GJL-250
 Grauguss EN-GJL-250
 Чугун EN-GJL-250



**Curva caratteristica - Performance curve - Courbe caractéristique
Kennlinie - Curva característica - Характеристическая кривая**

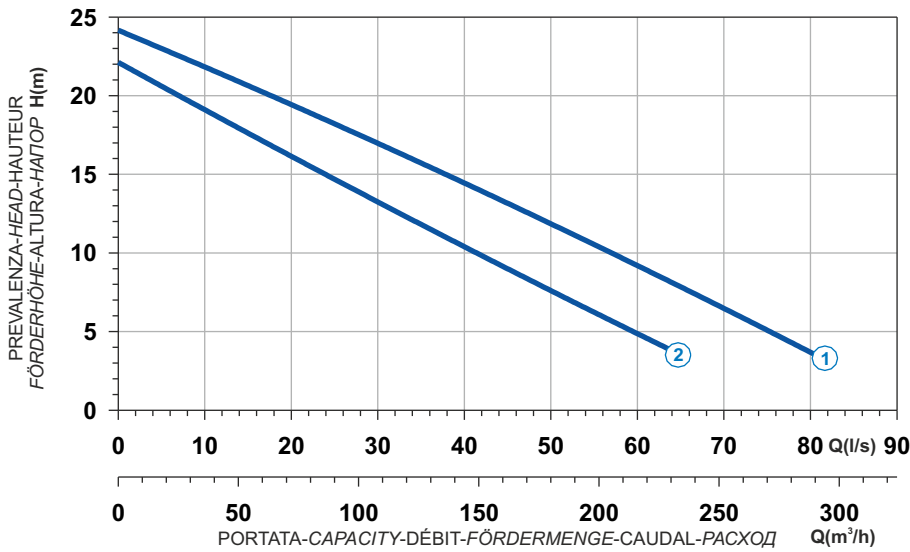

Curve N°	Code	Type	MOTOR			ATEX code 
			Rated power P2 (kW)	Rated current I (A)	Starting current Is (A)	
1	7009232	G413R1M1-P90AA2	11,6	21,6	127,4	7007489
2	7009431	G413R1M2-P90AA2	10	19	112	7007490

Power supply	3ph 400/690V 50Hz
R.P.M.	1436
Free passage (mm)	90
Discharge (mm)	DN 100
Max Weight (Kg)	204

Dimensioni - Dimensions - Dimensions - Abmessungen - Dimensiones - Габариты (mm)

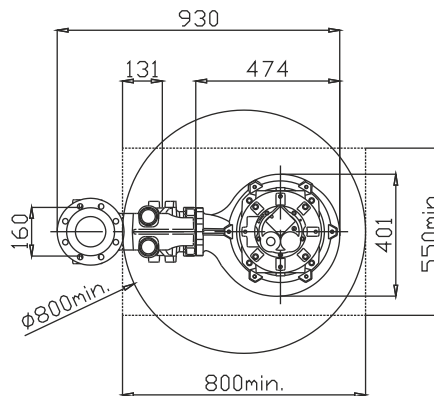
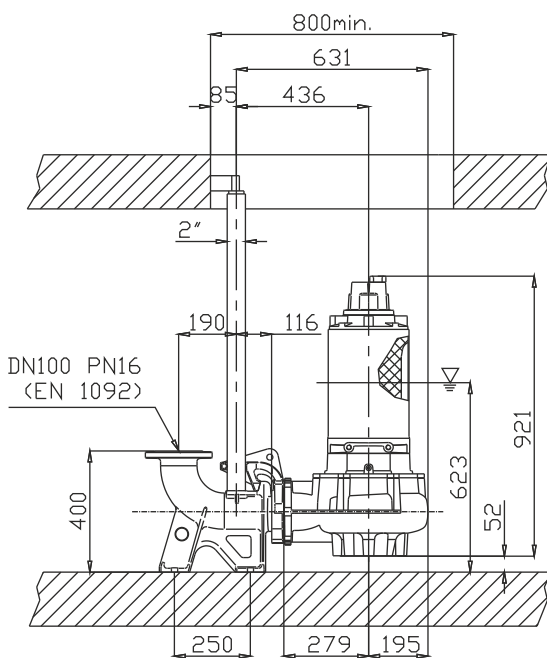

▽ LIVELLO MINIMO DI SOMMERGIBILITÀ
 MINIMUM SUBMERSIBLE LEVEL
 NIVEAU MINIMUM D'IMMERSION
 MINDESTWASSERSTAND
 NIVEL SUMERGIBLE MÍNIMO
 МИНИМАЛЬНАЯ ГЛУБИНА ПОГРУЖЕНИЯ

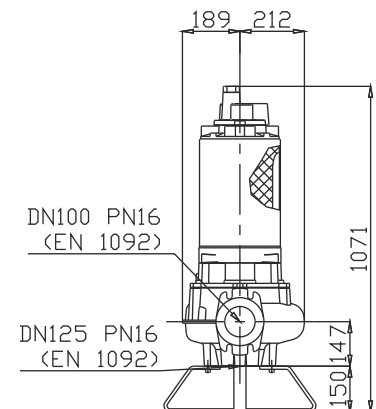

Versione disponibile con mantello di raffreddamento - Type available also with cooling jacket
 Version disponible avec chemise de refroidissement - Ausführung auch mit Kühlmantel lieferbar
 Disponible también con camisa de refrigeración - Вариант доступен с рубашкой охлаждения



- Ghisa EN-GJL-250
- Fonte EN-GJL-250
- Hierro fundido EN-GJL-250

- Cast Iron EN-GJL-250
- Grauguss EN-GJL-250
- Чугун EN-GJL-250

**Curva caratteristica - Performance curve - Courbe caractéristique
Kennlinie - Curva característica - Характеристическая кривая**

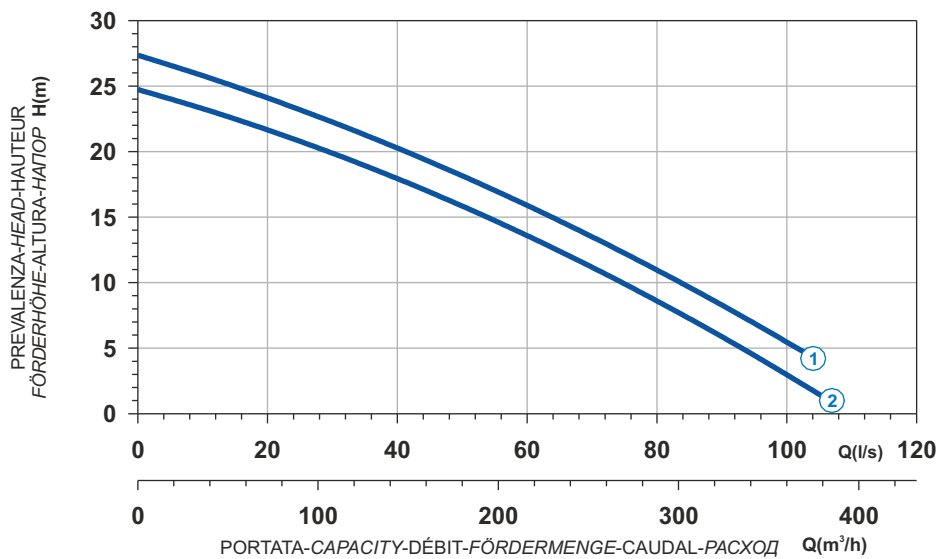

Power supply	3ph 400/690V 50Hz
R.P.M.	1450
Free passage (mm)	100
Discharge (mm)	DN 150
Max Weight (Kg)	376

Curve N°	Code	Type	MOTOR			ATEX code
			Rated power P2 (kW)	Rated current I (A)	Starting current Is (A)	
1	7009710	G416R1M1-S100AA2	17,8	33,3	196	7005835
2	7009937	G416R1M2-S100AA2	15	27,8	164	7006053

Dimensioni - Dimensions - Dimensions - Abmessungen - Dimensiones - Габариты (mm)

▽ LIVELLO MINIMO DI SOMMERSIBILITÀ
MINIMUM SUBMERSIBLE LEVEL
NIVEAU MINIMUM D'IMMERSION
MINDESTWASSERSTAND
NIVEL SUMERGIBLE MÍNIMO
МИНИМАЛЬНАЯ ГЛУБИНА ПОГРУЖЕНИЯ

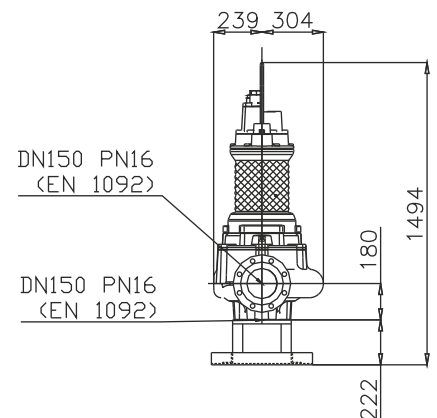
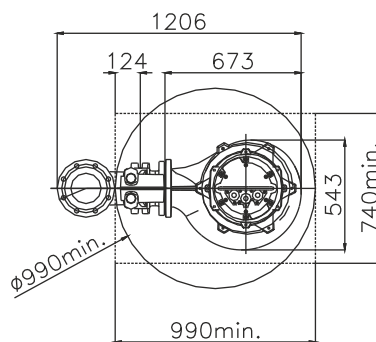
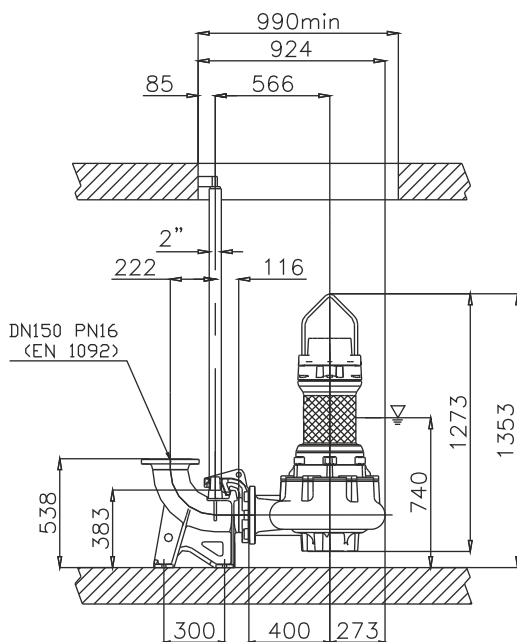

Versione disponibile con mantello di raffreddamento - Type available also with cooling jacket
Version disponible avec chemise de refroidissement - Ausführung auch mit Kühlmantel lieferbar
Disponible también con camisa de refrigeración - Вариант доступен с рубашкой охлаждения

Installazione a secco
Dry pit installation
Installation fixe en chambre sèche
Trockenaufstellung
Instalación fija en cámara aislada
Сухая установка

G411R1M1-P78AA2

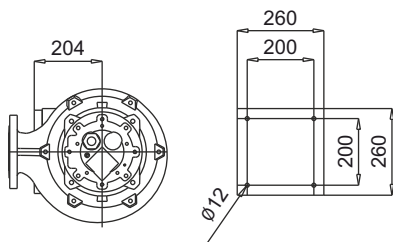
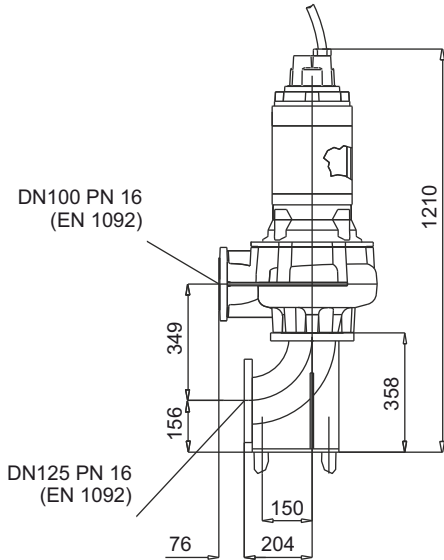

G413R1M1-P90AA2

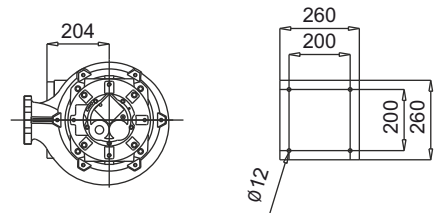
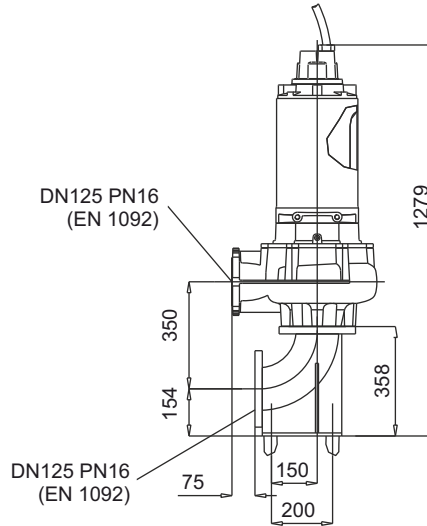

G416R1M1-S100AA2

