

## 40A, 600V IGBT

### DESCRIPTION

SGT40N60FD1P7 using Punch Through IGBT technology, offer the optimum performance for induction Heating, UPS, SMPS and PFC application.

### FEATURES

- ◆ 40A, 600V,  $V_{CE(sat)} = 1.8V @ I_C = 40A$
- ◆ Low conduction loss
- ◆ Fast switching
- ◆ High input impedance

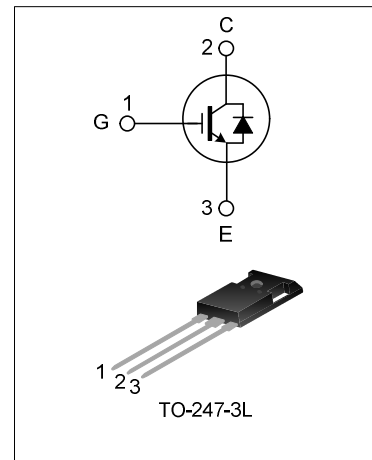

### NOMENCLATURE

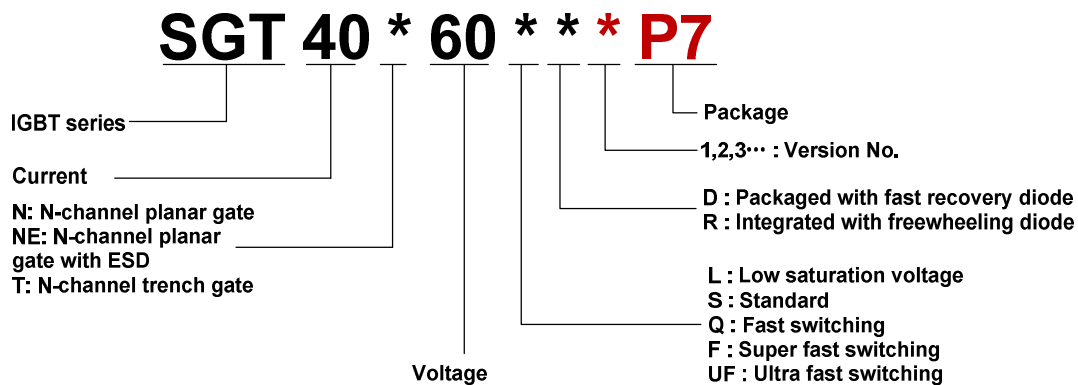

### ORDERING INFORMATION

Part No.	Package	Marking	Material	Packing
SGT40N60FD1P7	TO-247-3L	40N60FD1	Halogen free	Tube

### ABSOLUTE MAXIMUM RATINGS ( $T_C = 25^\circ$ , unless otherwise noted)

Characteristics	Symbol	Ratings	Units
Collector to Emitter Voltage	$V_{CE}$	600	V
Gate to Emitter Voltage	$V_{GE}$	$\pm 20$	V
Collector Current	$I_C$	$T_C = 25^\circ C$	80
		$T_C = 100^\circ C$	40
Pulsed Collector Current	$I_{CM}$	120	A
Maximum Power Dissipation ( $T_C = 25^\circ C$ ) -Reduction per degree Celsius above $25^\circ C$	$P_D$	290	W
		2.32	W/ $^\circ C$
Operating Junction Temperature	$T_J$	-55~+150	$^\circ C$
Storage Temperature Range	$T_{stg}$	-55~+150	$^\circ C$

## THERMAL CHARACTERISTICS

Characteristics	Symbol	Ratings	Units
Thermal Resistance, Junction to Case (IGBT)	$R_{\theta JC}$	0.52	°C/W
Thermal Resistance, Junction to Case (FRD)	$R_{\theta JC}$	1.9	°C/W
Thermal Resistance, Junction to Ambient	$R_{\theta JA}$	40	°C/W

## ELECTRICAL CHARACTERISTICS OF IGBT ( $T_C = 25^\circ\text{C}$ unless otherwise noted)

Characteristics	Symbol	Test conditions	Min.	Typ.	Max.	Units
Collector to Emitter Breakdown Voltage	$BV_{CE}$	$V_{GE}=0V, I_C=100\mu A$	600	--	--	V
C-E Leakage Current	$I_{CES}$	$V_{CE}=600V, V_{GE}=0V$	--	--	200	$\mu A$
G-E Leakage Current	$I_{GES}$	$V_{GE}=20V, V_{CE}=0V$	--	--	$\pm 500$	nA
Gate Threshold Voltage	$V_{GE(th)}$	$I_C=250\mu A, V_{CE}=V_{GE}$	4.0	5.0	6.5	V
Collector to Emitter Saturation Voltage	$V_{CE(sat)}$	$I_C=40A, V_{GE}=15V$	--	1.8	2.7	V
		$I_C=40A, V_{GE}=15V$ $T_C=125^\circ\text{C}$	--	2.5	--	V
Input Capacitance	$C_{ies}$	$V_{CE}=30V$	--	1850	--	pF
Output Capacitance	$C_{oes}$	$V_{GE}=0V$	--	190	--	
Reverse Transfer Capacitance	$C_{res}$	$f=1\text{MHz}$	--	50	--	
Turn-On Delay Time	$T_{d(on)}$	$V_{CE}=400V$ $I_C=40A$ $R_g=10\Omega$	--	16	--	ns
Rise Time	$T_r$		--	88	--	
Turn-Off Delay Time	$T_{d(off)}$		--	110	--	
Fall Time	$T_f$		--	96	--	
Turn-On Switching Loss	$E_{on}$	Inductive Load, $V_{GE}=15V$	--	1.8	--	mJ
Turn-Off Switching Loss	$E_{off}$		--	0.8	--	
Total Switching Loss	$E_{st}$		--	2.6	--	
Total Gate Charge	$Q_g$	$V_{CE} = 300V, I_C=40A,$ $V_{GE} = 15V$	--	100	--	nC
Gate to Emitter Charge	$Q_{ge}$		--	11	--	
Gate to Collector Charge	$Q_{gc}$		--	52	--	

## ELECTRICAL CHARACTERISTICS OF FRD ( $T_C = 25^\circ\text{C}$ unless otherwise noted)

Characteristics	Symbol	Test conditions	Min.	Typ.	Max.	Units
Diode Forward Voltage	$V_{FM}$	$I_F = 20A, T_C=25^\circ\text{C}$	--	1.9	2.6	V
		$I_F = 20A, T_C=125^\circ\text{C}$	--	1.5	--	
Diode Reverse Recovery Time	$T_{rr}$	$I_{ES}=20A, dI_{ES}/dt=200A/\mu s$	--	32	--	ns
Diode Reverse Recovery Charge	$Q_{rr}$	$I_{ES}=20A, dI_{ES}/dt=200A/\mu s$	--	74	--	nC

**TYPICAL CHARACTERISTIC CURVE**

Figure 1. Typical output characteristics

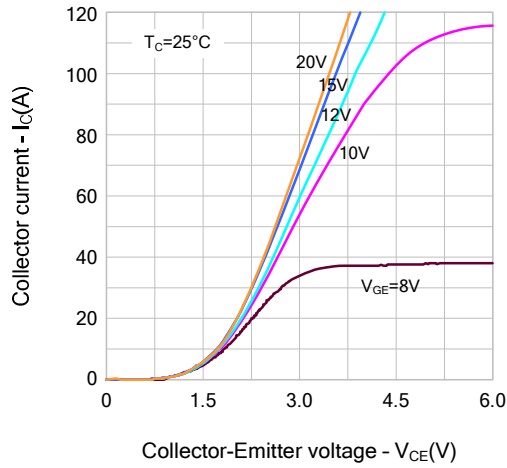

Figure 2. Typical output characteristics

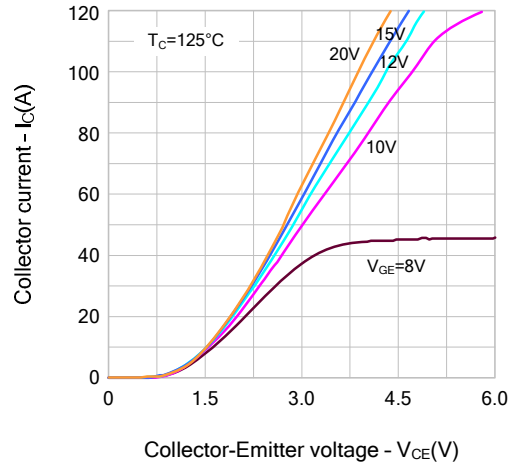

Figure 3. Typical saturation voltage characteristics

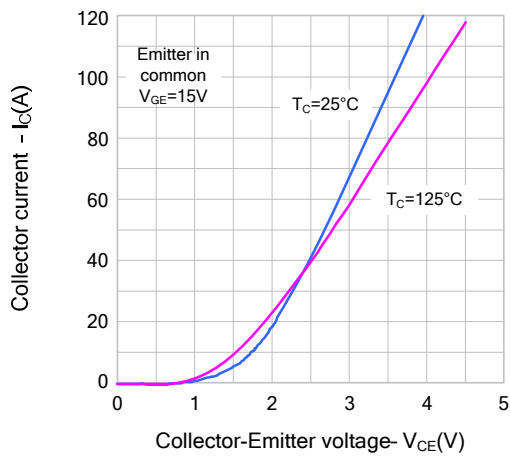

Figure 4. Transmission characteristic

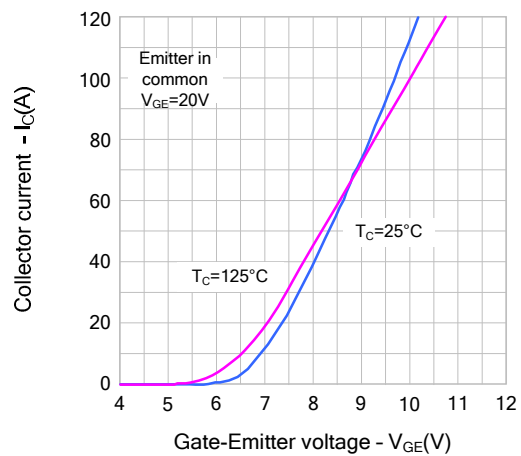

Figure 5. Saturation voltage vs. Vge

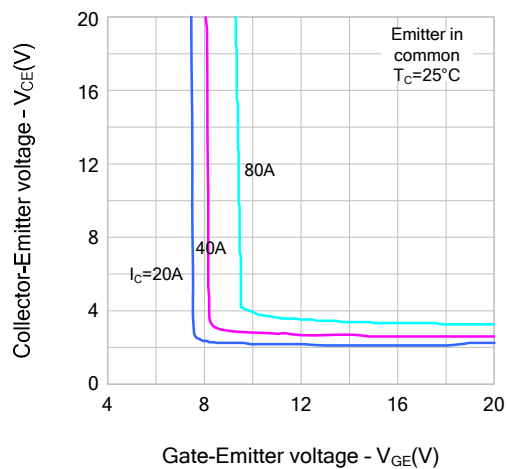
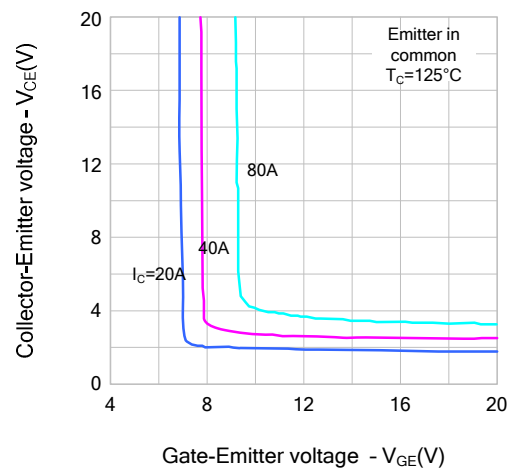

Figure 6. Saturation voltage vs. Vge



**TYPICAL CHARACTERISTIC CURVE (continued)**

Figure 7. Capacitance characteristic

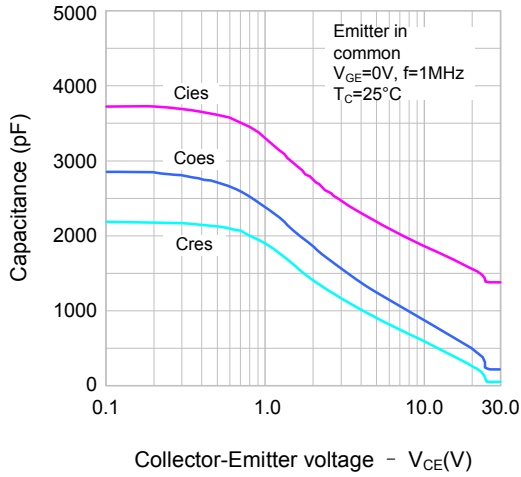

Figure 8. Gate charge characteristic

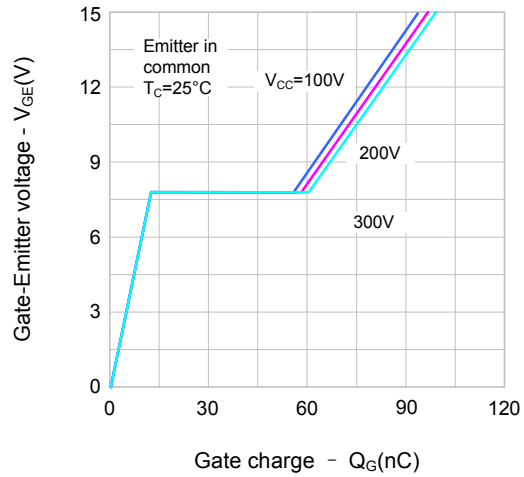

Figure 9. Turn-on characteristic vs. Gate resistance

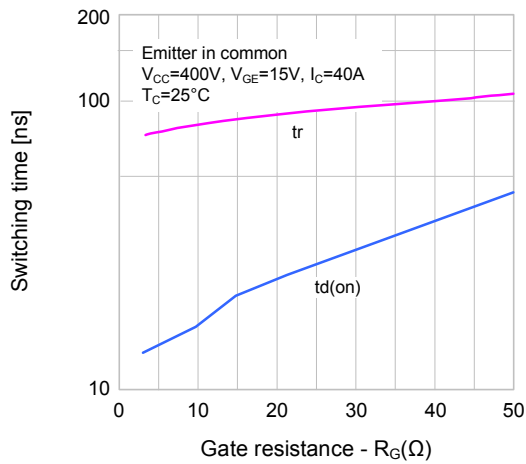

Figure 10. Turn-off characteristic vs. Gate resistance

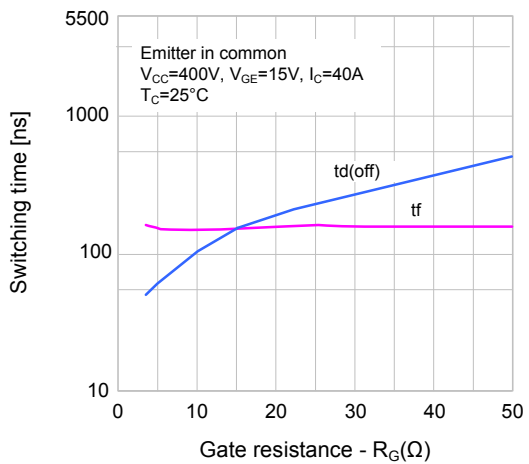

Figure 11. Switching loss vs. Gate resistance

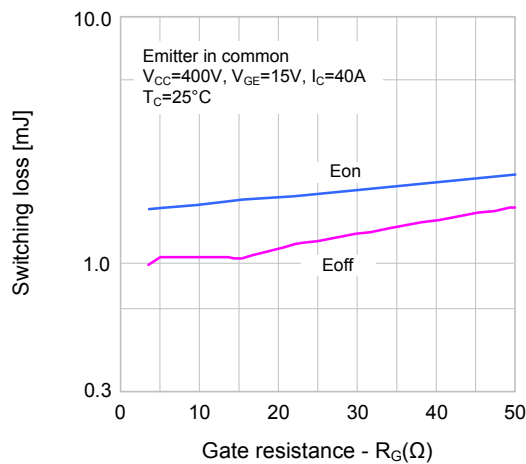
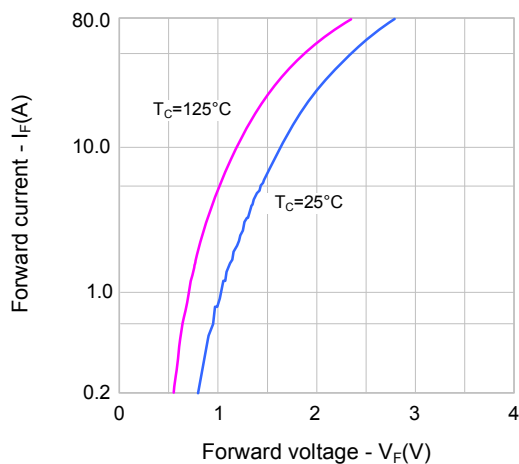
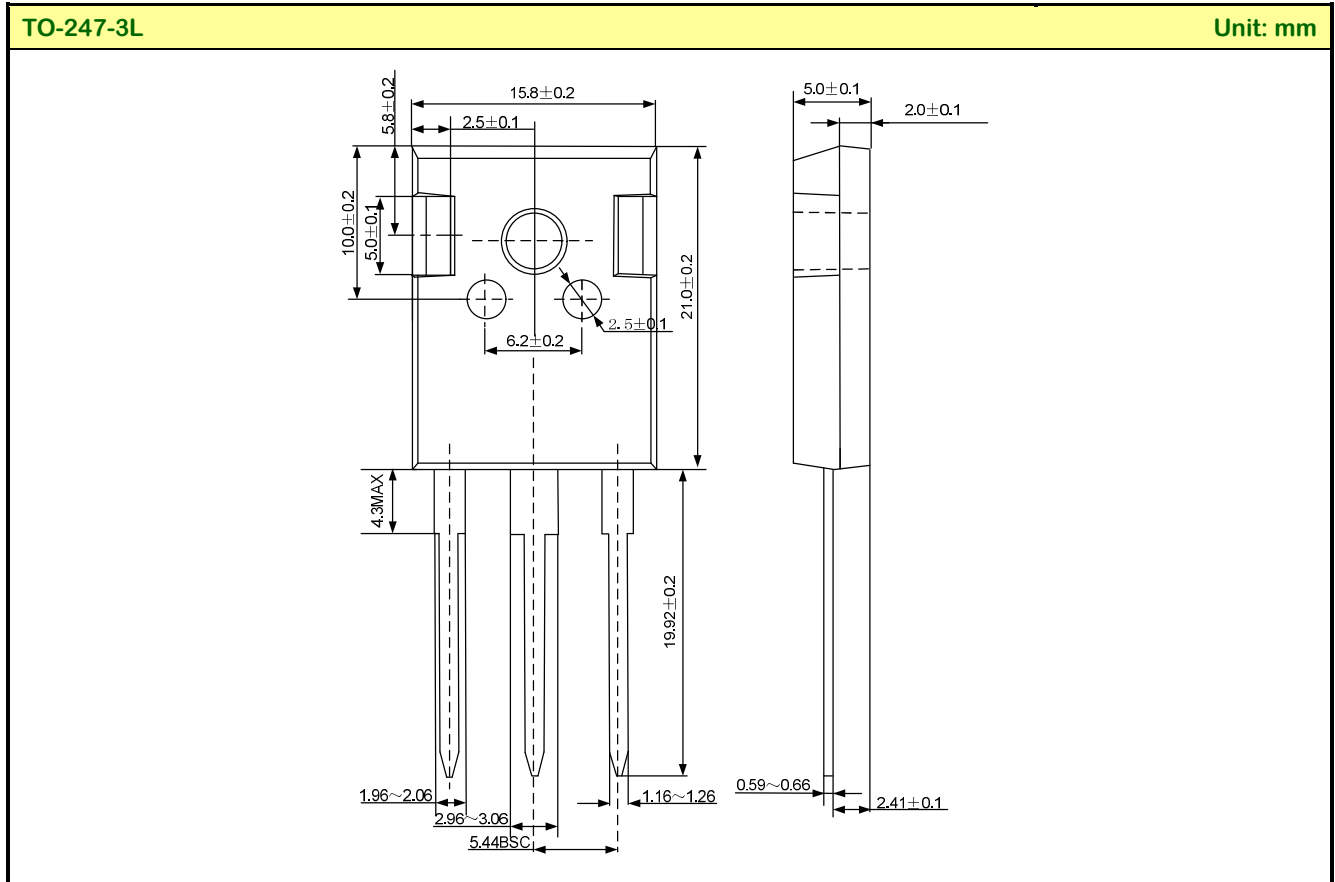

Figure 12. Forward characteristic



**PACKAGE OUTLINE**



**Disclaimer :**

- Silan reserves the right to make changes to the information herein for the improvement of the design and performance without further notice! Customers should obtain the latest relevant information before placing orders and should verify that such information is complete and current.
- All semiconductor products malfunction or fail with some probability under special conditions. When using Silan products in system design or complete machine manufacturing, it is the responsibility of the buyer to comply with the safety standards strictly and take essential measures to avoid situations in which a malfunction or failure of such Silan products could cause loss of body injury or damage to property.
- Silan will supply the best possible product for customers!

---

Part No.:	SGT40N60FD1P7	Document Type:	Datasheet
Copyright:	HANGZHOU SILAN MICROELECTRONICS CO.,LTD	Website:	<a href="http://www.silan.com.cn">http://www.silan.com.cn</a>

---

Rev.:	1.0	Author:	Yin Zi
-------	-----	---------	--------

Revision History:

1. First release
-