

TECHNICAL DATA	
VOLTAGE	12 V
POWER	1.6 KW
SPEED AT 6NM	2850 RPM
ROTATION	CCW
WORKING MODE	S2 = 2MIN S3 = 8%ED
PROTECTION GRADE	IP 54
INSULATION CLASS	F
MASS	6.9 KG
EXTERIOR	ZINC SILVER

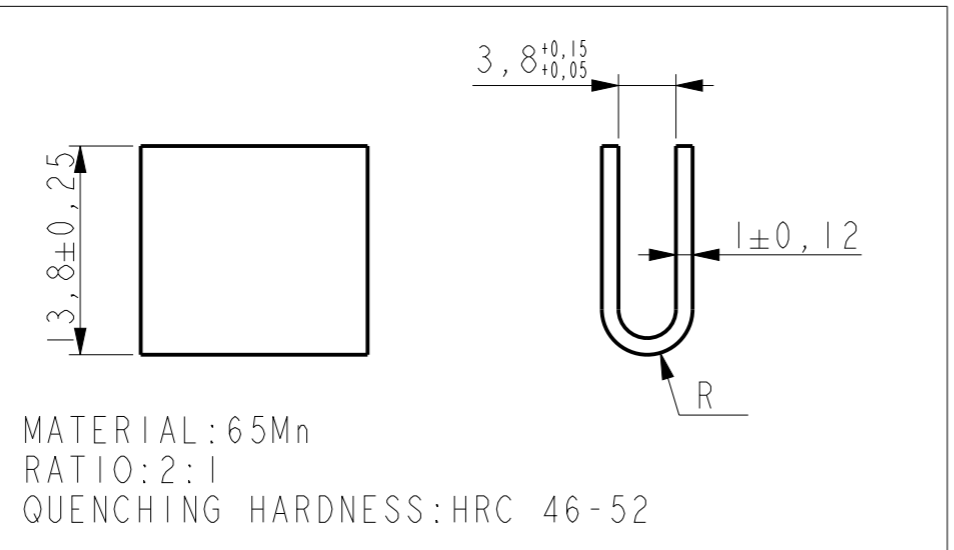

- NOTES:
 1. END OF SHAFT HARDENED TO HRC 46-52
 2. MOTOR FRAME AND ALUMINIUM END HEAD
 3. ▲ MARKED AS THE KEY SIZE

