

**VICTOR**  
AN ESAB BRAND

**GAS**  
EQUIPMENT



## CONTENTS



### GAS OUTFITS

Journeyman® EDGE 2.0.....	2-9
Contender® EDGE 2.0.....	2-9
Journeyman® II EDGE 2.0.....	2-10
Performer® EDGE 2.0.....	2-10
Journeyman® 450.....	2-11
Journeyman® 350.....	2-11
Medalist® 350 Classic.....	2-12
Medalist® 250 Classic.....	2-12
Journeyman® Select EDGE 2.0.....	2-13
Cutter™ Select ST 900FC EDGE 2.0.....	2-14
Cutter™ Select ST 2600FC EDGE 2.0.....	2-14
G150 Portable Tote.....	2-15
Fire-Stick Torch Kit.....	2-16
Powder Spray Torch Kit.....	2-16



### GAS CONTROL

Model Numbering Explanation.....	2-17
How to Read the Flow Data Charts.....	2-18
Pressure Drop Reference Charts.....	2-19
Regulator Selection Guide - By Gas Service.....	2-20
EDGE Series Color Coding by Gas Type.....	2-21
Single Stage Regulators Details.....	2-27
Two Stage Regulators Details.....	2-27
EDGE™ Series Details.....	2-28
EDGE 2.0 Series Regulators Details.....	2-28
ESS42 EDGE 2.0.....	2-29
ESS32 EDGE 2.0.....	2-29
SR 450.....	2-30
SR 350.....	2-31
SR 250.....	2-31
G350.....	2-32
G250.....	2-32
GF250.....	2-33
G150.....	2-33
ESS7.....	2-34
EDGE Adjusting Lock.....	2-34
VTS 700.....	2-35
VTS 250.....	2-35
D1G Pilot-Domeload.....	2-36
ETS4 Series.....	2-37
EHP Series.....	2-38
GT350.....	2-38
SR 4.....	2-39
Mainifold Regulator.....	2-40
ELC4.....	2-41
ESL4.....	2-41
EST4.....	2-42
L 700.....	2-42
SLR 150.....	2-43

ESS32-PFH-800.....	2-44
SR 310/311/312.....	2-44
Flowmeter.....	2-45
HRF 2400 PRO.....	2-46
DFM 150.....	2-46
HSR & HVTS.....	2-47
GRF 400.....	2-48
TPR 250 Purging Regulator.....	2-48
MECO High Pressure.....	2-48



### HANDLE & CUTTING ATTACHMENTS

300 Series HD 310C Torch Handle.....	2-50
300 Series WH 315FC+ Torch Handle.....	2-50
100 Series 100FC Torch Handle.....	2-50
J Series - J-28 & J-40 Torch Handles.....	2-51
CA 2460+ Cutting Attachment.....	2-51
CA 1350 Cutting Attachment.....	2-51
CA 1260 Cutting Attachment.....	2-52
WH370 / WH270 Torch Handle.....	2-52
CA 370-V / CA 270-V Cutting Attachments.....	2-52
400 Series WH 411C Torch Handle.....	2-52
CA 411-1 Cutting Attachment.....	2-52
CA 411-3 Cutting Attachment.....	2-52



### NOZZLES

Type 55/55-1 Multi-Flame Heating Nozzles.....	2-54
Type 55 Components.....	2-54
MFN/MFN-1 Heating Nozzles.....	2-55
MFA/MFA-1 Heating Nozzles.....	2-55
Series 1 Heating Tips.....	2-56
CHT Adaptor.....	2-56
Welding Nozzles.....	2-56
Elbow Tips.....	2-57
UM Series Universal Mixers.....	2-57
RTE Series Replaceable Tip Ends.....	2-57
RTEN Series.....	2-57
FE Series Flexible Elbow.....	2-58
UN Series Universal Nozzle.....	2-58
DFE Series Dual Flexible Elbows.....	2-58
Replaceable Tip Ends.....	2-58



### GAS TORCHES

Victor "Universal Torches".....	2-59
ST 2600FC Series.....	2-60
ST 1000FC Series.....	2-60
ST 900FC Series.....	2-61
ST 400C Series.....	2-61
ST 300FC Series.....	2-61
Bulldog™ – HC 1100C.....	2-62
HC 1200C Series.....	2-63
HC 1500C.....	2-64



### CUTTING TIPS

Tip Nut.....	2-69
Series 1 – Acetylene Cutting Tips.....	2-70
Victor Series 1 Type 101.....	2-71
G-Series Series 1 Type 101.....	2-71
Victor Series 1 Type 101 30°.....	2-72
Victor Series 1 Type 101-L.....	2-72
Victor Series 1 Type 108.....	2-72
G-Series Series 1 Type 108.....	2-72
Victor Series 1 Type 112.....	2-73
Victor Series 1 Type 118 Round).....	2-73
G-Series Series 1 Type 118 (Round).....	2-73
Victor Series 1 Type 118 (Sides Cutaway).....	2-73
G-Series Series 1 Type 118 (Sides Cutaway).....	2-73
Series 1 – Propylene Cutting Tips.....	2-74
Victor Series 1 Type GPP.....	2-75
G-Series Series 1 Type GPP.....	2-75
G-Series Series 1 Type GPP-P (Plated).....	2-76
Victor Series 1 Type HPP.....	2-76
G-Series Series 1 Type HPP.....	2-76
Victor Series 1 Type MTHP.....	2-77
G-Series Series 1 Type MTHP.....	2-77
Victor Series 1 Type 303MP.....	2-78
G-Series Series 1 Type 303MP.....	2-78
Victor Series 1 Type BTMP.....	2-78
Victor Series 1 Type GTB.....	2-79
Victor Series 1 Type 318MP.....	2-79
G-Series Series 1 Type 318MP.....	2-79
Series 1 – LP Cutting Tips.....	2-80
Victor Series 1 Type 200.....	2-81
Victor Series 1 Type 207.....	2-81
Victor Series 1 Type 244.....	2-81
Victor Series 1 Type MCN.....	2-81
Victor Series 1 Type GPN.....	2-82
G-Series Series 1 Type GPN.....	2-82
G-Series Series 1 Type GPN (Plated).....	2-83
Victor Series 1 Type MTHN.....	2-83
G-Series Series 1 Type MTHN.....	2-84
Victor Series 1 Type HPN.....	2-84



### SAFETY ACCESSORIES

Flashback Arrestors and Check Valves.....	2-89
FlameBuster™ High Flow.....	2-90
FlameBuster™.....	2-90
FlameBuster™ Plus.....	2-91
Flashback Arrestors.....	2-91
Reverse Flow Check Valves.....	2-91
Built-in Flash Arrestor.....	2-91
Flashback Arrestor with Kwik-Connect.....	
Coupling Components FBP-1.....	2-91
Vanguard™ Flashback Arrestor.....	2-91
Kwik-Connect.....	2-91



### PORTABLE CUTTING MACHINES

VCM 200/201 Cutting Machines.....	2-92
Torch Holder Adapter & Accessories.....	2-92



### ACCESSORIES

Model BHA 2.....	2-93
Model 591.....	2-93
Model 497 Roller Guide.....	2-93
Circle Cutting Attachment.....	2-93
Test Gauges.....	2-93
Gear Racks.....	2-93
Replacement Hoses.....	2-94
L1-Single Flint Striker.....	2-94
Triple Flint Striker.....	2-94
Flint Refills.....	2-94
TK Tank Key.....	2-94
Tip Cleaner.....	2-94

### REFERENCE

Withdrawing Acetylene from Cylinders.....	2-95
Gas Equipment Product Compliance Standards.....	2-95

# EVOLUTION. INNOVATION. INSPIRATION.



**1913**  
The history of Victor begins in 1913 in San Francisco. The founder of Victor, Mr. L.W. Stettner suffered a serious injury. A welder by trade, Stettner lost an eye during a welding accident, and following recovery, he was determined to design safer welding equipment and accessories – the birth of the Victor Torch.

**1941–1945**  
Victor torches are integral to the war effort in World War II.



**1918**  
The Victor handle was the first to feature a tube within a tube design to create a smaller diameter handle.

Victor was the first to design and invent the cutting attachment which included spiral mixers.

**1940s**  
The SR 40 Oxygen Safety Regulator was a single stage reduction regulator. It featured a simplified seat mechanism which eliminated the ball housing.



**1937**  
Mayor Angelo Rossi uses a Victor cutting torch to cut the chain opening the Golden Gate Bridge.



**1980**  
Victor began to manufacture the 315 welding handle with built-in check valves.

**1995**  
Victor patents built-in flashback arrestors into their torches for added operator safety.

**2013**  
Victor 400 series cutting torches with ergonomic handle and G Series regulators released.

**1966**  
Victor Equipment Company moved to Denton, Texas.



**2009**  
Victor introduced the EDGE™ regulator changing the landscape of gas regulation.



**2012**  
The Golden Gate Bridge has its 75th Anniversary, Governor Schwarzenegger uses a Victor torch to recreate the original chain cutting ceremony.



Victor manufacturing team worked overtime to produce over 5,000 pieces of equipment including special 15 and 20 foot length cutting torches to help with 9/11 clean-up efforts.

**2014**  
Victor becomes An ESAB Brand





# INDUSTRY BEST WARRANTY

on Top Victor Products

ESAB brings you the safest quality products available in the market **NOW** with the industry's best warranty.

See below for details.

## Warranty Details

Warranty periods for our most popular Victor regulators, torches, and handles have been extended, including a LIFETIME Warranty on all EDGE Series 2.0 regulators.

PRODUCT	WARRANTY PERIOD							
	LIFE TIME	10 YEARS	7 YEARS	3 YEARS	2 YEARS	1 YEAR	90 DAYS	+LABOR
EDGE Series Regulators	✓							
Legacy SR Series Regulators		✓						
Professional Victor Torches and Handles		✓						
All "G" Series Regulators			✓					
Medalist Line of Torches and Handles			✓					
TurboTorch Products				✓				
HP&I Brass Regulators/Manifolds, Oxygen Conservers, All Other Victor Medical Products					✓			
Steel Cylinders, Cutting Machine Motor (i.e. VCM200)						✓		
HP&I Stainless Regulators/Manifolds (non-corrosive gas), Parts in Rental Applications						✓		
HP&I Corrosive Gas Regulators/Manifolds							✓	

## GENERAL WARRANTY DETAILS

### ESAB products are backed by some of the best warranties around.

At ESAB, customer satisfaction is our number one priority. Your ESAB product is backed by one of the most comprehensive warranty programs in the industry. You can feel confident that with the purchase of an ESAB product, you have selected the best quality, supported by the best customer service available. Our ESAB Warranty will keep you covered.

### Product warranty periods.

Properly stored ESAB filler metals are warranted to be fully serviceable and free from any defects in materials or workmanship for one full year after the date of shipment from ESAB. The warranty period for ESAB welding equipment starts on the invoice date of purchase by the original end-user, or from the date of manufacture if the original invoice cannot be produced.

### For Welding Equipment/Automated Cutting Systems:

Phone 1-800-426-1888  
Fax 800-535-0557

### What's covered by the ESAB Warranty?

The ESAB Warranty covers every piece of ESAB welding equipment, every filler metal, every gas apparatus, and every plasma machine – every product that ESAB sells in the US, Canada, and Mexico, excluding the following: mechanized cutting machines, scarfing machines, automation equipment, spare parts, consumables, special orders, re-manufactured items, minimum run products, and freight damage.

### Filing an ESAB Warranty claim.

For all warranty claims, Buyer should contact ESAB with all relevant details such as ESAB part number, manufacturing date code, heat and control numbers, serial number, complete description of the difficulty encountered, length of time in service, the conditions under which the Goods failed, and original purchase price paid.

### For Filler Metals:

Please contact your ESAB Sales Account Manager. If you are an end user, please contact your local Authorized ESAB distributor for assistance with warranty claims.

ESAB will determine whether to have the Goods returned for inspection and repair or handled in some other manner (for example: shipping replacement Goods "no charge" or issuing credit). Credit for Welding Equipment/Automated Cutting Systems may be subject to a depreciation charge based on length of time the Goods were in service. Written approval in the form of a Return Authorization form ("RA") will be issued if Buyer is to return Goods for repair or replacement. **UNDER NO CIRCUMSTANCES ARE ANY GOODS TO BE RETURNED WITHOUT PRIOR WRITTEN AUTHORIZATION FROM ESAB.** A copy of the RA must accompany the return shipment of the Goods to ESAB, and the Goods must be received within 30 days of issuance of the RA. Any RA remaining open after 30 days will be cancelled, and the Buyer will be billed for any "no charge" replacement Goods supplied. Any Goods subsequently returned against a cancelled RA will be returned to the Buyer freight collect.

**If a returned Good is determined to have failed for reasons other than defects in materials or workmanship within the scope of the warranty policy or if the applicable warranty has expired, Buyer will be contacted for disposition. If such a Good is to be returned to Buyer, freight charges will be borne by Buyer, and Buyer also will be billed for any "no charge" replacement Goods supplied during the investigation of the complaint.**

# ONLY ONE BRAND CAN LEAD YOU TO VICTORY.





# JOURNEYMAN® EDGE 2.0

Cutting, Heating and Welding Outfit

- Cuts up to 8 in. (203.2 mm), welds up to 3 in. (76.2 mm) with accessories
- Up to 1,118,000 BTUs/hour heating
- ESS42 Series regulators
- WH 315FC+ torch handle with built-in flash arrestors and check valves
- CA 2460+ cutting attachment
- Also includes cutting tip, tip cleaner, heating nozzle, striker, goggles, hose, welding nozzles and two EDGE 2.0 regulators (Oxygen & Fuel Gas)



Ordering Information											
Part No.	Description	Torch Handle	Cutting Attachment	Welding Nozzle	Heating Nozzle	Cutting Tip	Oxygen Regulator	Fuel Gas Regulator	Hose	Accessories	Gas Service
0384-2100	Journeyman EDGE 2.0 540/300, 90° Plus Outfit	WH315FC+	CA 2460+ 90° Head	1-W 3-W 5-W	8-MFA	1-1-101	ESS42-150-540	ESS42-15-300	1/4" x 20' Grade "T"	Goggles, Striker, Tip Cleaner	Acetylene
0384-2101	Journeyman EDGE 2.0 540/510, 90° Plus Outfit	WH315FC+	CA 2460+ 90° Head	1-W 3-W 5-W	8-MFA	1-1-101	ESS42-150-540	ESS42-15-510			Acetylene

# JOURNEYMAN® II EDGE 2.0

Cutting and Welding Outfit

- Cuts up to 8 in. (203.2 mm), welds up to 3 in. (76.2 mm) with accessories
- ESS42 Series regulators
- WH 315FC+ torch handle with built-in flash arrestors and check valves
- CA 2460+ cutting attachment
- Also includes cutting tip, tip cleaner, heating nozzle, striker, goggles, hose, welding nozzles and two EDGE 2.0 regulators (Oxygen & Fuel Gas)



Ordering Information											
Part No.	Description	Torch Handle	Cutting Attachment	Welding Nozzle	Heating Nozzle	Cutting Tip	Oxygen Regulator	Fuel Gas Regulator	Hose	Accessories	Gas Service
0384-2110	Journeyman II EDGE 2.0 540/300, 90° Plus Outfit	WH315FC+	CA 2460+ 90° Head	2-W	-	1-1-101	ESS42-150-540	ESS42-15-300	1/4" x 20' Grade "T"	Goggles, Striker, Tip Cleaner	Acetylene
0384-2111	Journeyman II EDGE 2.0 540/510, 90° Plus Outfit	WH315FC+ 0382-0093	CA 2460+ 90° Head	2-W	-	1-1-101	ESS42-150-540	ESS42-15-510			Acetylene
0384-2112	Journeyman II AF EDGE 2.0 540/510LP, 90° Plus Outfit (propane)	WH315FC+	CA 2460+ 90° Head	-	8 Type 55	1-GPN	ESS42-150-540	ESS42-60-510LP			Propane/NG
0384-2113	Journeyman II AF EDGE 2.0 540/510LP, 90° Plus Outfit (propylene)	WH315FC+	CA 2460+ 90° Head	-	8 Type 55	1-GPP	ESS42-150-540	ESS42-60-510LP			Propylene

# CONTENDER® EDGE 2.0

Cutting and Heating Outfit

- Cuts up to 8 in. (203.2 mm) and welds up to 3 in. (76.2 mm) with accessories
- ESS32 Series regulators
- WH 315FC+ torch handle with built-in flash arrestors and check valves
- CA 2460+ cutting attachment
- Also includes cutting tip, tip cleaner, striker, goggles, hose, heating nozzle and two EDGE 2.0 regulators



Ordering Information											
Part No.	Description	Torch Handle	Cutting Attachment	Welding Nozzle	Heating Nozzle	Cutting Tip	Oxygen Regulator	Fuel Gas Regulator	Hose	Accessories	Gas Service
0384-2130	Contender 540/510 EDGE 2.0 Outfit	WH315FC+	CA 2460+ 90° Head	-	6-MFA	1-1-101	ESS32-150-540	ESS32-15-510	1/4" x 20' Grade "T"	Goggles, Striker, Tip Cleaner	Acetylene
0384-2131	Contender 540/300 EDGE 2.0 Outfit	WH315FC+	CA 2460+ 90° Head	-	6-MFA	1-1-101	ESS32-150-540	ESS32-15-300			Acetylene
0384-2132	Contender AF 540/510LP EDGE 2.0 Outfit (propane & propylene tips)	WH315FC+	CA 2460+ 90° Head	-	8 Type 55	1-GPN 1-GPP	ESS32-150-540	ESS32-60-510LP			Propane/NG/Propylene

# PERFORMER® EDGE 2.0

Cutting, Heating and Welding Outfit

- Cuts up to 6 in. (152.4 mm) and welds up to 1/4 in. (6.4 mm) with accessories
- ESS32 Series regulators
- CA1350 cutting attachment
- WH100FC torch handle with built-in flashback arrestors and check valves
- Also includes cutting tip, tip cleaner, striker, goggles, hose, welding nozzle, heating nozzle and two EDGE 2.0 regulators



Ordering Information											
Part No.	Description	Torch Handle	Cutting Attachment	Welding Nozzle	Heating Nozzle	Cutting Tip	Oxygen Regulator	Fuel Gas Regulator	Hose	Accessories	Gas Service
0384-2125	Performer 540/510 EDGE 2.0 Outfit	100FC	CA 1350 90° Head	0-W-1	4-MFA-1	0-3-101	ESS32-150-540	ESS32-15-510	3/16" x 12.5' Grade "T"	Goggles, Striker, Tip Cleaner	Acetylene
0384-2126	Performer 540/300 EDGE 2.0 Outfit	100FC	CA 1350 90° Head	0-W-1	4-MFA-1	0-3-101	ESS32-150-540	ESS32-15-300			Acetylene
0384-2127	Performer AF 540/510LP EDGE 2.0 Outfit (propane & propylene tips)	100FC	CA 1350 90° Head	-	6 TYPE 55-1	0-3-GPN 0-3-GPP	ESS32-150-540	ESS32-60-510LP			Propane/NG/Propylene



# JOURNEYMAN® 450

Heavy Duty Cutting and Welding Outfit

- Cuts up to 8 in. (203.2 mm) with optional tips
- Welds up to 3 in. (76.2 mm) with optional nozzles
- Heavy Duty Construction
- 315FC Torch handle with Flashback Arrestors and Built-in Check Valves
- SR 450 Series Regulators
- CA2460 Cutting Attachment
- Cutting Tips
- Welding Nozzle



Ordering Information											
Part No.	Description	Torch Handle	Cutting Attachment	Welding Nozzle	Heating Nozzle	Cutting Tip	Oxygen Regulator	Fuel Gas Regulator	Hose	Accessories	Gas Service
0384-0807	Journeyman 450 540/510	WH315FC+	CA 2460+ 90° Head	2-W	-	0-1-101 1-1-101 2-1-101	SR450D-540	SR460A-510	-	-	Acetylene
0384-0808	Journeyman 450 540/300	WH315FC+	CA 2460+ 90° Head	2-W	-	0-1-101 1-1-101 2-1-101	SR450D-540	SR460A-300	-	-	Acetylene

# JOURNEYMAN® 350

Medium Duty Cutting and Welding Outfit

- Cuts up to 8 in. (203.2 mm) with optional tips
- Welds up to 3 in. (76.2 mm) with optional nozzles
- Medium Duty Construction
- Torch handle with Built-in Check Valves and Flashback Arrestors
- Series Regulators
- Cutting Attachment
- Cutting Tips
- Welding Nozzle



Ordering Information											
Part No.	Description	Torch Handle	Cutting Attachment	Welding Nozzle	Heating Nozzle	Cutting Tip	Oxygen Regulator	Fuel Gas Regulator	Hose	Accessories	Gas Service
0384-0804	Journeyman 350 540/510	WH315FC+	CA 2460+ 90° Head	-	-	1-1-101	SR350D-540	SR360A-510	-	-	Acetylene
0384-0805	Journeyman 350 540/300	WH315FC+	CA 2460+ 90° Head	-	-	1-1-101	SR350D-540	SR360A-300	-	-	Acetylene

# MEDALIST® 350 CLASSIC

Heavy Duty Cutting and Welding Outfit

- Cuts up to 6 in. (152 mm) with optional tips
- Welds up to 3 in. (76 mm) with optional nozzles
- Heavy Duty Construction
- Torch handle has Built-in Check Valves and Flashback Arrestors
- One Cutting Attachment for all Fuel Gases (with proper tip)
- G350 Regulator features 2.5 in. (63 mm) Gauges (Oxygen & Fuel Gas)



Ordering Information											
Part No.	Description	Torch Handle	Cutting Attachment	Welding Nozzle	Heating Nozzle	Cutting Tip	Oxygen Regulator	Fuel Gas Regulator	Hose	Accessories	Gas Service
0384-2698	Medalist 350 Classic 540/510	WH370FC	CA370 90° Head	1-W	-	1-1-101	G350-150-540	G350-15-510	1/4" x 20' Grade "T"	Goggles, Striker	Acetylene
0384-2699	Medalist 350 Classic 540/3000	WH370FC	CA370 90° Head	1-W	-	1-1-101	G350-150-540	G350-15-300			Acetylene
0384-2710	Medalist 350LP Classic 540/510LP	WH370FC	CA370 90° Head	-	8-MFN	1-GPN	G350-150-540	G350-60-510LP			Propane/NG

# MEDALIST® 250 CLASSIC

Medium Duty Cutting and Welding Outfit

- Cuts up to 5 in. (127.0 mm) with optional tips
- Welds up to 1.25 in. (31.8 mm) with optional nozzles
- Medium Duty Industrial Construction
- Torch handle has Built-in Check Valves and Flashback Arrestors
- One Cutting Attachment for all Fuel Gases (with proper tip)



Ordering Information											
Part No.	Description	Torch Handle	Cutting Attachment	Welding Nozzle	Heating Nozzle	Cutting Tip	Oxygen Regulator	Fuel Gas Regulator	Hose	Accessories	Gas Service
0384-2580	Medalist 250 Classic 540/510	WH270FC	CA270 90° Head	1-W-1	-	1-3-101	G250-150-540	G250-15-510	3/16" x 20' Grade "T"	Goggles, Striker	Acetylene
0384-2581	Medalist 250 Classic 540/300	WH270FC	CA270 90° Head	1-W-1	-	1-3-101	G250-150-540	G250-15-300			Acetylene
0384-2583	Medalist 250LP Classic 540/510LP	WH270FC	CA270 90° Head	-	6-MFN-1	1-3-GPN	G250-150-540	G250-60-510LP			Propane/NG
0384-2584	Medalist 250LP Classic 540/510LP	WH270FC	CA270 90° Head	-	6-MFN-1	1-3-GPP	G250-150-540	G250-60-510LP			Propylene



GAS OUTFITS



# JOURNEYMAN® SELECT EDGE 2.0

Heavy Duty Cutting Outfit

- Cuts up to 8 in. (203.2 mm) with optional tips
- WH 315FC torch handle with built-in flashback arrestors and check valves
- ESS42 Series regulators
- WH 315FC+ torch handle with built-in flash arrestors and check valves
- CA 2460+ cutting attachment



Ordering Information											
Part No.	Description	Torch Handle	Cutting Attachment	Welding Nozzle	Heating Nozzle	Cutting Tip	Oxygen Regulator	Fuel Gas Regulator	Hose	Accessories	Gas Service
0384-2081	Journeyman Select EDGE 2.0 540/510, 90° Plus Outfit	WH315FC+	CA 2460+ 90° Head	-	-	-	ESS42-150-540	ESS42-15-510	-	-	Acetylene
0384-2082	Journeyman Select EDGE 2.0 540/510, 75° Plus Outfit	WH315FC+	CA 2460+ 90° Head	-	-	-	ESS42-150-540	ESS42-15-510	-	-	Acetylene
0384-2083	Journeyman Select EDGE 2.0 540/300, 90° Plus Outfit	WH315FC+	CA 2460+ 90° Head	-	-	-	ESS42-150-540	ESS42-15-300	-	-	Acetylene
0384-2088	Journeyman Select AF EDGE 2.0 540/510LP, 90° Plus Outfit	WH315FC+	CA 2460+ 90° Head	-	-	-	ESS42-150-540	ESS42-60-510LP	-	-	Propane/NG/Propylene

# CUTTER™ SELECT ST 2600FC EDGE 2.0

Heavy Duty Cutting Outfit

- Cuts up to 8 in. (203.2 mm) with accessories
- ST 2600FC cutting torch with built-in flashback arrestors and check valves
- ESS42 Series regulators
- Available with 90° head angle



Ordering Information										
Part No.	Description	Straight Torch	Welding Nozzle	Heating Nozzle	Cutting Tip	Oxygen Regulator	Fuel Gas Regulator	Hose	Accessories	Gas Service
0384-2120	Cutter EDGE 2.0 ST 2600FC 540/510, 90° Outfit	ST 2600FC 21"x 90°	-	-	-	ESS42-150-540	ESS42-15-510	-	-	Acetylene
0384-2121	Cutter EDGE 2.0 ST 2600FC 540/300, 90° Outfit	ST 2600FC 21"x 90°	-	-	-	ESS42-150-540	ESS42-15-300	-	-	Acetylene
0384-2122	Cutter AF EDGE 2.0 ST 2600FC 540/510LP, 90° Outfit	ST 2600FC 21"x 90°	-	-	-	ESS42-150-540	ESS42-60-510LP	-	-	Propane/NG/Propylene

# CUTTER™ SELECT ST 900FC EDGE 2.0

Heavy Duty Cutting Outfit

- Cuts up to 8 in. (203.2 mm) and welding up to 1/4 in. (6.4 mm) with accessories
- ESS32 Series regulators
- ST900FC Straight Cutting Torch with built-in flashback arrestors



Ordering Information											
Part No.	Description	Straight Torch	Welding Nozzle	Heating Nozzle	Cutting Tip	Oxygen Regulator	Fuel Gas Regulator	Hose	Accessories	Gas Service	
0384-2140	Cutter EDGE 2.0 ST 2600FC 540/510, 90° Outfit	ST900FC 21"x 90°	-	-	-	ESS32-150-540	ESS32-15-300	-	-	Acetylene	
0384-2141	Cutter EDGE 2.0 ST 2600FC 540/300, 90° Outfit	ST900FC 21"x 90°	-	-	-	ESS32-150-540	ESS32-15-510	-	-	Acetylene	
0384-2142	Cutter AF EDGE 2.0 ST 2600FC 540/510LP, 90° Outfit	ST900FC 21"x 90°	-	-	-	ESS32-150-540	ESS32-60-510LP	-	-	Propane/NG/Propylene	

MANUAL  
GOUGING



# G150 PORTABLE TOTE

Light Duty Portable Outfit

- Designed with a patented, molded, plastic carrying case
- Ergonomic handle
- Patented balance design with small footprint
- Built-in storage compartments
- Includes G-150 regulators



Ordering Information																
Part No.	Description	Torch Handle	Cutting Att.	Weld Nozzle	Heat Nozzle	Universal Nozzle	Cut Tip	Heat Tip	Quick Disconnect	Oxygen Regulator	Fuel Gas Regulator	Hose	OXY Cyl.	FUEL Cyl.	Accs.	Gas Service
0384-0943	G150-100-CP Tote w/o tanks	100FC	CA1350 90° Head	1-W-1	-	-	0-3-101	-	-	G150-60-540R	G150-15-200R	3/16 x 12.5' GRADE "T" "B" FITTING	-	-	Goggles, Stricker, Cyl. Wrench	Acetylene
0384-0944	G150-100-CPT Tote w/ tanks	100FC	CA1350 90° Head	1-W-1	-	-	0-3-101	-	-	G150-60-540R	G150-15-200R	3/16 x 12.5' GRADE "T" "B" FITTING	OX-20	AC-MC		Acetylene
0384-0945	G150-J-P Tote w/o tanks	SKH-7A	-	SKW0 SKW2	-	-	-	-	-	G150-60-540R 020 "A"	G150-15-200R 021 "A"	3/16 x 12.5' GRADE "T" "A" FITTING	-	-	Goggles, Stricker, Cyl. Wrench	Acetylene
0384-0946	G150-J-PT Tote w/ tanks	SKH-7A	-	SKW0 SKW2	-	-	-	-	-	G150-60-540R 020 "A"	G150-15-200R 021 "A"	3/16 x 12.5' GRADE "T" "A" FITTING	OX-20	AC-MC		Acetylene
0384-0947	G150-J-CP Tote w/o tanks	SKH-7A	SLCA1260 90° Head	SKW0 SKW2	-	-	0-3-101	-	-	G150-60-540R 020 "A"	G150-15-200R 021 "A"	3/16 x 12.5' GRADE "T" "A" FITTING	-	-	Goggles, Stricker, Cyl. Wrench	Acetylene
0384-0948	G150-J-CPT Tote w/ tanks	SKH-7A	SLCA1260 90° Head	SKW0 SKW2	-	-	0-3-101	-	-	G150-60-540R 020 "A"	G150-15-200R 021 "A"	3/16 x 12.5' GRADE "T" "A" FITTING	OX-20	AC-MC		Acetylene
0384-0954	G150-J-AFP Tote w/o tanks	SKH-7A	-	-	-	UN-J	-	0-TEN 2-TEN 3-TEMFN	-	G150-60-540R 020 "A"	MR-5	3/16 x 12.5' GRADE "T" "A" FITTING	-	-	Goggles, Stricker	Alt Fuel
0384-0955	G150-J-AP Tote w/o tanks	J-28	-	2-W-J 4-W-J	PL-8A	-	-	-	160-02P	G150-60-540R 020 "A"	G150-15-200R 021 "A"	3/16 x 12.5' GRADE "T" "A" FITTING	-	-	Goggles, Stricker, Cyl. Wrench	Acetylene
0384-0956	G150-J-APT Tote w/ tanks	J-28	-	2-W-J 4-W-J	PL-8A	-	-	-	160-02P	G150-60-540R 020 "A"	G150-15-200R 021 "A"	3/16 x 12.5' GRADE "T" "A" FITTING	OX-20	AC-MC		Acetylene
0384-0957	G150-J-ACP Tote w/o tanks	J-28	CA1260 90° Head	00-W-J 1-W-J 3-W-J	PL-8A	-	0-3-101	-	160-02P	G150-60-540R 020 "A"	G150-15-200R 021 "A"	3/16 x 12.5' GRADE "T" "A" FITTING	-	-	Goggles, Stricker, Cyl. Wrench	Acetylene
0384-0958	G150-J-ACPT Tote w/ tanks	J-28	CA1260 90° Head	00-W-J 1-W-J 3-W-J	PL-8A	-	0-3-101	-	160-02P	G150-60-540R 020 "A"	G150-15-200R 021 "A"	3/16 x 12.5' GRADE "T" "A" FITTING	OX-20	AC-MC		Acetylene

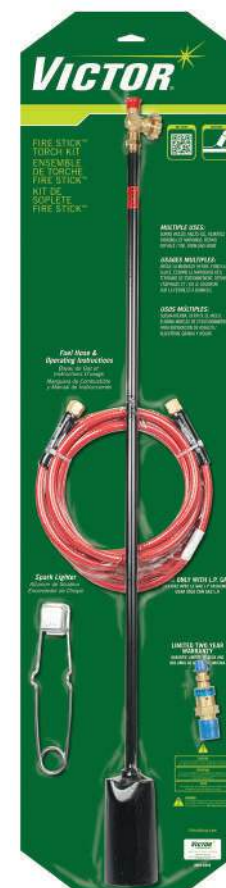

# FIRE-STICK TORCH KIT

Torch Kit

- This heating system can deliver up to 500,000 BTU's avg./hr.
- Two models available – with or without regulator
- For propane – (hose approved for LP)

Ordering Information							
Part No.	Description	Torch Handle	Fuel Gas Regulator	Hose	Accessories	Gas Service	BTU's
0384-1261	HT-500 Torch Kit, Fire-Stick, 500,000 BTU's	HT-500 Heating Torch	-	LPG CGA 510 10' HOSE	Striker	Propane	500,000
0384-1251	HS 101 Torch Kit, Fire-Stick, 350,000 BTU's	HS 101 Heating Torch	PPR-LP	LPG 12' Hose		Propane	350,000

# POWDER SPRAY TORCH KIT

Medium Duty Torch Kit

- The Victor VPT-100 provides powder feed into the gas mixture
- Deposit thickness is controlled by the powder flow rate of the torch
- 100 FC Torch Handle
- TE tips: size 3, 4
- TEMF tip: size 6
- 1 lb of Tungsten Carbide #600
- 1 lb of Nickel base #22
- Elbow assembly
- Hopper assembly



Ordering Information							
Part No.	Description	Torch Handle	Torch	Tips	Multi-Flame Tip	Powders	Gas Service
0384-1265	VPT-100 Kit, 100FC Torch Handle, VPT Powder Torch	100FC	VPT 100 Powder Torch	3-TE 4-TE	6-TEMF	1 lb of Nickel Base #22 1 lb of Tungsten Carbide #600	Acetylene





## MODEL NUMBERING EXPLANATION

Single or Two Stage model designations as well as those identifying delivery range are common to all regulators unless otherwise noted on individual ordering charts. When ordering be certain to specify delivery range, CGA inlet connections, and regulator part number.

### Regulator Ordering Matrix

Single Stage Model		Series	Delivery Range		CGA Connection*				
SR	Single Stage	150	Light Duty	A	2-15 psig	CGA 200	Acetylene (MC)	CGA 580	Nitrogen, Argon, Helium
HSR	Single Stage with Flowmeter	250	Medium Duty	B	2-40 psig	CGA 300	Acetylene (Commercial)	CGA 590	Air (Industrial)
VTS	Two Stage Design	350	Heavy Duty	C	4-80 psig	CGA 320	Carbon Dioxide	CGA 660	Corrosive
HVTS	Two Stage with Flowmeter	450	Extra Heavy Duty	D	5-125 psig	CGA 326	Nitrous Oxide	CGA 677	Nitrogen, Argon & Helium
AR	Air Relieving			E	10-200 psig	CGA 346	Air (Formerly 1340)	CGA 680	Nitrogen, Argon
S	Station			F	50-750 psig	CGA 347	Air	CGA 701	Oxygen
L	Line			G	100-1500 psig	CGA 350	Fuel Gas, Hydrogen	CGA 992	British Oxygen & Inert Gas
HRF	Single Stage w/ Internal Flowmeter			J	200-3000 psig	CGA 500	Medical Mixtures	CGA 993	British Fuel Gas
AF	Argon Flow Gauge			K	300-4500 psig	CGA 510	Acetylene (POL)	CGA 996	Manifold Oxygen & Inert Gas
CF	CO2 Flow Gauge					CGA 510LP	Propane, Natural Gas, Propylene	CGA 997	Manifold Fuel Gas
DL	Dome Loaded					CGA 520	Acetylene (B)	CGA 024	Station Oxygen
BSL	Bulk System Line					CGA 540	Oxygen	CGA 025	Station Fuel Gas
DFM	Dual Flowmeter					CGA 555	Propane, Butane	CGA 034	Station Inert Gas
						CGA 577	Oxygen		

#### Ordering Example: SR-250-D-540

Single Stage, 250 Series, with 5-125 Delivery Range, for Oxygen Service CGA 540 Inlet

### Edge Series Regulator Ordering Matrix

Series	Type	Capacity		Max Delivery Pressure	CGA Connection*	Suffix			
E	EDGE Series	SS	Single Stage, Side Inlet	7	High Flow	15, 40, 80, 125, 200, 750, 1500, 3000, 4500	*Same as above Chart	R	Rear Entry
		LC	Liquid Cylinder	4	High Capacity			A	Acetylene
		ST	Station	3	Medium Capacity			F	Fuel Gas
		SL	Line					X	Oxygen
		TS	Two Stage					LP	Liquified Petroleum

#### Ordering Example: ESS4-125-510LP

Edge Series Single Stage, High Capacity w/ up to 125 Delivery Range, for Liquid Petroleum Service CGA 510 Inlet

### Regulator Delivery Ranges

A	2-15 psig	F	50-750 psig
B	2-40 psig	G	100-1500 psig
C	4-80 psig	J	200-3000 psig
D	5-125 psig	K	300-4500 psig
E	10-200 psig		

Outlet pressure delivery ranges are not minimum or maximum outlet pressure limits. Regulators can be adjusted to zero psig outlet pressure and generally, to pressures in excess of those specified. The use of these regulators to control pressures outside of the specified ranges is not recommended.

### Regulator Gauges

A Range	2-30 psig	F Range	50-1000 psig
B Range	2-60 psig	G Range	100-2000 psig
C Range	4-100 psig	J Range	200-4000 psig
D Range	5-200 psig	K Range	200-6000 psig
E Range	10-400 psig		

When ordering regulators, specify part numbers. Regulators should not be used as a shut-off valve nor should they be used to protect downstream equipment. Unless otherwise noted, high pressure gauges for all oxygen, inert gas, CO<sub>2</sub> and N<sub>2</sub>O, and hydrogen models are graduated 200-4000 psig. High pressure gauges for fuel gas models are graduated 10-400 psig. Low pressure or outlet gauge ranges are determined by the regulator delivery range selected.

## HOW TO READ THE FLOW DATA CHARTS:

The regulator flow data is provided to assist in determining the proper regulator for the required application. The data is given for reference purposes only. If additional information is necessary contact your local distributor or the Customer Service Department at 1-800-426-1888

The regulator flow data was established by connecting a valve to the regulator outlet. The valve was opened and the flow rates measured. The amount of pressure drop is shown on the curves as the flow increases.

### Example

An SR 450D with an inlet of 2000 psig and an internal pressure setting of 125 psig (no flow) will flow 1000 SCFH, but the delivery pressure will drop to 115 lb. As the flow increased to 2000 SCFH, the pressure will drop to 108 psig.

With an inlet pressure of 200 psig and an initial setting of 125 psig, the regulator will flow 1000 SCFH with a pressure drop to 98 psig. At 2000 SCFH flow, the pressure will drop to 78 psig. If a delivery pressure other than the ones shown on the flow charts is required, use an average curve rate between the upper and lower pressures shown.

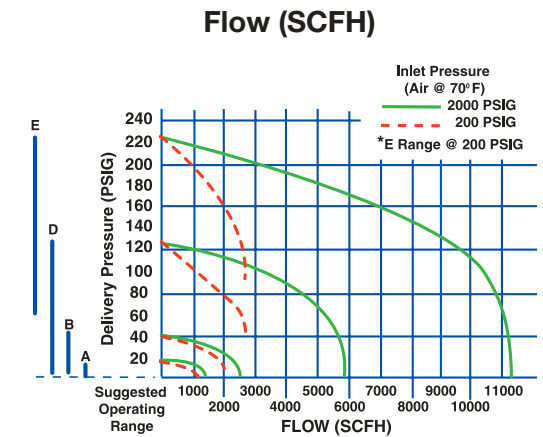

### Delivery Pressure Rise

Single stage regulators have an increase in delivery pressure as the cylinder pressure decreases. Listed below is the amount of pressure increase per 100 psig decrease in cylinder (inlet) pressure.

ESS7-125	.95 psig
ESS7-200	1.54 psig
ESS3-125-540	.53 psig
SR 4 Series	J & K Range 4.8 psig
SR 5 Series	1.0 psig
SR 250 Series	0.5 psig
SR 350 Series	0.8 psig
SR 450 Series	0.6 psig
SR 700 Series	1.2 psig

The change in delivery pressure of a Two Stage regulator from full to empty Cylinder (inlet pressure) is negligible.

### For Conversion to Other Gases

All flow capacity information is given in SCFH of free air (1.00). For conversion to other gases multiply the air flow by the correction factor listed below.

■ Acetylene	1.05
■ Argon	0.85
■ Carbon Dioxide	0.81
■ Helium	2.69
■ Hydrogen	3.79
■ MAP-Pro™	0.82
■ Natural Gas	1.28
■ Nitrogen	1.02
■ Oxygen	0.95
■ Propane	0.80





# REGULATOR SELECTION GUIDE – BY GAS SERVICE

## Acetylene

Description	Model	Part Number	Delivery Range (psig)	Gauge Range Inlet	Gauge Range Outlet	CGA Inlet Connection	Outlet Connection	Max Inlet Pressure (psig)
ESS7 High Capacity Single Stage	ESS7-15-510	0781-5187	2-15	400	30	510	7/8" – 14 LH	3000
ESS7 High Capacity Single Stage	ESS7-200-350	0781-5186	10-200	4000	400	350	7/8" – 14 M LH	3000
ESS42 EDGE 2.0 High Capacity Single Stage	ESS42-15-510	0781-3602	2-15	400	30	510	9/16" – 18 M LH	3000
ESS42 EDGE 2.0 High Capacity Single Stage	ESS42-15-300	0781-3603	2-15	400	30	300	9/16" – 18 M LH	3000
ESS42 EDGE 2.0 High Capacity Single Stage	ESS42-15-993	0781-3604	2-15	400	30	993	9/16" – 18 M LH	3000
ESS42 EDGE 2.0 High Capacity Single Stage	ESS42-15-410	0781-3605	2-15	400	30	410	9/16" – 18 M LH	3000
ESS32 EDGE 2.0 Medium Capacity Single Stage	ESS32-15-510	0781-3628	0-15	400	30	510	9/16" – 18 M LH	3000
ESS32 EDGE 2.0 Medium Capacity Single Stage	ESS32-15-300	0781-3629	0-15	400	30	300	9/16" – 18 M LH	3000
SR 450 Heavy Duty Single Stage	SR460A-300	0781-0583	2-15	400	30	300	9/16" – 18 M LH	3000
SR 450 Heavy Duty Single Stage	SR460A-510	0781-0584	2-15	400	30	510	9/16" – 18 M LH	3000
SR 350 Heavy/Medium Single Stage	SR360A-300	0781-2400	2-15	400	30	300	9/16" – 18 M LH	3000
SR 350 Heavy/Medium Single Stage	SR360A-510	0781-2401	2-15	400	30	510	9/16" – 18 M LH	3000
SR 250 Medium Duty Single Stage	SR260A-300	0781-0085	2-15	400	30	300	9/16" – 18 M LH	3000
SR 250 Medium Duty Single Stage	SR260A-510	0781-0087	2-15	400	30	510	9/16" – 18 M LH	3000
VTS 700 Extra Heavy Duty Two Stage	VTS710A-510	0780-0984	2-15	400	30	510	7/8" – 14 M LH	3000
ETS4 High Capacity Two Stage	ETS4-15-300	0781-5229	2-15	400	30	300	9/16" – 18 M LH	3000
ETS4 High Capacity Two Stage	ETS4-15-510	0781-5230	2-15	400	30	510	9/16" – 18 M LH	3000
ETS4 High Capacity Two Stage	ETS4-15-993	07815-2122	2-15	400	30	993	9/16" – 18 M LH	3000
VTS 250 Medium Duty Two Stage	VTS260A-300	0781-3583	2-15	400	30	300	9/16" – 18 M LH	3000
VTS 250 Medium Duty Two Stage	VTS260A-510	0781-3484	2-15	400	30	300	9/16" – 18 M LH	3000
ESL4 High Capacity Line	ESL4-15-250A	0781-5208	2-15	--	30	1/4" NPT F	1/4" NPT F	350
EST4 High Capacity Station	EST4-15-025	0781-5194	2-15	--	30	025	9/16" – 18 M LH	200
EST4 High Capacity Station	EST4-15-025R	0781-5209	2-15	--	30	025	9/16" – 18 M LH	200
L700 High Flow Line	L710A-500	0780-1233	2-15	--	30	1/2" NPT F	1/2" NPT F	350
L700 High Flow Line	L710A-750	0780-1201	2-15	--	30	3/4" NPT F	3/4" NPT F	350

# REGULATOR SELECTION GUIDE – BY GAS SERVICE

## Air

Description	Model	Part Number	Delivery Range (psig)	Gauge Range Inlet	Gauge Range Outlet	CGA Inlet Connection	Outlet Connection	Max Inlet Pressure (psig)
ESS42 EDGE 2.0 High Capacity Single Stage	ESS42-150-346	0781-3613	5-150	4000	200	346	5/8" – 18 F LH	3000
ESS42 EDGE 2.0 High Capacity Single Stage	ESS42-150-590	0781-3614	5-150	4000	400	590	5/8" – 18 F LH	3000
ESS32 EDGE 2.0 Medium Capacity Single Stage	ESS32-150-346	0781-3637	0-150	4000	200	346	5/8" – 18 F LH	3000
SR 450 Heavy Duty Single Stage	SR450D-346	0781-0532	5-125	4000	200	346	5/8" – 18 F LH	3000
ETS4 High Capacity Two Stage	ETS4-125-346	0781-5231	5-125	4000	200	346	5/8" – 18 F LH	3000
ETS4 High Capacity Two Stage	ETS4-200-346	0781-5232	10-200	4000	400	346	5/8" – 18 F LH	3000
ETS4 High Capacity Two Stage	ETS4-125-590	0781-5224	5-125	4000	200	346	5/8" – 18 F LH	3000
VTS 250 Medium Duty Two Stage	VTS250C-346	0781-3510	4-80	4000	100	346	5/8" – 18 F LH	3000
VTS 250 Medium Duty Two Stage	VTS250D-346	0781-3512	5-125	4000	200	346	5/8" – 18 F LH	3000
SR 4 High Pressure	SR4F-347	0781-1403	50-750	6000	1000	347	1/4" Swagelok®	5500
SR 4 High Pressure	SR4G-346	0781-1422	100-1500	4000	2000	346	1/4" Swagelok	3000
SR 4 High Pressure	SR4J-346	0781-1442	200-3000	4000	4000	346	1/4" Swagelok	3000
SR 4 High Pressure	SR4K-347	0781-1463	300-4500	6000	6000	347	1/4" Swagelok	5500
ESL4 High Capacity Line	ELS4-125-250	0781-5190	5-125	--	200	1/4" NPT F	1/4" NPT F	3000
L700 High Flow Line	L700C-500	0780-1229	4-80	--	100	1/2" NPT F	1/2" NPT F	350
L700 High Flow Line	L700C-750	0780-1220	4-80	--	100	3/4" NPT F	3/4" NPT F	350
L700 High Flow Line	L700D-500	0780-1207	5-125	--	200	1/2" NPT F	1/2" NPT F	350
L700 High Flow Line	L700D-500PMT	0780-1236	5-125	--	200	1/2" NPT F	1/2" NPT F	350
L700 High Flow Line	L700D-750	0780-1209	5-125	--	200	3/4" NPT F	3/4" NPT F	350
L700 High Flow Line	L700E-500	0780-1221	10-200	--	400	1/2" NPT F	1/2" NPT F	350
L700 High Flow Line	L700E-750	0780-1222	10-200	--	400	3/4" NPT F	3/4" NPT F	350
DL700 Dome Load	DL700	0780-1188	5-125	--	--	1/2" NPT F	1/2" NPT F	500

## EDGE Series Color Coding by Gas Type





# REGULATOR SELECTION GUIDE – BY GAS SERVICE

Inert Gas – Nitrogen, Argon, Helium

Description	Model	Part Number	Delivery Range (psig)	Gauge Range Inlet	Gauge Range Outlet	CGA Inlet Connection	Outlet Connection	Max Inlet Pressure (psig)
ESS7 High Capacity Single Stage	ESS7-125-580	0781-5182	5-125	4000	200	580	7/8" – 14 M RH	3000
ESS7 High Capacity Single Stage	ESS7-200-580	0781-5185	10-200	4000	400	580	7/8" – 14 M RH	3000
ESS42 EDGE 2.0 High Capacity Single Stage	ESS42-150-580	0781-3609	5-150	4000	200	580	5/8" – 15 F RH	3000
ESS32 EDGE 2.0 Medium Capacity Single Stage	ESS32-60-580	0781-3633	0-60	4000	60	580	5/8" – 15 F RH	3000
ESS32 EDGE 2.0 Medium Capacity Single Stage	ESS32-150-580	0781-3634	0-150	4000	200	580	5/8" – 15 F RH	3000
SR 450 Heavy Duty Single Stage	SR450D-580	0781-0528	5-125	4000	200	580	5/8" – 18 F RH	3000
SR 450 Heavy Duty Single Stage	SR450E-580	0781-0543	10-200	4000	400	580	5/8" – 18 F RH	3000
VTS Extra Heavy Duty Two Stage	VTS700D-580	0780-0928	5-125	4000	200	580	7/8" – 14 M RH	3000
VTS Extra Heavy Duty Two Stage	VTS700E-580	0780-0943	10-200	4000	400	580	7/8" – 14 M RH	3000
ETS4 High Capacity Two Stage	ETS4-40-580	0781-5221	2-40	4000	60	580	5/8" – 18 F RH	3000
ETS4 High Capacity Two Stage	ETS4-125-580	0781-5222	5-125	4000	200	580	5/8" – 18 F RH	3000
ETS4 High Capacity Two Stage	ETS4-200-580	0781-5223	10-200	4000	400	580	5/8" – 18 F RH	3000
VTS 250 Medium Duty Two Stage	VTS250A-580	0781-3507	2-15	4000	30	580	5/8" – 18 F RH	3000
VTS 250 Medium Duty Two Stage	VTS250B-580	0781-3508	2-40	4000	60	580	5/8" – 18 F RH	3000
VTS 250 Medium Duty Two Stage	VTS250C-580	0781-3509	4-80	4000	100	580	5/8" – 18 F RH	3000
VTS 250 Medium Duty Two Stage	VTS250D-580	0781-3513	5-125	4000	200	580	5/8" – 18 F RH	3000
SR 4 High Pressure	SR4F-580	0781-1408	50-750	4000	1000	580	1/4" Swagelok®	3000
SR 4 High Pressure	SR4F-680	0781-1410	50-750	6000	1000	680	1/4" Swagelok	5500
SR 4 High Pressure	SR4G-580	0781-1428	100-1500	4000	2000	580	1/4" Swagelok	3000
SR 4 High Pressure	SR4G-680	0781-1430	100-1500	6000	2000	680	1/4" Swagelok	5500
SR 4 High Pressure	SR4J-580	0781-1448	200-3000	4000	4000	580	1/4" Swagelok	3000
SR 4 High Pressure	SR4J-680	0781-1450	200-3000	6000	4000	680	1/4" Swagelok	5500
SR 4 High Pressure	SR4J-677	0781-1453	200-3000	7500	4000	677	1/4" Swagelok	7500
SR 4 High Pressure	SR4K-680	0781-1470	300-4500	6000	6000	680	1/4" Swagelok	5500
SR 4 High Pressure	SR4K-677	0781-1473	300-4500	7500	6000	677	1/4" Swagelok	7500
ELC4 High Capacity Liquid Cylinder	ELC4-125-580R	0781-5200	5-125	–	200	580	CGA 032 5/8" – 18 UNF	3000
ELC4 High Capacity Liquid Cylinder	ELC4-325-580R	0781-5202	5-325	–	400	580	CGA 032 5/8" – 18 UNF	3000
EST4 High Capacity Station	EST4-125-034	0781-5189	5-125	–	200	034	CGA 032 5/8" – 18 UNF	200
EST4 High Capacity Station	EST4-125-034R	0781-5207	5-125	–	200	034	CGA 032 5/8" – 18 UNF	200
L700 High Flow Line	L700C-500	0780-1229	4-80	–	100	1/2" NPT F	1/2" NPT F	350
L700 High Flow Line	L700C-750	0780-1220	4-80	–	100	3/4" NPT F	3/4" NPT F	350
L700 High Flow Line	L700D-500	0780-1207	5-125	–	200	1/2" NPT F	1/2" NPT F	350
L700 High Flow Line	L700D-500PMT	0780-1236	5-125	–	200	1/2" NPT F	1/2" NPT F	350
L700 High Flow Line	L700D-750	0780-1209	–	–	200	3/4" NPT F	3/4" NPT F	350
L700 High Flow Line	L700E-500	0780-1221	10-200	–	400	1/2" NPT F	1/2" NPT F	350
L700 High Flow Line	L700E-750	0780-1222	10-200	–	400	3/4" NPT F	3/4" NPT F	350
DL700 Dome Load	DL700	0780-1188	5-125	–	–	1/2" NPT F	1/2" NPT F	500
BSL Bulk System Line	BSL700	0780-1200	10-200	–	–	1/2" NPT F	1/2" NPT F	350

# REGULATOR SELECTION GUIDE – BY GAS SERVICE

Inert Gas – Nitrogen, Argon, Helium (continued)

Description	Model	Part Number	Delivery Range (psig)	Gauge Range Inlet	Gauge Range Outlet	CGA Inlet Connection	Outlet Connection	Max Inlet Pressure (psig)
ESS3-FG Flow Gauge	ESS3-FG-580	0781-5120	0-40 psig	4000	50 CFH	580	CGA 032 5/8" – 18 UNF	3000
SLR 100 Surge Limiting Regulator	SLR100	0781-1197		--	--	030		200
FM150 Flowmeter Heavy Duty	FM150	1000-0268	10-60 Air* 10-30 Nit*	--	--	1/4" NPT M	5/8"-18 RH F	25
FM135 Flowmeter Heavy Duty	FM135	1000-0255	4-18 Argon* 10-50 Helium*	--	--	9/16"-18 RH F	5/8"-18 RH F	25
FM145 Flowmeter Heavy Duty	FM145	1000-0256	4-18 Argon* 10-50 Helium*	--	--	5/8" RH M	5/8"-18 RH F	25
FM155 Flowmeter Heavy Duty	FM155	1000-0257	4-18 Argon* 10-50 Helium*	--	--	5/8" NPT M	5/8"-18 RH F	25
FM137 Flowmeter Heavy Duty	FM137	1000-0261	15-65 Argon* 40-200 Helium*	--	--	9/16"-18 RH F	5/8"-18 RH F	25
FM147 Flowmeter Heavy Duty	FM147	1000-0262	15-70 Argon* 40-200 Helium*	--	--	5/8"-18 RH M	5/8"-18 RH F	25
FM157 Flowmeter Heavy Duty	FM157	1000-0263	15-65 Argon* 40-200 Helium*	--	--	1/4" NPT M	5/8"-18 RH F	25
FM370 Flowmeter Heavy Duty	FM370	1000-0258	5-50 Argon* 20-150 Helium*	--	--	9/16"-18 RH F	5/8"-18 RH F	25
FM371 Flowmeter Heavy Duty	FM371	1000-0259	5-50 Argon* 20-150 Helium*	--	--	5/8"-18 RH M	5/8"-18 RH F	25
FM372 Flowmeter Heavy Duty	FM372	1000-0182	5-50 Argon* 20-150 Helium*	--	--	1/4" NPT M	5/8"-18 RH F	25
HRF 2425 Medium Duty Flowmeter Regulator	HRF2425	0781-2731	10-50 Argon* 20-150 Helium*	--	--	580	5/8"-18 RH F	3000
HRF2480 Medium Duty Flowmeter Regulator	HRF2480	0781-2728	7.5-37.5 Argon*	--	--	580	5/8"-18 RH F	3000
DFM 150 Medium Duty Flowmeter Regulator	DFM150-580	0781-1153	5-50 Argon* 20-150 Helium*	--	--	580	5/8"-18 RH F	3000
HSR Medium Duty Flowmeter Regulator Single Stage	HSR2530	0781-3819	10-60 Nitrogen*	--	--	580	5/8"-18 RH F	3000
HSR Medium Duty Flowmeter Regulator Single Stage	HSR2535	0781-3867	4-18 Argon* 10-50 Helium*	--	--	580	5/8"-18 RH F	3000
HVTS Medium Duty Flowmeter Regulator Two Stage	HVTS2535	0781-3775	4-18 Argon* 10-50 Helium*	--	--	580	5/8"-18 RH F	3000
HSR Medium Duty Flowmeter Regulator Single Stage	HSR2537	0781-3871	15-65 Argon* 40-200 Helium*	--	--	580	5/8"-18 RH F	3000
HVTS Medium Duty Flowmeter Regulator Two Stage	HVTS2537	0781-3772	15-65 Argon* 40-200 Helium*	--	--	580	5/8"-18 RH F	3000
HSR Medium Duty Flowmeter Regulator Single Stage	HSR2570	0781-3873	5-50*	--	--	580	5/8"-18 RH F	3000
HSR Medium Duty Flowmeter Regulator Single Stage	HSR2570	0781-3869	4-40*	--	--	580	5/8"-18 RH F	3000
HVTS Medium Duty Flowmeter Regulator Two Stage	HVTS2570	0781-3774	20-150*	--	--	580	5/8"-18 RH F	3000

\*Delivery range measured in CFH

GAS CONTROL

GAS CONTROL



# REGULATOR SELECTION GUIDE – BY GAS SERVICE

## British Oxygen

Description	Model	Part Number	Delivery Range (psig)	Gauge Range Inlet	Gauge Range Outlet	CGA Inlet Connection	Outlet Connection	Max Inlet Pressure (psig)
ESS4 High Capacity Single Stage	ESS4-125-992	0781-5128	5-125	4000	200	992	9/16" – 18 M RH	3000
ETS4 High Capacity Two Stage	ETS4-125-992	0785-2120	5-125	4000	200	992	9/16" – 18 M RH	3000
ETS4 High Capacity Two Stage	ETS4-200-992	0785-2121	10-200	4000	400	992	9/16" – 18 M RH	3000
DL700 Dome Load	DL700	0780-1188	5-125	–	–	1/2" NPT F	1/2" NPT F	500

## Methane/Hydrogen

Description	Model	Part Number	Delivery Range (psig)	Gauge Range Inlet	Gauge Range Outlet	CGA Inlet Connection	Outlet Connection	Max Inlet Pressure (psig)
ESS7 High Capacity Single Stage	ESS7-200-350	0781-5186	10-200	4000	400	350	7/8" – 14 M RH	3000
ESS42 EDGE 2.0 High Capacity Single Stage	ESS42-150-350	0781-3612	5-150	4000	200	350	1/4" – 18 F	3000
ETS4 High Capacity Two Stage	ETS4-40-350	0781-5225	2-40	4000	60	350	9/16" – 18 M LH	3000
VTS 250 Medium Duty Two Stage	VTS252A-350	0781-3558	2-15	4000	30	350	9/16" – 18 M LH	3000
VTS 250 Medium Duty Two Stage	VTS252B-350	0781-3559	2-40	4000	60	350	9/16" – 18 M LH	3000
VTS 250 Medium Duty Two Stage	VTS252C-350	0781-3563	4-80	4000	100	350	9/16" – 18 M LH	3000
VTS 250 Medium Duty Two Stage	VTS252D-350	0781-3564	5-125	4000	200	350	9/16" – 18 M LH	3000
SR 4 High Pressure Manifold	SR4F-350	0781-1404	50-750	4000	1000	350	1/4" Swagelok®	3000
SR 4 High Pressure Manifold	SR4G-350	0781-1424	100-1500	4000	2000	350	1/4" Swagelok	3000
SR 4 High Pressure Manifold	SR4J-350	0781-1444	200-3000	4000	4000	350	1/4" Swagelok	3000
ESL4 High Capacity Line	ESL4-80-250F	0781-5210	4-80	–	100	1/4" NPT F	1/4" NPT F	3000
ESL4 High Capacity Line	ESL4-125-250F	0781-5211	5-125	–	200	1/4" NPT F	1/4" NPT F	3000
EST4 High Capacity Station	EST4-80-025	0781-5195	4-80	–	100	025	9/16" – 18 M LH	200
EST4 High Capacity Station	EST4-80-025R	0781-5212	4-80	–	100	025	9/16" – 18 M LH	200
EST4 High Capacity Station	EST4-125-025	0781-5196	5-125	–	200	025	9/16" – 18 M LH	200
EST4 High Capacity Station	EST4-125-025R	0781-5213	5-125	–	200	025	9/16" – 18 M LH	200
L700 High Flow Line	L711D-500	0780-1199	5-125	–	200	1/2" NPT F	1/2" NPT F	350
HSR Medium Duty Flowmeter Regulator Single Stage	HSR2533	0781-3825	5-40*	–	–	350	9/16" – 18 M LH	3000

## Nitrous Oxide

Description	Model	Part Number	Delivery Range (psig)	Gauge Range Inlet	Gauge Range Outlet	CGA Inlet Connection	Outlet Connection	Max Inlet Pressure (psig)
ESL4 High Capacity Line	ESL4-125-250	0781-5190	5-125	–	200	1/4" NPT F	1/4" NPT F	3000
DL700 Dome Load	DL700	0780-1188	5-125	–	–	1/2" NPT F	1/2" NPT F	500

# REGULATOR SELECTION GUIDE – BY GAS SERVICE

## Carbon Dioxide

Description	Model	Part Number	Delivery Range (psig)	Gauge Range Inlet	Gauge Range Outlet	CGA Inlet Connection	Outlet Connection	Max Inlet Pressure (psig)
ESS42 EDGE 2.0 High Capacity Single Stage	ESS42-150-320	0781-3615	5-150	4000	400	320	CGA 032 5/8" – 15 F RH	3000
ESS32 EDGE 2.0 Medium Capacity Single Stage	ESS32-150-320	0781-3638	0-150	4000	200	320	CGA 032 5/8" – 15 F RH	3000
ETS4 High Capacity Two Stage	ETS4-125-320	0781-5228	5-125	4000	200	320	CGA 032 5/8" – 18 UNF	3000
VTS 250 Medium Duty Two Stage	VTS253A-320	0781-3569	2-15	4000	30	320	CGA 032 5/8" – 18 UNF	3000
VTS 250 Medium Duty Two Stage	VTS253B-320	0781-3573	2-40	4000	60	320	CGA 032 5/8" – 18 UNF	3000
VTS 250 Medium Duty Two Stage	VTS253C-320	0781-3574	4-80	4000	100	320	CGA 032 5/8" – 18 UNF	3000
VTS 250 Medium Duty Two Stage	VTS253D-320	0781-3575	5-125	4000	200	320	CGA 032 5/8" – 18 UNF	3000
SR 4 High Pressure Manifold	SR4F-320	0781-1401	50-750	4000	1000	320	CGA 032 5/8" – 18 UNF	3000
ELC4 High Capacity Liquid Cylinder	ELC4-125-320R	0781-5201	5-125	–	200	320	CGA 032 5/8" – 18 UNF	3000
ESL4 High Capacity Line	ESL4-125-250	0781-5190	5-125	–	200	1/4" NPT F	1/4" NPT F	3000
DL700 Dome Load	DL700	0780-1188	5-125	–	–	1/2" NPT F	1/2" NPT F	500
ESS3-FG Flow Gauge	ESS3-FG-320	0781-5119	0-40*	4000	50 CFH	320	CGA 032 5/8" – 18 UNF	3000
SR310 Regulator Adjustable Pressure	SR310	0781-0355	10-150*	1500	200	320	CGA 032 5/8" – 18 UNF	1500
SR311 Flowmeter	SR311	0781-0353	25-100*	1500	–	320	CGA 032 5/8" – 18 UNF	1500
SR312 Flow Gauge	SR312	0781-0354	0-100*	–	–	320	CGA 032 5/8" – 18 UNF	1500
FM200 Heavy Duty Flowmeter	FM200	1000-0264	30-100*	–	–	1/4" NPT M	5/8"-18RH M	30
FM370 Flowmeter Heavy Duty	FM370	1000-0258	5-40*	–	–	9/16"-18 RH F	5/8"-18 RH F	25
FM371 Flowmeter Heavy Duty	FM371	1000-0259	5-40*	–	–	5/8"-18 RH M	5/8"-18 RH F	25
FM372 Flowmeter Heavy Duty	FM372	1000-0182	5-40*	–	–	1/4" NPT M	5/8"-18 RH F	25
HRF2480 Medium Duty Flowmeter Regulator	HRF2480	0781-2727	10-38*	–	–	320	5/8"-18 RH F	3000
HRF2480 Medium Duty Flowmeter Regulator	HRF2480	0781-2728	7.5-37.5*	–	–	320	5/8"-18 RH F	3000
DMF150 Medium Duty Flowmeter Regulator	DMF150S	0781-1206	5-40*	–	–	1/4" NPT M	5/8"-18 RH F	3000
HSR Medium Duty Flowmeter Regulator	HSR2530	0781-3819	10-60*	–	–	580	5/8"-18 RH F	3000

\*Delivery Range measured in CFH

## L.P. Gas

Description	Model	Part Number	Delivery Range (psig)	Gauge Range Inlet	Gauge Range Outlet	CGA Inlet Connection	Outlet Connection	Max Inlet Pressure (psig)
ESS7 High Capacity Single Stage	ESS7-125-510LP	0781-5188	5-125	400	200	510	7/8" – 14 M LH	350
ESS42 EDGE 2.0 High Capacity Single Stage	ESS42-60-510LP	0781-3606	2-60	510	60	510	9/16" – 18 M LH	350
ESS42 EDGE 2.0 High Capacity Single Stage	ESS42-150-510LP	0781-3607	2-150	510	200	510	9/16" – 18 M LH	350
ESS32 EDGE 2.0 Medium Capacity Single Stage	ESS32-60-510LP	0781-3631	0-60	510	60	510	9/16" – 18 M LH	350
SR450 Heavy Duty Single Stage	SR461B-510	0781-0589	2-40	400	60	510	9/16" – 18 M LH	350
SR450 Heavy Duty Single Stage	SR461D-510	0781-0595	5-125	400	200	510	9/16" – 18 M LH	350
SR 250 Medium Duty Single Stage	SR261B-510	0781-0095	2-40	400	60	510	9/16" – 18 M LH	350
SR 250 Medium Duty Single Stage	SR261C-510	0781-0098	4-80	400	100	510	9/16" – 18 M LH	350
VTS 250 Medium Duty Two Stage	VTS261B-510	0781-3594	2-40	400	60	510	9/16" – 18 M LH	350
VTS 250 Medium Duty Two Stage	VTS250BL-555	0781-3525	2-40	400	60	510	9/16" – 18 M LH	350
ESL4 High Capacity Line	ESL4-80-250F	0781-5210	4-80	–	100	1/4" NPT F	1/4" NPT F	3000
ESL4 High Capacity Line	ESL4-125-250F	0781-5211	5-125	–	200	1/4" NPT F	1/4" NPT F	3000
EST4 High Capacity Station	EST4-80-025	0781-5195	4-80	–	100	025	9/16" – 18 M LH	200
EST4 High Capacity Station	EST4-80-025R	0781-5212	4-80	–	100	025	9/16" – 18 M LH	200
EST4 High Capacity Station	EST4-125-025	0781-5196	5-125	–	20	025	9/16" – 18 M LH	200
EST4 High Capacity Station	EST4-125-025R	0781-5213	5-125	–	200	025	9/16" – 18 M LH	200
L700 High Flow Line	L711D-500	0780-1199	5-125	–	200	1/2" NPT F	1/2" NPT F	350



# SINGLE STAGE REGULATORS

Recommended for applications where slight delivery pressure increases (due to decreasing cylinder pressures) would not affect the performance characteristics of the work or test results.

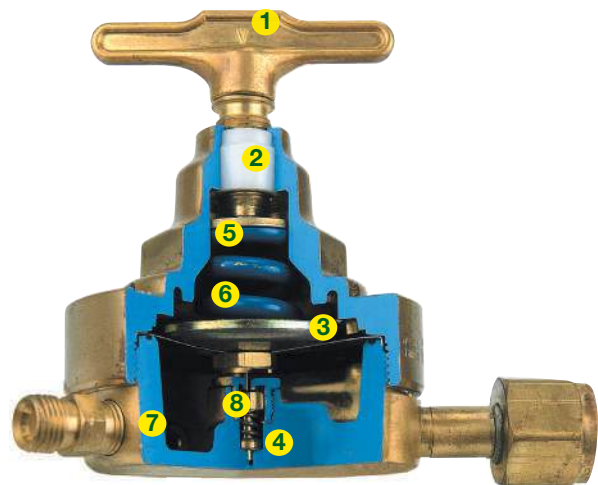

Typical Single Stage Design SR 450 Series Shown  
2.5 in. (63.5 mm) Brass Gauges External Relief Valve System

- 1 Brass Adjusting Screw with forged T-handle (SR 450 only)
- 2 Delrin Insert Bushing for durability, easier adjusting
- 3 Stainless Steel Diaphragm gives accurate long lasting service
- 4 Stem-Type Seat Mechanism inlet pressure aids in sealing
- 5 Stainless Ball in Key for easy adjustment
- 6 Adjusting Spring pretested for quality assurance
- 7 Die-Forged Brass Body for extra strength
- 8 Precision Machined Nozzle for optimum flow control

### Additional Features

- External self reseating relief valve. Not designed to protect downstream equipment (no relief valve is needed on low pressure fuel gas models)
- Sintered inlet filter, electroless nickel plated bronze
- Regulators will deliver at least the stated upper range and in some cases may exceed the stated upper range

# TWO STAGE REGULATORS

Recommended for applications that require a constant delivery pressure over a range of decreasing inlet pressures. This precise two stage regulator provides superior operating characteristics for applications where change in delivery pressure would affect performance characteristics of work or test results.

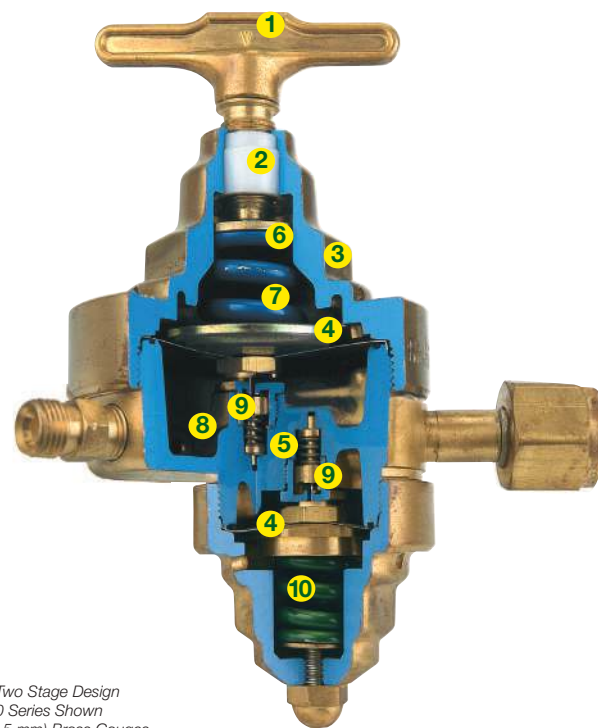

Typical Two Stage Design  
VTS 450 Series Shown  
2.5" (63.5 mm) Brass Gauges  
External Relief Valve System

### Additional Features

- 1 Brass Adjusting Screw with forged T-handle (VTS 700 only)
- 2 Delrin Insert Bushing for durability, easier adjusting
- 3 Die-Forged Brass Spring Housing Cap provides greater strength and durability
- 4 Stainless Steel Diaphragm gives accurate long lasting service
- 5 Stem-Type Seat Mechanism inlet pressure aids in sealing
- 6 Stainless Ball in Key for easy adjustment
- 7 Adjusting Spring pretested for quality assurance
- 8 Die-Forged Brass Body for extra strength
- 9 Precision Machined Nozzle for optimum flow control
- 10 Adjusting Spring designed for precise preset

### Additional Features

- External self reseating relief valve. Not designed to protect downstream equipment (no relief valve is needed on low pressure fuel gas models)
- Sintered inlet filter, electroless nickel plated bronze
- Regulators will deliver at least the stated upper range and in some cases may exceed the stated upper range

# EDGE™ SERIES

Innovative EDGE Series Regulators Offer Safety and Advanced Design

Victor has been the leader in gas equipment for one hundred years, and its tradition of unparalleled safety remains a cornerstone of the brand today. With the Victor Professional EDGE Series Regulators, Victor continues to offer the safest, most reliable and highest quality gas control technology, giving you more value for your purchase. In addition, standardized designs and components throughout the EDGE family greatly simplify regulator service and repair.

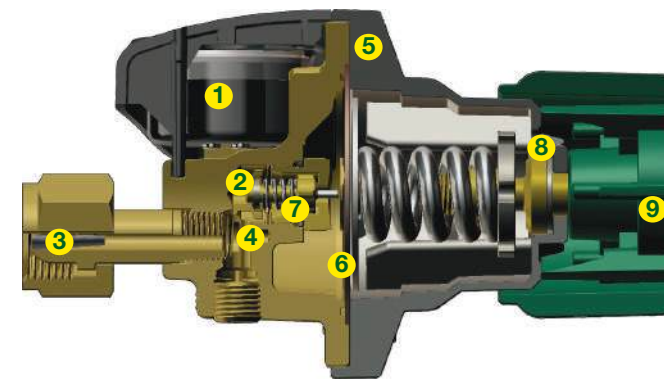

- 1 Gauges are recessed into the body for the highest level of safety and protection possible
- 2 More efficient internal flow paths translate to improved flow consistency from full to empty cylinder
- 3 Same sintered inlet filter used in all Victor industrial regulators
- 4 Innovative design elements enable the regulator to meet or exceed oxygen-related safety standards CGA E-4, UL 252, and the stringent ASTM G-175 Promoted Ignition Test
- 5 Housing cap is made from high strength zinc-aluminum alloy that has nearly twice the yield strength of forged brass
- 6 Time-tested fabric reinforced neoprene diaphragm provides superior sensitivity and control
- 7 Seat assembly and friction damper are the same tried and true components used for decades in SR 350 and SR 450
- 8 Internals remain protected from weather elements through an internal vent system protected under the knob, which is channeled to promote water run-off
- 9 SLAM™ Knob designed with multi-stage crumple zones which absorb impact energy in the event the cylinder falls over. Helps protect pressure integrity of both regulator and cylinder valve.



Single Impact Point

### 3-Stage Crumple Zone

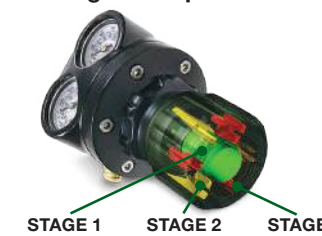

Shock Absorbing Knob

# EDGE 2.0 SERIES REGULATORS

High and Medium Capacity, Single Stage Regulators

Victor EDGE™ Series 2.0 patented regulators are second generation, heavy duty, high capacity single stage cylinder regulators that reset the standard for industrial regulators.

New and improved gauge designs incorporate larger faced delivery gauge (low pressure) with high contrasted colored face for easy setting. Enhanced color-coded knob designs provide more comfortable operations.

Air, Oxygen, Inert Gas, Methane, Hydrogen, Carbon Dioxide, Acetylene and LP Gas (see ordering information).

- Forged brass body
- External self reseating relief valve. Not designed to protect downstream equipment (no relief valve is needed on low pressure fuel gas models).
- Fully enclosed, highly visible modular gauges for more clarity with robust metal gauge guard
- Extra large 2 1/2 in. (63.5 mm) delivery gauge and stainless steel diaphragm
- Robust seat gives optimum performance
- Consistent pressure and flow delivery
- High resistance to oxygen related fires and SLAM knob absorbs impact in the event of a cylinder fall





# ESS42 EDGE 2.0

High Capacity, Single Stage

### Design/Construction

- Fully enclosed, highly visible modular gauges for more clarity with robust metal gauge guard
- Extra large 2 1/2 in. (63.5 mm) delivery gauge and stainless steel diaphragm
- Robust seat gives optimum performance
- Consistent pressure and flow delivery
- High resistance to oxygen related fires and SLAM knob absorbs impact in the event of a cylinder fall



# ESS32 EDGE 2.0

Medium Capacity, Single Stage

### Design/Construction

- Fully enclosed, highly visible modular gauges for more clarity with robust metal gauge guard
- Large 2 in. (50.8 mm) delivery gauge
- Robust seat gives optimum performance
- Consistent pressure and flow delivery
- High resistance to oxygen related fires and SLAM knob absorbs impact in the event of cylinder fall



### ESS42 Flow Data

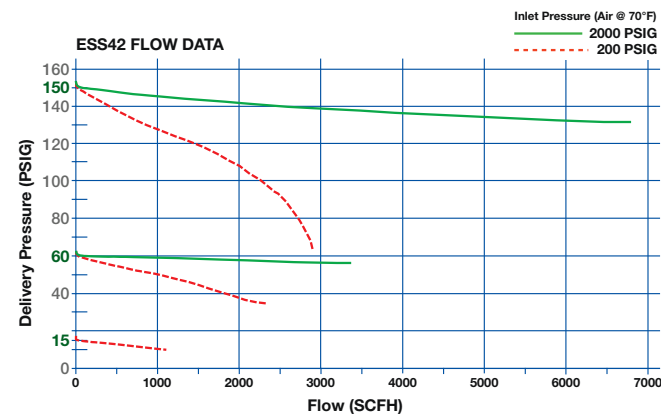

### ESS32 Flow Data

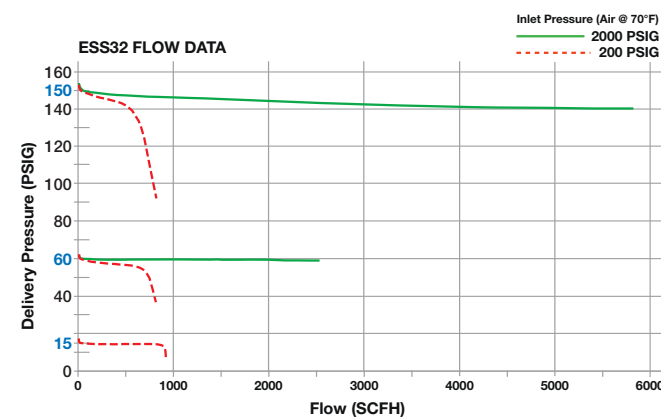

### Specifications

Dimensions L x W x H	Weight
4 x 6 x 4 in. (101.6 x 152.4 x 101.6 mm)	4.0 lbs (1.81kg)

### Specifications

Dimensions L x W x H	Weight
4 x 6 x 4 in. (101.6 x 152.4 x 101.6 mm)	4.0 lbs (1.81kg)

### Ordering Information

Gas Service	Part No.	Model No.	Delivery Range (psig)
Air, Oxygen, Inert Gas	0781-3600	ESS42-60-540 Oxygen	2-60
	0781-3601	ESS42-150-540 Oxygen	5-150
	0781-3613	ESS42-150-346 Air	5-150
	0781-3614	ESS42-150-590 Air	5-150
	0781-3609	ESS42-150-580 Inert Gas	5-150
Methane/Hydrogen	0781-3612	ESS42-150-350	5-150
	0781-3602	ESS42-15-510	2-15
Acetylene	0781-3603	ESS42-15-300	2-15
	0781-3604	ESS42-15-993	2-15
	0781-3605	ESS42-15-410	2-15
	L.P. Gas	0781-3606	ESS42-60-510LP
0781-3607		ESS42-150-510LP	2-150
Carbon Dioxide	0781-3615	ESS42-150-320	5-150

### Ordering Information

Gas Service	Part No.	Model No.	Delivery Range
Air, Oxygen, Inert Gas	0781-3627	ESS32-60-540 S/S Oxygen	0-60 psig
	0781-3626	ESS32-150-540 S/S Oxygen	0-150 psig
	0781-3633	ESS32-60-580 Inert	0-60 psig
	0781-3634	ESS32-60-580 Inert	0-150 psig
	0781-3637	ESS32-150-346 S/S Air	0-150 psig
Methane/Hydrogen	0781-3635	ESS32-60-350 S/S Hydrogen	0-60 psig
	0781-3636	ESS32-150-350 S/S Hydrogen	0-150 psig
Acetylene	0781-3628	ESS32-15-510 S/S Acetylene	0-15 psig
	0781-3629	ESS32-15-300 S/S Acetylene	0-15 psig
L.P. Gas	0781-3631	ESS32-60-510LP S/S LP	0-60 psig
Carbon Dioxide	0781-3638	ESS32-150-320 S/S CO2	0-150 psig
Ar-CO2	0781-3641	ESS32-80CFH-580 Ar-CO2 Flowgauge	0-80 cfh
	0781-3642	ESS32-80CFH-320 Ar-CO2 Flowgauge	0-80 cfh

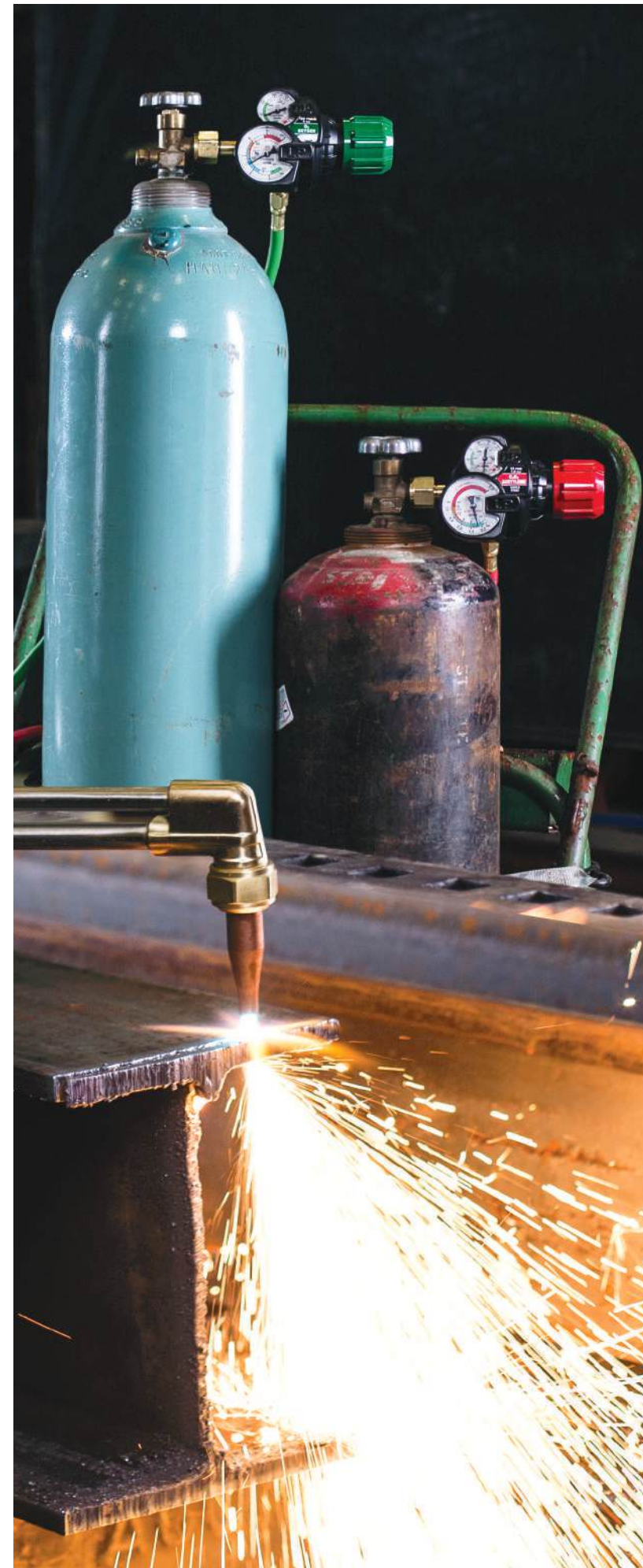

# SR 450

Heavy Duty



### Design/Construction

- 2.5 in. (63.5 mm) gauges – brass
- 3.25 in. (82.6 mm) diaphragm – stainless steel

The shape of the SR450 Series regulator is a registered trademark of Victor.

### Flow (SCFH)

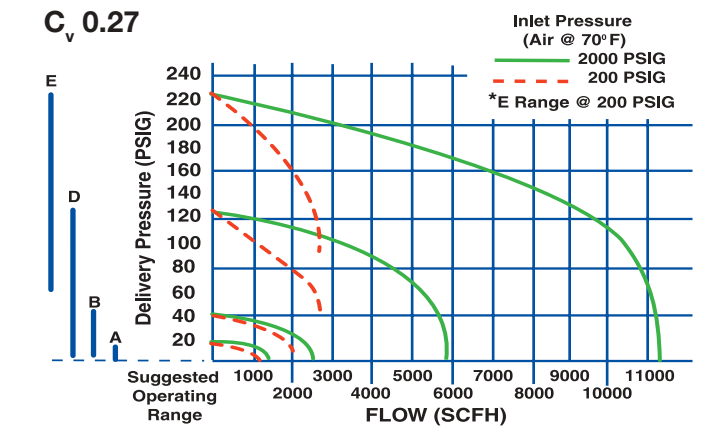

### Specifications

Maximum Inlet	Dimensions L x W x H	Weight
3000 psig	5.13 x 7.25 x 7 in. (130.3 x 184.2 x 177.8 mm)	5 lbs 2 oz (2.32 kg)

### Ordering Information

Gas Service	Part No.	Model No.	Delivery Range (psig)
Air, Oxygen, Inert Gas	0781-0532	SR 450D-346	5-125
	0781-0527	SR 450D-540	5-125
	0781-0528	SR 450D-580*	5-125
	0781-0543	SR 450E-580*	10-200
Acetylene	0781-0583	SR 460A-300	2-15
	0781-0584	SR 460A-510	2-15
L.P. Gas	0781-0589	SR 461B-510	2-40
	0781-0595	SR 461D-510	5-125

Outlet Connections: Cylinder Type – 9/16"-18 (M), 9/16"-18 (F) RH



### SR 350 Heavy/Medium Duty



### SR 250 Medium Duty



### G350 Heavy Duty



### G250 Medium Duty



#### Design/Construction

- High impact ABS gauge guard
- 1.5 in. (40 mm) gauges steel
- 2.7 in. (68.6 mm) diaphragm – fabric reinforced neoprene

#### Design/Construction

- 2 in. (50.8 mm) gauges – brass
- 1.75 in. (44.5 mm) diaphragm – fabric reinforced neoprene

#### Design/Construction

- Larger regulator body for heavy duty applications
- Color coded knobs
- Forged brass body and Zinc Aluminum housing cap
- 2 1/2 in. (63 mm) high contrast gauges
- 9/16"-18 outlet connection
- Internal relief

#### Design/Construction

- Compact size for light to medium duty applications
- Acetylene, Oxygen and LP gas models
- Color coded knobs
- Single stage
- Forged brass body & Zinc Aluminum housing cap
- 2 in. (50.8 mm) gauges
- Delivery ranges vary based on model (see ordering information)
- 9/16"-18 outlet connection
- Internal relief

#### SR350 Flow Data - (Flowing Air at STD. Conditions)

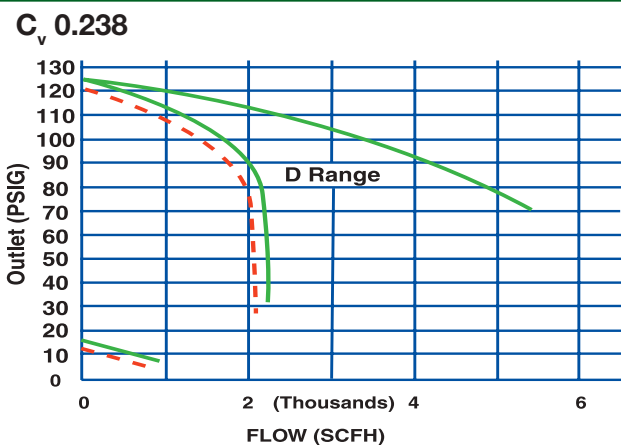

#### SR250 Flow Data

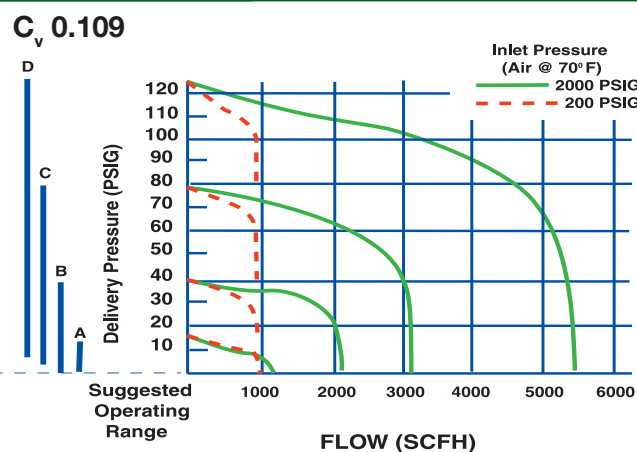

#### G350 Flow Data

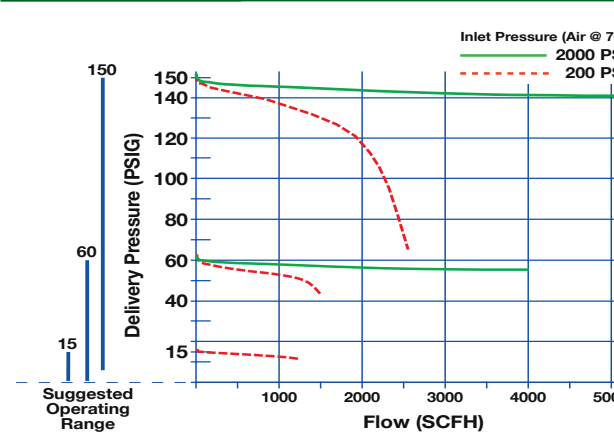

#### G250 Flow Data

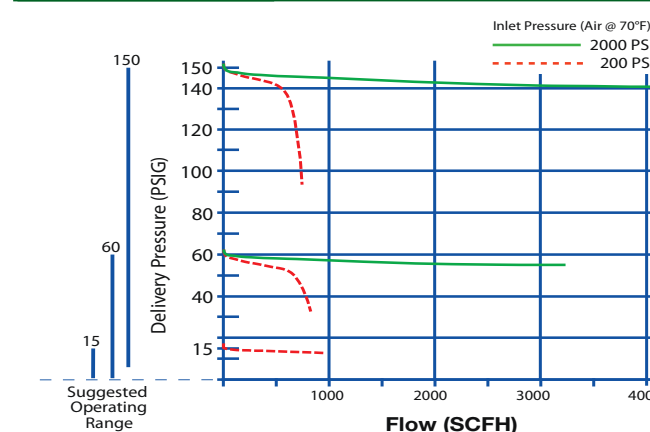

#### Specifications

Maximum Inlet	Dimensions L x W x H	Weight
3000 psig	4.5 x 7.5 x 6.5 in. (114.3 x 190.5 x 165.1 mm)	4 lb (1.8 kg)

#### Specifications

Maximum Inlet	Dimensions L x W x H	Weight
3000 psig	4.25 x 6.38 x 5.13 in. (108 x 162 x 130.3 mm)	2 lbs 15 oz (1.3 kg)

#### Ordering Information

Gas Service	Part No.	Model No.	Delivery Range (psig)
Oxygen	0781-2341	SR 350D-540	5-125
Acetylene	0781-2400	SR 360A-300**	2-15
	0781-2401	SR 360A-510	2-15

Outlet Connections: Cylinder Type – 9/16"-18 (M), \*\*9/16"-18 (M) LH

#### Ordering Information

Gas Service	Part No.	Model No.	Delivery Range (psig)
Oxygen	0781-0027	SR 250C-540	4-80
	0781-0043	SR 250D-540	5-125
Acetylene	0781-0085	SR 260A-300	2-15
	0781-0087	SR 260A-510	2-15
	0387-0115	SR 260A-510 CS	2-15
L.P. Gas	0781-0095	SR 261B-510	2-40
	0781-0098	SR 261C-510	4-80

CS = Clamshell Packaging  
Outlet Connections: Cylinder Type – 9/16"-18 (M)

#### Ordering Information

Gas Service	Part No.	Model No.	Delivery Range (psig)
Oxygen	0781-9433	G350-150-540	150
	0781-9430	G350-15-510	15
Acetylene	0781-9431	G350-15-300	15
	0781-9435 (WQ)	G350-15-510WQ	15
Inert	0781-0934	G350-150-580	150
LP	0781-9432	G350-60-510LP	60
Dual Packs	0781-3287	G350-150-540	150
		G350-15-510	15
	0781-3288	G350/300	60
		G350-15-300	15

#### Ordering Information

Gas Service	Part No.	Model No.	Delivery Range (psig)
Oxygen	0781-9400	G250-150-540	150
	0781-9405	G250-15-510	15
Acetylene	0781-9406	G250-15-300	15
	0781-9410	G250-60-510LP	60





# GF250

Medium Duty

### Design/Construction

- Dual 2" gauges
- High strength alloy bonnet
- Single stage design
- Ergonomic adjusting knob
- For Argon or Argon/CO<sub>2</sub> mix shielding gases
- Color scale graphics with MIG and TIG ranges



# G150

Light Duty, Single Stage, Cylinder Regulator

The G150 series, single stage, cylinder regulator is a compact, light weight regulator engineered for light duty applications.

### Design/Construction

- Ergonomic color-coded adjustment knob
- High contrast gauge face
- High strength alloy bonnet
- Compact design



### G150 Flow Data

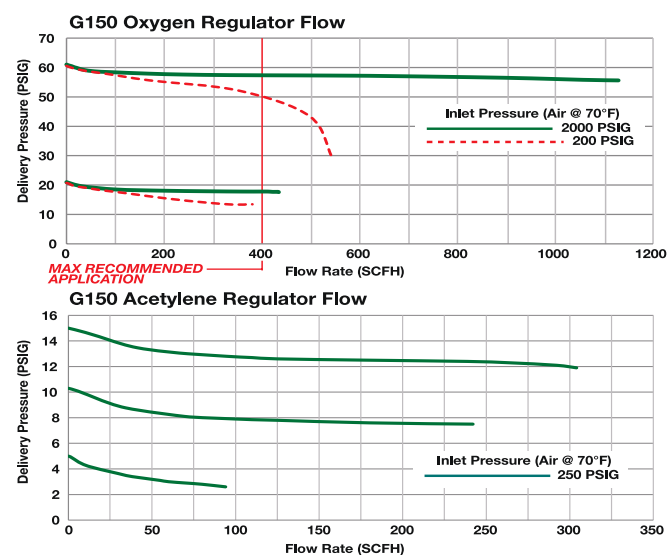

### Specifications

Maximum Inlet	Weight
3000 psig	2.10 lbs (1.22 kg)

### Ordering Information

Part No.	Description
0781-9411	GF250-50-580
0781-9412	GF250-50-580 with 10 ft (3.1 m) hose

### Ordering Information

G150-60-540	0781-4227
G150-60-540R	0781-4228
G150-60-540R 020 "A"	0781-4241
G150-15-510	0781-4233
G150-15-200	0781-4231
G150-15-200R	0781-4232
G150-15-200R 021 "A"	0781-4240
G150-15-520	0781-4235
G150-60-510LP	0781-4234
G150-60-580	0781-4229
G150-60-580 with hose	0781-4236
GF150-50-580 flowgauge	0781-4226
G150-60-320	0781-4230
GF150-50-320 with hose	0781-4237
GF150-50-320 flowgauge	0781-4225
SLR150 surge limiting	0781-1207

# ESS7

High Flow

### Design/Construction

- 2.5 in. (63.5 mm) gauges – brass
- 2.7 in. (68.6 mm) diaphragm – fabric reinforced neoprene



### ESS7 Flow Data - EDGE Series High-Flow

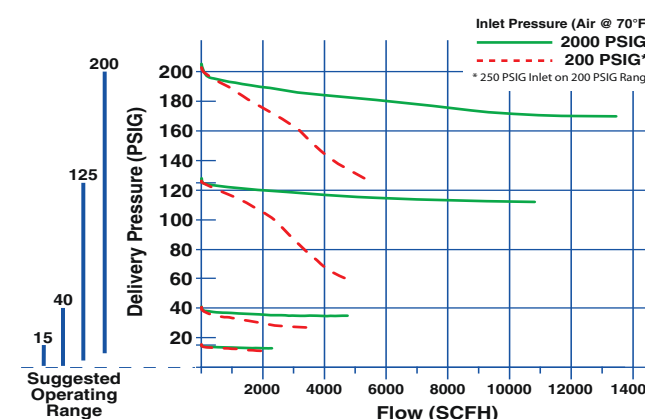

### Specifications

Dimensions L x W x H	Weight
5.4 x 6.8 x 6.9 in. (137.1 x 172.7 x 175.3 mm)	4.9 lbs (2.22 kg)

### Ordering Information

Gas Service	Part No.	Model No.	Delivery Range
Air, Oxygen, Inert Gas	0781-5184	ESS7-200-346	10-200
	0781-5181	ESS7-125-540	5-125
	0781-5183	ESS7-200-540	10-200
	0781-5220	ESS7-200-992	10-200
	0781-5182	ESS7-125-580	5-125
	0781-5185	ESS7-200-580	10-200
Methane/Hydrogen	0781-5186	ESS7-200-350	10-200
Acetylene	0781-5187	ESS7-15-510	2-15
L.P. Gas	0781-5188	ESS7-125-510LP	5-125

Outlet Connection 7/8"-14(M) like other regulators

# EDGE ADJUSTING LOCK

Ideal for setting pressures and avoiding tampering by others. Comes with three color decals - red, green, black.

Part No: 0750-0221





# VTS 700

Extra Heavy Duty,  
Two Stage, High Flow

### Design/Construction

- 2.5 in. (63.5 mm) gauges – steel
- Diaphragms – 2 in. (50.8 mm) and 3.25 in. (82.6 mm) – stainless steel



# VTS 250

Medium Duty,  
Two Stage

### Design/Construction

- Delrin Insert Bushing for durability, easier adjusting
- Die-Forged Brass Spring Housing Cap provides greater strength and durability
- Fabric reinforced neoprene diaphragm gives long lasting service
- Stem-Type Seat Mechanism inlet pressure aides in sealing
- Stainless Ball in adjusting screw for easy adjustment
- Die-Forged Brass Body for extra strength
- Precision Machined Nozzle for optimum flow control
- Adjusting Spring designed for precise adjustment



### Additional Features

- External self reseating relief valve – Not designed to protect downstream equipment (no relief valve is needed on low pressure fuel gas models)
- Sintered inlet filter – electroless nickel plated bronze
- Regulators will deliver at least the stated upper range and in some cases may exceed the stated upper range

### VTS 700 Flow Data

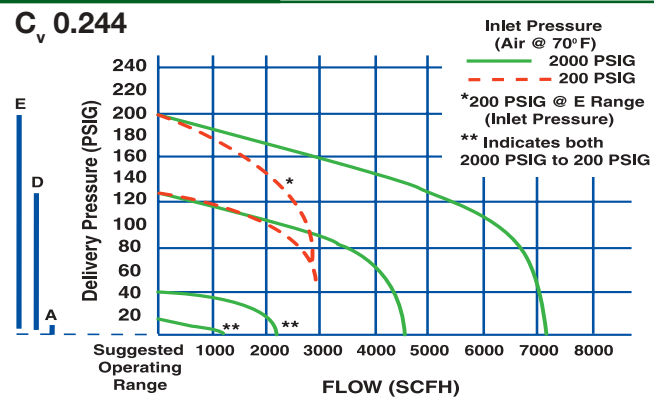

### Specifications

Maximum Inlet	Dimensions L x W x H	Weight
3000 psig	8.63 x 6.75 x 7.5 in. (219 x 171.5 x 190.5 mm)	8 lbs 8 oz (3.86 kg)

### Ordering Information

Gas Service	Part No.	Model No.	Delivery Range (psig)
Oxygen, Inert Gas	0780-0928	VTS 700D-580	5-125
	0780-0939	VTS 700E-540	10-200
	0780-0943	VTS 700E-580	10-200
Acetylene	0780-0984	VTS 710A-510	2-15

Outlet Connections: 7/8"-14(M)

### VTS 250 Flow Data

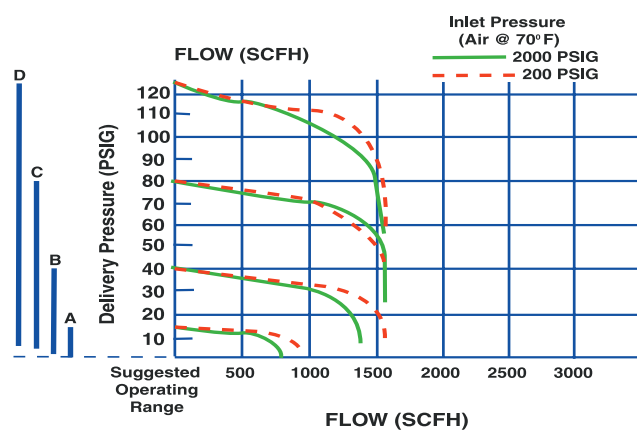

### Ordering Information

Gas Service	Part No.	Model No.	Delivery Range (psig)
Oxygen	0781-3503	VTS250A-540	2-15
	0781-3504	VTS250B-540	2-40
	0781-3505	VTS250C-540	4-80
	0781-3506	VTS250D-540	5-125

Outlet Connections: 9/16"-18 (M RH)



# D1G PILOT-DOMELOAD

Hybrid Regulator

### Design/Construction

- Larger 3/4" NPT Inlet and Outlet ports
- Lighter, more compact design for maximum versatility
- Large, replaceable 50 micron inlet filter for enhanced protection of internal components
- 30,000+ SCFH flow capacity

### Additional Features

- Includes mounting bracket



### Specifications

Maximum Inlet	Gas Service	
3000 psig	Inert Gas, Oxygen, Industrial Air	
Outlet Pressure	Standards Compliance	Flow Coefficient (Cv)
50-550 psig	CGA E-4	1.02
Operating Temperature	0° – 140° F (-17.9 – 60° C)	
Outlet Pressure Rise	1.0 psig per 100 psig Decay	

### Ordering Information

Gas Service	Part No.	Model No.
n/a	0782-4420	D1G-550-580-12F
Inert Gas	0782-4421	D1G-550-580-12F with CGA 580 inlet
Oxygen	0782-4422	D1G-550-540-12F with CGA 540 inlet
Industrial Air	0782-4423	D1G-550-590-12F with CGA 590 inlet

Outlet Connections: 3/4"-14 NPT (F)

### D1G Flow Data

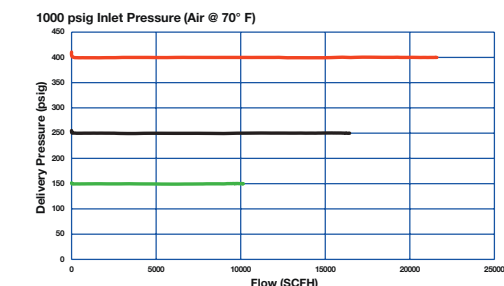
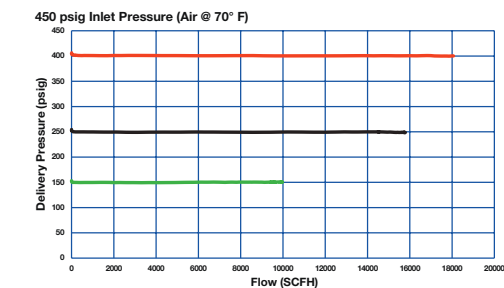



# ETS4 SERIES

High Capacity, Two Stage Design

### Design/Construction

- Forged brass body
- Zinc-aluminum housing caps
- High impact ABS gauge guard
- 1.5 in. UL listed/recognized gauges – brass
- Stem type seat mechanism: urethane seat material – air, oxygen, inerts, CO2, N2O, other high pressure gases; neoprene seat material – low pressure fuel gases
- 2.7 in. fabric reinforced neoprene diaphragm in 2nd stage, 0.75 in. diameter brass piston in 1st stage
- External self reseating relief valve. Not designed to protect downstream equipment (no relief valve is needed on low pressure fuel gas models)
- Sintered inlet filter – nickel plated bronze
- SLAM impact absorbing safety knob
- Meets or exceeds CGA E-4, UL 252 and ASTM G-175 Promoted Ignition Test



### Specifications

<b>Dimensions L x W x H</b>	<b>Weight</b>
4.72 x 6.85 x 4.4 in. (120 x 174 x 111.8 mm)	4 lbs 12 oz (2.15 kg)

### Ordering Information

Gas Service	Part No.	Model No.	Delivery Range (psig)
Air, Oxygen, Inert Gas	0781-5231	ETS4-125-346	5-125
	0781-5232	ETS4-200-346	10-200
	0781-5217	ETS4-40-540	2-40
	0781-5218	ETS4-125-540	5-125
	0781-5219	ETS4-200-540	10-200
	0781-5221	ETS4-40-580	20-40
	0781-5222	ETS4-125-580	5-125
Industrial Air	0781-5223	ETS4-200-580	10-200
	0781-5224	ETS4-125-590	5-125
British Oxygen/Fuel	0785-2120	ETS4-125-992	5-125
	0785-2121	ETS4-200-992	10-200
Hydrogen/Methane	0785-2122	ETS4-15-993	2-15
	0781-5225	ETS4-40-350	2-40
	0781-5226	ETS4-125-350	5-125
Carbon Dioxide	0781-5227	ETS4-200-350	10-200
	0781-5228	ETS4-125-320	5-125
Acetylene	0781-5229	ETS4-15-300	2-15
	0781-5230	ETS4-15-510	2-15

### ETS4 Flow Data

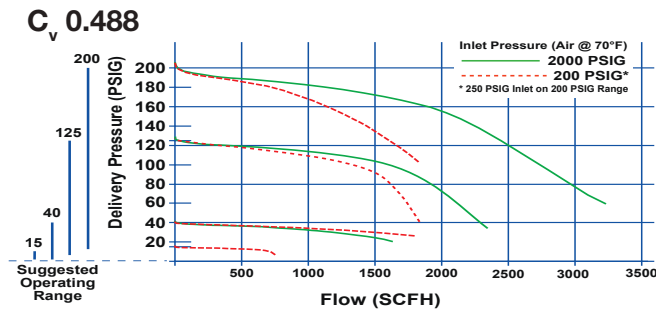

# EHP SERIES

High Pressure

Developed specifically for applications which require higher deliver pressure (400 or 800 PSIG maximum) Provides even higher deliver capability than the SR 600 it's replacing.

### Design/Construction

- Replaces SR 600 series
- Forged brass body
- High strength Zinc-Aluminum house cap
- High impact ABS gauge guard
- Color-coded SLAM impact absorbing safety knob



### EHP High Pressure Flow Data

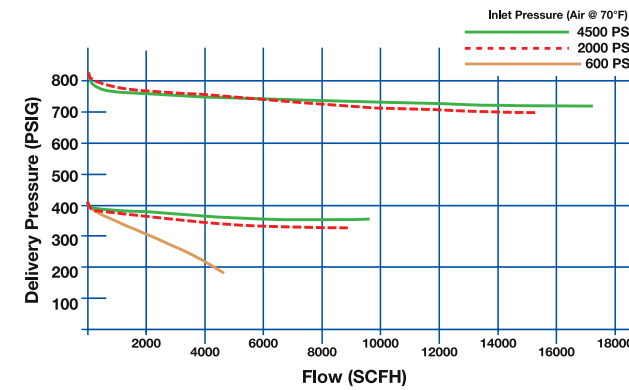

### Specifications

<b>Maximum Inlet</b>	<b>Dimensions L x W x H</b>	<b>Weight</b>
3000 psig	6.25 x 6 x 6.5 in. (158.8 x 152.4 x 165 mm)	4 lbs (1.81 kg)

### Ordering Information

Gas Service	Part No.	Model No.	Delivery Range (psig)
Oxygen	0781-5170	EHP3-800-540	20-800
Inert Gas	0781-5168	EHP3-400-680	20-400
	0781-5171	EHP3-800-580	20-800
Air	0781-5169	EHP3-400-347	20-400

Inlet: \*1/4" NPT(F)  
 Outlet Fitting: 1/4" Swagelok type stainless steel.  
 +5/8"-20 UNF(M) inlet 1/8" NPT(F) outlet

# GT350 SERIES

Heavy Duty, Two Stage I

### Design/Construction

- 2" (50.8 mm) gauges – steel
- Diaphragms – 1.33" (33.8 mm) first stage 2.69" (68.3 mm) second stage fabric reinforced neoprene

### Dimensions

6.79" W x 5.31" H x 6.80" D (172.5 W x 134.9 H x 172.7 D mm)

### Weight

3 lbs 12 oz (1.70 kg)

### Performance

Maximum inlet – 3000 psig



### GT350 Two Stage Flow Data

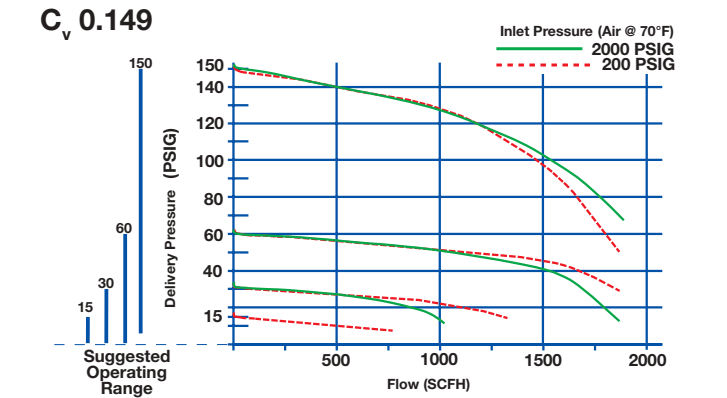

### Ordering Information

Gas Service	Part No.	Model No.	Delivery Range (psig)
Air, Oxygen, Inert Gas	0781-4255	GT350-150-346	5-150
	0781-4260	GT350-60-540	2-60
	0781-4261	GT350-150-540	5-150
	0781-4263	GT350-30-580	2-30
	0781-4264	GT350-60-580	2-60
British Oxygen/Fuel	0781-4265	GT350-150-580	5-150
	0781-4269	GT350-150-992	5-150
Hydrogen/Methane	0781-4270	GT350-15-993	2-15
	0781-4256	GT350-60-350	2-60
Carbon Dioxide	0781-4257	GT350-150-350	5-150
	0781-4253	GT350-60-320	2-60
Acetylene	0781-4254	GT350-150-320	5-150
	0781-4252	GT350-15-300	2-15
L.P. Gas	0781-4258	GT350-15-510	2-15
	0781-4259	GT350-60-510LP	2-60



# SR 4

## High Pressure

Heavy duty, high pressure piston regulator. Ideally suited for pressure vessel and dead-end testing. Delivery pressures up to 4500 psig on some models.

### Design/Construction

- Machined brass body & housing cap
- 2.5 in. (63.5 mm) gauges – brass
- Cartridge type seat assembly with PCTFE seat
- Piston type actuation – brass
- Delrin cap bushing for smooth adjustments
- External adjustable relief valves on F and G range models
- Hydrogen models have ventable relief valves (J Series does not)
- Sintered inlet filter – bronze

### Panel Mounting Details

- All SR 4 Series regulator models may be panel mounted.
- 1.75 in. (44.5 mm) (hole required in panel for mounting).
- For a flush panel mount installation order one panel mount nut 1409-0093. For an adjustable panel mount installation order two panel mount nuts 1409-0093.



Specifications		
Maximum Inlet	Dimensions L x W x H	Weight
7500 psig with CGA 677 6000 psig without inlet fitting 5500 psig with CGA 701, 680, 347 4000 psig with CGA 577 3000 psig with CGA 540, 580, 346, 350	6.25 x 6 x 6.5 in. (158.8 x 152.4 x 165.1 mm)	4 lbs (1.81 kg)

Ordering Information			
Gas Service	Part No.	Model No.	Delivery Range (psig)
Oxygen	0781-1405	SR 4F-540	50-750
	0781-1425	SR 4G-540	100-1500
	0781-1445	SR 4J-540	200-3000
Inert Gas	0781-1408	SR 4F-580	50-750
	0781-1410	SR 4F-680	50-750
	0781-1428	SR 4G-580	100-1500
	0781-1430	SR 4G-680	100-1500
	0781-1448	SR 4J-580	200-3000
	0781-1450	SR 4J-680	200-3000
	0781-1453	SR 4J-677	200-3000
	0781-1470	SR 4K-680	300-4500
Air	0781-1473	SR 4K-677	300-4500
	0781-1403	SR 4F-347	50-750
	0781-1422	SR 4G-346	100-1500
	0781-1442	SR 4J-346	200-3000
Methane, Hydrogen	0781-1463	SR 4K-347	300-4500
	0781-1404	SR 4F-350	50-750
	0781-1424	SR 4G-350	100-1500
CO <sub>2</sub>	0781-1444	SR 4J-350	200-3000
	0781-1401	SR 4F-320	50-750
Panel Mount 1/4" NPT Inlet	0781-1415	*SR 4PF-250	50-750
	0781-1420	*SR 4PG-250	100-1500
	0781-1455	*SR 4PJ-250	200-3000
	0781-1475	+SR 4PK-250	300-4500
Manifold High Pressure	0781-1454	SR 4TJ-996	200-3000

Inlet: \*1/4" NPT(F)  
Outlet Fitting: 1/4" Swagelok type stainless steel.  
+5/8"-20 UNF(M) inlet 1/8" NPT(F) outlet

### SR 4 FLOW DATA

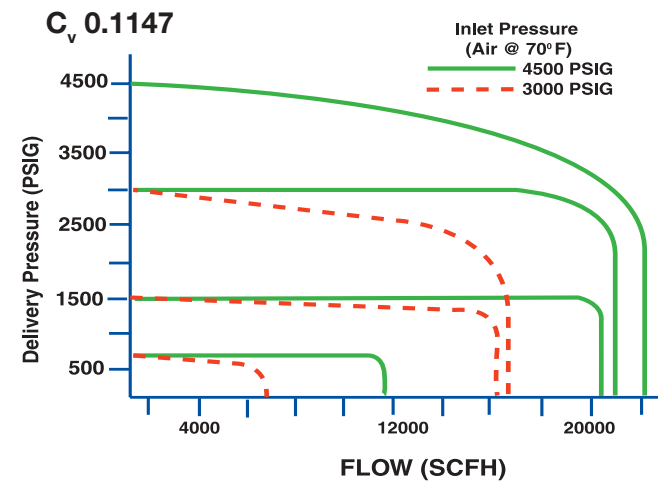

# MANIFOLD REGULATORS

## Heavy Duty

Wide range of flow capabilities  
Wide range of pressure delivery  
Single and two stage models available

### Design/Construction

- Single Stage, Extra Heavy Duty
- 15 psig (Acetylene), 40 psig, 125 psig, 200 psig
- 350 psig Acetylene & LP Gas, 3000 psig HP Models, 350 psig Pipeline Models
- 2.5" UL Listed & Recognized Gauges as Required
- Standard Compliance CGA E-4, UL 252
- Self Reseating Relief Valve (Not Included w/Acetylene, LP Gas)
- Flow Coefficient (Cv) 0.598
- 7.6 lbs Approx. Forged Brass CDA 377 (UNS C37700, CW617N per EN12165)
- Forged Brass CDA 377 (UNS C37700, CW617N per EN12165)
- Type 301 Stainless Steel
- 3000 psig Inlet Models - Urethane
- Low Pressure Fuel Gases (Acetylene, Propane, etc.) - Neoprene
- Type 302 Stainless Steel
- Brass & Stainless Steel Components, PTFE Friction Dampers, Nylon Gaskets

### Ordering Information

Gas Service	Part No.	Model No.	Delivery Range (psig)
<b>HIGH PRESSURE DELIVERY, PISTON</b>			
Air, Oxygen, Inert Gas, Hydrogen	0781-1457	SR 4MF-996	50-750
	0781-1437	SR 4MG-996	100-1500
	0781-1458	SR 4MJ-996	200-3000
	0781-1436	SR 4MF-997	50-750
	0781-1438	SR 4MG-997	100-1500
0781-1456	SR 4MJ-997	200-3000	
<b>SINGLE STAGE</b>			
Air, Oxygen, Inert Gas	0781-0611	SR 450MD-996	5-125
	0781-0612	SR 450ME-996	10-200
Methane, Hydrogen	0781-0613	SR 452MD-997	5-125
CO <sub>2</sub>	0781-0615	SR 453MD-996	5-125
Acetylene	0781-0617	SR 460MA-997	2-15
L.P. Gas	0781-0618	SR 461MB-997	2-40
	0781-0619	SR 461MD-997	5-125
<b>EXTRA HIGH FLOW, SINGLE STAGE</b>			
Air, Oxygen, Inert Gas	0780-0797	SR 700MD-996	5-125
	0780-0798	SR 700ME-996	10-200
	0780-0809	SR 700MD-500	5-125
Methane, Hydrogen	0780-0803	SR 702ME-997	10-200
CO <sub>2</sub>	0780-0804	SR 703MD-996	5-125
CO <sub>2</sub>	0780-0805	SR 703ME-996	10-200
Acetylene	0780-0806	SR 710MA-997	2-15
L.P. Gas	0780-0807	SR 711MB-997	2-40
<b>TWO STAGE</b>			
Methane, Hydrogen	0781-3961	VTS 452MD-997	5-125
	0781-3962	VTS 452ME-997	10-200
<b>TWO STAGE, HIGH FLOW</b>			
Air, Oxygen, Inert Gas	0780-0997	VTS 700MD-996	5-125
	0780-0998	VTS 700ME-996	10-200
CO <sub>2</sub>	0780-1004	VTS 703MD-996	5-125
	0780-1005	VTS 703ME-996	10-200
Acetylene	0780-1006	VTS 710MA-997	2-15
L.P. Gas	0780-1007	VTS 711MB-997	2-40

Inlet Connection: 1"-11.5 NPS(M)  
Outlet Connections: 1"-11.5 NPS(F)



### R700/HPL700 FLOW DATA

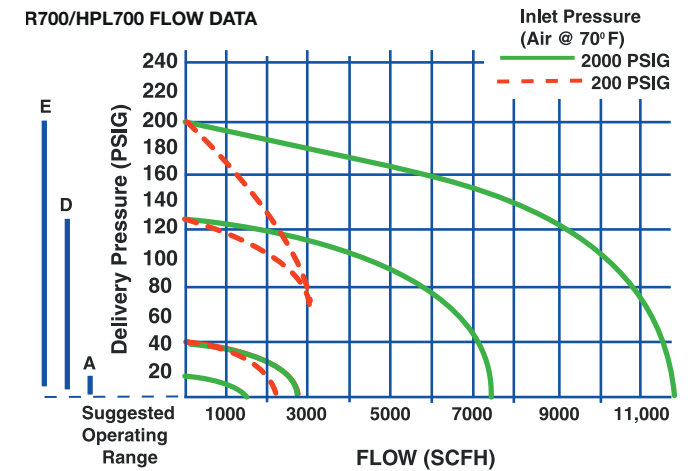



# ELC4

Liquid Cylinder

### Design/Construction

- Stainless diaphragm
- Rear entry design



# ESL4

Line Regulator

### Design/Construction

- Versatile – supports a variety of inlet pressures (up to 3000 psig)



# EST4

Station Regulator

### Design/Construction

- Side entry and rear entry inlet versions available



# L 700

High Flow Regulator

### Design/Construction

- Forged brass body & housing cap
- 2.5" (63.5 mm) gauge – brass
- Stem type seat mechanism
- 3.25" (82.6 mm) diaphragm – fabric-reinforced neoprene
- Delrin cap bushing for smooth adjustments
- Designed for gas distribution system (pipeline)
- Available in either 1/2" NPT(F) or 3/4" NPT(F) inlet



GAS CONTROL

GAS CONTROL

## ELC4 Flow Data - EDGE Series-Liquid Cylinder

C<sub>v</sub> 0.488

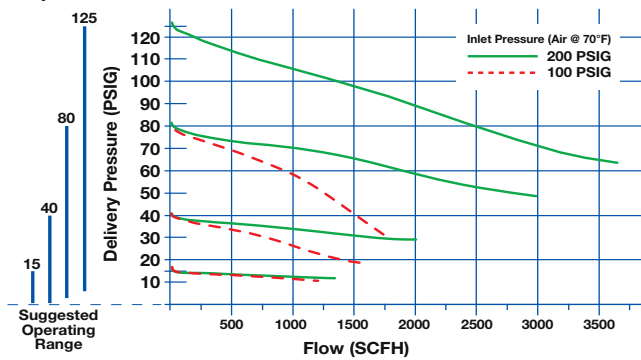

## ESL4 Flow Data - EDGE Series-Line

C<sub>v</sub> 0.488

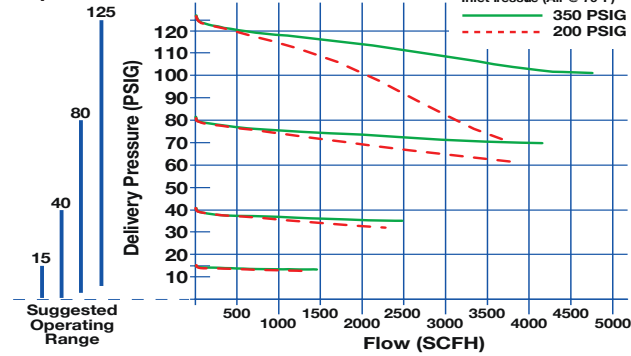

## EST4 Flow Data - EDGE Series-Station

C<sub>v</sub> 0.178

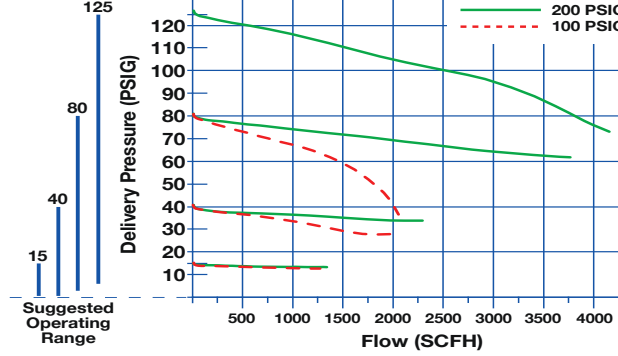

## L 700 Flow Data

C<sub>v</sub> 1.77

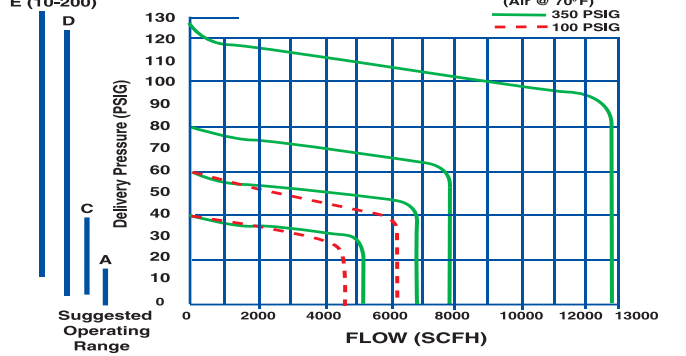

### Specifications

Maximum Inlet	Dimensions L x W x H	Weight
3000 psig	8.2 x 3.8 x 7 in. (208.3 x 96.5 x 180.3 mm)	4 lbs 5 oz (1.95 kg)

### Ordering Information

Gas Service	Part No.	Model No.	Delivery Range (psig)
Oxygen	0781-5199	ELC4-125-540R	5-125
Inert (Nitrogen, Argon, Helium)	0781-5200	ELC4-125-580R	5-125
	0781-5202	ELC4-325-580R	5-325
Carbon Dioxide	0781-5201	ELC4-125-320R	5-125

### Specifications

Maximum Inlet	Dimensions L x W x H	Weight
3000 psig	8.2 x 3.8 x 7 in. (208.3 x 96.5 x 180.3 mm)	4 lbs 5 oz (1.95 kg)

### Ordering Information

Gas Service	Part No.	Model No.	Delivery Range (psig)
Air, Inert Gas, Carbon Dioxide, Nitrous Oxide	0781-5190	ESL4-125-250	5-125
Oxygen	0781-5214	ESL4-125-250X	5-125
Hydrogen, Methane, Natural Gas, L.P. Gas	0781-5210	ESL4-80-250F	4-80
	0781-5211	ESL4-125-250F	5-125
Acetylene	0781-5208	ESL4-15-250A	2-15

### Specifications

Maximum Inlet	Dimensions L x W x H	Weight
3000 psig	8.2 x 3.8 x 7 in. (208.3 x 96.5 x 180.3 mm)	4 lbs 5 oz (1.95 kg)

### Ordering Information

Gas Service	Part No.	Model No.	Delivery Range (psig)
Oxygen	0781-5191	EST4-40-024	2-40
	0781-5204	EST4-40-024R	2-40
	0781-5192	EST4-80-024	4-80
	0781-5205	EST4-80-024R	4-80
	0781-5193	EST4-125-024	5-125
	0781-5206	EST4-125-024R	5-125
Inert (Nitrogen, Argon, Helium)	0781-5189	EST4-125-034	5-125
	0781-5207	EST4-125-034R	5-125
Acetylene	0781-5194	EST4-15-025	2-15
	0781-5209	EST4-15-025R	2-15
Hydrogen, Methane, Natural Gas, L.P. Gas	0781-5195	EST4-80-025	4-80
	0781-5212	EST4-80-025R	4-80
	0781-5196	EST4-125-025	5-125
	0781-5213	EST4-125-025R	5-125

**WARNING:** Maximum inlet pressure 350 psig. Not for use on cylinders.

### Specifications

Maximum Inlet	Dimensions L x W x H	Weight
350 psig	6 x 4 x 7 in. (152.4 x 101.6 x 177.8 mm)	4 lbs 15 oz (2.4 kg)

### Ordering Information

Gas Service	Part No.	Model No.	Delivery Range (psig)	Inlet & Outlet Ports
Air, Oxygen, Inert Gas	0780-1229	L 700C-500	4-80	1/2" NPT(F)
	0780-1220	L 700C-750	4-80	3/4" NPT(F)
	0780-1207	L 700D-500	5-125	1/2" NPT(F)
	0780-1236	L 700D-500 PMT*	5-125	1/2" NPT(F)
	0780-1209	L 700D-750	5-125	3/4" NPT(F)
	0780-1221	L 700E-500	10-200	1/2" NPT(F)
Acetylene	0780-1222	L 700E-750	10-200	3/4" NPT(F)
	0780-1233	L 710A-500	2-15	1/2" NPT(F)
Hydrogen, L.P. Gas	0780-1201	L 710A-750	2-15	3/4" NPT(F)
	0780-1199	L 711D-500	5-125	1/2" NPT(F)

\*PMT Panel Mount



# SLR 150

Surge Limiting Regulator  
(for use with Shielding Gas)

### Design/Construction

- Reduces gas surge at the application of the torch/gun
- Provides a more consistent flow rate of shielding gas to welding machine
- Forged brass body & high strength alloy housing cap
- Neoprene diaphragm
- 50 micron sintered bronze internal filter

### Performance

- Recommended inlet pressure: 100± 20 psig (200 max)
- Flow: 50 SCFH (preset)
- Connections: CGA 032 RH

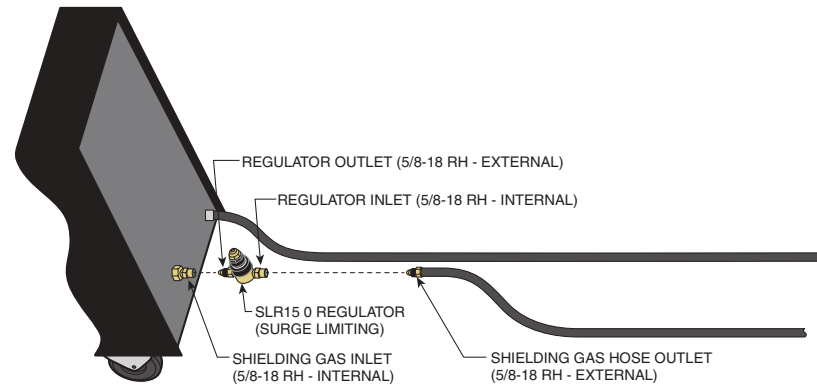

### Ordering Information

Gas Service	Part No.	Model No.	CGA Inlet Connection
Inert Gas	0781-1207	SLR 150	032

Outlet Connections: Inlet 5/8" - 18 RH(F)  
Outlet 5/8" - 18 RH(M)

## What Does Back Pressure Compensation Mean?

When a flow meter is back pressure compensated, it is not affected by any downstream restrictions that result in a pressure buildup. In a device that is not compensated, the back pressure will result in inaccurate readings on the flow tube or gauge.

All Victor FM Series flow meters are back pressure compensated to ensure accurate reading at all times, even if line restrictions are present.

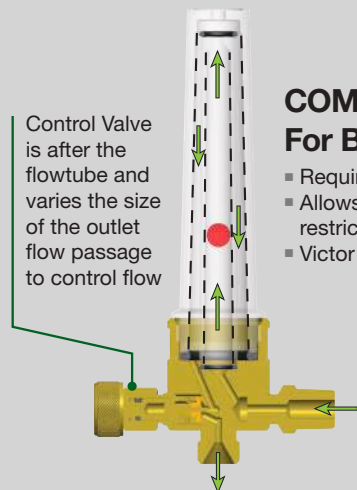

### COMPENSATED For Back Pressure

- Requires constant inlet pressure
- Allows for varying downstream restrictions
- Victor flow meters are of this type

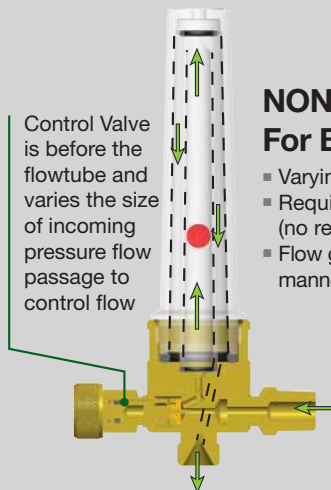

### NON-COMPENSATED For Back Pressure

- Varying inlet pressures tolerable
- Requires flowing to atmosphere (no restrictions) to be accurate
- Flow gauge regulators operate in this manner

# ESS32 PFH-800

Pressure/Flow Hybrid Regulator

### Design/Construction

- Nitrogen CGA-580 tool-less connection
- Fully enclosed, highly visible modular gauges for optimum clarity with robust metal gauge guard for maximum protection
- SLAM™ (Shock Limitation and Absorption Mechanism) technology built into the adjusting knob, provides additional strength, safety and protection of the regulator
- Up to 800 psi testing pressure



### ESS3-PFH-800 Flow Data

ESS32-PFH-800 Flow Performance - Micro View BRAZE and PURGE ranges

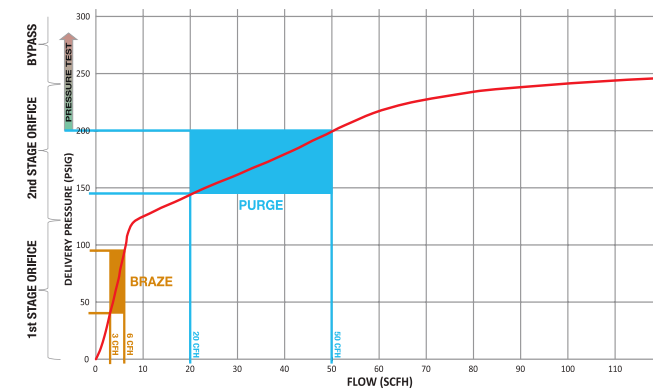

### Specifications

Maximum Inlet	Outlet Connection	Gas Service
3000 psig	1/4 in. SAE Flare	Nitrogen

### Controlled Pressure and Flow

- 3 – 6 CFH (BRAZE)
- 20 – 50 CFH (PURGE)
- 200 – 800 PSIG (PRESSURE TEST)

### Operating Temperature

0° – 120° F (-17.9 – 48.9° C)

### Storage Temperature

-20° – 140° F (-28.9 – 60° C)

### Ordering Information

ESS32-PFH-580 Pressure-Flow Hybrid Regulator 0781-3652

# SR 310/311/312

Flowmeter

### Design/Construction

- Designed for CO<sub>2</sub> application (non-siphoned tube cylinders)
- High flow CO<sub>2</sub> applications (SR 310 100 psig) with adequate supply or source
- Designed for core wire applications
- Machined aluminum body & housing cap
- 2 in. (50.8 mm) gauge
- Stem type seat mechanism
- 1.75 in. (44.5 mm) diaphragm – fabric reinforced neoprene
- Self reseating relief valve (not designed to protect downstream equipment)
- Sintered inlet filter – bronze



A regulator equipped with a flow gauge is not accurate when a back pressure in excess of 2 psig exists at the outlet. Back pressure is caused by a restriction in the equipment downstream of the flow gauge. Metering valves, kinked hoses or even very long hoses are restrictions that can cause back pressure. In applications where back pressure in excess of 2 psig can be expected, a regulator equipped with a flowmeter should be used.

**WARNING:** High gas withdrawal rates may cause regulator freeze up and will require cylinder manifolding. Consult your gas supplier. See below for Gas Heater.

### Specifications

Maximum Inlet	Delivery Range
1500 psig	100 SCFH
Dimensions L x W x H	Weight
2.5 x 8.38 x 7.25 in. (63.5 x 212.9 x 184.2 mm)	2 lbs 15 oz (1.33 kg)

### Ordering Information

Model	Diameter	Part No.
SR 310 Adjustable Pressure Gauge	2 in. (50.8 mm)	0781-0355
SR 311 (Preset @ 80 psig) Flowmeter	2 in. (50.8 mm)	0781-0353
SR 312 Flow Gauge	2 in. (50.8 mm)	0781-0354



# FLOWMETER

## Heavy Duty

### Design/Construction

- Gas flow measurement in SCFH
- MIG / TIG applications
- Flowtube and outer tube are made of impact resistant lexan for severe applications
- Pressure compensated for low surge requirement
- Cover tube contains overpressure protection

All Victor flowmeters are back pressure compensated to ensure accurate readings at all times, even if line restrictions are present. All flowmeters are calibrated to operate at 25 psig inlet pressure to minimize surge, except the FM 200 which is calibrated to operate at 80 psig.



FM372

Ordering Information						
Part No.	Model No.	Flow Range (SCFH)	Inlet Fitting	Outlet Fitting	Replacement Flow Tube	Inlet Pressure (psig)
<b>Units with single gas calibration</b>						
1000-0264	FM 200	30-100 CO <sub>2</sub>	1/4" NPT(M)	5/8"-18 RH(F)	1015-0066	80
<b>Units with 2 gas calibrations</b>						
1000-0268	FM 150	10-60 Air, 10-60 Nitrogen	1/4" NPT(M)	5/8"-18 RH(F)	1015-0060	25
1000-0255	FM 135	4-18 Argon, 10-50 Helium	9/16"-18 RH(F)	5/8"-18 RH(F)	1015-0063	25
1000-0256	FM 145	4-18 Argon, 10-50 Helium	5/8"-18 RH(M)	5/8"-18 RH(F)	1015-0063	25
1000-0257	FM 155	4-18 Argon, 10-50 Helium	1/4" NPT(M)	5/8"-18 RH(F)	1015-0063	25
1000-0261	FM 137	15-65 Argon, 40-200 Helium	9/16"-18 RH(F)	5/8"-18 RH(F)	1015-0064	25
1000-0262	FM 147	15-70 Argon, 40-200 Helium	5/8"-18 RH(M)	5/8"-18 RH(F)	1015-0064	25
1000-0263	FM 157	15-65 Argon, 40-200 Helium	1/4" NPT(M)	5/8"-18 RH(F)	1015-0064	25
<b>Units with 3 gas calibrations</b>						
1000-0258	FM 370	5-40 CO <sub>2</sub> , 5-50 Argon, 20-150 Helium	9/16"-18 RH(F)	5/8"-18 RH(F)	1015-0057	25
1000-0259	FM 371	5-40 CO <sub>2</sub> , 5-50 Argon, 20-150 Helium	5/8"-18 RH(M)	5/8"-18 RH(F)	1015-0057	25
1000-0182	FM 372	5-40 CO <sub>2</sub> , 5-50 Argon, 20-150 Helium	1/4" NPT(M)	5/8"-18 RH(F)	1015-0057	25

**WARNING:** Not designed for cylinder use. Do not exceed calibrated inlet pressure.

To ensure proper gas flow and to prevent tampering to your flowmeter use a Victor Locking Valve (Part No. 0662-0079).

# HRF 2400 PRO

## Medium Duty, Flowmeter

### Performance

- 70 CFH Flow Rate to support MIG / TIG and other high flow applications
- Ideal for all applications where superior dependability is needed
- Newly designed flow tube with improved scale visibility
- Superior CO<sub>2</sub> performance for longer CO<sub>2</sub> application run time
- Accurate, consistent flow delivery over the life of the cylinder

### Design

- Regulator / flowmeter combination in one compact unit
- Diaphragm style regulator with fabric reinforced neoprene diaphragm
- Back pressure compensated
- Precision needle valve, ensuring an accurate flow rate, even when exceeding 50 CFH
- External self-seating pressure relief valve (not designed to protect downstream equipment)
- Safety overpressure burst mechanism built into flow tube for added safety
- Machined brass body & die cast housing cap
- Sintered inlet filter – bronze
- Third-party ETL listed to UL Standard 252



### Specifications

Maximum Inlet	Outlet Pressure
3000 psig (CGA 580, CGA 320, 992 Models) 200 psig (CGA 032, CGA 034 Models)	Preset
Dimensions L x W x H	Weight
3 x 5.63 x 8.25 in. (76.2 x 143 x 209.6 mm)	2 lbs 8 oz (1.13 kg)

**WARNING:** High gas withdrawal rates on carbon dioxide may require cylinder manifolding. Consult your gas supplier.

### Ordering Information

Gas Service	Part No.	Model No.	Flow Range (CFH)	Specify CGA Inlet Connection	Replacement Flow Tube
Argon, Argon/Carbon Dioxide Mix	0781-3656	HRF2435P-580	0-70 (Argon), 0-70 (CO <sub>2</sub> )	580	1015-0080
	0781-3657	HRF2435P-580 with 10 ft (3.1 m) hose			1015-0080
	0781-3658	HRF2435P-580 with hose barb			1015-0080
	0781-3661	HRF2480P-992			1015-0081
	0781-3662	HRF2435P-034 (Pipeline)			1015-0081
	0781-3663	HRF2435P-032 (Pipeline)			1015-0081
Carbon Dioxide, Carbon Dioxide Mix	0781-3659	HRF2480P-320	0-70 (CO <sub>2</sub> ), 0-70 (Argon)	320	1015-0080
	0781-3660	HRF2480P-320 with 10 ft (3.1 m) hose			1015-0080
Helium	0781-3664	HRF2435-580 HEL	0-200 (Helium)	580	1015-0064

Outlet Connections: 5/8"-18 RH(F), CGA 032

# DFM 150

## Medium Duty

### Design/Construction

- Designed to monitor two separate processes or gas flows
- Ideal for applications where shielding gas and back purge requirements are needed
- Designed to offer convenience for the maintenance and fabrication industries
- Brass body

- Teflon seat mechanism
- Sintered inlet filter – bronze
- Music wire – spring
- Piston – brass
- Cover tube – lexan



### Specifications

Maximum Inlet	Outlet Pressure
3000 psig	25 psig (preset)
Dimensions L x W x H	Weight
5 x 5.5 x 6.5 in. (127 x 139.7 x 165.1 mm)	2 lbs 9 oz (1.16 kg)

### Ordering Information

Gas Service	Part No.	Model No.	Flow Range (SCFH)	CGA Inlet Connection	Max Inlet (psig)	HP Gauge	Replacement Flow Tube
Argon, Helium	0781-1153	DFM 150-580	5-50 (Argon), 20-150 (Helium)	580	3000	0-4000	1015-0057
Argon, Argon / Carbon Dioxide, Helium Low Pressure	0781-1206	DFM 150S	5-50 (Argon), 5-40 (Argon/CO <sub>2</sub> ) 20-150 (Helium)	1/4" NPT (F)	75	0-100	1015-0057

Outlet Connection: 5/8"-18 RH(F), CGA 032, Preset Pressure: 25 psig



# HSR & HVTS

Medium Duty, Flowmeter



HSR Series

HVTS Series

## HSR Models (Single Stage)

### Design/Construction

- Single or two stage design
- Compact in size
- Accurate regulator for gas flow
- MIG / TIG applications
- Two stage version provides extremely accurate flow rates as cylinder pressure declines
- Low surge rates – 25 psi preset

## HVTS Models (Two Stage)

### Design/Construction

- Forged brass body and housing cap
- 2 in. (50.8 mm) high pressure gauge
- Stem type seat mechanism
- Fabric reinforced neoprene diaphragm
- External self reseating relief valve (not designed to protect downstream equipment)
- Sintered inlet filter – bronze

Specifications				
Model	Maximum Inlet	Outlet Pressure	Dimensions L x W x H	Weight
HSR	3000 psig	25 psig (preset), 80 psig on CO2	4.25 x 7 x 6.25 in. (108 x 177.8 x 158.8 mm)	3 lbs 3 oz (1.45 kg)
HVTS	3000 psig	25 psig (preset), 80 psig on CO2	6.5 x 7 x 5.5 in. (165 x 177.8 x 139.7 mm)	4 lbs 10 oz (2.1 kg)

Ordering Information						
Gas Service	Part No.	Model No.	Flow Range (SCFH)	Specify CGA Inlet Connection	Replacement Flow Tube	Gas Calibrations
Nitrogen/Air	0781-3819	*HSR 2530	10-60	580	1015-0070	2
	0781-3867	*HSR 2535	4-18 / 10-50	580	-	2
Argon/Helium	0781-3775	*HVTS 2535	4-18 / 10-50	580	-	2
	0781-3871	*HSR 2537	15-65 / 40-200	580	1015-0064	2
	0781-3772	*HVTS 2537	15-65 / 40-200	580	1015-0064	2
	0781-3873	*HSR 2570	5-50	580	1015-0057	3
Argon, Argon/Carbon Dioxide Mix, Helium	0781-3869	*HSR 2570	5-40	580	1015-0057	3
	0781-3774	*HVTS 2570	20-150	580	1015-0057	3
Hydrogen	0781-3825	HSR 2533	5-40	350	1015-0070	2
Argon, Argon/Carbon Dioxide, Helium (Max Inlet – 200 psig)	0781-1245	S2570	5-50, 5-40, 20-140	034	1015-0057	3
Inert	0781-3880	HSR 1470-680	50-140-40	680	1015-0057	AR-HE-CO2

\*Outlet Connections: 5/8"-18 RH(F)

**WARNING:** High gas withdrawal rates on carbon dioxide may require cylinder manifolding. Consult your gas supplier.

# GRF 400

Light Duty, Flowmeter



### Design/Construction

- Regulator / Flowmeter
- Single stage piston design
- Argon, Argon/CO<sub>2</sub> mix & CO<sub>2</sub> models
- 25 psig or 80 psig pre-set pressure
- Up to 50 CFH for Argon and up to 38 CFH for CO<sub>2</sub> delivery
- Available in CGA 320 & 580 inlet connections
- Optional MIG kit available with 10 ft (3.1 m) hose

Specifications	
Maximum Inlet	Outlet Pressure
3000 psig	Preset
Dimensions L x W x H	Weight
6.25 x 6 x 6.5 in. (158.8 x 152.4 x 165 mm)	2 lbs (0.91 kg)

Ordering Information	
0781-2701	GRF400-580
0781-2702	GRF400-580 with 10 ft (3.1 m) hose
0781-2703	GRF400-320
0781-2704	GRF400-320 with 10 ft (3.1 m) hose

Outlet Connection: CGA 032



Specifications	
Maximum Inlet	Weight
5500 psig	4 lbs 9 oz (2.2 kg)

# TPR 250 PURGING REGULATOR

Light Duty



### Design/Construction

- Single stage design
- Forged brass body and housing cap
- 2 in. (50.8 mm) gauges
- Stem type seat mechanism
- Neoprene diaphragm

Specifications		
Maximum Inlet	Dimensions L x W x H	Weight
3000 psig	4.25 x 6.38 x 5.1 in. (108 x 162 x 130.3 mm)	2 lbs 15 oz (1.33 kg)

Ordering Information		
Part No.	Model No.	Delivery Pressure (psig)
0781-9133	TPR 250-125-580 CS	5-125
0781-9127	TPR 250-125-320	5-125
0781-9134	TPR 250-200-580 CS	10-250
0781-9135	TPR 250-500-580 CS	10-250

Outlet Connection: 1/4"-37° flare. CS = Clamshell Package

# MECO HIGH PRESSURE

### Design/Construction

- Single-stage design
- Heavy duty applications such as oil/gas industry
- Stainless steel diaphragm
- Positive pressure yoke type regulator
- Multi-seat 4 way seat block
- Available as a preset model or with adjusting T-screw

Ordering Information				
Part No.	Description	Adjusting Mechanism	Pressure	Inlet
5641-8461	P Regulator 125 psi	Cap nut	125	1/4 -18 NPT
5641-8464	P Regulator 150 psi	T screw	150	1/4 -18 NPT
5641-8465	P Regulator 150 psi	Cap nut	150	1/4 -18 NPT
5641-8470	P Regulator 225 psi	T screw	225	1/4 -18 NPT
5641-8468	P Regulator 225 psi	T screw	225	1/4 -18 NPT





### Handles & Cutting Attachments

Design and Construction Features

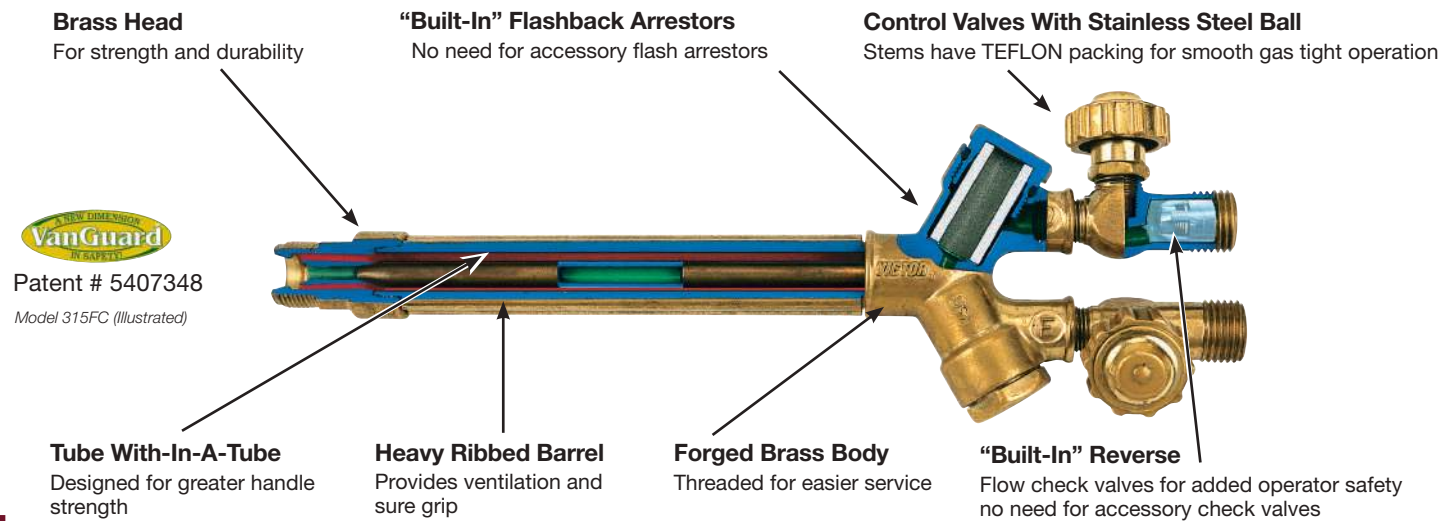

**VanGuard**  
Patent # 5407348  
Model 315FC (Illustrated)

## 300 SERIES HD 310C TORCH HANDLE

Victor Heavy Industry

Built tough to withstand rugged job site conditions. Threaded assembly permits economical repair if service is necessary. The HD 310C has "B" hose connections with built-in reverse flow check valves for added safety.

The HD 310C is compatible with high capacity heating nozzles and all Victor 300 Series equipment.

#### Welding & Cutting Equipment:

- MFA & MFN heating nozzles
- Type 55 high capacity heating nozzles
- CA 2460 cutting attachment
- W Series welding nozzles



#### WARNING: USE FLASHBACK ARRESTORS

Although built to Victor's quality and safety standards, due to the flow capacity requirements, flashback arrestors are not manufactured into this Victor heavy industry torch handle. To reduce the risk of personal injury, death and/or property damage, use sufficient capacity flashback arrestors with all Victor heavy industry torch products.

#### Recommended For Best Performance:

##### Flashback Arrestors

Part No.	Model	Type
<b>Oxygen: (Select one of the following)</b>		
0657-0010	*FB-0	Torch Mount
0657-0014	FB-OR	Regulator Mount
<b>Fuel: (Select one of the following)</b>		
0657-0011	*FB-F	Torch Mount
0657-0015	FB-FR	Regulator Mount
<b>Pair Packs</b>		
0656-0001	*FB-1	Oxy/Fuel Torch Mount
0656-0004	FBR-1	Oxy/Fuel Regulator Mount

\*Torch mount models also protect the hose.

### RUGGED, EFFICIENT DESIGN - THREADED ASSEMBLY FOR EASE OF SERVICE

#### VICTOR TORCH HANDLES GIVE YOU TWICE THE VALUE

Each torch handle is designed and built to withstand rugged job site conditions. In case of damage, Victor's threaded assembly design lets you replace parts quickly and economically.

#### PERFORMANCE PROVEN TUBE-WITHIN-A-TUBE DESIGN

Victor torch handles include one oxygen tube within a massive, heavy ribbed handle which also serves as the gas tube. The result is greater strength and durability plus a reduction in overall size and weight for ease of operation.

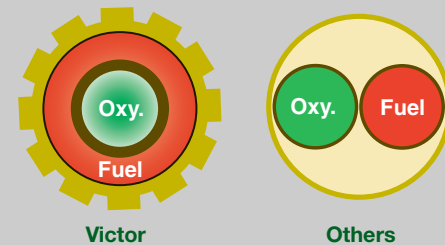
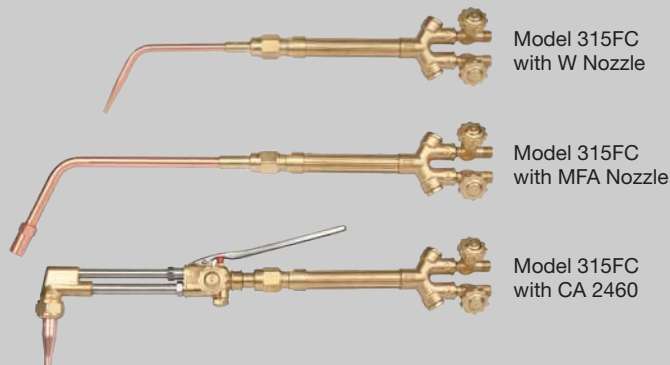

#### VICTOR TUBE-WITHIN-A-TUBE DESIGN

Victor torch handles have greater wall thickness than other designs.

#### Compact Balanced Attachments:

For cutting or heating. Each torch handle is designed for optimal balance and feel with its own nozzles and attachments. With proper balance of length and weight, operator fatigue is minimized.

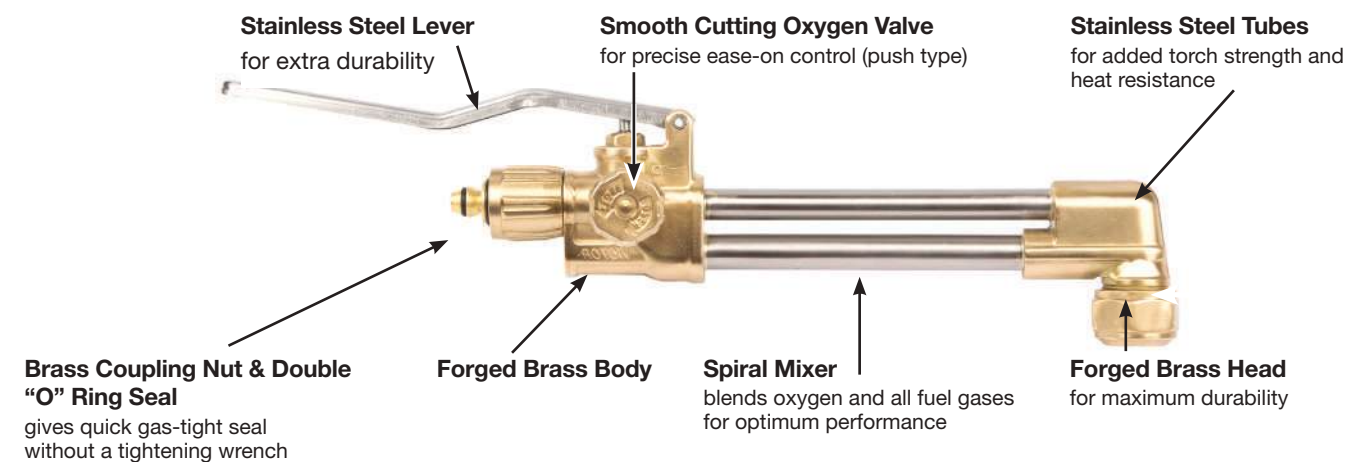

## 300 SERIES WH 315FC+ TORCH HANDLE

Heavy Duty



- Improved head durability, preheat control valve flow and reduced user fatigue due to improved balance
- Improved access and reparability of mixer with single nut removal
- No wrench flats on connection nut indicates hand tightening only for safer operation
- Internal connection snap ring prevents coupling nut sliding and exposure to o-rings for reduced damage
- Use with CA 2460+ cutting attachment

#### Ordering Information

WH 315FC+ Welding Handle 0382-0093

VanGuard torch handles are offered in extra heavy duty (H 315FC) and medium duty (100FC) models, and available in Victor's most popular system models. VanGuard torch handles also feature Victor traditional threaded assemblies for economical repair if service is necessary.

## 100 SERIES 100FC TORCH HANDLE

Medium Duty



#### Victor torch handles are available with VanGuard™ safety features:

- Built-in flashback arrestors – no need for accessory flashback arrestors
- Built-in reverse flow check valves – no need for accessory check valves
- Works with all fuel gases (pressure restrictions for different gases)

#### Ordering Information

Part No.	Description	Hose Connection	Gas	Weight	Length
0382-0032	"VanGuard" Medium Duty	9/16"-18	All	14 oz	8.5 in. (215.9 mm)
0387-0011	"VanGuard" Medium Duty (Clamshell)	9/16"-18	All	14 oz	8.5 in. (215.9 mm)



# J SERIES J-40 & J-28 TORCH HANDLES

Light Duty

Victor torch handles cover the full range of welding, cutting and heating needs. Choose from patented standard models. Performance matched cutting attachments are available for each torch handle series.

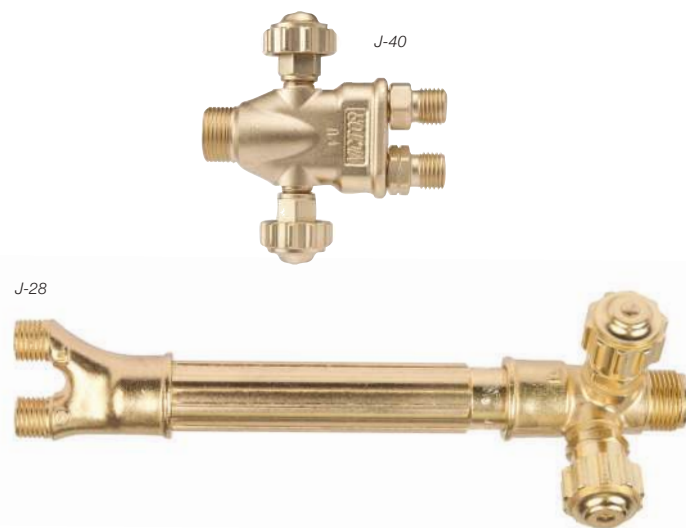

Ordering Information						
Part No.	Model No.	Description	Hose Connection	Gas	Weight	Length
0382-0006	J-40	Standard, Light Duty	"A" Hose CGA 021/022	All	5.5 oz	3.75 in. (95.3 mm)
0382-0127	J-28	Light Duty	"A" Hose CGA 021/022	All	8.5 oz	6 in. (152.4 mm)

J-40 handle does not have check valves or flashback arrestors included. J-28 handle includes accessory reverse flow check valves for regulator use

# CA 2460+ CUTTING ATTACHMENT

Heavy Duty



- Improved head durability, preheat control valve flow and reduced user fatigue due to improved balance
- Improved access and reparability of mixer with single nut removal
- Superior cutting oxygen valve with improved Feathering/Ease-On control
- No wrench flats on connection nut indicates hand tightening only for safer operation
- Internal connection snap ring prevents coupling nut sliding and exposure to o-rings for reduced damage
- Use with WH 315FC+ torch handle

Ordering Information		
CA 2460+ Cutting Attachment, 90 Deg		0381-1928
CA 2460+ Cutting Attachment, 75 Deg		0381-1930
CA 2460+ Cutting Attachment, 180 Deg		0381-1932
Plus Torch Replacement Pack - WH 315FC+/CA 2460+ 90 deg		0381-1937

# CA 1350 CUTTING ATTACHMENT

Medium Duty



Performance matched for each torch handle series.

- Forged brass head
- Spiral mixer blends oxygen and fuel
- Smooth cutting valve (pull type)
- Stainless steel tubes
- Brass coupling nut and double "O" ring seal gives quick gas-tight seal tightening with out wrench
- Length 8 in. (203.2 mm)
- Weight 13 oz (0.37 kg)

Ordering Information				
Part No.	Model No.	Cutting Range	Tip Series	Head Angle
0381-0418	CA 1350	6 in. (152.4 mm)	3	90°
0387-0005	CA 1350 CS	6 in. (152.4 mm)	3	90°
0381-0420	CA 1351	6 in. (152.4 mm)	3	75°
0381-0421	CA 1352	6 in. (152.4 mm)	3	180°

CS = Clamshell Package

# CA 1260 CUTTING ATTACHMENT

Light Duty



(for use with all fuel gases with appropriate tip)

Performance matched for each torch handle series.

- Forged brass head
- Spiral mixer blends oxygen & fuel
- Smooth cutting valve (pull type)
- Stainless steel tubes
- Brass coupling nut & double "O" ring seal gives quick gas-tight seal tightening without wrench
- Length 8 in. (203.2 mm)
- Weight 13 oz (0.37 kg)

Ordering Information				
Part No.	Model No.	Cutting Range	Tip Series	Head Angle
0381-0162	CA 1260	3 in. (76.2 mm)	3	90°
0387-0003	CA 1260 CS	3 in. (76.2 mm)	3	90°

CS = Clamshell Package

# CA370-V/CA 270-V CUTTING ATTACHMENT

Medium Duty



- Forged brass head for durability
- 90 deg. head angle
- One cutting attachment for use with all gases (with proper tip)
- CA 370-V fits WH 370 / CA 270-V fits WH 270

Ordering Information				
Part No.	Model No.	Cutting Range	Tip Series	Head Angle
0387-2650	CA 370-V Single	5 in. (127 mm)	1	90°
0387-2600	CA 270-V Single	5 in. (127 mm)	3	90°
0387-0206	CA 370-V / WH370 Combo	6 in. (152 mm)	1	90°
0387-0200	CA 270-V / WH270 Combo	6 in. (152 mm)	3	90°

# WH370/WH270 TORCH HANDLE

Medium Duty



- Forged brass body for durability
- Torch handle has built-in check valves and flashback arrestors for safety
- WH 370 fits CA 370-V / WH 270 fits CA 270-V

Ordering Information			
Part No.	Model No.	Hose Connection	Gas
0387-2750	WH370 Single	"B" 9/16"-18 (CGA 022 & 023)	All
0387-2700	WH270 Single	"B" 9/16"-18 (CGA 022 & 023)	All

# CA 411-1 CUTTING ATTACHMENT

Heavy Duty



(for use with all fuel gases)

# CA 411-3 CUTTING ATTACHMENT

Medium Duty



(for use with all fuel gases with appropriate tip)

Performance matched for each torch handle series.

- Efficient Universal Spiral Head Mixer
- 1 Cutting Attachment for All Fuel Gases
- Redesigned inlet nut increases grip for Hand Tightening
- In-line stainless tubes for better visibility
- Improved Stainless Lever provides increased comfort and reduced operator hand fatigue
- 5 Year Warranty

Ordering Information				
Part No.	Model No.	Cutting Range	Tip Series	Head Angle
0381-1940	CA411-1	6 in. (152.4 mm)	1	90°
0381-1939	CA411-3	5 in. (127.0 mm)	3	90°

Heavy and medium duty cutting attachments for use with acetylene, propane, butane, liquid air fuel gas, natural gas (2 PSI & above) and propylene. Cutting attachment accepts all Victor Style Tips.

# 400 SERIES WH 411C TORCH HANDLE

Heavy Duty

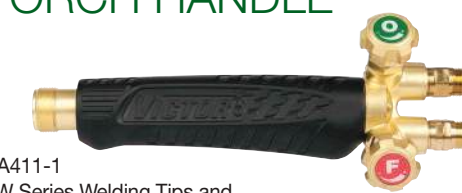

- Accepts CA411-3 & CA411-1 Cutting Attachments, W Series Welding Tips and MFA/MFN/Type55 Heating Assemblies
- 5 Year Warranty

Special designed alloy material:

- 3x the tensile strength of Brass
- Ergonomic, textured, precision contoured handle is designed to reduce operator fatigue and provide better grip
- Durable to withstand tough use and prevention of dents and scratches

Intuitive knobs:

- Color-coded
- Clearly marked lettering with increase/decrease label
- Understandable in any language

Ordering Information			
Part No.	Model No.	Hose Connection	Gas
0382-0355	WH 411C	"B" 9/16"-18 (CGA 022 & 023)	All



### Exclusive "OPTIMIZED" nozzles with a large choice of types and sizes, plus uniformity of tip orifice and size for all series

Victor offers a complete range of nozzles, tips and elbows with a size for every application including: welding, brazing, heating, descaling, hard facing, flame priming, etc.

#### Nozzles Designed for "Optimum" Performance

Each complete nozzle has its own built-in spiral mixer, individually designed for each tip size and flame characteristic. Each nozzle is individually swaged to insure proper alignment for uniform flame, sizing and free-flow contour.

#### Orifice Sizes are Common for All Series

Regardless of nozzle series (W, W-1, W-J), flame characteristic or fuel gas used. The uniformity of orifice sizes simplifies nozzle selection, eliminates chances of ordering and wrong size when changing from one type of nozzle to another.

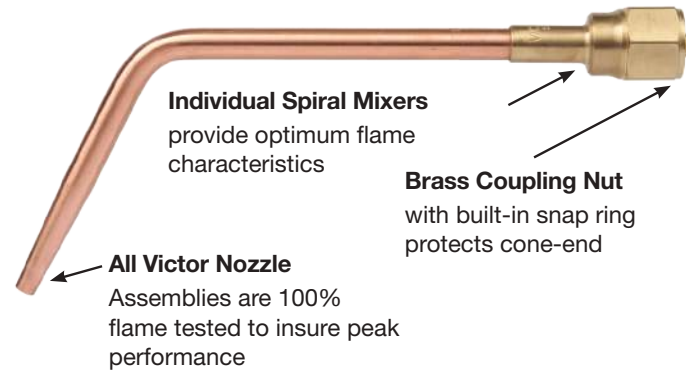

**Double O-ring Seal**  
Provides gas-tight connection without wrench

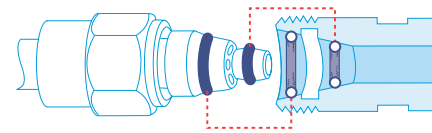

Flame orifice size the same for all nozzle series

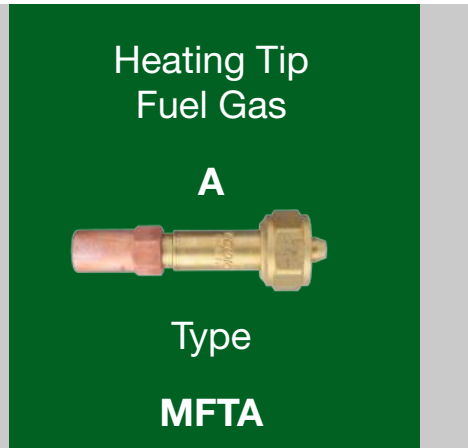
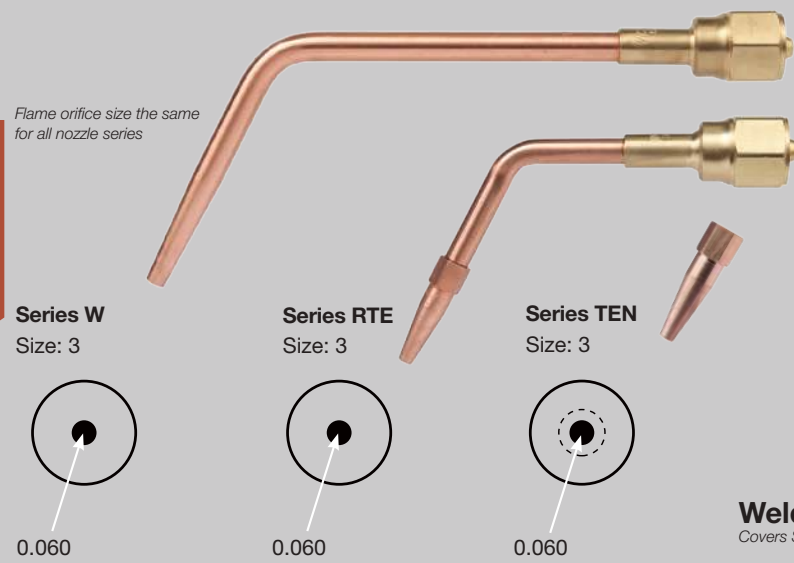

#### Welding Nozzle Operational Data/Acetylene

Covers Series W (Heavy Duty), W-1 (Medium Duty) And W-J (Light Duty) Series

Oxy-Acetylene & Oxy-Hydrogen				
Application	Torch Series	Nozzle Type	Available Sizes	Illustration
General purpose welding & heating. Uses replaceable tip ends. Flame characteristic - Long cone	315FC H 315FC	RTE	000-6, 8, 10	 Sizes: 000-6, 8 (Length 4.5") Size: 10 (Length 14")
General purpose welding & preheating. Swaged one-piece copper elbow. Flame characteristic - Long cone	315FC 100FC J-28 J-40	W W-1 W-J	000-8, 10 000-7 000-4	 Sizes: 000-8 (Length 4.5") Size: 10 (Length 14")

Operational & Performance Data					
Metal Thickness	Tip Size	Drill Size	Oxygen (psig)	Acetylene (psig)	Acetylene (Scfh)
1/32 in. (0.8 mm)	000	75 (0.022)	3/5	3/5	1/2
3/64 in. (1.2 mm)	00	70 (0.028)	3/5	3/5	1.5/3
5/64 in. (1.9 mm)	0	65 (0.035)	3/5	3/5	2/4
3/32 in. (2.4 mm)	1	60 (0.040)	3/5	3/5	3/6
1/8 in. (3.2 mm)	2	56 (0.046)	3/5	3/5	5/10
3/16 in. (4.8 mm)	3	53 (0.060)	4/7	3/6	8/18
1/4 in. (6.4 mm)	4	49 (0.073)	5/10	4/7	10/25
1/2 in. (12.7 mm)	5	43 (0.089)	6/12	5/8	15/35
3/4 in. (19.0 mm)	6	36 (0.106)	7/14	6/9	25/45
1 1/4 in. (32.0 mm)	7	30 (0.128)	8/16	8/10	30/60
2 in. (51.0 mm)	8	29 (0.136)	10/19	9/12	35/75
3 in. (76.2 mm)	10	27 (0.144)	12/24	12/15	50/100

WARNING: At no time should the withdrawal rate of an individual acetylene cylinder exceed 1/7 of the cylinder contents per hour. If additional flow capacity is required use an acetylene manifold system of sufficient size to supply the necessary volume.

Oxygen consumption (SCFH) is 1.1 times the acetylene under neutral flame conditions.

## TYPE 55/55-1 MULTI-FLAME HEATING NOZZLES

Use with 300, HD 310C Series Torch Handles  
Victor Heavy Industry

The Type 55 Series multi-flame heating nozzles feature a raised center point on the head to prevent bumping the plate and compressing the flame. The center point and improved mixer design combine to provide greater resistance to sustained backfire and improved flow performance. Type 55s can be ordered as a complete assembly or as individual components.

- High capacity heating head for heat treating, straightening, and priming
- LP Gases

Ordering Information				
Part No.	Type	Available size	Available Length	Series
0323-0326	55	20*	28 in. (711.2 mm)	HD 310C
0323-0325	55	15*	28 in. (711.2 mm)	HD 310C
0323-0324	55	10*	28 in. (711.2 mm)	HD 310C
0323-0328	55	8	11 in. (279.4 mm)	HD 310C/300
0323-0327	55	6	11 in. (279.4 mm)	300
0324-0188	55-1	6	11 in. (279.4 mm)	100

\*Size 10, 15 and 20 Type 55 heating nozzles must be used with HD 310C torch handle and 3/8 in. (9.5 mm) hose.

**WARNING:** Not for use with acetylene

## TYPE 55 COMPONENTS

300 Series

Type 55 Series multi-flames are available as components. Threaded elbows give you the flexibility to easily service or extend the length of the nozzles. Use the special extensions adapter to extend the tip tube to the required length.



Type 55 - for use with Propylene based fuel gases, Methane, Propane, Butane, & pressurized Natural Gas

Tip Size	Oxygen Pressure (psig)	Fuel Pressure (psig)	Oxygen Consumption (SCFH)	Fuel Consumption (SCFH)	BTU/h
20	100/150	30/50	900/1150	400/500	See Chart
15	90/120	20/35	600/800	250/350	
10	70/100	15/25	356/460	150/200	
8	70/85	15/25	220	85	
6	70/80	15/20	160	65	



#### BTU Per Hour

To approximate gross BTU output, multiply flow rate by BTU value listed below:

Propane	2498
Natural Gas	1000
Butane	3374
Propylene	2371

#### Warning:

- Use flashback arrestors
- Although built to Victor's quality and safety standards, due to the cutting capacity and/or design of each torch, flashback arrestors are not manufactured into the 310C Series Victor heavy industry torches
- To reduce the risk of personal injury, death and/or property damage, use sufficient capacity flashback arrestors with all Victor heavy industry torch products
- Alternative fuel gas only refers to propane, natural gas, propylene gases. Acetylene, hydrogen and gasoline are NOT included as an alternative gas

Ordering Information					
Part No.	Available Size	Application/Description	Available Length	Available Angles	Series
0311-0232	20*	Multi-Flame Heads	-	-	HD 310C
0311-0231	15*	Multi-Flame Heads	-	-	HD 310C
0311-0230	10*	Multi-Flame Heads	-	-	HD 310C
0311-0241	8	Multi-Flame Heads	-	-	HD 310C/300
0311-0240	6	Multi-Flame Heads	-	-	300
0304-0002	-	Multi-Flame Elbows	14 in. (355.6 mm)	65°	HD 310C/300
0304-0095	-	Multi-Flame Elbows	16 in. (406.4 mm)	180°	HD 310C/300
0304-0011	-	Multi-Flame Elbows	26 in. (660.4 mm)	65°	HD 310C/300
0328-0012	Mixer and nut assembly, for use with pressures from 10 psig and up.				HD 310C/300
0328-0013	Mixer and nut assembly, for use with pressures from 2 - 10 psig.				HD 310C/300
0312-0064	Extension Adapter - Thread specifications: 1/4" - 18 NPT(F) X 1/2" - 27 UNS(F)"				HD 310C/300

\*Size 10, 15 and 20 Type 55 heating nozzles must be used with HD 310C torch handle and 3/8 in. (9.5 mm) hose.



# MFN/MFN-1 HEATING NOZZLES

Use with 100, 300 & HD310C Series Torch Handles  
Victor Heavy Industry

- Multi-flame heating head for preheating, priming and straightening
- LP Gases



Ordering Information					
Part No.	Type	Size	Tip End Replacement	Length	Series
0323-0303	MFN	12"	-	17.5" (444.5 mm)	HD 310C
0323-0304	MFN	15"	-	17.5" (444.5 mm)	HD 310C
0323-0305	MFN	20"	-	17.5" (444.5 mm)	HD 310C
0323-0292	MFN	8	-	12.0" (304.8 mm)	300
0323-0302	MFN	10	-	17.5" (444.5 mm)	300
0324-0117	MFN-1	6	0311-0611	12.0" (304.8 mm)	100
0324-0118	MFN-1	8	0311-0612	12.0" (304.8 mm)	100

\*Size 12, 15 and 20 MFN heating nozzles must be used with HD 310C torch handle and 3/8 in. (9.5 mm) hose.

**WARNING:** Not for use with acetylene

Type MFN, MFN-1 – for use with Propane & Natural Gas

Tip Size	Oxygen Pressure (psig)	Fuel Pressure (psig)	Oxygen Consumption (SCFH)	Fuel Consumption (SCFH)	BTU Per Hour
6	8/20	2/10	20/80	5.5/20	See Chart
8	10/20	10/15	40/140	10/35	
10	10/30	12/20	80/320	20/80	
12	30/125	15/25	120/640	30/160	
15	30/125	15/25	200/800	50/200	
20	40/135	15/25	300/1000	75/250	

### BTU Per Hour

To approximate gross BTU output, multiply flow rate by BTU value listed below:

Propane	2498
Natural Gas	1000
Butane	3374
Propylene	2371

### Warning:

- Use flashback arrestors
- Although built to Victor's quality and safety standards, due to the cutting capacity and/or design of each torch, flashback arrestors are not manufactured into the 310C Series Victor heavy industry torches
- To reduce the risk of personal injury, death and/or property damage, use sufficient capacity flashback arrestors with all Victor heavy industry torch products
- Alternative fuel gas only refers to propane, natural gas, propylene gases. Acetylene, hydrogen and gasoline are NOT included as an alternative gas

# MFA/MFA-1 HEATING NOZZLES

Use with J, 100, 300 & HD310C Series Torch Handles  
Victor Heavy Industry

- Multi-flame heating head for heat treating, straightening and priming
- Acetylene / Hydrogen



Ordering Information						
Part No. Boxed	Part No. Clamshell	Type	Size	Tip End Replacement	Length	Series
0323-0261	0387-0064	MFA	12	0311-0540	17.5" (444.5 mm)	HD 310C
0323-0262	0387-0065	MFA	15	-	17.5" (444.5 mm)	HD 310C
0323-0250	0387-0060	MFA	4	0311-0536	12.0" (304.8 mm)	300
0323-0251	0387-0061	MFA	6	0311-0537	12.0" (304.8 mm)	300
0323-0252	0387-0062	MFA	8	0311-0538	12.0" (304.8 mm)	300
0323-0260	0387-0063	MFA	10	0311-0539*	12.0" (304.8 mm)	300
0324-0108	-	MFA-1	2	0311-0598	12.0" (304.8 mm)	100
0324-0109	0387-0071	MFA-1	4	0311-0599	12.0" (304.8 mm)	100
0324-0110	0387-0072	MFA-1	6	0311-0600	12.0" (304.8 mm)	100
0324-0111	0387-0073	MFA-1	8	0311-0601	12.0" (304.8 mm)	100
0325-0104	-	MFA-J	2	-	-	J
0325-0105	-	MFA-J	4	-	-	J
0325-0106	0387-0077	MFA-J	6	-	-	J

\*Size 12, 20 and MFA heating nozzles must be used with HD 310C torch handle and 3/8 in. (9.5 mm) hose.

Type MFA, MFA-1 – for use with Acetylene

Tip Size	Oxygen Pressure (psig)	Acetylene Pressure (psig)	Oxygen Consumption (SCFH)	Acetylene Consumption (SCFH)	BTU Per Hour
2	4/8	4/8	3/10	3/9	See Chart
4	8/12	6/10	7/22	6/20	
6	10/15	8/12	15/44	14/40	
8	20/30	10/15	33/88	30/80	
10	30/40	12/15	44/110	40/100	
12	50/60	12/15	66/165	60/150	
15	50/60	12/15	99/244	90/220	

### BTU Per Hour

To approximate gross BTU output, multiply flow rate by BTU value listed below:

Acetylene	1470
Methane	1000

### Warning:

At no time should the withdrawal rate of an individual acetylene cylinder exceed 1/7 of the cylinder contents per hour. If additional flow capacity is required use an acetylene manifold system of sufficient size to supply the necessary volume.

# SERIES 1 HEATING TIPS

Type MFTA – Acetylene



For preheating before welding, descaling and paint burning, etc.

Ordering Information	
Size	Part No.
6	0330-0527
8	0330-0528
*10	0330-0523
*12	0330-0524

\*Use 3/8 in. (9.5 mm) hose and straight torch  
Required pressures: 12/15 Acetylene; 70/80 psig Oxygen  
Size 8 is maximum size for use with cutting attachments

Type MFTN – LP (Propane/Natural Gas)



For preheating before welding, descaling and paint burning, etc.

Ordering Information	
Size	Part No.
10	0330-0521
12	0330-0522

Not for use with cutting attachments

# CHT ADAPTOR

- Concentrated Heating Tip Adaptor for straightening, bending and forming of plate
- For Use with Alternate Fuels
- Use with HPP or HPN size 5 cutting tip, multi-flame elbow, or mixer and nut assembly



Ordering Information	
Part No.	Series
CHT Adaptor	0312-0089

# WELDING NOZZLES

W Series

For use with 300 Series torch handles



W-1 Series

For use with 100 Series torch handles



W-J Series

For use with J Series torch handles



- General purpose welding & preheating
- Fuel gas usage - acetylene, hydrogen
- 65° tip angle
- Long cone flame
- One piece copper elbow tip

Ordering Information				
Model	Size	Part No. Boxed	Part No. Clamshell	Series
W	000	0323-0110	-	300
	00	0323-0111	0387-0019	300
	0	0323-0112	0387-0020	300
	1	0323-0120	0387-0021	300
	2	0323-0121	0387-0022	300
	3	0323-0122	0387-0023	300
	4	0323-0130	0387-0024	300
	5	0323-0131	-	300
	6	0323-0132	-	300
	7	0323-0140	-	300
W-1	8	0323-0141	-	300
	10	0323-0142	-	300
	000	0324-0068	0387-0028	100
	00	0324-0069	0387-0029	100
	0	0324-0070	0387-0030	100
	1	0324-0071	0387-0031	100
	2	0324-0072	0387-0032	100
	3	0324-0073	0387-0033	100
	4	0324-0074	0387-0034	100
	5	0324-0075	-	100
W-J	6	0324-0076	-	100
	000	0325-0081	-	J
	00	0325-0082	0387-0039	J
	0	0325-0083	0387-0040	J
	1	0325-0084	0387-0041	J
	2	0325-0085	0387-0042	J
	3	0325-0086	0387-0043	J
	5	0325-0088	-	J
6	0325-0089	-	J	
7	0325-0090	-	J	



# ELBOW TIPS

## ET Series

For use with 300 Series torch handles



## ET-1 Series

For use with 100 Series torch handles



## ET-J Series

For use with J Series torch handles



- One piece copper elbow tip
- Long cone flame
- Fuel gas usage - acetylene, hydrogen

Ordering Information			
Model	Size	Part No.	Series
ET	000	0311-0055	300
	00	0311-0056	300
	0	0311-0057	300
	1	0311-0058	300
	2	0311-0059	300
	3	0311-0572	300
	4	0311-0573	300
	5	0311-0574	300
	6	0311-0575	300
	7	0311-0576	300
ET-1	3	0311-0073	300
	4	0311-0345	100
	5	0311-0340	100
	6	0311-0602	100
ET-J	000	0311-0603	100
	00	0311-0123	J
	0	0311-0124	J
	1	0311-0125	J
ET-J	2	0311-0126	J
	3	0311-0127	J
	4	0311-0128	J
	4	0311-0129	J

# UM SERIES UNIVERSAL MIXERS

Oxy-Acetylene universal mixers used when exact performance & Individual nozzles are not needed.



Ordering Information					
Type	Part No.	Fuel Gas Usage	Elbow Tips	Length	Series
4-UM-1	0328-0005	Oxy-Acetylene	000-2 ET, 3 ET-1, 4 ET-1	1.75" (44.5 mm)	100
7-UM-1	0328-0009	Oxy-Acetylene	5 ET-1, 6 ET-1	1.75" (44.5 mm)	100

# RTE SERIES REPLACEABLE TIP ENDS

For use with 300 Series torch handles

- General purpose welding & preheating
- Uses replacement tip ends (TE Series)
- 65° tip angle

# RTE SERIES

- General purpose brazing & preheating
- Long cone flame
- Uses TEN tip ends



Ordering Information				
Model	Size	Part No.	Fuel Gas Usage	Series
RTE	00	0323-0307	Acetylene, Hydrogen	300
	0	0323-0308	Acetylene, Hydrogen	300
	1	0323-0309	Acetylene, Hydrogen	300
	2	0323-0310	Acetylene, Hydrogen	300
	3	0323-0311	Acetylene, Hydrogen	300
	4	0323-0312	Acetylene, Hydrogen	300
	5	0323-0313	Acetylene, Hydrogen	300
	6	0323-0314	Acetylene, Hydrogen	300
	8	0323-0316	Acetylene, Hydrogen	300
	10	0323-0317	Acetylene, Hydrogen	300
RTE N	6	0323-0284	Natural Gas, Propane	300

# FE SERIES FLEXIBLE ELBOW



- Flexible elbow for special welding, brazing, and heating needs
- Multi-fuel gas service
- Uses replaceable tip ends
- Thread: 5/16"-27

Ordering Information					
Type	Part No.	Fuel Gas Usage	Tip End Replacements	Length	Series
FE	0323-0191	Multi-Gas Fuel Service	TE, TEN, TEMFA, TEMFN, TEMF	11.5 in. (292.1 mm)	300
FE-1	0324-0066	Multi-Gas Fuel Service	TE, TEN, TEMFA, TEMFN, TEMF	11.5 in. (292.1 mm)	100
FE-J	0325-0102	Multi-Gas Fuel Service	TE, TEN, TEMFA, TEMFN, TEMF	11.5 in. (292.1 mm)	J

# UN SERIES UNIVERSAL NOZZLE

- Standard bend nozzle for welding, brazing and heating
- Uses replaceable tip ends
- 65° tip angle
- Thread: 5/16"-27



Ordering Information					
Type	Part No.	Fuel Gas Usage	Tip End Replacements	Length	Series
UN	0323-0242	Multi-Gas Fuel Service	TE, TEN, TEMFA, TEMFN, TEMF	5 in. (127.0 mm)	300
UN-1	0324-0094	Multi-Gas Fuel Service	TE, TEN, TEMFA, TEMFN, TEMF	5 in. (127.0 mm)	100
UN-J	0325-0101	Multi-Gas Fuel Service	TE, TEN, TEMFA, TEMFN, TEMF	5 in. (127.0 mm)	J

# DFE SERIES DUAL FLEXIBLE ELBOW

- Dual flexible elbow nozzle assembly for special welding, brazing and heating
- Uses replaceable tip ends
- Thread: 5/16"-27



Ordering Information				
Type	Part No.	Fuel Gas Usage	Tip End Replacements	Series
DFE	0323-0192	Multi-Gas Fuel Service	TE, TEN, TEMFA, TEMFN, TEMF	300
DFE-1	0324-0092	Multi-Gas Fuel Service	TE, TEN, TEMFA, TEMFN, TEMF	100
DFE-J	0325-0108	Multi-Gas Fuel Service	TE, TEN, TEMFA, TEMFN, TEMF	J

# REPLACEABLE TIP ENDS

TE, TEN, TEMFA, TEMFN & TEMF 300, 100 & J Series



For All Nozzles Using Replaceable Tip Ends		
Type	Application, Description	Fuel Gas
TE	Welding, brazing Flame – long Cone One piece	Acetylene
TEN	Brazing, silver brazing Flame – long Cone One piece	Natural Gas, Propane
TEMFA	Brazing, silver brazing, heating Flame – multi-flame One piece	Acetylene
TEMFN	Brazing, silver brazing, heating Flame – multi-flame One piece	All Fuel Gases Except Acetylene
TEMF	Brazing, soldering, heating Flame – multi-flame Two piece	All Fuel Gases Except Acetylene

Tip Size, Length, Thread Size					
Type	Size(s)	Length	Thread	Part No.	
TE	000	1.5 in. (38.1 mm)	5/16-27	0311-0471	
	00	1.5 in. (38.1 mm)	5/16-27	0311-0472	
	0	1.5 in. (38.1 mm)	5/16-27	0311-0473	
	1	1.5 in. (38.1 mm)	5/16-27	0311-0474	
	2	1.5 in. (38.1 mm)	5/16-27	0311-0475	
	3	1.63 in. (41.4 mm)	5/16-27	0311-0587	
	4	1.88 in. (47.8 mm)	5/16-27	0311-0588	
	5	2 in. (50.8 mm)	5/16-27	0311-0589	
	6	2.25 in. (57.2 mm)	0.393-27	*0311-0590	
	8	2.75" (69.9 mm)	0.393-27	*0311-0592	
TEN	10	3" (76.2 mm)	0.440-27	*0311-0593	
	0	1.5 in. (38.1 mm)	5/16-27	0311-0483	
	2	1.5 in. (38.1 mm)	5/16-27	0311-0485	
	3	1.63 in. (41.4 mm)	5/16-27	0311-0486	
	4	1.88 in. (47.8 mm)	5/16-27	0311-0487	
	5	2 in. (50.8 mm)	5/16"-27	0311-0488	
	6	2.25 in. (57.2 mm)	0.393-27	*0311-0585	
	TEMFA	1	1.5 in. (38.1 mm)	5/16-27	0311-0215
		2	1.5 in. (38.1 mm)	5/16-27	0311-0216
		3	1.5 in. (38.1 mm)	5/16-27	0311-0217
4		1.5 in. (38.1 mm)	5/16-27	0311-0218	
5		1.5 in. (38.1 mm)	5/16-27	0311-0219	
TEMFN	3	1.5 in. (38.1 mm)	5/16-27	0311-0306	
	4	1.5 in. (38.1 mm)	5/16-27	0311-0307	
	5	1.5 in. (38.1 mm)	5/16-27	0311-0308	
TEMF	6	1.5 in. (38.1 mm)	5/16-27	0311-0676	
	7	1.5 in. (38.1 mm)	5/16-27	0311-0677	
	8	1.5 in. (38.1 mm)	5/16-27	0311-0678	
	9	1.5 in. (38.1 mm)	5/16-27	0311-0679	
	10	1.5 in. (38.1 mm)	5/16-27	0311-0680	

Adapter for tip ends to fit tip tube: 5/16"-27(F) x 1/8"-27(M) 0312-0071 \*Fit nozzles RTE only

NOZZLES

NOZZLES



### Victor “Universal Torches”

They combine the spiral and injector mixer principles. The result is a high performance torch that operates on any fuel gas.

Universal torch cutting capacity from 1/8 in. (3.2 mm) to 8 in. (203.2 mm).

Model ST 2600FC Illustrated  
U.S. Patent #5407348

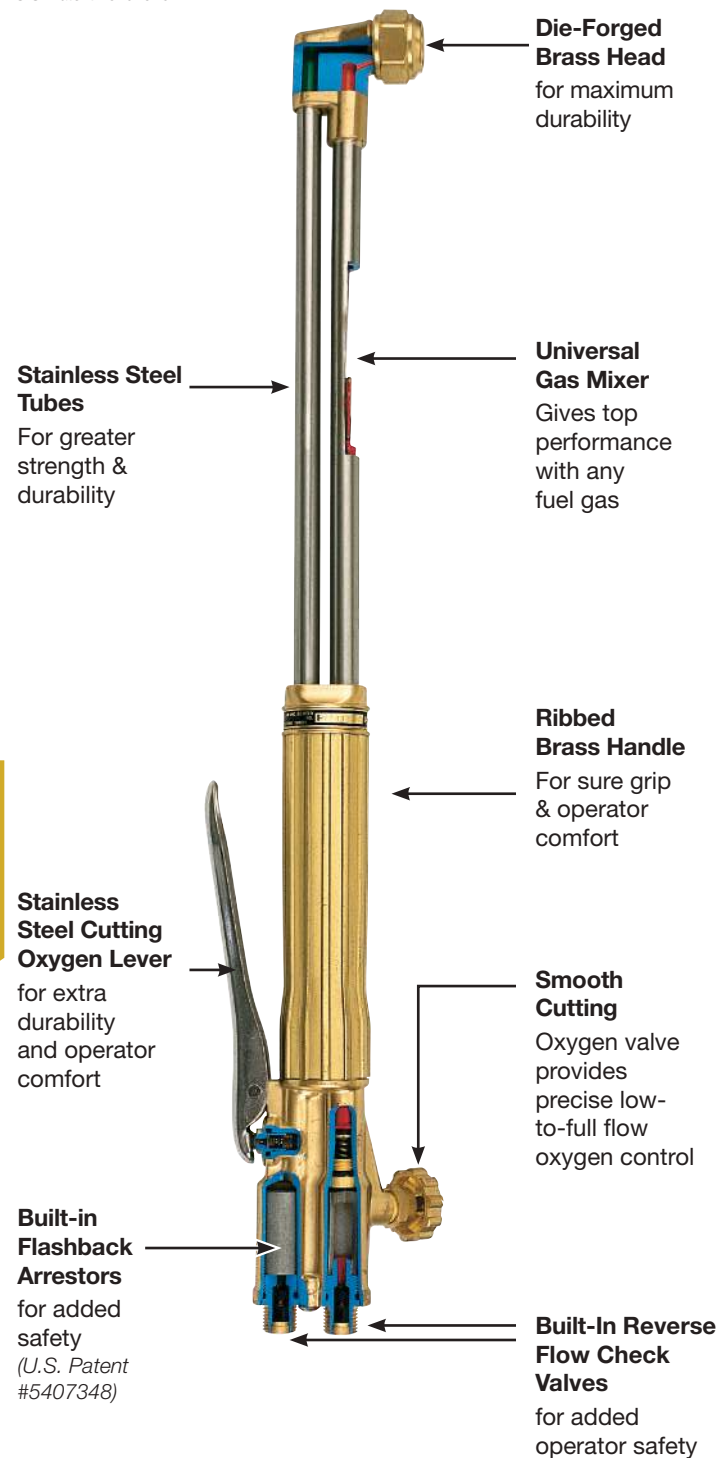

The high capacity straight torches in this section are designed for heavy cutting applications found in such industries as scrapping, demolition and foundries.

Although built to Victor’s quality and safety standards, due to the cutting capacity and/or design of each torch, flashback arrestors are not manufactured into these Victor Heavy Industry torches.

**WARNING:** Use add-on flashback arrestors

To reduce the risk of personal injury, death and/or property damage, use sufficient capacity flashback arrestors with all Victor Heavy Industry torch products.

Alternative fuel gas only refers to propane, natural gas, propylene gases. **Acetylene, hydrogen and gasoline are NOT** included as an alternative gas.

**Do you need special length torches?**  
If you don't see what you need contact  
**Technical Services**

**1-800-569-0547**

**Reference Heavy Industry Products**  
Victor welcomes your request for special length torches.

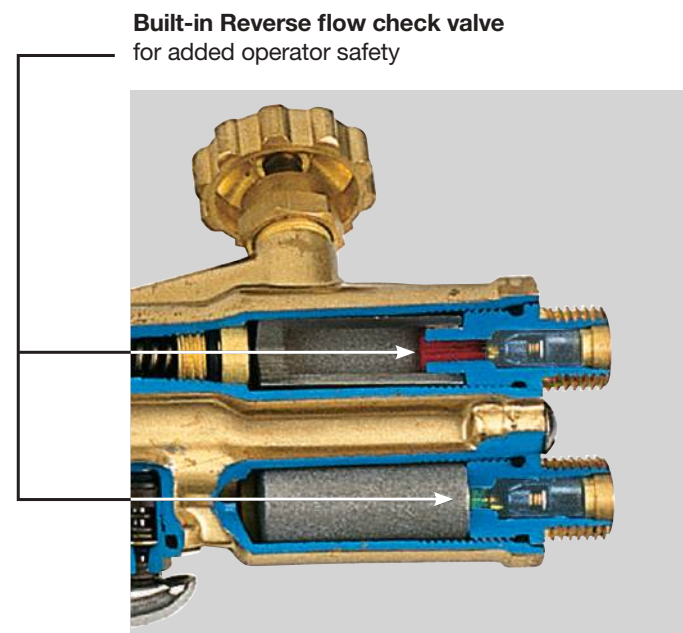

Most Victor Hand Cutting Torches are equipped with built-in reverse flow check valves and flash arrestors

## ST 2600FC SERIES

Heavy Duty Straight Cutting Torch



For use with all fuel gases with appropriate tip.

- Cutting capacity 1/8 in. (3.2 mm) to 8 in. (203.2 mm)
- Includes built-in patented flashback arrestors and reverse flow check valves for added safety

### Ordering Information

Part No.	Model No.	Lever Position	Tip Series	Head Angle	Length
0381-1486	SST 2600FC	Top Rear	1	90°	17 in. (43.2 cm)
0381-1487	SST 2601FC	Top Rear	1	75°	17 in. (43.2 cm)
0381-1480	ST 2600FC	Top Rear	1	90°	21 in. (53.3 cm)
0381-1482	ST 2601FC	Top Rear	1	75°	21 in. (53.3 cm)
0381-1483	ST 2601FCL*	Top Rear	1	75°	21 in. (53.3 cm)
0381-1484	ST 2602FC	Top Rear	1	180°	21 in. (53.3 cm)
0381-1490	ST 2610FC	Top Rear	1	90°	27 in. (68.6 cm)
0381-1491	ST 2611FC	Top Rear	1	75°	27 in. (68.6 cm)
0381-1492	ST 2612FC	Top Rear	1	180°	27 in. (68.6 cm)
0381-1496	ST 2630FC	Top Rear	1	90°	36 in. (91.4 cm)
0381-1498	ST 2631FC	Top Rear	1	75°	36 in. (91.4 cm)
0381-1500	ST 2632FC	Top Rear	1	180°	36 in. (91.4 cm)
0381-1502	ST 2650FC	Top Rear	1	90°	48 in. (121.9 cm)
0381-1503	ST 2651FC	Top Rear	1	75°	48 in. (121.9 cm)
0381-1514	ST 2651FCL*	Top Rear	1	75°	48 in. (121.9 cm)
0381-1504	ST 2652FC	Top Rear	1	180°	48 in. (121.9 cm)
0381-1515	ST 2652FCL*	Top Rear	1	180°	48 in. (121.9 cm)
0381-1506	ST 2670FC	Top Rear	1	90°	72 in. (182.9 cm)
0381-1508	ST 2671FC	Top Rear	1	75°	72 in. (182.9 cm)
0381-1510	ST 2672FC	Top Rear	1	180°	72 in. (182.9 cm)

\*Locking lever

## ST 1000FC SERIES

Heavy Duty Straight Cutting Torch



For use with all fuel gases with appropriate tip.

- Cutting capacity 1/8 in. (3.2 mm) to 5 in. (127.0 mm)
- Includes built-in patented flashback arrestors and reverse flow check valves for added safety
- Built-in flashback arrestors no need for accessory flash arrestors
- Built-in reverse flow check valves no need for accessory check valves

### Ordering Information

Part No.	Model No.	Lever Position	Tip Series	Head Angle	Length
0381-1640	SST 1000FC	Bottom Rear	1	90°	17 in. (43.2 cm)
0381-1642	SST 1001FC	Bottom Rear	1	75°	17 in. (43.2 cm)
0381-1641	ST 1000FC	Bottom Rear	1	90°	21 in. (53.3 cm)
0381-1643	ST 1001FC	Bottom Rear	1	75°	21 in. (53.3 cm)
0381-1644	ST 1030FC	Bottom Rear	1	90°	36 in. (91.4 cm)
0381-1645	ST 1031FC	Bottom Rear	1	75°	36 in. (91.4 cm)
0381-1646	ST 1032FC	Bottom Rear	1	180°	36 in. (91.4 cm)
0381-1647	ST 1050FC	Bottom Rear	1	90°	48 in. (121.9 cm)
0381-1648	ST 1051FC	Bottom Rear	1	75°	48 in. (121.9 cm)
0381-1649	ST 1052FC	Bottom Rear	1	180°	48 in. (121.9 cm)



# ST 900FC SERIES

Heavy Duty Straight Cutting Torch



For use with all fuel gases with appropriate tip.

- Cutting capacity: 1/8 in. (3.2 mm) to 5 in. (127.0 mm)
- Hose connections are 9/16" - 18 unless noted
- Includes built-in patented flashback arrestors and reverse flow check valves for added safety
- Built-in flashback arrestors no need for accessory flash arrestors
- Built-in reverse flow check valves no need for accessory check valves

Ordering Information					
Part No.	Model No.	Lever Position	Tip Series	Head Angle	Length
0381-1620	SST 900FC	Top Rear	1	90°	17 in. (43.2 cm)
0381-1622	SST 901FC	Top Rear	1	75°	17 in. (43.2 cm)
0381-1621	ST 900FC	Top Rear	1	90°	21 in. (53.3 cm)
0381-1623	ST 901FC	Top Rear	1	75°	21 in. (53.3 cm)
0381-1628	ST 912FC	Top Rear	1	180°	27 in. (68.6 cm)
0381-1624	ST 930FC	Top Rear	1	90°	36 in. (91.4 cm)
0381-1625	ST 931FC	Top Rear	1	75°	36 in. (91.4 cm)
0381-1626	ST 932FC	Top Rear	1	180°	36 in. (91.4 cm)
0381-1629	ST 950FC	Top Rear	1	90°	48 in. (121.9 cm)
0381-1630	ST 951FC	Top Rear	1	75°	48 in. (121.9 cm)
0381-1631	ST 952FC	Top Rear	1	180°	48 in. (121.9 cm)
0381-1654	ST 972FC	Top Rear	1	180°	72 in. (182.9 cm)
0381-1685	ST 991FC	Top Rear	1	75°	96 in. (243.8 cm)

# ST 400FC SERIES

Heavy Duty



For use with all fuel gases 5 psig and above.

- Cutting capacity up to 6 in. (155 mm)
- Hose connections are 9/16" - 18 unless noted
- Built-in reverse flow check valves no need for accessory check valves

### Special designed alloy Material:

- 3x the tensile strength of Brass
- Ergonomic, textured, precision contoured handle is designed to reduce operator fatigue and provide better grip

### Intuitive knobs:

- Color-coded
- Clearly marked lettering with increase/decrease label
- Understandable in any language

Ordering Information					
Part No.	Model No.	Lever Position	Tip Series	Head Angle	Length
0381-1987	ST 400C	Top Rear	1	90°	21 in. (53.3 cm)

# ST 300FC SERIES

Heavy Duty



For use with all fuel gases with appropriate tip.

- Cutting capacity 1/8 in. (3.2 mm) to 5 in. (127.0 mm)
- Hose connections are 9/16" - 18 unless noted
- Includes built-in patented flashback arrestors and reverse flow check valves for added safety
- Built-in reverse flow check valves

Ordering Information					
Part No.	Model No.	Lever Position	Tip Series	Head Angle	Length
0381-1917	ST 300FC	Top Rear	1	90°	21 in. (53.3 cm)

# BULLDOG™ - HC 1100C

Victor Heavy Industry Scrap Straight Cutting Torch



With Bulldog torches, superior performance and productivity are assured. The low profile head and lightweight design, strength and durability put Bulldog in a class by itself.

The HC 1100C is manufactured without built-in flashback arrestors. Revers flow check valves are installed at the inlet connection

- Patented head and mixer
- Bottom rear lever with pin/clip design
- Specially designed 'supercharged' preheat oxygen valve
- Reduces flame blow-off
- Bottom located valves for right or left hand use
- Threaded inlet connections with integral check valve for ease of repair
- Body designed for high flow applications
- 3 heavy duty tube supports for ultra strength and durability on extra length models
- UltraMix low-pressure mixer specially designed for LP gas
- Sleek low profile head with no protrusions to hinder cutting
- For use with propane and natural gas

### Bulldog tips by Victor offer a cost effective alternative for efficient scrap cutting

- For scrap cutting
- Heavy wall - two piece design
- Resists slag build-up
- Available in Victor and Harris® styles

### Ordering Information

Part No.	Model No.	Lever Position	Tip Series	Head Angle	Overall Length
<b>Victor Bulldog with Victor Head</b>					
0381-1703	HC 1100C	Bottom Rear	1	90°	21 in. (53.3 cm)
0381-1704	HC 1101C	Bottom Rear	1	75°	21 in. (53.3 cm)
0381-1709	HC 1130C	Bottom Rear	1	90°	36 in. (91.4 cm)
0381-1710	HC 1131C	Bottom Rear	1	75°	36 in. (91.4 cm)
0381-1711	HC 1132C	Bottom Rear	1	180°	36 in. (91.4 cm)
0381-1712	HC 1150C	Bottom Rear	1	90°	48 in. (121.9 cm)
0381-1713	HC 1151C	Bottom Rear	1	75°	48 in. (121.9 cm)
0381-1714	HC 1152C	Bottom Rear	1	180°	48 in. (121.9 cm)
0381-1716	HC 1161C	Bottom Rear	1	75°	60 in. (152.4 cm)
0381-1717	HC 1162C	Bottom Rear	1	180°	60 in. (152.4 cm)
0381-1718	HC 1170C	Bottom Rear	1	90°	72 in. (182.9 cm)
0381-1719	HC 1171C	Bottom Rear	1	75°	72 in. (182.9 cm)
0381-1720	HC 1172C	Bottom Rear	1	180°	72 in. (182.9 cm)
<b>Victor Bulldog with Seat Designed for Harris® Style Tip</b>					
0381-1698	HC 1100C H1	Bottom Rear	1	90°	21" (53.3 cm)
0381-1721	HC 1131C H1	Bottom Rear	1	75°	36" (91.4 cm)
0381-1722	HC 1151C H1	Bottom Rear	1	75°	48" (121.9 cm)
0381-1745	HC 1171C H1	Bottom Rear	1	75°	72" (182.9 cm)

Harris® is a registered trademark of the Lincoln Electric Company.

**WARNING:** Use add-on flashback arrestors. Not for use with acetylene.

For best performance, use the following recommended equipment:

### Flashback Arrestors

Gas Service	Part No.	Model	Type	Recommended Tip Size
Oxygen	0657-0010	*FB-O	Torch Mount	Up to size: 8
	0657-0014	FB-OR	Regulator Mount	Up to size: 8
	0657-0076	*FBHC-O	Torch Mount/High Flow	Size: 10 and larger
	0657-0078	FBHC-OR	Regulator Mount/High Flow	Size: 10 and larger
Fuel	0657-0011	*FB-F	Torch Mount	-
	0657-0015	FB-FR	Regulator Mount	-

\*Torch mount models also protect the hose

### Hoses

(Contact local distributor for hose information)

- Oxygen:
  - 3/8 in. (9.53 mm) I.D. with "B" hose (9/16"-18 LH) connections.
  - Use T-grade hose
- Fuel:
  - 3/8 in. (9.53 mm) I.D. with "B" hose (9/16"-18 LH) connections.
  - Use T-grade hose

### Regulators

- Oxygen:
  - ELC4, ESS7-125-540, SR 450D-540, SR 700D-540 cylinder, SR 700E-540 cylinder or L 700D/E-500/750 line supply, LC 350DR 540 liquid cylinder
- Fuel:
  - SR 461D-510 cylinder, SR 711B/C/D-510, L 711B/C/D-500/750 line supply

GAS TORCHES

GAS TORCHES



# HC 1200C SERIES

Victor Heavy Industry



## High Capacity/Heavy Duty

The HC 1200C Series torches are high capacity, heavy duty cutting torches that have a cutting capacity up to 18 in. (45.7 cm). These torches are used in a wide variety of heavy industrial applications that include scrapping and demolition.

The HC 1200C is manufactured without built-in flashback arrestors. Revers flow check valves are installed at the inlet connection.

- For use with any fuel gas, 2 psig and above
- Universal mixer
- Cutting capacity 18 in. (45.7 cm)
- Standard Lengths: 21 in. (53.3 cm) - 96 in. (243.8 cm)
- Uses Series 1 cutting tips
- "B" 9/16"-18 hose connections
- Extra length models available upon request
- Lock down lever kit available. Part number: 0307-0062

Ordering Information			
Torch Part No.	Model No.	Head Angle	Length
0381-1402	HC 1200C	90°	21 in. (53.3 cm)
0381-1403	HC 1201C	75°	21 in. (53.3 cm)
0381-1404	HC 1202C	180°	21 in. (53.3 cm)
0381-1405	HC 1230C	90°	36 in. (91.4 cm)
0381-1406	HC 1231C	75°	36 in. (91.4 cm)
0381-1407	HC 1232C	180°	36 in. (91.4 cm)
0381-1408	HC 1250C	90°	48 in. (121.9 cm)
0381-1432	HC 1250LC*	90°	48 in. (121.9 cm)
0381-1409	HC 1251C	75°	48 in. (121.9 cm)
0381-1415	HC 1252C	180°	48 in. (121.9 cm)
0381-1419	HC 1262C	180°	60 in. (152.4 cm)
0381-1412	HC 1270C	90°	72 in. (182.9 cm)
0381-1413	HC 1271C	75°	72 in. (182.9 cm)
0381-1414	HC 1272C	180°	72 in. (182.9 cm)
0381-1424	HC 1280C	90°	84 in. (213.4 cm)
0381-1418	HC 1290C	90°	96 in. (243.8 cm)

\*Locking Lever

## For best performance, use the following recommended equipment:

### Flashback Arrestors

Gas Service	Part No.	Model	Type	Recommended Tip Size
Oxygen	0657-0010	*FB-O	Torch Mount	Up to size: 8
	0657-0014	FB-OR	Regulator Mount	Up to size: 8
	0657-0076	*FBHC-O	Torch Mount/High Flow	10 and larger
	0657-0078	FBHC-OR	Regulator Mount/High Flow	10 and larger
Fuel	0657-0011	*FB-F	Torch Mount	-
	0657-0015	FB-FR	Regulator Mount	-

\* Torch mount models also protect the hose

### Hoses

(Contact local distributor for hose information)

- Oxygen:
  - 3/8 in. (9.5 mm) I.D. with "B" hose (9/16"-18 LH) connections
  - Use T-grade hose
- Fuel:
  - 3/8 in. (9.5 mm) I.D. with "B" hose (9/16"-18 LH) connections
  - Use T-grade hose

### Regulators

- Oxygen:
  - ELC4, ESS7-125-540, SR 450D- 540 Cylinder, SR 700D-540 cylinder or L 700D/E-500/750 line supply
- Fuel:
  - SR 461D-510 cylinder, SR 711B/C/D-510 or L 711B/C/D-500/750 line supply

# HC 1500C

Victor Heavy Industry

## Three hose scrap straight cutting torches



The HC 1500C Series is a three hose design with a 48 in. cutting capacity and is ideal for heavy steel, scrap cutting. The torch has "C" 7/16"-14 (RH) oxygen connection and standard "B" 9/16"-18 oxygen/fuel preheat connections.

The HC 1500C is manufactured without built-in flashback arrestors. Reverse flow check valves are installed at the inlet connection.

- Three hose connection
- Extra heavy duty
- Cutting capacity 48 in. (121.9 cm)
- Length: 56 in. (142.2 cm)
- For use with propane or natural gas
- Not for use with acetylene
- Uses Series 2-285N (two piece) cutting tips
- Special lengths available on request

Ordering Information							
Part No.	Model No.	Head Angle	Hose Connection Preheat	Hose Connection Cutting (Oxygen)	Length	Fuel Gas	Cutting Capacity
0381-0444	HC 1500C	180°	"B" 9/16"-18 LH & RH	"C" 7/8 in. -14 RH	48 in. (121.9 cm)	Natural Gas & Propane	48 in. (121.9 cm)
0381-0509	HC 1500C	90°	"B" 9/16"-18 LH & RH	"C" 7/8 in. -14 RH	84 in. (213.4 cm)	Natural Gas & Propane	48 in. (121.9 cm)
0381-0515	HC 1500C	90°	"B" 9/16"-18 LH & RH	"C" 7/8 in. -14 RH	96 in. (243.8 cm)	Natural Gas & Propane	48 in. (121.9 cm)

Uses Series 2-285N (two piece) cutting tips. See chart below

## Flashback Arrestors

Gas Service	Part No.	Model	Type
Cutting Oxygen	Not required		
Preheat Oxygen	0657-0076	*FBHC-O	Torch Mount
	0657-0078	FBHC-OR	Regulator Mount

\*Torch mount models also protect the hose

**WARNING:** Use add-on flashback arrestors. Not for use with acetylene.

## For best performance, use the following recommended equipment:

### Hoses

(Contact local distributor for hose information)

- Cutting Oxygen:
  - 1/2 in. I.D. with "C" hose (7/16"-14 RH) connections
  - Use T-grade or RM-grade hose
- Preheat Oxygen:
  - 3/8 in. I.D. with "B" hose (9/16"-18 RH) connections
  - Use T-grade hose
- Preheat Fuel:
  - 3/8 in. I.D. with "B" hose (9/16"-18 LH) connections
  - Use T-grade hose

### Regulators

- Cutting Oxygen:
  - ELC4, ESS7-125-540, SR 700D-540, or S or L 700D-500/750 line supply
- Preheat Oxygen:
  - SR 450D-540, or S or L 700D-500/750 line supply
- Preheat Fuel:
  - SR 461D-510, or S or L 711D-500/750 line supply

## 2-285N Two Piece Tips – for use with HC 1500C torches

Part No.	Model No.	Size	Cutting Range	Cutting Orifice Dia.	*Cutting Oxygen (psig)	Cutting Oxygen (SCFH)	Preheat Oxygen (psig)	Preheat Oxygen (SCFH)	*Fuel (psig)	Fuel (SCFH)
0336-0041	2-285N	0.25	14" to 20"	0.25	25/45	1500/2400	25/50	250/400	15/20	60/120
0336-0042	2-285N	0.312	20" to 26"	0.312	25/45	2300/3500	25/50	250/400	15/20	60/120
0336-0043	2-285N	0.375	26" to 34"	0.375	20/40	2300/3900	25/50	250/400	15/20	60/120
0336-0044	2-285N	0.437	34" Over	0.437	20/40	2400/4500	25/50	250/400	15/20	60/120

\*Pressure is measured at back of torch when torch is flowing

Oxygen Consumption:

1. Adequate volume required. Dual supplies recommended when using cylinders.
2. When operating from bulk oxygen supply it is recommended that separate oxygen drop stations are used.





# HAND SCARFING CUTTING TORCHES

Steel Industry Products

## C-59 Scarfing/Cutting Torch

- Scarfing widths from 2-1/2-3-3/16 in. (63.5-81 mm)
- Cuts 20-60 in. (508-1524 mm)
- Alternate fuels
- High capacity emergency hand cutting
- Uses 1800 series cutting tips
- C-59 available with or without rod feed, which improves starts

### Ordering Information

Model	Length		Degree	Part Number
	in.	m		
C-59-36-75	36	0.9	75	02X67
C-59-48-75	48	1.2	75	02X68
C-59-48-75NRF	48	1.2	75	02X92
C-59-48-180NRF	48	1.2	180	5278749
C-59-56-75NRF	56	1.4	75	526438
C-59-72-75	72	1.8	75	5278595
C-59-72-180NRF	72	1.8	180	5278980
C-59-108-75NRF	108	2.7	75	5278890
C-59-108-90NRF	108	2.7	90	2217963
C-59-108-180NRF	108	2.7	180	5279250
C-59-120-75NRF	120	3.0	75	2217964
C-59-120-90NRF	120	3.0	90	2217965
C-59-144-90NRF	144	3.7	90	2217967
C-59-144-180NRF	144	3.7	180	2217968

Note: NRF = No rod feed.

### Specifications

Model	Cutting Range		Scarfing Range		Tip Series
	in.	mm	in.	mm	
C-59	20-60	508-1524	2-1/2-3-3/16	63.5-81	1800

### Options & Accessories

Riding Skid Assembly  
C-59..... 5279716

Replacement Heads, C-59  
75° ..... 83Z97  
90° ..... 2117835  
180° ..... 83Z92

### Hose Requirements

Oxygen ..... 1/2 in. (13 mm), "C" Size  
Fuel gas ..... 3/8 in. (9.5 mm), "B" Size



# HAND CUTTING TORCHES

Steel Industry Products

## OXWELD C-63



- Cutting range 9-60 in. (229-1524 mm)
- Alternate fuels
- Separate preheat and cutting oxygen inlets
- Off-center 180° head allows kerf to be widened by rotating torch; torch can then be inserted into kerf to deepen cut
- Use 1808 series cutting tips

### Ordering Information

Model	Length		Degree	Part Number
	in.	m		
C-63	60	1.5	180	27X05
	60	1.5	75	5279010
	72	1.8	180	2219219

### Hose Requirements

C-63  
Preheat ..... "B" size  
Cut oxygen ..... 1/2 in. (13 mm), "C" size

### Riding Skid Assembly

C-63 ..... 5279716

## C-66-1400 Series



- Cutting range 3-28 in. (76 - 711 mm)
- Alternate fuels
- Reliable emergency hand cutting in production mill environments
- Designed for extra heavy-duty operations for long trouble-free service life
- Torch lengths from 2.5 - 17 ft. (0.8 - 5 m)
- Torches 9 ft. (2.7 m) and over have protective out channel
- Off-center 180° head allows kerf to be widened by rotating torch; torch can then be inserted into kerf to deepen cut
- Use 1400 series cutting tips
- Fast, efficient scrap cutting

### Ordering Information

Model	Length		Degree	Part Number
	in.	m		
C-66-1400	48	1.2	75	718321
	48	1.2	90	2120361
	48	1.2	180	718322
	60	1.5	180	718324
	72	1.8	75	718325
	72	1.8	90	22123
	72	1.8	180	718326

### Hose Requirements

C-66-1400  
Oxygen ..... "C" size; Fuel "B" size

### Riding Skid Assembly

C-63 ..... 5279716  
C-66-1400 ..... 2029858

GAS TORCHES

GAS TORCHES



### Victor Machine Torches

Available in two and three hose versions. Two hose torches are available in 4.5 in. (114.3 mm), 10 in. (254.0 mm) and 18 in. (457.2 mm) models, and three hose torches are available in 10 in. (254.0 mm) and 18 in. (457.2 mm) models.

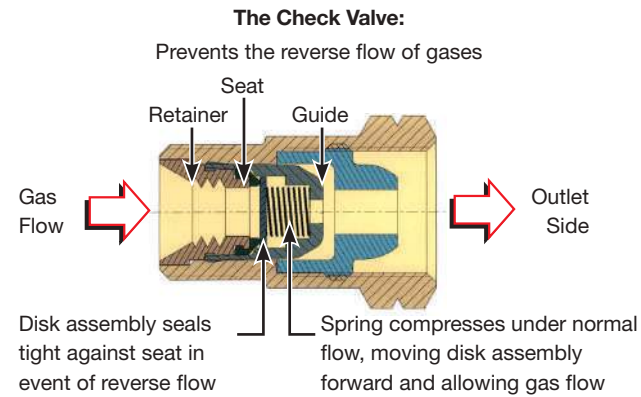

### Straight Cutting Torches & Cutting Machine Reference Guide

Torch Model	Tip Series	Fuel Gas Usage	Cut Capacity
<b>"FC" Models</b>			
ST 2600FC VanGuard	1	Any Fuel Gas	1/8 in. to 8 in. (3.2 to 203.2 mm)
ST 1000FC VanGuard	1	Any Fuel Gas	1/8 in. to 5 in. (3.2 to 127.0 mm)
ST 900FC VanGuard	1	Any Fuel Gas	1/8 in. to 5 in. (3.2 to 127.0 mm)
<b>Machine Torches</b>			
MT 200 (2 Hose)	1	Any Fuel Gas	7 in. (177.8 mm)
MT 300 (3 Hose)	1	Any Fuel Gas	12 in. (304.8 mm)
MT 1065 (3 Hose)	1	Any Fuel Gas	7 in. (177.8 mm)
MT 5 (3 Hose)	1	Any Fuel Gas	7 in. (177.8 mm)

Check Valve Pair Pack



### Tip Type

**BTN** for use with Natural Gas & Propane.

**BTMP** for use with Propylene Gases

(For use with MT200, MT300 Series Machine Cutting Torches)

Length of Bevel	Tip Size	Speed IPM	Oxygen Pressure	Fuel Pressure	Cutting Oxygen Pressure
<b>MT 200 Series</b>					
1	4	10/18	60/75	8/10	-
1.5	4	8/16	60/75	8/10	-
2	4	6/14	60/75	8/10	-
2.5	4	5/12	60/75	8/10	-
3	5	6/11	60/75	8/12	-
3.5	5	5/10	60/75	8/12	-
4	5	4/9	60/75	8/12	-
4.5	5	4/8	60/75	8/12	-
5	6	3/8	65/85	8/15	-
5.5	6	3/7	65/85	8/15	-
6	6	3/6	65/85	8/15	-
<b>MT 300N Series</b>					
1	4	10/18	35/65	10/12	40/60
1.5	4	8/16	35/65	10/12	40/60
2	4	6/14	35/65	10/12	40/60
2.5	4	5/12	35/65	10/12	40/60
3	5	6/11	35/65	10/12	40/65
3.5	5	5/10	35/65	10/12	40/65
4	5	4/9	35/65	10/12	40/65
4.5	5	4/8	35/65	10/12	40/65
5	6	3/8	35/65	10/12	40/75
5.5	6	3/7	35/65	10/12	40/75
6	6	3/6	35/65	10/12	40/75

*Bevels of 30° to 70° are possible on mild steel and most alloy steel without a preheat attachment. High gas withdrawal rates will require manifolding. Consult your gas supplier.*

### VICTOR MACHINE CUTTING TORCHES ARE AVAILABLE IN TWO AND THREE HOSE MODELS.

Three hose torches are high performance "straight through" design that minimizes turbulence and improves cut quality. Accessory reverse flow check valves are supplied for use at the torches inlet connection. All machine torches use Series 1 cutting tips and are supplied with accessory reverse flow check valves to be used on the torch inlet connections.

### MT 300 SERIES

Three Hose



- Cut capacity: 12 in. (304.8 mm)
- Series 1 cutting tips

#### Ordering Information

Part No.	Model No.	Total Length	Barrel Length	Racking Length	Gas
0380-0222	MT 310A	14 in. (355.6 mm)	10 in. (254.0 mm)	7 in. (177.8 mm)	Acetylene*
0380-0220	MT 310N	14 in. (355.6 mm)	10 in. (254.0 mm)	7 in. (177.8 mm)	LP/Natural Gas**
0380-0221	MT 310NV	14 in. (355.6 mm)	10 in. (254.0 mm)	7 in. (177.8 mm)	LP/Natural Gas**
0380-0223	MT 310AV	14 in. (355.6 mm)	10 in. (254.0 mm)	7 in. (177.8 mm)	Acetylene*
0380-0227	MT 318A	22.5 in. (571.5 mm)	18 in. (457.2 mm)	15 in. (381.0 mm)	Acetylene*
0380-0228	MT 318AV	22.5 in. (571.5 mm)	18 in. (457.2 mm)	15 in. (381.0 mm)	Acetylene*
0380-0225	MT 318N	22.5 in. (571.5 mm)	18 in. (457.2 mm)	15 in. (381.0 mm)	LP/Natural Gas**
0380-0226	MT 318NV	22.5 in. (571.5 mm)	18 in. (457.2 mm)	15 in. (381.0 mm)	LP/Natural Gas**

*\*May also be used on other pressurized fuel gases.  
\*\*May also be used on other fuel gases except acetylene.  
Other machine torch models available. Ask for details.  
MT300 torch does NOT come with rack.  
Gear Rack must be ordered separately.*

### MT 200 SERIES

Two Hose



- Cut capacity: 7 in. (177.8 mm)
- Series 1 cutting tips

#### Ordering Information

Part No.	Model No.	Total Length	Barrel Length	Racking Length	Gas
0380-0215	MT 204A	8.5 in. (215.9 mm)	4.5 in. (114.3 mm)	-	Acetylene*
0397-0217	MT 204A***	8.5 in. (215.9 mm)	4.5 in. (114.3 mm)	-	Acetylene*
0380-0217	MT 210A	14 in. (355.6 mm)	10 in. (254.0 mm)	7 in. (177.8 mm)	Acetylene*
0380-0216	MT 210N	14 in. (355.6 mm)	10 in. (254.0 mm)	7 in. (177.8 mm)	LP/Natural Gas**

*\*May also be used on other pressurized fuel gases.  
\*\*May also be used on other fuel gases except acetylene.  
\*\*\*Supplied with rack soldered to barrel.  
Other machine torch models available. Ask for details.  
MT200 torch does NOT come with rack.  
Gear Rack must be ordered separately.*

### MT 5

Three Hose



- Cutting capacity - 7 in. (177.8 mm)
- For use with any fuel gas 2 PSI and above
- Series 1 cutting tips
- Supplied with rack soldered to barrel

#### Ordering Information

Part No.	Model No.	Total Length	Barrel Diameter	Barrel Length	Racking Length	Gas
0380-0208	MT 5	8.5 in. (215.9 mm)	1.38 in. (35.1 mm)	5.38 in. (136.7 mm)	5.38 in. (136.7 mm)	All

### GEAR RACKS



- For use with MT 200 and MT 300 Series cutting torches
- Must be ordered separately

#### Ordering Information

Part No.	Length	Pitch	Cutting Machine	Actual Length
0319-0054	10 in. (254.0 mm) Rack Kit	32	MT 210 & MT 310	7.8 in. (198.1 mm)
0319-0055	18 in. (457.2 mm) Rack Kit	32	MT 318	14.5 in. (368.3 mm)

GAS TORCHES

**Pre-Drilled 1.38" (35.1 mm) Diameter Barrels**  
For three position mounting flexibility

**Accessory Reverse Flow Check Valves**  
Supplied with all machine torches or added operator safety

**Straight Through Design**  
Minimizes turbulence, improves cutting performance

**High Performance Mixer Design**  
Provide optimum performance

**Rugged Brass Torch head and body**  
for maximum strength

**MT 200 Series**  
Two hose model

**MT 300 Series**  
Three hose model

GAS TORCHES



### MT 1065 SERIES

Three Hose

- Cut capacity: 7 in. (177.8 mm)
- For use with all fuel gases
- Series 1 cutting tips
- Multi-torch beveling

#### Ordering Information

Part No.	Model No.	Total Length	Barrel Diameter	Barrel Length	Gas
0399-1065	MT 1065N	8 in. (203.2 mm)	1.25 in. (31.8 mm)	4 in. (101.6 mm)	All
0399-1121	MT 1065A	8 in. (203.2 mm)	1.25 in. (31.8 mm)	4 in. (101.6 mm)	Acetylene

## SECTION & REFERENCE INFORMATION

### Cutting Orifice Reference Chart - Cutting Tip Size

For all standard cutting tips except Series MTH high speed models

000	00	0	1	2	3	4	5	6	7	8	10	12
0.027	0.033	0.041	0.047	0.060	0.071	0.083	0.100	0.121	0.141	0.162	0.185	0.221

Orifice Diameter – inches (Orifice diameters shown actual size)

### Code for Fuel Gases



Acetylene



Propane  
Natural Gas



Propylene

### Preheat Chart for Propylene & LP Tips

Torch Series	Preheat Oxygen (psig)	Preheat Fuel (psig)
MT 200	--	1 psig and up
MT 300	30/35	1 psig and up
ST 2600FC	--	1 psig and up
ST 900FC	--	5 psig and up
ST 1000FC	--	5 psig and up

### Cutting Torches

Handle	Cutting Attachment	Fuel Gas
<b>Cutting Torches</b>		
315FC, H 315FC	CA 2460-90°	All
315FC, H 315FC	CA 2461-75°	All
315FC, H 315FC	CA 2462-180°	All
<b>Straight Torches</b>		
ST 2600FC	--	All
ST 1000FC	--	All
ST 900FC	--	All
*HC 1200C	--	All
<b>Machine Torches</b>		
MT 200	--	A, LP
MT 300	--	A, LP

### Material Thickness – Tip Size

Material Thickness		Tip Size
Inches	mm	
1/8 in.	3.2 mm	000
1/4 in.	6.4 mm	00
3/8 – 1/2 in.	9.5 - 12.7 mm	0
3/4 in.	19.1 mm	1
1 – 1 1/2 in.	25.4 - 38.1 mm	2
2 – 2 1/2 in.	50.8 - 63.5 mm	3
3 in.	76.2 mm	4
4 – 5 in.	102 - 127 mm	5
6 – 8 in.	152 - 203 mm	6*
10 in.	254 mm	7*
12 in.	305 mm	8*

\*For best results, use "High Flow Handles" and 3/8" hose

### Gouging Depth Tip Chart

Approximate Gouge Depth				
Depth of gouge will vary due to angle of tip and cutting pressure.				
Type	Tip Size	Depth of Gouge	O <sub>2</sub> psi	C <sub>2</sub> H <sub>2</sub> psi
118	0	1/8 in. - 1/4 in.	30-45	5-7
	2	1/4 in. - 3/8 in.	30-45	5-7
	8	1/4 in. - 1/2 in.	30-55	6-8
218	4	1/4 in. - 3/4 in.	30-65	8-10
	6	3/8 in. - 1 in.	30-65	10-12



Acetylene

## SERIES 1 ACETYLENE CUTTING TIPS

Series 1 tip style, fuel gas usage and Victor equipment compatibility shown below

Type	Fuel Gas	Application
101	A	<ul style="list-style-type: none"> <li>General purpose</li> <li>Hand and machine torch cutting</li> </ul>
101 <sup>30°</sup>	A	<ul style="list-style-type: none"> <li>General purpose</li> <li>Hand and machine torch cutting 30°, with torch perpendicular</li> </ul>
101-L	A	<ul style="list-style-type: none"> <li>General purpose, extra length tips</li> </ul>
108	A	<ul style="list-style-type: none"> <li>Boiler tube removal</li> <li>Tips are short to insert head and tip inside tube</li> </ul>
112	A	<ul style="list-style-type: none"> <li>Cutting close to bulk heads</li> <li>Hand cutting of rivet heads</li> </ul>
118 Tip (Round)	A	<ul style="list-style-type: none"> <li>Deseaming, scarfing, gouging, weld preparation, removing defective welds, washing rivets</li> </ul>
118 Tip (Sides Cutaway)	A	<ul style="list-style-type: none"> <li>Deseaming, scarfing, gouging, weld preparation, removing defective welds, washing rivets</li> </ul>

Tip packaging is color coded with reference to fuel gas usage. Other special application tips available. Contact Technical Services at 1-800-426-1888



Data compiled using mild steel as test material.

\*Applicable for three hose machine torch only. With a two hose cutting torch, preheat pressure is set by the cutting oxygen.

\*\*For best results use ST 2600FC series torches and 3/8 in. hose when using tip size 6 or larger.

\*\*\*All pressures are measured at the regulator using 25 ft x 1/4 in. hose through tip size 5 and 25 ft x 3/8 in.

\*\*\*\*Oxygen consumption is 1.1 times the acetylene under neutral flame conditions.

**WARNING:** At no time should the withdrawal rate of an individual acetylene cylinder exceed 1/7 of the cylinder contents per hour. If additional flow capacity is required use an acetylene manifold system of sufficient size to supply the necessary volume.



## TIP NUT

FOR SERIES 3 CUTTING TIPS

0309-0003

FOR SERIES 1 CUTTING TIPS

0309-0018

**VICTOR SERIES 1 TYPE 101**

- General purpose
- Hand and machine torch cutting

Metal Thickness	Size	Part No.	Cutting Oxygen (psig) ***	Cutting Oxygen (SCFH)	Preheat Oxygen *(psig)	Preheat Oxygen (SCFH)	Fuel (psig)	Fuel **** (SCFH)	Speed ipm	Kerf Width
1/8 in. (3.2 mm)	000	0330-0003	20 / 25	20 / 25	3 / 5	3 / 5	3 / 5	3 / 5	28 / 32	.04
1/4 in. (6.4 mm)	00	0330-0004	20 / 25	30 / 35	3 / 5	4 / 6	3 / 5	4 / 6	27 / 30	.05
1/4 in. (6.4 mm)	00	0387-0133#	20 / 25	30 / 35	3 / 5	4 / 6	3 / 5	4 / 6	27 / 30	.05
3/8 in. (9.5 mm)	0	0330-0012	25 / 30	55 / 60	3 / 5	5 / 9	3 / 5	5 / 8	24 / 28	.06
3/8 in. (9.5 mm)	0	0387-0134#	25 / 30	55 / 60	3 / 5	5 / 9	3 / 5	5 / 8	24 / 28	.06
1/2 in. (12.7 mm)	0	0330-0012	30 / 35	60 / 65	3 / 6	7 / 11	3 / 5	6 / 10	20 / 24	.06
1/2 in. (12.7 mm)	0	0387-0134#	30 / 35	60 / 65	3 / 6	7 / 11	3 / 5	6 / 10	20 / 24	.06
3/4 in. (19.1 mm)	1	0330-0005	30 / 35	80 / 85	4 / 7	9 / 14	3 / 5	8 / 13	17 / 21	.07
3/4 in. (19.1 mm)	1	0387-0135#	30 / 35	80 / 85	4 / 7	9 / 14	3 / 5	8 / 13	17 / 21	.07
1 in. (25.4 mm)	2	0330-0006	40 / 45	150 / 160	4 / 12	13 / 20	3 / 7	12 / 18	13 / 17	.09
1 in. (25.4 mm)	2	0387-0136#	40 / 45	150 / 160	4 / 12	13 / 20	3 / 7	12 / 18	13 / 17	.09
1 1/2 in. (38.1 mm)	2	0330-0006	40 / 45	150 / 160	4 / 12	13 / 20	3 / 7	12 / 18	13 / 17	.09
1 1/2 in. (38.1 mm)	2	0387-0136#	40 / 45	150 / 160	4 / 12	13 / 20	3 / 7	12 / 18	13 / 17	.09
2 in. (50.8 mm)	3	0330-0002	40 / 45	210 / 225	5 / 14	15 / 24	4 / 9	14 / 22	12 / 15	.11
2 1/2 in. (63.5 mm)	3	0330-0002	45 / 50	225 / 240	5 / 16	18 / 29	4 / 10	16 / 26	10 / 13	.11
3 in. (76.2 mm)	4	0330-0007	40 / 50	270 / 320	6 / 17	20 / 33	5 / 10	18 / 30	9 / 12	.12
4 in. (102 mm)	5	0330-0008	45 / 55	390 / 425	7 / 18	24 / 37	5 / 12	22 / 34	8 / 11	.15
5 in. (127 mm)	5	0330-0008	50 / 55	425 / 450	7 / 20	29 / 41	5 / 13	26 / 38	7 / 9	.15
6 in. (152 mm)	6**	0330-0009	45 / 40	500 / 600	10 / 22	33 / 48	7 / 13	30 / 44	6 / 8	.18
8 in. (203 mm)	6**	0330-0009	45 / 55	500 / 600	10 / 25	37 / 55	7 / 14	34 / 50	5 / 6	.19
10 in. (254 mm)	7**	0330-0013	45 / 55	700 / 850	15 / 30	44 / 62	10 / 15	40 / 56	4 / 5	.34
12 in. (305 mm)	8**	0330-0014	45 / 55	900 / 1000	20 / 35	53 / 68	10 / 15	48 / 62	3 / 5	.41

**G-SERIES SERIES 1 TYPE 101**

Metal Thickness	Size	Part No.	Cutting Oxygen (psig) ***	Cutting Oxygen (SCFH)	Preheat Oxygen *(psig)	Preheat Oxygen (SCFH)	Fuel (psig)	Fuel **** (SCFH)	Speed ipm	Kerf Width
1/8 in. (3.2 mm)	000	CS1101000	20 / 25	20 / 25	3 / 5	3 / 5	3 / 5	3 / 5	28 / 32	.04
1/4 in. (6.4 mm)	00	CS110100	20 / 25	30 / 35	3 / 5	4 / 6	3 / 5	4 / 6	27 / 30	.05
3/8 in. (9.5 mm)	0	CS11010	25 / 30	55 / 60	3 / 5	5 / 9	3 / 5	5 / 8	24 / 28	.06
1/2 in. (12.7 mm)	0	CS11010	30 / 35	60 / 65	3 / 6	7 / 11	3 / 5	6 / 10	20 / 24	.06
3/4 in. (19.1 mm)	1	CS11011	30 / 35	80 / 85	4 / 7	9 / 14	3 / 5	8 / 13	17 / 21	.07
1 in. (25.4 mm)	2	CS11012	35 / 40	140 / 150	4 / 9	11 / 18	3 / 6	10 / 16	15 / 19	.09
1 1/2 in. (38.1 mm)	2	CS11012	40 / 45	150 / 160	4 / 12	13 / 20	3 / 7	12 / 18	13 / 17	.09
2 in. (50.8 mm)	3	CS11013	40 / 45	210 / 225	5 / 14	15 / 24	4 / 9	14 / 22	12 / 15	.11
2 1/2 in. (63.5 mm)	3	CS11013	45 / 50	225 / 240	5 / 16	18 / 29	4 / 10	16 / 26	10 / 13	.11
3 in. (76.2 mm)	4	CS11014	40 / 50	270 / 320	6 / 17	20 / 33	5 / 10	18 / 30	9 / 12	.12
4 in. (102 mm)	5	CS11015	45 / 55	390 / 425	7 / 18	24 / 37	5 / 12	22 / 34	8 / 11	.15
5 in. (127 mm)	5	CS11015	50 / 55	425 / 450	7 / 20	29 / 41	5 / 13	26 / 38	7 / 9	.15
6 in. (152 mm)	6**	CS11016	45 / 40	500 / 600	10 / 22	33 / 48	7 / 13	30 / 44	6 / 8	.18
8 in. (203 mm)	6**	CS11016	45 / 55	500 / 600	10 / 25	37 / 55	7 / 14	34 / 50	5 / 6	.19
10 in. (254 mm)	7**	CS11017	45 / 55	700 / 850	15 / 30	44 / 62	10 / 15	40 / 56	4 / 5	.34
12 in. (305 mm)	8**	CS11018	45 / 55	900 / 1000	20 / 35	53 / 68	10 / 15	48 / 62	3 / 5	.41

**VICTOR SERIES 1 TYPE 101 30°**

- General purpose
- Hand and machine torch cutting 30°, with torch perpendicular

Metal Thickness	Size	Part No.	Cutting Oxygen (psig) ***	Cutting Oxygen (SCFH)	Preheat Oxygen *(psig)	Preheat Oxygen (SCFH)	Acetylene (psig)	Acetylene ****(SCFH)	Speed ipm	Kerf Width
3/8 in. (0.9 mm)	0	0330-0198	25 / 30	55 / 60	3 / 5	5 / 9	3 / 5	5 / 8	24 / 28	.06
1/2 in. (1.2 mm)	0	0330-0198	30 / 35	60 / 65	3 / 6	7 / 11	3 / 5	6 / 10	20 / 24	.06
3/4 in. (1.9 mm)	1	0330-0199	30 / 35	80 / 85	4 / 7	9 / 14	3 / 5	8 / 13	17 / 21	.07
1 in. (2.5 mm)	2	0330-0284	35 / 40	140 / 150	4 / 9	11 / 18	3 / 6	10 / 16	15 / 19	.09

**VICTOR SERIES 1 TYPE 101-L**

- General purpose
- Extra length tips



Metal Thickness	Size	Part No.	Cutting Oxygen (psig) ***	Cutting Oxygen (SCFH)	Preheat Oxygen *(psig)	Preheat Oxygen (SCFH)	Acetylene (psig)	Acetylene ****(SCFH)	Speed ipm	Kerf Width
3 in. (7.6 mm)	4	0330-0531	40 / 50	270 / 320	6 / 17	20 / 33	5 / 10	18 / 30	9 / 12	.12
6 in. (15.2 mm)	6**	0330-0535	45 / 40	500 / 600	10 / 22	33 / 48	7 / 13	30 / 44	6 / 8	.18

**VICTOR SERIES 1 TYPE 108**

- Boiler tube removal
- Tip is short to insert head and tip inside tube

Metal Thickness	Size	Part No.	Cutting Oxygen (psig) ***	Cutting Oxygen (SCFH)	Preheat Oxygen *(psig)	Preheat Oxygen (SCFH)	Acetylene (psig)	Acetylene ****(SCFH)	Speed ipm	Kerf Width
3/8 in. (0.9 mm)	0	0330-0058	25 / 30	55 / 60	3 / 5	5 / 9	3 / 5	5 / 8	24 / 28	.06
1/2 in. (1.2 mm)	0	0330-0058	30 / 35	60 / 65	3 / 6	7 / 11	3 / 5	6 / 10	20 / 24	.06
3/4 in. (1.9 mm)	1	0330-0059	30 / 35	80 / 85	4 / 7	9 / 14	3 / 5	8 / 13	17 / 21	.07
1 in. (2.5 mm)	2	0330-0063	35 / 40	140 / 150	4 / 9	11 / 18	3 / 6	10 / 16	15 / 19	.09
1 1/2 in. (3.8 mm)	2	0330-0063	40 / 45	150 / 160	4 / 12	13 / 20	3 / 7	12 / 18	13 / 17	.09
2 in. (5 mm)	3	0330-0064	40 / 45	210 / 225	5 / 14	15 / 24	4 / 9	14 / 22	12 / 15	.11
2 1/2 in. (6.4 mm)	3	0330-0064	45 / 50	225 / 240	5 / 16	18 / 29	4 / 10	16 / 26	10 / 13	.11
3 in. (7.6 mm)	4	0330-0065	40 / 50	270 / 320	6 / 17	20 / 33	5 / 10	18 / 30	9 / 12	.12

**G-SERIES SERIES 1 TYPE 108**

Metal Thickness	Size	Part No.	Cutting Oxygen (psig) ***	Cutting Oxygen (SCFH)	Preheat Oxygen *(psig)	Preheat Oxygen (SCFH)	Acetylene (psig)	Acetylene ****(SCFH)	Speed ipm	Kerf Width
3/8 in. (0.9 mm)	0	CS11080	25 / 30	55 / 60	3 / 5	5 / 9	3 / 5	5 / 8	24 / 28	.06
1/2 in. (1.2 mm)	0	CS11080	30 / 35	60 / 65	3 / 6	7 / 11	3 / 5	6 / 10	20 / 24	.06
3/4 in. (1.9 mm)	1	CS11081	30 / 35	80 / 85	4 / 7	9 / 14	3 / 5	8 / 13	17 / 21	.07
1 in. (2.5 mm)	2	CS11082	35 / 40	140 / 150	4 / 9	11 / 18	3 / 6	10 / 16	15 / 19	.09
1 1/2 in. (3.8 mm)	2	CS11082	40 / 45	150 / 160	4 / 12	13 / 20	3 / 7	12 / 18	13 / 17	.09
2 in. (5 mm)	3	CS11083	40 / 45	210 / 225	5 / 14	15 / 24	4 / 9	14 / 22	12 / 15	.11
2 1/2 in. (6.4 mm)	3	CS11083	45 / 50	225 / 240	5 / 16	18 / 29	4 / 10	16 / 26	10 / 13	.11
3 in. (7.6 mm)	4	CS11084	40 / 50	270 / 320	6 / 17	20 / 33	5 / 10	18 / 30	9 / 12	.12

Data compiled using mild steel as test material.

\*Applicable for three hose machine torch only. With a two hose cutting torch, preheat pressure is set by the cutting oxygen.

\*\*For best results use ST 2600FC series torches and 3/8 in. hose when using tip size 6 or larger.

\*\*\*All pressures are measured at the regulator using 25 ft x 1/4 in. hose through tip size 5 and 25 ft x 3/8 in. hose for tip size 6 and larger.

\*\*\*\*Oxygen consumption is 1.1 times the acetylene under neutral flame conditions.

**WARNING:** At no time should the withdrawal rate of an individual acetylene cylinder exceed 1/7 of the cylinder contents per hour. If additional flow capacity is required use an acetylene manifold system of sufficient size to supply the necessary volume.

### VICTOR SERIES 1 TYPE 112



- Cutting close to bulk heads
- Hand cutting of rivet heads

Metal Thickness	Size	Part No.	Cutting Oxygen (psig) ***	Cutting Oxygen (SCFH)	Preheat Oxygen * (psig)	Preheat Oxygen (SCFH)	Acetylene (psig)	Acetylene ****(SCFH)	Speed ipm	Kerf Width
1 in. (2.5 mm)	2	0330-0086	35 / 40	140 / 150	4 / 9	11 / 18	3 / 6	10 / 16	15 / 19	.09
1 1/2 in. (3.8 mm)	2	0330-0086	40 / 45	150 / 160	4 / 12	13 / 20	3 / 7	12 / 18	13 / 17	.09

### VICTOR SERIES 1 TYPE 118 ROUND



- Deseaming, scarfing, gouging
- Rivet washing
- Weld preparation

Metal Thickness	Size	Part No.	Cutting Oxygen (psig) ***	Cutting Oxygen (SCFH)	Preheat Oxygen * (psig)	Preheat Oxygen (SCFH)	Acetylene (psig)	Acetylene ****(SCFH)	Speed ipm	Kerf Width
3/8 in. (0.9 mm)	0	0330-0109	25 / 30	55 / 60	3 / 5	5 / 9	3 / 5	5 / 8	24 / 28	.06
1/2 in. (1.2 mm)	0	0330-0109	30 / 35	60 / 65	3 / 6	7 / 11	3 / 5	6 / 10	20 / 24	.06
1 in. (2.5 mm)	2	0330-0113	35 / 40	140 / 150	4 / 9	11 / 18	3 / 6	10 / 16	15 / 19	.09
1 1/2 in. (3.8 mm)	2	0330-0113	40 / 45	150 / 160	4 / 12	13 / 20	3 / 7	12 / 18	13 / 17	.09
3 in. (7.6 mm)	4	0330-0114	40 / 50	270 / 320	6 / 17	20 / 33	5 / 10	18 / 30	9 / 12	.12

### G-SERIES SERIES 1 TYPE 118 (ROUND)

Metal Thickness	Size	Part No.	Cutting Oxygen (psig) ***	Cutting Oxygen (SCFH)	Preheat Oxygen * (psig)	Preheat Oxygen (SCFH)	Acetylene (psig)	Acetylene ****(SCFH)	Speed ipm	Kerf Width
3/8 in. (0.9 mm)	0	CS11180	25 / 30	55 / 60	3 / 5	5 / 9	3 / 5	5 / 8	24 / 28	.06
1/2 in. (1.2 mm)	0	CS11180	30 / 35	60 / 65	3 / 6	7 / 11	3 / 5	6 / 10	20 / 24	.06
1 in. (2.5 mm)	2	CS11182	35 / 40	140 / 150	4 / 9	11 / 18	3 / 6	10 / 16	15 / 19	.09
1 1/2 in. (3.8 mm)	2	CS11182	40 / 45	150 / 160	4 / 12	13 / 20	3 / 7	12 / 18	13 / 17	.09
3 in. (7.6 mm)	4	CS11184	40 / 50	270 / 320	6 / 17	20 / 33	5 / 10	18 / 30	9 / 12	.12

### VICTOR SERIES 1 TYPE 118 (SIDES CUTAWAY)



- Deseaming, scarfing, gouging
- Rivet washing
- Weld preparation

Metal Thickness	Size	Part No.	Cutting Oxygen (psig) ***	Cutting Oxygen (SCFH)	Preheat Oxygen * (psig)	Preheat Oxygen (SCFH)	Acetylene (psig)	Acetylene ****(SCFH)	Speed ipm	Kerf Width
6 in. (15.2 mm)	6**	0330-0115	45 / 40	500 / 600	10 / 22	33 / 48	7 / 13	30 / 44	6 / 8	.18
8 in. (20.3 mm)	6**	0330-0115	45 / 55	500 / 600	10 / 25	37 / 55	7 / 14	34 / 50	5 / 6	.19
12 in. (30.5 mm)	8**	0330-0116	45 / 55	900 / 1000	20 / 35	53 / 68	10 / 15	48 / 62	3 / 5	.41

### G-SERIES SERIES 1 TYPE 118 (SIDES CUTAWAY)

Metal Thickness	Size	Part No.	Cutting Oxygen (psig) ***	Cutting Oxygen (SCFH)	Preheat Oxygen * (psig)	Preheat Oxygen (SCFH)	Acetylene (psig)	Acetylene ****(SCFH)	Speed ipm	Kerf Width
6 in. (15.2 mm)	6**	CS11186	45 / 40	500 / 600	10 / 22	33 / 48	7 / 13	30 / 44	6 / 8	.18
8 in. (20.3 mm)	6**	CS11186	45 / 55	500 / 600	10 / 25	37 / 55	7 / 14	34 / 50	5 / 6	.19
12 in. (30.5 mm)	8**	CS11188	45 / 55	900 / 1000	20 / 35	53 / 68	10 / 15	48 / 62	3 / 5	.41

Data compiled using mild steel as test material.

\*Applicable for three hose machine torch only. With a two hose cutting torch, preheat pressure is set by the cutting oxygen.

\*\*For best results use ST 2600FC series torches and 3/8 in. hose when using tip size 6 or larger.

\*\*\*All pressures are measured at the regulator using 25 ft x 1/4 in. hose through tip size 5 and 25 ft x 3/8 in. hose for tip size 6 and larger.

\*\*\*\*Oxygen consumption is 1.1 times the acetylene under neutral flame conditions.

**WARNING:** At no time should the withdrawal rate of an individual acetylene cylinder exceed 1/7 of the cylinder contents per hour. If additional flow capacity is required use an acetylene manifold system of sufficient size to supply the necessary volume.



## SERIES 1 PROPYLENE CUTTING TIPS

Series 1 tip style, fuel gas usage and Victor equipment compatibility shown below

Type	Fuel Gas	Application
GPP	P	<ul style="list-style-type: none"> <li>■ General purpose</li> <li>■ Hand and machine torch cutting</li> </ul>
HPP	P	<ul style="list-style-type: none"> <li>■ Heavy preheat for scrap, bevel and other heavy preheat requirements</li> </ul>
MTHP	P	<ul style="list-style-type: none"> <li>■ High speed machine cutting through 10" (252 mm)</li> </ul>
303MP	P	<ul style="list-style-type: none"> <li>■ General purpose</li> <li>■ Hand and machine torch cutting</li> </ul>
	P	<ul style="list-style-type: none"> <li>■ High performance</li> <li>■ Bevel cutting</li> </ul>
GTB	P	<ul style="list-style-type: none"> <li>■ Gouging tip (bent)</li> <li>■ Removing welds</li> </ul>
318MP	P	<ul style="list-style-type: none"> <li>■ General purpose</li> <li>■ Gouging and rivet washing</li> </ul>

Tip packaging is color coded with reference to fuel gas usage. Other special application tips available. Contact Technical Services at 1-800-426-1888



### VICTOR SERIES 1 TYPE GPP



- General purpose
- Hand and machine torch cutting

Metal Thickness	Size	Part No.	Cutting Oxygen *** (psig)	Cutting Oxygen (SCFH)	Preheat Oxygen *(psig)	Preheat Oxygen (SCFH)	Fuel (psig)	Fuel **** (SCFH)	Speed ipm	Kerf Width
1/8 in. (3.2 mm)	000	0333-0260	20/25	12/14	REFERENCE PREHEAT CHART ON PAGE 158	23/108	3/5	5/6	24/28	0.04
1/4 in. (6.4 mm)	00	0333-0261	20/25	22/.26		23/108	3/5	5/7	21/25	0.04
3/8 in. (9.5 mm)	0	0333-0262	25/30	45/55		23/108	3/5	8/10	20/24	0.06
3/8 in. (9.5 mm)	0	0387-0154#	25/30	45/55		23/108	3/5	8/10	20/24	0.06
1/2 in. (12.7 mm)	0	0333-0262	30/35	50/55		23/108	3/5	8/10	18/22	0.06
1/2 in. (12.7 mm)	0	0387-0154#	30/35	50/55		23/108	3/5	8/10	18/22	0.06
3/4 in. (19.1 mm)	1	0333-0263	30/35	70/80		23/108	4/6	10/12	15/20	0.08
3/4 in. (19.1 mm)	1	0387-0155#	30/35	70/80		23/108	4/6	10/12	15/20	0.08
1 in. (25.4 mm)	2	0333-0264	35/40	115/125		23/108	4/8	12/15	14/18	0.09
1 in. (25.4 mm)	2	0387-0156#	35/40	115/125		23/108	4/8	12/15	14/18	0.09
1 1/2 in. (38.1 mm)	2	0333-0264	40/45	125/135		23/108	5/9	12/15	12/16	0.09
2 in. (50.8 mm)	3	0333-0265	40/50	150/175		23/108	5/9	14/18	10/14	0.10
2 1/2 in. (63.5 mm)	3	0333-0265	45/50	175/200	23/108	6/10	14/18	9/12	0.10	
3 in. (76.2 mm)	4	0333-0266	45/50	210/250	23/108	8/12	16/20	8/11	0.12	
4 in. (102 mm)	5	0333-0267	45/55	300/360	23/108	8/12	20/30	7/10	0.14	
5 in. (127 mm)	5	0333-0267	50/55	330/360	23/108	8/12	20/30	6/9	0.14	
6 in. (152 mm)	6**	0333-0268	45/55	400/500	23/153	10/15	25/35	5/7	0.17	
8 in. (203 mm)	6**	0333-0268	55/65	450/500	23/153	10/15	25/35	4/6	0.18	
10 in. (254 mm)	7	0333-0269	55/65	450/500	23/153	8/12	25/35	3/5	0.34	
12 in. (305 mm)	8	0333-0270	60/70	450/500	23/153	10/14	25/35	3/4	0.14	

### G-SERIES SERIES 1 TYPE GPP

Metal Thickness	Size	Part No.	Cutting Oxygen *** (psig)	Cutting Oxygen (SCFH)	Preheat Oxygen *(psig)	Preheat Oxygen (SCFH)	Fuel (psig)	Fuel **** (SCFH)	Speed ipm	Kerf Width
1/8 in. (3.2 mm)	000	CSGPP000	20/25	12/14	REFERENCE PREHEAT CHART ON PAGE 158	23/108	3/5	5/6	24/28	0.04
1/4 in. (6.4 mm)	00	CSGPP00	20/25	22/.26		23/108	3/5	5/7	21/25	0.04
3/8 in. (9.5 mm)	0	CSGPP0	25/30	45/55		23/108	3/5	8/10	20/24	0.06
1/2 in. (12.7 mm)	0	CSGPP0	30/35	50/55		23/108	3/5	8/10	18/22	0.06
3/4 in. (19.1 mm)	1	CSGPP1	30/35	70/80		23/108	4/6	10/12	15/20	0.08
1 in. (25.4 mm)	2	CSGPP2	35/40	115/125		23/108	4/8	12/15	14/18	0.09
1 1/2 in. (38.1 mm)	2	CSGPP2	40/45	125/135		23/108	5/9	12/15	12/16	0.09
2 in. (50.8 mm)	3	CSGPP3	40/50	150/175		23/108	5/9	14/18	10/14	0.10
2 1/2 in. (63.5 mm)	3	CSGPP3	45/50	175/200		23/108	6/10	14/18	9/12	0.10
3 in. (76.2 mm)	4	CSGPP4	45/50	210/250		23/108	8/12	16/20	8/11	0.12
4 in. (102 mm)	5	CSGPP5	45/55	300/360		23/108	8/12	20/30	7/10	0.14
5 in. (127 mm)	5	CSGPP5	50/55	330/360		23/108	8/12	20/30	6/9	0.14
6 in. (152 mm)	6**	CSGPP6	45/55	400/500	23/153	10/15	25/35	5/7	0.17	
8 in. (203 mm)	6**	CSGPP6	55/65	450/500	23/153	10/15	25/35	4/6	0.18	
10 in. (254 mm)	7**	CSGPP7	55/65	450/500	23/153	8/12	25/35	3/5	0.34	
12 in. (305 mm)	8**	CSGPP8	60/70	450/500	23/153	10/14	25/35	3/4	0.14	

Data compiled using mild steel as test material.  
 \*Applicable for three hose machine torch only. With a two hose cutting torch, preheat pressure is set by the cutting oxygen.  
 \*\*For best results use ST 2600FC series torches and 3/8 in. hose when using tip size 6 or larger.  
 \*\*\*All pressures are measured at the regulator using 25 ft x 1/4 in. hose through tip size 5 and 25 ft x 3/8 in. hose for tip size 6 and larger.  
 \*\*\*\*Oxygen consumption is 1.1 times the acetylene under neutral flame conditions.

### G-SERIES SERIES 1 TYPE GPP-P (PLATED)



- General purpose
- Two-piece
- Medium preheat

Metal Thickness	Size	Part No.	Cutting Oxygen *** (psig)	Cutting Oxygen (SCFH)	Preheat Oxygen *(psig)	Preheat Oxygen (SCFH)	Fuel (psig)	Fuel **** (SCFH)	Speed ipm	Kerf Width
1/4 in. (6.4 mm)	00	CSGPPP00	20/25	22/26	REFERENCE PREHEAT CHART ON PAGE 158	23/108	3/5	5/7	21/25	0.04
3/8 in. (9.5 mm)	0	CSGPPP0	25/30	45/55		23/108	3/5	8/10	20/24	0.06
1/2 in. (12.7 mm)	0	CSGPPP0	30/35	50/55		23/108	3/5	8/10	18/22	0.06
3/4 in. (19.1 mm)	1	CSGPPP1	30/35	70/80		23/108	4/6	10/12	15/20	0.08
1 in. (25.4 mm)	2	CSGPPP2	35/40	115/125		23/108	4/8	12/15	14/18	0.09
1 1/2 in. (38.1 mm)	2	CSGPPP	40/45	125/135		23/108	5/9	12/15	12/16	0.09
2 in. (50.8 mm)	3	CSGPPP3	40/50	150/175		23/108	5/9	14/18	10/14	0.10
2 1/2 in. (63.5 mm)	3	CSGPPP3	45/50	175/200		23/108	6/10	14/18	9/12	0.10
3 in. (76.2 mm)	4	CSGPPP4	45/50	210/250		23/108	8/12	16/20	8/11	0.12
4 in. (102 mm)	5	CSGPPP5	45/55	300/360		23/108	8/12	20/30	7/10	0.14
5 in. (127 mm)	5	CSGPPP5	50/55	330/360		23/108	8/12	20/30	6/9	0.14
6 in. (152 mm)	6**	CSGPPP6	45/55	400/500		23/153	10/15	25/35	5/7	0.17
8 in. (203 mm)	6**	CSGPPP6	55/65	450/500		23/153	10/15	25/35	4/6	0.18
10 in. (254 mm)	7**	CSGPPP7	55/65	450/500		23/153	8/12	25/35	3/5	0.34

### VICTOR SERIES 1 TYPE HPP



- Heavy preheat
- Scrap and bevel
- Hand and machine cutting

Metal Thickness	Size	Part No.	Cutting Oxygen *** (psig)	Cutting Oxygen (SCFH)	Preheat Oxygen *(psig)	Preheat Oxygen (SCFH)	Fuel (psig)	Fuel **** (SCFH)	Speed ipm	Kerf Width
1/2 in. (12.7 mm)	0	0333-0282	30/35	70/80	REFERENCE PREHEAT CHART ON PAGE 158	44/240	3/5	22/110	18/22	0.06
3/4 in. (19.1 mm)	1	0333-0283	30/35	70/80		44/240	3/6	22/110	15/20	0.08
1 in. (25.4 mm)	2	0333-0284	35/40	115/125		44/240	3/6	22/110	14/18	0.09
1 1/2 in. (38.1 mm)	2	0333-0284	40/45	125/135		44/240	4/8	22/110	12/16	0.09
2 in. (50.8 mm)	3	0333-0285	40/45	150/175		44/240	4/8	22/110	10/14	0.10
2 1/2 in. (63.5 mm)	3	0333-0285	45/50	175/200		44/240	5/9	22/110	9/12	0.10
3 in. (76.2 mm)	4	0333-0286	40/50	210/250		44/240	6/9	22/110	8/11	0.12
4 in. (102 mm)	5	0333-0287	45/55	300/360		44/240	6/9	22/110	7/10	0.14
5 in. (127 mm)	5	0333-0287	50/55	330/360		44/240	6/10	22/110	6/9	0.14
6 in. (152 mm)	6**	0333-0288	45/55	400/500		44/240	6/10	22/110	5/7	0.17
8 in. (203 mm)	6**	0333-0288	55/65	450/500		44/240	8/12	22/110	4/6	0.18
12 in. (305 mm)	8**	0333-0290	60/70	750/850		50/265	10/14	25/120	3/4	0.41
15 in. (381 mm)	10**	0333-0291	45/55	1000/1200		50/265	10/16	25/120	2/4	--
18 in. (457 mm)	12**	0333-0292	45/55	1150/1350		60/290	10/16	30/130	2/3	--

### G-SERIES SERIES 1 TYPE HPP

Metal Thickness	Size	Part No.	Cutting Oxygen *** (psig)	Cutting Oxygen (SCFH)	Preheat Oxygen *(psig)	Preheat Oxygen (SCFH)	Fuel (psig)	Fuel **** (SCFH)	Speed ipm	Kerf Width
3/4 in. (19.1 mm)	1	CSHPP1	30/35	70/80	REFERENCE PREHEAT CHART ON PAGE 158	44/240	3/6	22/110	15/20	0.08
1 in. (25.4 mm)	2	CSHPP2	35/40	115/125		44/240	3/6	22/110	14/18	0.09
1 1/2 in. (38.1 mm)	2	CSHPP2	40/45	125/135		44/240	4/8	22/110	12/16	0.09
2 in. (50.8 mm)	3	CSHPP3	40/45	150/175		44/240	4/8	22/110	10/14	0.10
2 1/2 in. (63.5 mm)	3	CSHPP3	45/50	175/200		44/240	5/9	22/110	9/12	0.10
3 in. (76.2 mm)	4	CSHPP4	40/50	210/250		44/240	6/9	22/110	8/11	0.12
4 in. (102 mm)	5	CSHPP5	45/55	300/360		44/240	6/9	22/110	7/10	0.14
5 in. (127 mm)	5	CSHPP5	50/55	330/360		44/240	6/10	22/110	6/9	0.14
6 in. (152 mm)	6**	CSHPP6	45/55	400/500		44/240	6/10	22/110	5/7	0.17
8 in. (203 mm)	6**	CSHPP6	55/65	450/500		44/240	8/12	22/110	4/6	0.18
10 in. (254 mm)	7**	CSHPP7	55/65	450/500		23/153	5/12	25/35	3/5	0.34
12 in. (305 mm)	8**	CSHPP8	60/70	750/850		50/265	10/14	25/120	3/4	0.41

Data compiled using mild steel as test material.  
 \*Applicable for three hose machine torch only. With a two hose cutting torch, preheat pressure is set by the cutting oxygen.  
 \*\*For best results use ST 2600FC series torches and 3/8 in. hose when using tip size 6 or larger.  
 \*\*\*All pressures are measured at the regulator using 25 ft x 1/4 in. hose through tip size 5 and 25 ft x 3/8 in. hose for tip size 6 and larger.  
 \*\*\*\*Oxygen consumption is 1.1 times the acetylene under neutral flame conditions.

### VICTOR SERIES 1 TYPE MTHP



- High speed machines cutting up to 8 in. (203.2 mm)
- Two-piece
- Medium preheat

Metal Thickness	Size	Part No.	Cutting Oxygen *** (psig)	Cutting Oxygen (SCFH)	Preheat Oxygen * (psig)	Preheat Oxygen (SCFH)	Fuel (psig)	Fuel **** (SCFH)	Speed ipm	Kerf Width
1/4 in. (6.4 mm)	00	0333-0352	85/95	68/75	30/35	23/140	3/5	12/65	23/30	0.05
3/8 in. (9.5 mm)	00	0333-0352	85/95	68/75	30/35	23/140	3/5	12/65	22/29	0.05
1/2 in. (12.7 mm)	0	0333-0353	85/95	110/120	30/35	23/140	3/5	12/65	20/28	0.06
3/4 in. (19.1 mm)	0	0333-0353	85/95	110/120	30/35	23/140	3/5	12/65	18/26	0.06
1 in. (25.4 mm)	1	0333-0354	85/95	145/160	30/35	23/140	3/6	12/65	17/24	0.07
1 1/4 in. (31.75 mm)	1	0333-0354	85/95	145/160	30/35	23/140	3/6	12/65	16/20	0.07
1 1/2 in. (38.1 mm)	1	0333-0354	85/95	145/160	30/35	23/140	3/6	12/65	12/16	0.07
1 1/2 in. (38.1 mm)	2	0333-0355	85/95	230/250	30/35	23/140	3/6	12/65	11/15	0.09
2 in. (50.8 mm)	2	0333-0355	85/95	230/250	30/35	23/140	4/8	12/65	10/13	0.09
2 1/2 in. (63.5 mm)	2	0333-0355	85/95	230/250	30/35	23/140	4/8	12/65	9/11	0.09
3 in. (76.2 mm)	3	0333-0356	85/95	285/320	30/35	23/140	5/11	12/65	7/10	0.11
4 in. (102 mm)	3	0333-0356	85/95	285/320	30/35	23/140	6/13	12/65	6/8	0.11
5 in. (127 mm)	3	0333-0356	85/95	285/320	30/35	23/140	6/13	12/65	5/7	0.11
6 in. (152 mm)	4	0333-0357	85/95	390/450	30/35	23/140	8/14	12/65	5/6	0.14
8 in. (203 mm)	4	0333-0357	85/95	390/450	30/35	23/140	8/14	12/65	4/6	0.14
9 in. (228.6 mm)	5	0333-0358	85/95	670/720	30/35	23/140	10/15	12/65	4/5	0.18
10 in. (254 mm)	5	0333-0358	85/95	670/720	30/35	23/140	10/15	12/65	3/5	0.18

### VICTOR SERIES 1 TYPE 303MP



- General purpose
- Hand and machine torch cutting

Metal Thickness	Size	Part No.	Cutting Oxygen *** (psig)	Cutting Oxygen (SCFH)	Preheat Oxygen * (psig)	Preheat Oxygen (SCFH)	Fuel (psig)	Fuel **** (SCFH)	Speed ipm	Kerf Width
1/4 in. (6.4 mm)	00	0330-0187	20/25	22/26		23/108	3/5	5/7	21/25	0.04
3/8 in. (9.5 mm)	0	0330-0188	25/30	45/55		23/108	3/5	8/10	20/24	0.06
1/2 in. (12.7 mm)	0	0330-0188	30/35	50/55		23/108	3/5	8/10	18/22	0.06
3/4 in. (19.1 mm)	1	0330-0189	30/35	70/80		23/108	4/6	10/12	15/20	0.08
1 in. (25.4 mm)	2	0330-0193	35/40	115/125		23/108	4/8	12/15	14/18	0.09
1 1/2 in. (38.1 mm)	2	0330-0193	40/45	125/135		23/108	5/9	12/15	12/16	0.09
2 in. (50.8 mm)	3	0330-0194	40/45	150/175		23/108	5/9	14/18	10/14	0.10
2 1/2 in. (63.5 mm)	3	0330-0194	45/50	175/200		23/108	6/10	14/18	9/12	0.10
3 in. (76.2 mm)	4	0330-0195	45/50	210/250		23/108	8/12	16/20	8/11	0.12
4 in. (102 mm)	5	0330-0196	45/55	300/360		23/108	8/12	20/30	7/10	0.14
5 in. (127 mm)	5	0330-0196	50/55	330/360		23/108	8/12	20/30	6/9	0.14
6 in. (152 mm)	6**	0330-0197	45/55	400/500		23/153	10/15	25/35	5/7	0.17
8 in. (203 mm)	6**	0330-0197	55/65	450/500		23/153	10/15	25/35	4/6	0.18

### G-SERIES SERIES 1 TYPE 303MP

Metal Thickness	Size	Part No.	Cutting Oxygen *** (psig)	Cutting Oxygen (SCFH)	Preheat Oxygen * (psig)	Preheat Oxygen (SCFH)	Fuel (psig)	Fuel **** (SCFH)	Speed ipm	Kerf Width
3/8 in. (9.5 mm)	0	CS1303MP0	25/30	45/55		23/108	3/5	8/10	20/24	0.06
1/2 in. (12.7 mm)	0	CS1303MP0	30/35	50/55		23/108	3/5	8/10	18/22	0.06
3/4 in. (19.1 mm)	1	CS1303MP1	30/35	70/80		23/108	4/6	10/12	15/20	0.08
1 in. (25.4 mm)	2	CS1303MP2	35/40	115/125		23/108	4/8	12/15	14/18	0.09
1 1/2 in. (38.1 mm)	2	CS1303MP2	40/45	125/135		23/108	5/9	12/15	12/16	0.09
2 in. (50.8 mm)	3	CS1303MP3	40/50	150/175		23/108	5/9	14/18	10/14	0.10
2 1/2 in. (63.5 mm)	3	CS1303MP3	45/50	175/200		23/108	6/10	14/18	9/12	0.10
3 in. (76.2 mm)	4	CS1303MP4	45/50	210/250		23/108	8/12	16/20	8/11	0.12
4 in. (102 mm)	5	CS1303MP5	45/55	300/360		23/108	8/12	20/30	7/10	0.14
5 in. (127 mm)	5	CS1303MP5	50/55	330/360		23/108	8/12	20/30	6/9	0.14
6 in. (152 mm)	6**	CS1303MP6	45/55	400/500		23/153	10/15	25/35	5/7	0.17
8 in. (203 mm)	6**	CS1303MP6	55/65	450/500		23/153	10/15	25/35	4/6	0.18

### VICTOR SERIES 1 TYPE BTMP



- High performance
- Bevel cutting

Metal Thickness	Size	Part No.	Cutting Oxygen *** (psig)	Cutting Oxygen (SCFH)	Preheat Oxygen * (psig)	Preheat Oxygen (SCFH)	Fuel (psig)	Fuel **** (SCFH)	Speed ipm	Kerf Width
1 in. (25.4 mm)	4	0333-0209	60/75	390/450	30/35	23/140	8-10	12/65	10/18	-
1 1/2 in. (38.1 mm)	4	0333-0209	60/75	390/450	30/35	23/140	8-10	12/65	8/16	-
2 in. (50.8 mm)	4	0333-0209	60/75	390/450	30/35	23/140	8-10	12/65	6/14	-
2 1/2 in. (63.5 mm)	4	0333-0209	60/75	390/450	30/35	23/140	8-10	12/65	5/12	-
3 in. (76.2 mm)	5	0333-0210	60/75	670/720	30/35	23/140	8-12	12/65	6/11	-
3 1/2 in. (89 mm)	5	0333-0210	60/75	670/720	30/35	23/140	8-12	12/65	12/65	-
4 in. (102 mm)	5	0333-0210	60/75	670/720	30/35	23/140	8-12	12/65	4/9	-
4 1/2 in. (114.3 mm)	5	0333-0210	60/75	670/720	30/35	23/140	8-12	12/65	4/8	-
5 in. (127 mm)	6	0333-0211	65/85	-	30/35	23/140	8-15	12/65	3/8	-
5 1/2 in. (139.7 mm)	6	0333-0211	65/85	-	30/35	23/140	8-15	12/65	3/7	-
6 in. (152 mm)	6	0333-0211	65/85	-	30/35	23/140	8-15	12/65	3/6	-

Data compiled using a 3 Hose Torch

Data compiled using mild steel as test material.

\*Applicable for three hose machine torch only. With a two hose cutting torch, preheat pressure is set by the cutting oxygen.

\*\*For best results use ST 2600FC series torches and 3/8 in. hose when using tip size 6 or larger.

\*\*\*All pressures are measured at the regulator using 25 ft x 1/4 in. hose through tip size 5 and 25 ft x 3/8 in. hose for tip size 6 and larger.

\*\*\*\*Oxygen consumption is 1.1 times the acetylene under neutral flame conditions.

Data compiled using mild steel as test material.

\*Applicable for three hose machine torch only. With a two hose cutting torch, preheat pressure is set by the cutting oxygen.

\*\*For best results use ST 2600FC series torches and 3/8 in. hose when using tip size 6 or larger.

\*\*\*All pressures are measured at the regulator using 25 ft x 1/4 in. hose through tip size 5 and 25 ft x 3/8 in. hose for tip size 6 and larger.

\*\*\*\*Oxygen consumption is 1.1 times the acetylene under neutral flame conditions.

**VICTOR SERIES 1 TYPE GTB**



- Gouging tip (bent)
- Removing welds

Metal Thickness	Size	Part No.	Cutting Oxygen *** (psig)	Cutting Oxygen (SCFH)	Preheat Oxygen * (psig)	Preheat Oxygen (SCFH)	Fuel (psig)	Fuel **** (SCFH)	Speed ipm	Kerf Width
1/4 - 3/4 in. (6.4 - 19.1 mm)	3	0333-0414	30/65	175/200	30/65	23/108	8/10	14/18	-	-
1/4 - 3/4 in. (6.4 - 19.1 mm)	4	0333-0415	30/65	210/250	30/65	23/108	8/10	16/20	-	-

**VICTOR SERIES 1 TYPE 318MP**



- General purpose
- Gouging and rivet washing
- Medium preheat

Metal Thickness	Size	Part No.	Cutting Oxygen *** (psig)	Cutting Oxygen (SCFH)	Preheat Oxygen * (psig)	Preheat Oxygen (SCFH)	Fuel (psig)	Fuel **** (SCFH)	Speed ipm	Kerf Width
2 in. (50.8 mm)	3	0330-0333	40/45	150/175	REFERENCE PREHEAT CHART ON PAGE 158	23/108	5/9	14/18	10/14	0.10
2 1/2 in. (63.5 mm)	3	0330-0333	45/50	175/200		23/108	6/10	14/18	9/12	0.10
3 in. (76.2 mm)	4	0330-0335	45/50	210/250		23/108	8/12	16/20	8/11	0.12
6 in. (152 mm)	6**	0330-0336	45/55	400/500		23/153	10/15	25/35	5/7	0.17
8 in. (203 mm)	6**	0330-0336	55/65	450/500		23/153	10/15	25/35	4/6	0.18

**G-SERIES SERIES 1 TYPE 318MP**

Metal Thickness	Size	Part No.	Cutting Oxygen *** (psig)	Cutting Oxygen (SCFH)	Preheat Oxygen * (psig)	Preheat Oxygen (SCFH)	Fuel (psig)	Fuel **** (SCFH)	Speed ipm	Kerf Width
1 in. (25.4 mm)	2	CS318MP2	35/40	115/125	REFERENCE PREHEAT CHART ON PAGE 158	44/240	3/6	22/110	14/18	0.09
1 1/2 in. (38.1 mm)	2	CS318MP2	40/45	125/135		44/240	4/8	22/110	12/16	0.09
3 in. (76.2 mm)	4	CS318MP4	40/50	210/250		44/240	6/9	22/110	8/11	0.12
6 in. (152 mm)	6**	CS318MP6	45/55	400/500		44/240	6/10	22/110	5/7	0.17
8 in. (203 mm)	6**	CS318MP6	55/65	450/500		44/240	8/12	22/110	4/6	0.18
12 in. (305 mm)	8**	CS318MP8	60/70	750/850		50/265	10/14	25/120	3/4	0.41



Data compiled using mild steel as test material.

\*Applicable for three hose machine torch only. With a two hose cutting torch, preheat pressure is set by the cutting oxygen.

\*\*For best results use ST 2600FC series torches and 3/8 in. hose when using tip size 6 or larger.

\*\*\*All pressures are measured at the regulator using 25 ft x 1/4 in. hose through tip size 5 and 25 ft x 3/8 in. hose for tip size 6 and larger.

\*\*\*\*Oxygen consumption is 1.1 times the acetylene under neutral flame conditions.



Propane  
Natural Gas

**SERIES 1  
LP CUTTING TIPS**

Series 1 tip style, fuel gas usage and Victor equipment compatibility shown below

Type	Fuel Gas	Application
<b>200</b>	LP	<ul style="list-style-type: none"> <li>■ General purpose</li> <li>■ Hand and machine torch cutting</li> </ul>
<b>207</b>	LP	<ul style="list-style-type: none"> <li>■ Used for "blowing" rivets</li> <li>■ Popular with various railroad applications</li> </ul>
<b>244</b>	LP	<ul style="list-style-type: none"> <li>■ Cutting close to bulk heads</li> <li>■ Rivet cutting</li> </ul>
<b>MCN</b>	LP	<ul style="list-style-type: none"> <li>■ For application requiring extra heavy pre-heat and wide kerf</li> </ul>
<b>GPN</b>	LP	<ul style="list-style-type: none"> <li>■ General purpose</li> <li>■ Hand and machine torch cutting</li> </ul>
<b>MTHN</b>	LP	<ul style="list-style-type: none"> <li>■ High speed machine cutting through 10" (252 mm)</li> </ul>
<b>HPN</b>	LP	<ul style="list-style-type: none"> <li>■ Heavy preheat for scrap, bevel and other heavy preheat requirements</li> </ul>
<b>BTN</b>	LP	<ul style="list-style-type: none"> <li>■ Heavy performance bevel cutting for use with mild steel HSLA, T1 and HV-80</li> </ul>
<b>CSN</b>	LP	<ul style="list-style-type: none"> <li>■ A coarse splined scrap cutting tip for use with natural gas</li> </ul>
<b>GTB</b>	LP	<ul style="list-style-type: none"> <li>■ Gouging tip (bent)</li> <li>■ Removal of welds</li> </ul>

Tip packaging is color coded with reference to fuel gas usage. Other special application tips available. Contact Technical Services at 1-800-426-1888





## VICTOR SERIES 1 TYPE 200



- General purpose
- Hand and machine torch cutting

Metal Thickness	Size	Part No.	Cutting Oxygen *** (psig)	Cutting Oxygen (SCFH)	Preheat Oxygen * (psig)	Preheat Oxygen (SCFH)	Fuel (psig)	Fuel **** (SCFH)	Speed ipm	Kerf Width
3/4 in. (19.1 mm)	1	0330-0144	30/35	70/80	REFERENCE PREHEAT CHART ON PAGE 158	23/108	4/6	10/12	15/20	0.08
1 in. (25.4 mm)	2	0330-0145	35/40	115/125		23/108	4/8	12/15	14/18	0.09
1 1/2 in. (38.1 mm)	2	0330-0145	40/45	125/135		23/108	5/9	12/15	12/16	0.09
2 in. (50.8 mm)	3	0330-0146	40/50	150/175		23/108	5/9	14/18	10/14	0.10
2 1/2 in. (63.5 mm)	3	0330-0146	45/50	175/200		23/108	6/10	14/18	9/12	0.10
3 in. (76.2 mm)	4	0330-0147	45/50	210/250		23/108	8/12	16/20	8/11	0.12
4 in. (102 mm)	5	0330-0148	45/55	300/360		23/108	8/12	20/30	7/10	0.14
5 in. (127 mm)	5	0330-0148	50/55	330/360		23/108	8/12	20/30	6/9	0.14
6 in. (152 mm)	6**	0330-0149	45/55	400/500		23/153	10/15	25/35	5/7	0.17
8 in. (203 mm)	6**	0330-0149	55/65	450/500		23/153	10/15	25/35	4/6	0.18

## VICTOR SERIES 1 TYPE 207



- Used for “blowing” rivets
- Popular with various railroad applications

Metal Thickness	Size	Part No.	Cutting Oxygen *** (psig)	Cutting Oxygen (SCFH)	Preheat Oxygen * (psig)	Preheat Oxygen (SCFH)	Fuel (psig)	Fuel **** (SCFH)	Speed ipm	Kerf Width
3 in. (76.2 mm)	4	0330-0166	40/50	210/250	REFERENCE PREHEAT CHART ON PAGE 158	44/240	6/9	22/110	8/11	0.12

## VICTOR SERIES 1 TYPE 244



- Cutting close to bulk heads
- Rivet cutting

Metal Thickness	Size	Part No.	Cutting Oxygen *** (psig)	Cutting Oxygen (SCFH)	Preheat Oxygen * (psig)	Preheat Oxygen (SCFH)	Fuel (psig)	Fuel **** (SCFH)	Speed ipm	Kerf Width
1 in. (25.4 mm)	2	0330-0344	35/40	115/125	REFERENCE PREHEAT CHART ON PAGE 158	44/240	3/6	22/110	14/18	0.09
1 1/2 in. (38.1 mm)	2	0330-0344	40/45	125/135		44/240	4/8	22/110	12/16	0.09

## VICTOR SERIES 1 TYPE MCN



- Extra heavy preheat
- Wide kerf

Metal Thickness	Size	Part No.	Cutting Oxygen *** (psig)	Cutting Oxygen (SCFH)	Preheat Oxygen * (psig)	Preheat Oxygen (SCFH)	Fuel (psig)	Fuel **** (SCFH)	Speed ipm	Kerf Width
6 in. (152 mm)	6**	0330-0543	45/55	400/500	REFERENCE PREHEAT CHART ON PAGE 158	44/240	6/10	22/110	5/7	0.17
8 in. (203 mm)	6**	0330-0543	55/65	450/500		44/240	8/12	22/110	4/6	0.18

## VICTOR SERIES 1 TYPE GPN



- General purpose
- Hand and machine cutting

Metal Thickness	Size	Part No.	Cutting Oxygen *** (psig)	Cutting Oxygen (SCFH)	Preheat Oxygen * (psig)	Preheat Oxygen (SCFH)	Fuel (psig)	Fuel **** (SCFH)	Speed ipm	Kerf Width
1/8 in. (3.2 mm)	000	0333-0300	20/25	12/14	REFERENCE PREHEAT CHART ON PAGE 158	23/108	3/5	5/6	24/28	0.04
1/4 in. (6.4 mm)	00	0333-0301	20/25	22/26		23/108	3/5	5/7	21/25	0.04
3/8 in. (9.5 mm)	0	0333-0302	25/30	45/55		23/108	3/5	8/10	20/24	0.06
3/8 in. (9.5 mm)	0	0387-0172#	25/30	45/55		23/108	3/5	8/10	20/24	0.06
1/2 in. (12.7 mm)	0	0333-0302	30/35	50/55		23/108	3/5	8/10	18/22	0.06
1/2 in. (12.7 mm)	0	0387-0172#	30/35	50/55		23/108	3/5	8/10	18/22	0.06
3/4 in. (19.1 mm)	1	0333-0303	30/35	70/80		23/108	4/6	10/12	15/20	0.08
3/4 in. (19.1 mm)	1	0387-0173#	30/35	70/80		23/108	4/6	10/12	15/20	0.08
1 in. (25.4 mm)	2	0333-0304	35/40	115/125		23/108	4/8	12/15	14/18	0.09
1 in. (25.4 mm)	2	0387-0174#	35/40	115/125		23/108	4/8	12/15	14/18	0.09
1 1/2 in. (38.1 mm)	2	0333-0304	40/45	125/135		23/108	5/9	12/15	12/16	0.09
1 1/2 in. (38.1 mm)	2	0387-0174#	40/45	125/135		23/108	5/9	12/15	12/16	0.09
2 in. (50.8 mm)	3	0333-0305	40/50	150/175		23/108	5/9	14/18	10/14	0.10
2 1/2 in. (63.5 mm)	3	0333-0305	45/50	175/200		23/108	6/10	14/18	9/12	0.10
3 in. (76.2 mm)	4	0333-0306	45/50	210/250		23/108	8/12	16/20	8/11	0.12
4 in. (102 mm)	5	0333-0307	45/55	300/360		23/108	8/12	20/30	7/10	0.14
5 in. (127 mm)	5	0333-0307	50/55	330/360		23/108	8/12	20/30	6/9	0.14
6 in. (152 mm)	6**	0333-0308	45/55	400/500		23/153	10/15	25/35	5/7	0.17
8 in. (203 mm)	6**	0333-0308	55/65	450/500		23/153	10/15	25/35	4/6	0.18
10 in. (254 mm)	7**	0333-0309	55/65	450/500		23/153	8/12	25/35	3/5	0.34
12 in. (305 mm)	8**	0333-0310	60/70	450/500		23/153	10/14	25/35	3/4	0.41

## G-SERIES SERIES 1 TYPE GPN

Metal Thickness	Size	Part No.	Cutting Oxygen *** (psig)	Cutting Oxygen (SCFH)	Preheat Oxygen * (psig)	Preheat Oxygen (SCFH)	Fuel (psig)	Fuel **** (SCFH)	Speed ipm	Kerf Width
1/8 in. (3.2 mm)	000	CSGPN000	20/25	12/14	REFERENCE PREHEAT CHART ON PAGE 158	23/108	3/5	5/6	24/28	0.04
1/4 in. (6.4 mm)	00	CSGPN00	20/25	22/26		23/108	3/5	5/7	21/25	0.04
3/8 in. (9.5 mm)	0	CSGPN0	25/30	45/55		23/108	3/5	8/10	20/24	0.06
1/2 in. (12.7 mm)	0	CSGPN00	30/35	50/55		23/108	3/5	8/10	18/22	0.06
3/4 in. (19.1 mm)	1	CSGPN1	30/35	70/80		23/108	4/6	10/12	15/20	0.08
1 in. (25.4 mm)	2	CSGPN2	35/40	115/125		23/108	4/8	12/15	14/18	0.09
1 1/2 in. (38.1 mm)	2	CSGPN2	40/45	125/135		23/108	5/9	12/15	12/16	0.09
2 in. (50.8 mm)	3	CSGPN3	40/50	150/175		23/108	5/9	14/18	10/14	0.10
2 1/2 in. (63.5 mm)	3	CSGPN3	45/50	175/200		23/108	6/10	14/18	9/12	0.10
3 in. (76.2 mm)	4	CSGPN4	45/50	210/250		23/108	8/12	16/20	8/11	0.12
4 in. (102 mm)	5	CSGPN5	45/55	300/360		23/108	8/12	20/30	7/10	0.14
5 in. (127 mm)	5	CSGPN5	50/55	330/360		23/108	8/12	20/30	6/9	0.14
6 in. (152 mm)	6**	CSGPN6	45/55	400/500		23/153	10/15	25/35	5/7	0.17
8 in. (203 mm)	6**	CSGPN6	55/65	450/500		23/153	10/15	25/35	4/6	0.18
10 in. (254 mm)	7**	CSGPN7	55/65	450/500		23/153	8/12	25/35	3/5	0.34
12 in. (305 mm)	8**	CSGPN8	60/70	450/500		23/153	10/14	25/35	3/4	0.41

Data compiled using mild steel as test material.

\*Applicable for three hose machine torch only. With a two hose cutting torch, preheat pressure is set by the cutting oxygen.

\*\*For best results use ST 2600FC series torches and 3/8 in. hose when using tip size 6 or larger.

\*\*\*All pressures are measured at the regulator using 25 ft x 1/4 in. hose through tip size 5 and 25 ft x 3/8 in. hose for tip size 6 and larger.

\*\*\*\*Oxygen consumption is 1.1 times the acetylene under neutral flame conditions.

Data compiled using mild steel as test material.

\*Applicable for three hose machine torch only. With a two hose cutting torch, preheat pressure is set by the cutting oxygen.

\*\*For best results use ST 2600FC series torches and 3/8 in. hose when using tip size 6 or larger.

\*\*\*All pressures are measured at the regulator using 25 ft x 1/4 in. hose through tip size 5 and 25 ft x 3/8 in. hose for tip size 6 and larger.

\*\*\*\*Oxygen consumption is 1.1 times the acetylene under neutral flame conditions.

**G-SERIES SERIES 1 TYPE GPN (PLATED)**



- General purpose
- Hand and machine cutting
- Two-piece
- Medium preheat

Metal Thickness	Size	Part No.	Cutting Oxygen *** (psig)	Cutting Oxygen (SCFH)	Preheat Oxygen * (psig)	Preheat Oxygen (SCFH)	Fuel (psig)	Fuel **** (SCFH)	Speed ipm	Kerf Width
1/8 in. (3.2 mm)	000	CSGPNP000	20/25	12/14	REFERENCE PREHEAT CHART ON PAGE 158	23/108	3/5	5/6	24/28	0.04
1/4 in. (6.4 mm)	00	CSGPNP00	20/25	22/26		23/108	3/5	5/7	21/25	0.04
3/8 in. (9.5 mm)	0	CSGPNP0	25/30	45/55		23/108	3/5	8/10	20/24	0.06
1/2 in. (12.7 mm)	0	CSGPNP0	30/35	50/55		23/108	3/5	8/10	18/22	0.06
3/4 in. (19.1 mm)	1	CSGPNP1	30/35	70/80		23/108	4/6	10/12	15/20	0.08
1 in. (25.4 mm)	2	CSGPNP2	35/40	115/125		23/108	4/8	12/15	14/18	0.09
1 1/2 in. (38.1 mm)	2	CSGPNP2	40/45	125/135		23/108	5/9	12/15	12/16	0.09
2 in. (50.8 mm)	3	CSGPNP3	40/50	150/175		23/108	5/9	14/18	10/14	0.10
2 1/2 in. (63.5 mm)	3	CSGPNP3	45/50	175/200		23/108	6/10	14/18	9/12	0.10
3 in. (76.2 mm)	4	CSGPNP4	45/50	210/250		23/108	8/12	16/20	8/11	0.12
4 in. (102 mm)	5	CSGPNP5	45/55	300/360		23/108	8/12	20/30	7/10	0.14
5 in. (127 mm)	5	CSGPNP6	50/55	330/360		23/108	8/12	20/30	6/9	0.14
6 in. (152 mm)	6**	CSGPNP6	45/55	400/500		23/153	10/15	25/35	5/7	0.17
8 in. (203 mm)	6**	CSGPNP6	55/65	450/500		23/153	10/15	25/35	4/6	0.18
10 in. (254 mm)	7**	CSGPNP7	55/65	450/500		23/153	8/12	25/35	3/5	0.34
12 in. (305 mm)	8**	CSGPNP8	60/70	450/500		23/153	10/14	25/35	3/4	0.41

**VICTOR SERIES 1 TYPE MTHN**



- High speed machine cutting through 10 in. (252 mm)

Metal Thickness	Size	Part No.	Cutting Oxygen *** (psig)	Cutting Oxygen (SCFH)	Preheat Oxygen * (psig)	Preheat Oxygen (SCFH)	Fuel (psig)	Fuel **** (SCFH)	Speed ipm	Kerf Width
1/4 in. (6.4 mm)	00	0333-0363	85/95	68/75	30/35	23/140	3/5	12/65	23/30	0.05
3/8 in. (9.5 mm)	00	0333-0363	85/95	68/75	30/35	23/140	3/5	12/65	22/29	0.05
1/2 in. (12.7 mm)	0	0333-0364	85/95	110/120	30/35	23/140	3/5	12/65	20/28	0.06
3/4 in. (19.1 mm)	0	0333-0364	85/95	110/120	30/35	23/140	3/5	12/65	18/26	0.06
1 in. (25.4 mm)	1	0333-0365	85/95	145/160	30/35	23/140	3/6	12/65	17/24	0.07
1 1/4 in. (31.75 mm)	1	0333-0365	85/95	145/160	30/35	23/140	3/6	12/65	16/20	0.07
1 1/2 in. (38.1 mm)	1	0333-0365	85/95	145/160	30/35	23/140	3/6	12/65	12/16	0.07
2 in. (50.8 mm)	2	0333-0366	85/95	230/250	30/35	23/140	3/6	12/65	11/15	0.09
2 1/2 in. (63.5 mm)	2	0333-0366	85/95	230/250	30/35	23/140	4/8	12/65	10/13	0.09
3 in. (76.2 mm)	2	0333-0366	85/95	230/250	30/35	23/140	4/8	12/65	9/11	0.09
4 in. (102 mm)	3	0333-0367	85/95	285/320	30/35	23/140	5/11	12/65	7/10	0.11
5 in. (127 mm)	3	0333-0367	85/95	285/320	30/35	23/140	6/13	12/65	6/8	0.11
6 in. (152 mm)	3	0333-0367	85/95	285/320	30/35	23/140	6/13	12/65	5/7	0.11
7 in. (177.8 mm)	4	0333-0368	85/95	390/450	30/35	23/140	8/14	12/65	5/6	0.14
8 in. (203 mm)	4	0333-0368	85/95	390/450	30/35	23/140	8/14	12/65	4/6	0.14
9 in. (228.6 mm)	5	0333-0369	85/95	670/720	30/35	23/140	10/15	12/65	4/5	0.18
10 in. (254 mm)	5	0333-0369	85/95	670/720	30/35	23/140	10/15	12/65	3/5	0.18
—	6**	0333-0370	85/95	—	30/35	23/140	10/15	12/65	—	—
—	8**	0333-0371	85/95	—	30/35	23/140	10/15	12/65	—	—

**G-SERIES SERIES 1 TYPE MTHN**



- High speed machine cutting
- Two-piece

Metal Thickness	Size	Part No.	Cutting Oxygen *** (psig)	Cutting Oxygen (SCFH)	Preheat Oxygen * (psig)	Preheat Oxygen (SCFH)	Fuel (psig)	Fuel **** (SCFH)	Speed ipm	Kerf Width
1/4 in. (6.4 mm)	00	CSMTHN00	85/95	68/75	30/35	23/140	3/5	12/65	23/30	0.05
3/8 in. (9.5 mm)	00	CSMTHN00	85/95	68/75	30/35	23/140	3/5	12/65	22/29	0.05
1/2 in. (12.7 mm)	0	CSMTHN0	85/95	110/120	30/35	23/140	3/5	12/65	20/28	0.06
3/4 in. (19.1 mm)	0	CSMTHN0	85/95	110/120	30/35	23/140	3/5	12/65	18/26	0.06
1 in. (25.4 mm)	1	CSMTHN1	85/95	145/160	30/35	23/140	3/6	12/65	17/24	0.07
1 1/4 in. (31.75 mm)	1	CSMTHN1	85/95	145/160	30/35	23/140	3/6	12/65	16/20	0.07
1 1/2 in. (38.1 mm)	1	CSMTHN1	85/95	145/160	30/35	23/140	3/6	12/65	12/16	0.07
2 in. (50.8 mm)	2	CSMTHN2	85/95	230/250	30/35	23/140	3/6	12/65	11/15	0.09
2 1/2 in. (63.5 mm)	2	CSMTHN2	85/95	230/250	30/35	23/140	4/8	12/65	10/13	0.09
3 in. (76.2 mm)	2	CSMTHN2	85/95	230/250	30/35	23/140	4/8	12/65	9/11	0.09
4 in. (102 mm)	3	CSMTHN3	85/95	285/320	30/35	23/140	5/11	12/65	7/10	0.11
5 in. (127 mm)	3	CSMTHN3	85/95	285/320	30/35	23/140	6/13	12/65	6/8	0.11
6 in. (152 mm)	3	CSMTHN3	85/95	285/320	30/35	23/140	6/13	12/65	5/7	0.11
7 in. (177.8 mm)	4	CSMTHN4	85/95	390/450	30/35	23/140	8/14	12/65	5/6	0.14
8 in. (203 mm)	4	CSMTHN4	85/95	390/450	30/35	23/140	8/14	12/65	4/6	0.14
9 in. (228.6 mm)	5	CSMTHN5	85/95	670/720	30/35	23/140	10/15	12/65	4/5	0.18
10 in. (254 mm)	5	CSMTHN5	85/95	670/720	30/35	23/140	10/15	12/65	3/5	0.18
—	6**	CSMTHN6	85/95	—	30/35	23/140	10/15	12/65	—	—

**VICTOR SERIES 1 TYPE HPN**



- Heavy preheat
- Strap and bevel

Metal Thickness	Size	Part No.	Cutting Oxygen *** (psig)	Cutting Oxygen (SCFH)	Preheat Oxygen * (psig)	Preheat Oxygen (SCFH)	Fuel (psig)	Fuel **** (SCFH)	Speed ipm	Kerf Width
1/2 in. (12.7 mm)	0	0333-0322	30/35	70/80	REFERENCE PREHEAT CHART ON PAGE 158	44/240	3/5	22/110	18/22	0.06
3/4 in. (19.1 mm)	1	0333-0323	30/35	70/80		44/240	3/6	22/110	15/20	0.08
1 in. (25.4 mm)	2	0333-0324	35/40	115/125		44/240	3/6	22/110	14/18	0.09
1 1/2 in. (38.1 mm)	2	0333-0324	40/45	125/135		44/240	4/8	22/110	12/16	0.09
2 in. (50.8 mm)	3	0333-0325	40/45	150/175		44/240	4/8	22/110	10/14	0.10
2 1/2 in. (63.5 mm)	3	0333-0325	45/50	175/200		44/240	5/9	22/110	9/12	0.10
3 in. (76.2 mm)	4	0333-0326	40/50	210/250		44/240	6/9	22/110	8/11	0.12
4 in. (102 mm)	5	0333-0327	45/55	300/360		44/240	6/9	22/110	7/10	0.14
5 in. (127 mm)	5	0333-0327	50/55	330/360		44/240	6/10	22/110	6/9	0.14
6 in. (152 mm)	6**	0333-0328	45/55	400/500		44/240	6/10	22/110	5/7	0.17
8 in. (203 mm)	6**	0333-0328	55/65	450/500		44/240	8/12	22/110	4/6	0.18
12 in. (305 mm)	8**	0333-0330	60/70	750/850		50/265	10/14	25/120	3/4	0.41
15 in. (381 mm)	10**	0333-0331	45/55	1000/1200		50/265	10/16	25/120	2/4	—
18 in. (457.2 mm)	12**	0333-0332	45/55	1150/1350		60/290	10/16	30/130	2/3	—

Data compiled using mild steel as test material.

\*Applicable for three hose machine torch only. With a two hose cutting torch, preheat pressure is set by the cutting oxygen.

\*\*For best results use ST 2600FC series torches and 3/8 in. hose when using tip size 6 or larger.

\*\*\*All pressures are measured at the regulator using 25 ft x 1/4 in. hose through tip size 5 and 25 ft x 3/8 in. hose for tip size 6 and larger.

\*\*\*\*Oxygen consumption is 1.1 times the acetylene under neutral flame conditions.

Data compiled using mild steel as test material.

\*Applicable for three hose machine torch only. With a two hose cutting torch, preheat pressure is set by the cutting oxygen.

\*\*For best results use ST 2600FC series torches and 3/8 in. hose when using tip size 6 or larger.

\*\*\*All pressures are measured at the regulator using 25 ft x 1/4 in. hose through tip size 5 and 25 ft x 3/8 in. hose for tip size 6 and larger.

\*\*\*\*Oxygen consumption is 1.1 times the acetylene under neutral flame conditions.

### G-SERIES SERIES 1 TYPE HPN



- Hand and machine torch cutting
- Heavy preheat

Metal Thickness	Size	Part No.	Cutting Oxygen *** (psig)	Cutting Oxygen (SCFH)	Preheat Oxygen * (psig)	Preheat Oxygen (SCFH)	Fuel (psig)	Fuel **** (SCFH)	Speed ipm	Kerf Width
3/4 in. (19.1 mm)	1	CSHPN1	30/35	70/80	REFERENCE PREHEAT CHART ON PAGE 158	44/240	3/6	22/110	15/20	0.08
1 in. (25.4 mm)	2	CSMTHN2	35/40	115/125		44/240	3/6	22/110	14/18	0.09
1 1/2 in. (38.1 mm)	2	CSMTHN2	40/45	125/135		44/240	4/8	22/110	12/16	0.09
2 in. (50.8 mm)	3	CSMTHN3	40/45	150/175		44/240	4/8	22/110	10/14	0.10
2 1/2 in. (63.5 mm)	3	CSMTHN3	45/50	175/200		44/240	5/9	22/110	9/12	0.10
3 in. (76.2 mm)	4	CSMTHN4	40/50	210/250		44/240	6/9	22/110	8/11	0.12
4 in. (102 mm)	5	CSMTHN5	45/55	300/360		44/240	6/9	22/110	7/10	0.14
5 in. (127 mm)	5	CSMTHN5	50/55	330/360		44/240	6/10	22/110	6/9	0.14
6 in. (152 mm)	6**	CSMTHN6	45/55	400/500		44/240	6/10	22/110	5/7	0.17
8 in. (203 mm)	6**	CSMTHN6	55/65	450/500		44/240	8/12	22/110	4/6	0.18
10 in. (254 mm)	7	CSMTHN7	55/65	450/500		23/153	8/12	25/35	3/5	0.34
12 in. (305 mm)	8**	CSMTHN8	60/70	750/850		50/265	10/14	25/120	3/4	0.41
15 in. (381 mm)	10**	CSMTHN10	45/55	1000/1200		50/265	10/16	25/120	2/4	–
18 in. (457.2 mm)	12**	CSMTHN12	45/55	1150/1350		60/290	10/16	30/130	2/3	–

### VICTOR SERIES 1 TYPE BTN



- Heavy performance bevel cutting for use with mild steel
- HSLA, T1 and HY-80

Metal Thickness	Size	Part No.	Cutting Oxygen *** (psig)	Cutting Oxygen (SCFH)	Preheat Oxygen * (psig)	Preheat Oxygen (SCFH)	Fuel (psig)	Fuel **** (SCFH)	Speed ipm	Kerf Width
1 in. (25.4 mm)	4	0333-0206	60/75	390/450	30/35	23/140	8-10	12/65	10/18	–
1 1/2 in. (38.1 mm)	4	0333-0206	60/75	390/450	30/35	23/140	8-10	12/65	8/16	–
2 in. (50.8 mm)	4	0333-0206	60/75	390/450	30/35	23/140	8-10	12/65	6/14	–
2 1/2 in. (63.5 mm)	4	0333-0206	60/75	390/450	30/35	23/140	8-10	12/65	5/12	–
3 in. (76.2 mm)	5	0333-0207	60/75	670/720	30/35	23/140	8-12	12/65	6/11	–
3 1/2 in. (89 mm)	5	0333-0207	60/75	670/720	30/35	23/140	8-12	12/65	12/65	–
4 in. (102 mm)	5	0333-0207	60/75	670/720	30/35	23/140	8-12	12/65	4/9	–
4 1/2 in. (114.3 mm)	5	0333-0207	60/75	670/720	30/35	23/140	8-12	12/65	4/8	–
5 in. (127 mm)	6	0333-0208	65/85	–	30/35	23/140	8-15	12/65	3/8	–
5 1/2 in. (139.7 mm)	6	0333-0208	65/85	–	30/35	23/140	8-15	12/65	3/7	–
6 in. (152 mm)	6	0333-0208	65/85	–	30/35	23/140	8-15	12/65	3/6	–

Data compiled using a 3 Hose Torch

### VICTOR SERIES 1 TYPE CSN



- A course splined scrap cutting tip
- Use with natural gas

Metal Thickness	Size	Part No.	Cutting Oxygen *** (psig)	Cutting Oxygen (SCFH)	Preheat Oxygen * (psig)	Preheat Oxygen (SCFH)	Fuel (psig)	Fuel **** (SCFH)	Speed ipm	Kerf Width
12 in. (305 mm)	8	0333-0411	60/70	750/850	REFERENCE PREHEAT CHART ON PAGE 158	50/265	10/14	25/120	3/4	0.41

Data compiled using mild steel as test material.

\*Applicable for three hose machine torch only. With a two hose cutting torch, preheat pressure is set by the cutting oxygen.

\*\*For best results use ST 2600FC series torches and 3/8 in. hose when using tip size 6 or larger.

\*\*\*All pressures are measured at the regulator using 25 ft x 1/4 in. hose through tip size 5 and 25 ft x 3/8 in. hose for tip size 6 and larger.

\*\*\*\*Oxygen consumption is 1.1 times the acetylene under neutral flame conditions.

### SERIES 3 - CUTTING TIPS

Series 3 tip style, fuel gas usage and Victor equipment compatibility shown below.

#### Cutting Torches

Handle	Cutting Attachment	Fuel Gas
<b>Heavy Duty</b>		
315FC	CA 2460-90°	All
<b>Medium Duty</b>		
100FC	CA 1350-90°, CA 1351-75°, CA 1352-180°	All
<b>Light Duty</b>		
J-40	CA 1260-90°	All
<b>Straight Torches</b>		
CST 800FC	–	All

#### Material Thickness - Tip Size

Material Thickness		Tip Size
Inches	mm	
1/8 in.	3.2 mm	000
1/4 in.	6.4 mm	00
3/8 in. – 1/2 in.	9.5 - 12.7 mm	0
3/4 in.	19.1 mm	1
1 in. – 1 1/2 in.	25.4 - 38.1 mm	2
2 in. – 2 1/2 in.	50.8 - 63.5 mm	3
3 in.	76.2 mm	4
4 in. – 5 in.	102 - 127 mm	5

### SERIES 3 - ACETYLENE CUTTING TIPS

#### VICTOR SERIES 3 TYPE 101



- General purpose
- Hand and machine torch cutting

Metal Thickness	Size	Part No.	Cutting Oxygen *** (psig)	Cutting Oxygen (SCFH)	Preheat Oxygen * (psig)	Preheat Oxygen (SCFH)	Acetylene (psig)	Acetylene ****(SCFH)	Speed ipm	Kerf Width
1/8 in. (3.2 mm)	000	0331-0002	20 / 25	20 / 25	3 / 5	3 / 5	3 / 5	3 / 5	28 / 32	.04
1/4 in. (6.4 mm)	00	0331-0009	20 / 25	30 / 35	3 / 5	4 / 6	3 / 5	4 / 6	27 / 30	.05
1/4 in. (6.4 mm)	00	0387-0144#	20 / 25	30 / 35	3 / 5	4 / 6	3 / 5	4 / 6	27 / 30	.05
3/8 in. (9.5 mm)	0	0331-0013	25 / 30	55 / 60	3 / 5	5 / 9	3 / 5	5 / 8	24 / 28	.06
3/8 in. (9.5 mm)	0	0387-0145#	25 / 30	55 / 60	3 / 5	5 / 9	3 / 5	5 / 8	24 / 28	.06
1/2 in. (12.7 mm)	0	0331-0013	30 / 35	60 / 65	3 / 6	7 / 11	3 / 5	6 / 10	20 / 24	.06
1/2 in. (12.7 mm)	0	0387-0145#	30 / 35	60 / 65	3 / 6	7 / 11	3 / 5	6 / 10	20 / 24	.06
3/4 in. (19.1 mm)	1	0331-0014	30 / 35	80 / 85	4 / 7	9 / 14	3 / 5	8 / 13	17 / 21	.07
3/4 in. (19.1 mm)	1	0387-0146#	30 / 35	80 / 85	4 / 7	9 / 14	3 / 5	8 / 13	17 / 21	.07
1 in. (25.4 mm)	2	0331-0015	35 / 40	140 / 150	4 / 9	11 / 18	3 / 6	10 / 16	15 / 19	.09
1 in. (25.4 mm)	2	0387-0147#	35 / 40	140 / 150	4 / 9	11 / 18	3 / 6	10 / 16	15 / 19	.09
1 1/2 in. (38.1 mm)	2	0331-0015	40 / 45	150 / 160	4 / 12	13 / 20	3 / 7	12 / 18	13 / 17	.09
1 1/2 in. (38.1 mm)	2	0387-0147#	40 / 45	150 / 160	4 / 12	13 / 20	3 / 7	12 / 18	13 / 17	.09
2 in. (50.8 mm)	3	0331-0016	40 / 45	210 / 225	5 / 14	15 / 24	4 / 9	14 / 22	12 / 15	.11
2 1/2 in. (63.5 mm)	3	0331-0016	45 / 50	225 / 240	5 / 16	18 / 29	4 / 10	16 / 26	10 / 13	.11
3 in. (76.2 mm)	4	0331-0017	40 / 50	270 / 320	6 / 17	20 / 33	5 / 10	18 / 30	9 / 12	.12
4 in. (102 mm)	5	0331-0018	45 / 55	390 / 425	7 / 18	24 / 37	5 / 12	22 / 34	8 / 11	.15
5 in. (127 mm)	5	0331-0018	50 / 55	425 / 450	7 / 20	29 / 41	5 / 13	26 / 38	7 / 9	.15

#### G-SERIES SERIES 3 TYPE 101

Metal Thickness	Size	Part No.	Cutting Oxygen *** (psig)	Cutting Oxygen (SCFH)	Preheat Oxygen * (psig)	Preheat Oxygen (SCFH)	Acetylene (psig)	Acetylene ****(SCFH)	Speed ipm	Kerf Width
1/8 in. (3.2 mm)	000	CS3101000	20 / 25	20 / 25	3 / 5	3 / 5	3 / 5	3 / 5	28 / 32	.04
1/4 in. (6.4 mm)	00	CS310100	20 / 25	30 / 35	3 / 5	4 / 6	3 / 5	4 / 6	27 / 30	.05
3/8 in. (9.5 mm)	0	CS31010	25 / 30	55 / 60	3 / 5	5 / 9	3 / 5	5 / 8	24 / 28	.06
1/2 in. (12.7 mm)	0	CS31010	30 / 35	60 / 65	3 / 6	7 / 11	3 / 5	6 / 10	20 / 24	.06
3/4 in. (19.1 mm)	1	CS31011	30 / 35	80 / 85	4 / 7	9 / 14	3 / 5	8 / 13	17 / 21	.07
1 in. (25.4 mm)	2	CS31012	35 / 40	140 / 150	4 / 9	11 / 18	3 / 6	10 / 16	15 / 19	.09
1 1/2 in. (38.1 mm)	2	CS31012	40 / 45	150 / 160	4 / 12	13 / 20	3 / 7	12 / 18	13 / 17	.09
2 in. (50.8 mm)	3	CS31013	40 / 45	210 / 225	5 / 14	15 / 24	4 / 9	14 / 22	12 / 15	.11
2 1/2 in. (63.5 mm)	3	CS31013	45 / 50	225 / 240	5 / 16	18 / 29	4 / 10	16 / 26	10 / 13	.11
3 in. (76.2 mm)	4	CS31014	40 / 50	270 / 320	6 / 17	20 / 33	5 / 10	18 / 30	9 / 12	.12
4 in. (102 mm)	5	CS31015	45 / 55	390 / 425	7 / 18	24 / 37	5 / 12	22 / 34	8 / 11	.15
5 in. (127 mm)	5	CS31015	50 / 55	425 / 450	7 / 20	29 / 41	5 / 13	26 / 38	7 / 9	.15

Data compiled using mild steel as test material.

\*Applicable for three hose machine torch only. With a two hose cutting torch, preheat pressure is set by the cutting oxygen.

\*\*For best results use ST 2600FC series torches and 3/8 in. hose when using tip size 6 or larger.

\*\*\*All pressures are measured at the regulator using 25 ft x 1/4 in. hose through tip size 5 and 25 ft x 3/8 in. hose for tip size 6 and larger.

\*\*\*\*Oxygen consumption is 1.1 times the acetylene under neutral flame conditions.

**WARNING:** At no time should the withdrawal rate of an individual acetylene cylinder exceed 1/7 of the cylinder contents per hour. If additional flow capacity is required use an acetylene manifold system of sufficient size to supply the necessary volume.

### VICTOR SERIES 3 TYPE 118 (ROUND)



- Deseaming, scarfing, gouging
- Rivet washing
- Weld preparation

Metal Thickness	Size	Part No.	Cutting Oxygen *** (psig)	Cutting Oxygen (SCFH)	Preheat Oxygen * (psig)	Preheat Oxygen (SCFH)	Acetylene (psig)	Acetylene ****(SCFH)	Speed ipm	Kerf Width
1 in. (25.4 mm)	2	0331-0035	35 / 40	140 / 150	4 / 9	11 / 18	3 / 6	10 / 16	15 / 19	.09
1 1/2 in. (38.1 mm)	2	0331-0035	40 / 45	150 / 160	4 / 12	13 / 20	3 / 7	12 / 18	13 / 17	.09

### G-SERIES SERIES 3 TYPE 118 (ROUND)

Metal Thickness	Size	Part No.	Cutting Oxygen *** (psig)	Cutting Oxygen (SCFH)	Preheat Oxygen * (psig)	Preheat Oxygen (SCFH)	Acetylene (psig)	Acetylene ****(SCFH)	Speed ipm	Kerf Width
3/8 in. (9.5 mm)	0	CS31180	25 / 30	55 / 60	3 / 5	5 / 9	3 / 5	5 / 8	24 / 28	.06
1/2 in. (12.7 mm)	0	CS31180	30 / 35	60 / 65	3 / 6	7 / 11	3 / 5	6 / 10	20 / 24	.06
1 in. (25.4 mm)	2	CS31181	35 / 40	140 / 150	4 / 9	11 / 18	3 / 6	10 / 16	15 / 19	.09
1 1/2 in. (38.1 mm)	2	CS31181	40 / 45	150 / 160	4 / 12	13 / 20	3 / 7	12 / 18	13 / 17	.09

## SERIES 3 – PROPYLENE CUTTING TIPS

### VICTOR SERIES 3 TYPE GPP



- General purpose
- Hand and machine torch cutting

Metal Thickness	Size	Part No.	Cutting Oxygen *** (psig)	Cutting Oxygen (SCFH)	Preheat Oxygen * (psig)	Preheat Oxygen (SCFH)	Acetylene (psig)	Acetylene ****(SCFH)	Speed ipm	Kerf Width
1/4 in. (6.4 mm)	00	0333-0389	20/25	22/26	REFERENCE PREHEAT CHART ON PAGE 158	23/108	3/5	5/7	21/25	0.04
3/8 in. (9.5 mm)	0	0333-0390	25/30	45/55		23/108	3/5	8/10	20/24	0.06
1/2 in. (12.7 mm)	0	0333-0390	30/35	50/55		23/108	3/5	8/10	18/22	0.06
3/4 in. (19.1 mm)	1	0333-0391	30/35	70/80		23/108	4/6	10/12	15/20	0.08
1 in. (25.4 mm)	2	0333-0392	35/40	115/125		23/108	4/8	12/15	14/18	0.09
1 1/2 in. (38.1 mm)	2	0333-0392	40/45	125/135		23/108	5/9	12/15	12/16	0.09
2 in. (50.8 mm)	3	0333-0393	40/50	150/175		23/108	5/9	14/18	10/14	0.10
2 1/2 in. (63.5 mm)	3	0333-0393	45/50	175/200		23/108	6/10	14/18	9/12	0.10
3 in. (76.2 mm)	4	0333-0394	45/50	210/250		23/108	8/12	16/20	8/11	0.12

### G-SERIES SERIES 3 TYPE GPP

Metal Thickness	Size	Part No.	Cutting Oxygen *** (psig)	Cutting Oxygen (SCFH)	Preheat Oxygen * (psig)	Preheat Oxygen (SCFH)	Acetylene (psig)	Acetylene ****(SCFH)	Speed ipm	Kerf Width
1/8 in. (3.2 mm)	000	CS3GPP000	20/25	12/14	REFERENCE PREHEAT CHART ON PAGE 158	23/108	3/5	5/6	24/28	0.04
1/4 in. (6.4 mm)	00	CS3GPP00	20/25	22/26		23/108	3/5	5/7	21/25	0.04
3/8 in. (9.5 mm)	0	CS3GPP0	25/30	45/55		23/108	3/5	8/10	20/24	0.06
1/2 in. (12.7 mm)	0	CS3GPP0	30/35	50/55		23/108	3/5	8/10	18/22	0.06
3/4 in. (19.1 mm)	1	CS3GPP1	30/35	70/80		23/108	4/6	10/12	15/20	0.08
1 in. (25.4 mm)	2	CS3GPP2	35/40	115/125		23/108	4/8	12/15	14/18	0.09
1 1/2 in. (38.1 mm)	2	CS3GPP2	40/45	125/135		23/108	5/9	12/15	12/16	0.09
2 in. (50.8 mm)	3	CS3GPP3	40/45	150/175		23/108	5/9	14/18	10/14	0.10
2 1/2 in. (63.5 mm)	3	CS3GPP3	45/50	175/200		23/108	6/10	14/18	9/12	0.10
3 in. (76.2 mm)	4	CS3GPP4	45/50	210/250		23/108	8/12	16/20	8/11	0.12

Data compiled using mild steel as test material.

\* Applicable for three hose machine torch only. With a two hose cutting torch, preheat pressure is set by the cutting oxygen.

\*\* For best results use ST 2600FC series torches and 3/8 in. hose when using tip size 6 or larger.

\*\*\* All pressures are measured at the regulator using 25 ft x 1/4 in. hose through tip size 5 and 25 ft x 3/8 in. hose for tip size 6 and larger.

\*\*\*\* Oxygen consumption is 1.1 times the acetylene under neutral flame conditions.

**WARNING:** At no time should the withdrawal rate of an individual acetylene cylinder exceed 1/7 of the cylinder contents per hour. If additional flow capacity is required use an acetylene manifold system of sufficient size to supply the necessary volume.

### G-SERIES SERIES 3 TYPE 318MP



- General purpose
- Gouging and rivet washing

Metal Thickness	Size	Part No.	Cutting Oxygen *** (psig)	Cutting Oxygen (SCFH)	Preheat Oxygen * (psig)	Preheat Oxygen (SCFH)	Acetylene (psig)	Acetylene ****(SCFH)	Speed ipm	Kerf Width
1 in. (25.4 mm)	2	CS3318MP2	35/40	115/125	REFERENCE PREHEAT CHART ON PAGE 158	44/240	3/6	22/110	14/18	0.09
1 1/2 in. (38.1 mm)	2	CS3318MP2	40/45	125/135		44/240	4/8	22/110	12/16	0.09
3 in. (76.2 mm)	4	CS3318MP4	40/50	210/250		44/240	6/9	22/110	8/11	0.12
6 in. (152 mm)	6**	CS3318MP6	45/55	400/500		44/240	6/10	22/110	5/7	0.17
8 in. (203 mm)	6**	CS3318MP6	55/65	450/500		44/240	8/12	22/110	4/6	0.18
12 in. (305 mm)	8**	CS3318MP8	60/70	750/850		50/265	10/14	25/120	3/4	0.41

## SERIES 3 – LP (PROPANE / NATURAL GAS) CUTTING TIPS

### VICTOR SERIES 3 TYPE GPN



- General purpose
- Hand and machine cutting

Metal Thickness	Size	Part No.	Cutting Oxygen *** (psig)	Cutting Oxygen (SCFH)	Preheat Oxygen * (psig)	Preheat Oxygen (SCFH)	Acetylene (psig)	Acetylene ****(SCFH)	Speed ipm	Kerf Width
1/4 in. (6.4 mm)	00	0333-0398	20/25	22/26	REFERENCE PREHEAT CHART ON PAGE 158	23/108	3/5	5/7	21/25	0.04
1/4 in. (6.4 mm)	00	0387-0182#	20/25	22/26		23/108	3/5	5/7	21/25	0.04
3/8 in. (9.5 mm)	0	0333-0399	25/30	45/55		23/108	3/5	8/10	20/24	0.06
1/2 in. (12.7 mm)	0	0333-0399	30/35	50/55		23/108	3/5	8/10	18/22	0.06
3/4 in. (19.1 mm)	1	0333-0400	30/35	70/80		23/108	4/6	10/12	15/20	0.08
3/4 in. (19.1 mm)	1	0387-0184#	30/35	70/80		23/108	4/6	10/12	15/20	0.08
1 in. (25.4 mm)	2	0333-0401	35/40	115/125		23/108	4/8	12/15	14/18	0.09
1 in. (25.4 mm)	2	0387-0185#	35/40	115/125		23/108	4/8	12/15	14/18	0.09
1 1/2 in. (38.1 mm)	2	0333-0402	40/45	125/135		23/108	5/9	12/15	12/16	0.09
1 1/2 in. (38.1 mm)	2	0387-0185#	40/45	125/135		23/108	5/9	12/15	12/16	0.09
2 in. (50.8 mm)	3	0333-0402	40/50	150/175		23/108	5/9	14/18	10/14	0.10
2 1/2 in. (63.5 mm)	3	0333-0402	45/50	175/200		23/108	6/10	14/18	9/12	0.10
3 in. (76.2 mm)	4	0333-0403	45/50	210/250		23/108	8/12	16/20	8/11	0.12
4 in. (102 mm)	5	0333-0404	45/55	300/360		23/108	8/12	20/30	7/10	0.14
5 in. (127 mm)	5	0333-0404	50/55	330/360		23/108	8/12	20/30	6/9	0.14

### G-SERIES SERIES 3 TYPE GPN

Metal Thickness	Size	Part No.	Cutting Oxygen *** (psig)	Cutting Oxygen (SCFH)	Preheat Oxygen * (psig)	Preheat Oxygen (SCFH)	Acetylene (psig)	Acetylene ****(SCFH)	Speed ipm	Kerf Width
1/8 in. (3.2 mm)	000	CS3GPN000	20/25	12/14	PREHEAT CHART ON PAGE 158	23/108	3/5	5/6	24/28	0.04
1/4 in. (6.4 mm)	00	CS3GPN00	20/25	22/26		23/108	3/5	5/7	21/25	0.04
3/8 in. (9.5 mm)	0	CS3GPN0	25/30	45/55		23/108	3/5	8/10	20/24	0.06
1/2 in. (12.7 mm)	0	CS3GPN0	30/35	50/55		23/108	3/5	8/10	18/22	0.06
3/4 in. (19.1 mm)	1	CS3GPN1	30/35	70/80		23/108	4/6	10/12	15/20	0.08
1 in. (25.4 mm)	2	CS3GPN2	35/40	115/125		23/108	4/8	12/15	14/18	0.09
1 1/2 in. (38.1 mm)	2	CS3GPN2	40/45	125/135		23/108	5/9	12/15	12/16	0.09
2 in. (50.8 mm)	3	CS3GPN3	40/50	150/175		23/108	5/9	14/18	10/14	0.10
2 1/2 in. (63.5 mm)	3	CS3GPN3	45/50	175/200		23/108	6/10	14/18	9/12	0.10
3 in. (76.2 mm)	4	CS3GPN4	45/50	210/250		23/108	8/12	16/20	8/11	0.12
4 in. (102 mm)	5	CS3GPN5	45/55	300/360		23/108	8/12	20/30	7/10	0.14
5 in. (127 mm)	5	CS3GPN5	50/55	330/360		23/108	8/12	20/30	6/9	0.14

Data compiled using mild steel as test material.

\* Applicable for three hose machine torch only. With a two hose cutting torch, preheat pressure is set by the cutting oxygen.

\*\* For best results use ST 2600FC series torches and 3/8 in. hose when using tip size 6 or larger.

\*\*\* All pressures are measured at the regulator using 25 ft x 1/4 in. hose through tip size 5 and 25 ft x 3/8 in. hose for tip size 6 and larger.

\*\*\*\* Oxygen consumption is 1.1 times the acetylene under neutral flame conditions.



# FLASHBACK ARRESTORS AND CHECK VALVES

Flashback arrestors and reverse flow check valves provide additional protection against flashbacks. Victor recommends the use of these devices whenever possible. Victor add-on flashback arrestors contain both a reverse flow check valve and a flashback arrestor.

Due to the high flow requirements of Victor Heavy Industry torches, it is important to use flashback arrestors that have sufficient flow capacity.

### Reverse Flow Check Valves:

Helps to prevent the reverse flow of gases from traveling past the check valve.

### Flashback Arrestors:

Prevents a flame from traveling past the flashback arrestor in the event of a flashback.

It is important to understand the difference between reverse flow check valves and flashback arrestors.

### The Flashback Arrestor

Prevents flashback

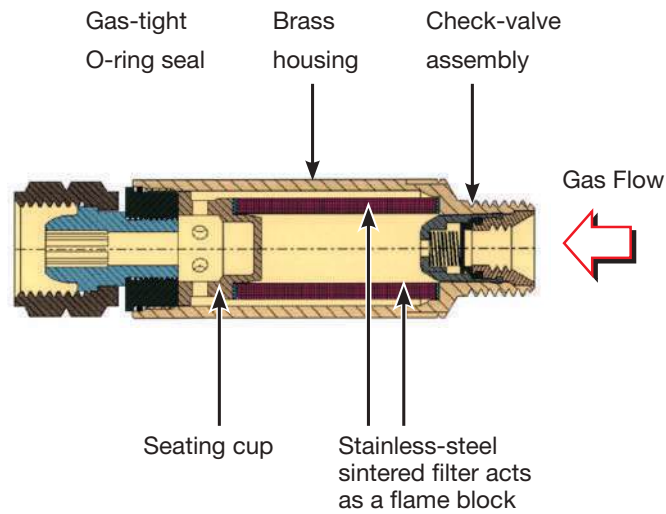

### The Check Valve

Prevents the reverse flow of gases

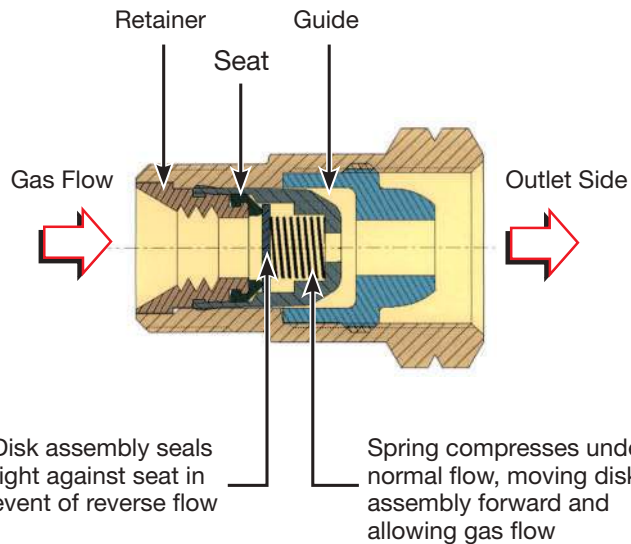

### Conversion Chart

Gas	Conversion Factor	Max. Pressure
Acetylene	1.05	15 psi
Hydrogen	3.79	30 psi
MAP-Pro	0.82	22 psi
Methane	1.34	50 psi
Oxygen	0.95	143 psi
Propane	0.80	50 psi

**NOTE:** The use of both regulator and torch mount flashback arrestors with heavy industry equipment requiring high gas volume is not recommended because it may cause excessive flow restriction. It is always better to place the safety devices at the rear of the torch than at the regulator in order to protect the hose.

# FLAMEBUSTER™ HIGH FLOW

### FBHC-O

High Flow Torch Mount



### FBHC-OR

High Flow Regulator Mount



### FBHC-OC

High Flow Torch Mount



### FBHC-ORC

High Flow Regulator Mount



# FLAMEBUSTER™

### FB-O

Torch Mount - Oxygen



### FB-OR

Regulator Mount - Oxygen



### FB-F

Torch Mount - Fuel



### FB-FR

Regulator Mount - Fuel



### FLOW Chart - FBHC Series Flashback Arrestor

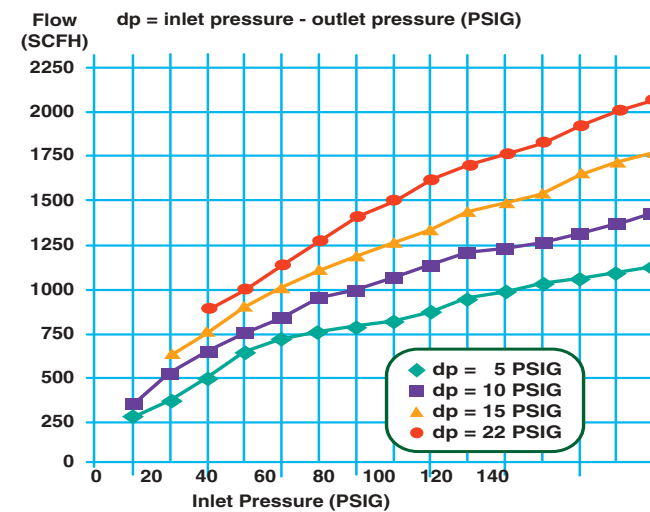

### Ordering Information

Part No.	Model No.	Gas	Description	Connection
<b>Oxygen - Torch Mount (Torch mount models also protect hose)</b>				
0657-0076	FBHC-O	Oxygen	Torch Mount - High Flow	"B" 9/16"-18 RH (CGA 022)
0657-0077	FBHC-OC	Oxygen	Torch Mount - High Flow	"C" 7/8" - 14 RH (CGA 024)
<b>Oxygen - Regulator Mount</b>				
0657-0078	FBHC-OR	Oxygen	Regulator Mount - High Flow	"B" 9/16" - 18 RH (CGA 022)
0657-0079	FBHC-ORC	Oxygen	Regulator Mount - High Flow	"C" 7/8" - 14 RH (CGA 024)

Flow rates shown in chart are for air. To convert to other gases, multiply the air flow rate by the conversion factor listed.

Nothing can take the place of proper equipment operation. Always read, understand and follow the instructions provided with each product.

### FLOW Chart - FB Series Flashback Arrestor

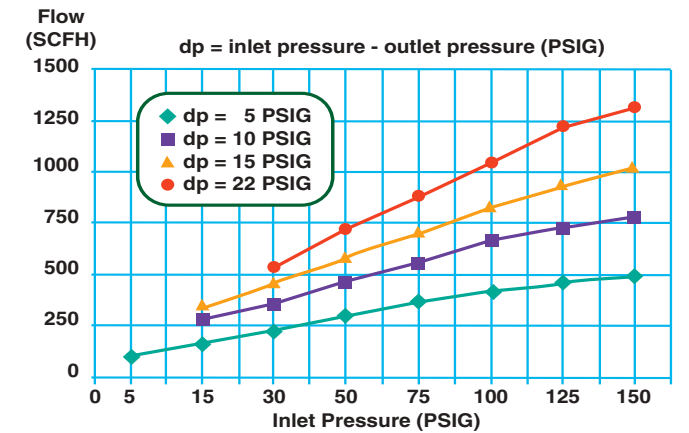

### Ordering Information

Part No.	Model No.	Gas	Description	Connection
<b>Oxygen - Torch Mount</b>				
0657-0010	FB-O	Oxygen	Torch Mount	"B" 9/16"-18 RH (CGA 022)
<b>Oxygen - Regulator Mount</b>				
0657-0014	FB-OR	Oxygen	Regulator Mount	"B" 9/16"-18 RH (CGA 022)
<b>Fuel - Torch Mount</b>				
0657-0011	FB-F	Fuel	Torch Mount	"B" 9/16"-18 LH (CGA 023)
<b>Fuel - Regulator Mount</b>				
0657-0015	FB-FR	Fuel	Regulator Mount	"B" 9/16"-18 LH (CGA 023)
<b>Pair Packs</b>				
0656-0001	FB-1	Oxy/Fuel	Torch Mount	"B" 9/16"-18 RH/LH (CGA 022 & 023)
0656-0004	FBR-1	Oxy/Fuel	Regulator	"B" 9/16"-18 RH/LH (CGA 022 & 023)

Flow rates shown in chart are for air. To convert to other gases, multiply the air flow rate by the conversion factor listed.

Nothing can take the place of proper equipment operation. Always read, understand and follow the instructions provided with each product.

Victor® add-on flashback arrestors contain both a reverse flow check valve and a flashback arrestor.



# FLAMEBUSTER™ PLUS

- Flashback Arrestor with Kwik-Connect™ Coupling
- Designed to prevent flashback from torch to hose (Not for regulators)



Ordering Information	
0656-0002	FBP-1 FlameBuster Plus Torch - Pair Pack
0657-0002	FBP-0 FlameBuster Plus Torch
0657-0003	FBP-F FlameBuster Plus Torch

Plug Assemblies available: Oxygen: 0657-0031, Fuel: 0657-0032

# FLASHBACK ARRESTORS

Pair Packs



Ordering Information				
Part No.	Model No.	Gas	Description	Connection
0656-0006	FBT-2	Oxy/Fuel	Torch Mount	"B" 9/16"-18 RH/LH (CGA 022 & 023)
0656-0007	FBR-2	Oxy/Fuel	Regulator Mount	"B" 9/16"-18 RH/LH (CGA 022 & 023)

# REVERSE FLOW CHECK VALVES

for Torches & Regulators



Ordering Information	
<b>Torch Models</b>	
0690-0011	CTO & CTF Torch - Check Valves Pair Pack (Oxygen & Fuel)
0690-0032	CTO Torch - Check Valve (Oxygen)
0690-0033	CTF Torch - Check Valve (Fuel)
<b>Regulator Models</b>	
0690-0012	CRO & CRF Regulator - Check Valves Pair Pack (Oxygen & Fuel)
0690-0034	CRO Regulator - Check Valve (Oxygen)
0690-0035	CRF Regulator - Check Valve (Fuel)

# BUILT-IN FLASH ARRESTOR

Retro-Fit Kit

The retro-fit kit allows replacement of built-in flash arrestors for cutting torches without the use of Loctite® or heat

## Ordering Information

### Torch/Hose Connections

0656-0046 Includes oxygen and fuel cartridges, retainer plate and screws, hex key, and instructions

Repair of oxy/fuel equipment, including flashback arrestor and check valve replacement, should be done by a qualified technician.

# FLASHBACK ARRESTOR

with Kwik-Connect Coupling  
Components FBP-1

## Ordering Information

0657-0031	Male End Oxygen
0657-0032	Male End Fuel Gas

# VANGUARD™ FLASHBACK ARRESTORS

Replacement Cartridge



## Ordering Information

### Torch/Hose Connections

0657-0036	Torch and Torch Handle Replacement Cartridge (315FC, 100FC, J 100FC) (CST 800FC) (Both Gases)
0657-0068	Torch & Torch Handle Replacement Cartridge (H 315FC, ST 900FC, ST 1000FC, ST 2600FC) (Oxygen)
0657-0069	Torch & Torch Handle Replacement Cartridge (H 315FC, ST 900FC, ST 1000FC, ST 2600) (Fuel Gas)

Flashback arrestor replacement cartridges include an "O" ring but does not include a replacement reverse flow check valve. Part No. 0690-0027 - 9/16" (pair).

# KWIK-CONNECT

Torch/Hose Connections



## Ordering Information

### Torch/Hose Connections

0656-0000	KC-1 Kwik Connect Pair Pack (Oxygen and Fuel)
0312-0090	KCO Kwik Connect (Oxygen)
0312-0091	KCF Kwik Connect (Fuel)

# VCM 200/201

Portable Cutting Machines

The versatile VCM 200 is a precision, tractor-type machine that can be used on its own track for straight line cutting and a variety of welding operations. Off track and with a radius rod assembly, the VCM 200 can also be used for circle cutting.

- Large thumb screws for hand tight adjustments
- Dual drive controls & direct speed readout
- Cone disc drive
- Constant speed AC induction motor located on the side opposite the torch for cooler, more efficient operation
- Counter-balanced design allows torch racking distance up to 18 in. (457.2 mm) from the machine
- Speed constant over wide range of temperatures
- Torch holder designed for 1.38 in. (35.1 mm) barrel diameter torches
- Flat mounting deck
- HT (HIGH TEMPERATURE)** Same convenience, portability features and speed of the VCM-200 (Max. temp. 300°F), plus the addition of a heat shield.
- HS (HIGH SPEED)** Has all the convenience and portability features of the standard VCM-200 machine, plus a speed range of 5-120"/min (12.7-304.8 cm/min). The VCM-200HS has a flat mounting deck.

## Specifications

### Straight Line / Circle

- Length increments of 72 in. (182.9 cm) (track length)
- Circle diameters 4 in. (101.6 mm) to 96 in. (243.8 cm)

### Speed Range

- 1-60 in./minute (25.4 mm-152.4 cm/minute)

### Dimensions

- Length - 14.25 in. (362.0 mm)
- Width - 11 in. (279.4 mm) - machine only  
- 28.5 in. (723.9 mm) - machine & torch holder
- Height - 11.5 in. (292.1 mm) - top of torch holder  
- 5.5 in. (139.7 mm) - top of machine

### Weight

- Machine - 47 lbs (21 kg)

Ordering Information			
Part No.	Model No.	Speed Range/Minute	See Package Description
0200-0220	VCM 200 Portable Cutting Machine Package	1 in.-60 in. (25.4 mm-152.4 cm)	See Package Description #1
0200-0222	VCM 200E**	1 in.-60 in. (25.4 mm-152.4 cm)	See Package Description #1
0200-0224	VCM 200 HS Portable Cutting Machine Package - High Speed	5 in.-120 in. (127 mm-304.8 cm)	See Package Description #1
0200-0226	VCM 200HSE**	5 in.-120 in. (127 mm-304.8 cm)	See Package Description #1
0200-0240	VCM 200 HT Portable Cutting Machine Package - High Temperature	1 in.-60 in. (25.4 mm-152.4 cm)	See Package Description #1
0200-0221	VCM 201 Portable Cutting Machine Package	1 in.-60 in. (25.4 mm-152.4 cm)	See Package Description #2
0200-0225	VCM 201 HS Portable Cutting Machine Package - High Speed	5 in.-120 in. (127 mm-304.8 cm)	See Package Description #2
0200-0241	VCM 201 HT Portable Cutting Machine Package - High Temperature	1 in.-60 in. (25.4 mm-152.4 cm)	See Package Description #2

\*Models VCM-200 HT, VCM-201 HT, include heat shield

\*\*Export models available with 220V AC to 110V AC step down transformer



PORTABLE CUTTING MACHINE

## TORCH HOLDER ADAPTER

### Part No. 0252-0138

The Torch Holder Adapter is used to adapt the Victor® Thermal Dynamics® SL100 180° Degree plasma torches to the VCM machine. The torch adaptor allows the machine torch to mount on 1 3/8" mounting tube.

Please contact Technical Services on 1-800-426-1888 for more information.

Accessory Ordering Information	
12 ft (3.7 m) Track Section for Line Cutting	0212-0018
9 ft (2.7 m) Track Section for Line Cutting	0212-0019
6 ft (1.8 m) Track Section for Line Cutting	0212-0005
Radius Rod for Circle Cutting	0252-0040
100 in. (254.0 cm) Radius Rod for Circle Cutting	0253-0042
Dual Torch Mount Assembly	0252-0136
Heat Shield	0252-0103

## PACKAGE DESCRIPTION #1 VCM 200: PACKAGE DESCRIPTION #2 VCM 201:

- Cutting machine
- MT 210A torch & torch rack
- Hoses & fittings (for 2 hose operation)
- Hoses & fittings (for 2 hose operation)
- 32 pitch pinion torch holder
- 3 hose manifold block
- Cutting machine
- Hoses & fittings (for 2 hose operation)
- 32 pitch pinion torch



# MODEL BHA 2



Model BHA 2 adjustable head adds flexibility to machine cutting torches by allowing bevel cuts without changing the position of the torch. It can be set at any angle from 0 to 90° on either side of vertical.

- Uses Series 1 cutting tips
- Optional preheat attachment is available for use with the BHA adjustable head attachment. The preheat attachment uses replaceable tip ends

Ordering Information	
0383-0012	BHA 2
0304-0060	Preheating Attachment

Tip nut included (not shown)

# CIRCLE CUTTING ATTACHMENT



Circle Cutting Attachment is easily attached to a cutting torch or cutting attachment. The roller guide is adjustable to various heights and is designed to hold the cutting tip at exact pre-set distance from the work. Cutting range 1.5" (38.1 mm) - 28" (71.1 cm) circle.

Ordering Information	
0383-0006	D 496 Circle Cutting for Series 1 tips

# MODEL 591

Model 591 strip cutter for use with machine cutting torches only. It is designed to accept two tips for use with a common torch.



- Uses Series 1 cutting tips
- Adjustable for cutting strips from 1.25" (31.8 mm) to 12" (304.8 mm) wide, and thickness up to 3" (76.2 mm)

Ordering Information	
0383-0000	591 Strip Cutter

# TEST GAUGES

For use when accurate line pressure is needed.



Ordering Information	
1420-0004	Oxygen, Model PD-10 100# Test, 2" (50.8 mm) Dia. Gauge
1420-0003	Fuel Gas, Model PD-11 30# Test, 2" (50.8 mm) Dia. Gauge

# MODEL 497 ROLLER GUIDE



Model 497 roller guide is adaptable to most styles of cutting tips. Fits over the cutting tip shank and is fully adjustable for close, accurate work.

Ordering Information	
0383-0009	497 Roller Guide

# GEAR RACKS



For use with MT 200 and MT 300 Series cutting torches. (Must be ordered separately)

Ordering Information				
Part No.	Length	Pitch	Cutting Machine	Actual Length
0319-0054	10" (254.0 mm) Rack Kit	32	MT 210 & MT 310	7.8" (198.1 mm)
0319-0055	18" (457.2 mm) Rack Kit	32	MT 318	14.5" (368.3 mm)

# REPLACEMENT HOSES



Part No.	Description	Fitting	Fuel Gas Type
1412-0214	1/4 in. x 20 ft. Dual T-Grade	"B" 9/16"-18	All
1412-0213	3/16 in. x 20 ft. Dual T-Grade	"B" 9/16"-18	All
1412-0212	3/16 in. x 12.5 ft. Dual T-Grade	"B" 9/16"-18	All
1412-0211	3/16 in. x 12.5 ft. Dual T-Grade	"A" 3/8"-24	All

# TRIPLE FLINT STRIKER



Ordering Information	
0386-0297	Triple Flint Striker

# TK TANK KEY



- Fits B & MC Tanks

Ordering Information	
0386-1226	TK Tank Key

# FLINT REFILLS



- F-1 Flint Refills
- For L- Single Flint Striker



- For Triple Flint Striker

Ordering Information	
1423-0024	F-1 Flint Refills for L-Single Flint Striker
0386-0298	Flint Refills for Triple Flint Striker

# L1- SINGLE FLINT STRIKER



Ordering Information	
1423-0061	L1 Single Flint Striker

# TIP CLEANER



Ordering Information	
0386-1213	Tip Cleaner

## Withdrawing Acetylene from Cylinders

(1/7th rule as per the CGA.G -1.2009 section 6.2)

Never use acetylene through torches or other devices equipped with shut-off valves on the acetylene supply connections without reducing the pressure through a suitable acetylene regulator attached to the cylinder valve. Acetylene should not be used at a pressure exceeding 15 psig (103 kPa).

Observe the following precautions when connecting and using acetylene cylinders:

- It is always preferable to use acetylene cylinders in a secured upright position. Use in a horizontal position does not make the acetylene less stable, but it does prevent ease of access to the valve and regulator assembly;
- Never use wrenches or other tools for opening or closing cylinder valves except those provided by the valve or acetylene manufacturer;
- Visually examine the CGA connection on the cylinder and remove any visible contamination before connecting the regulator. Clean out the contaminant using nitrogen, air, or a clean rag. Avoid opening an acetylene cylinder valve without a suitable regulator and flow restrictor such as a torch attached;
- Regulators and pressure gauges provided for use with a particular gas or gases shall not be used on cylinders containing any other gas. To prevent interchanging of equipment, be sure that the threads on regulators or other unions correspond to those on cylinder valve outlets;
- After attaching the regulator and before the cylinder valve is opened, check that the pressure adjusting screw of the regulator is released or backed out;
- Be sure that all connections are gas-tight and that the connected hose is in good condition and does not have any leaks;
- Always open the acetylene cylinder valve slowly. Never use a hammer or mallet in attempting to open or close a valve;
- An acetylene cylinder valve should be opened the minimum amount required to deliver acceptable flow so it can be closed as quickly as possible in an emergency situation. One and one-half turns is usually sufficient to provide adequate flow;
- Do not pile hose, tools, or other objects on top of an acetylene cylinder since this might interfere with quick closing of the valve;
- The wrench used for opening the cylinder valve should always be kept on the valve spindle when the cylinder is in use;
- Always close the cylinder valve when the work is finished. Be sure the cylinder valve is closed and all gas released from the regulator before removing the regulator from a cylinder;
- Never apply a torch to the side of a cylinder to raise the pressure (serious accidents have occurred due to violation of this precaution);
- Experience has shown that for welding, cutting, and allied processes, a withdrawal rate of 1/7 of the cylinder capacity per hour is generally acceptable;
- To minimize the withdrawal of liquid solvent in applications that are more sensitive to solvent carry-over, acetylene should be withdrawn from the cylinder at a rate not to exceed 1/10 of the capacity of the cylinder per hour during intermittent use, and for withdrawal of the contents of the cylinder on a continuous basis, the flow rate should be no more than 1/15 of the capacity of the cylinder per hour; and
- Never open a valve without proper attachments (regulator and torch or regulator and flow restriction of some type such as a flowmeter). Opening the cylinder valve without proper attachments can cause a cylinder to spit acetone and can cause an acetylene fire.

### Gas Equipment Product Compliance Standards:

- Regulators meet UL 252, CGA E-4, and are ETL Listed to UL 252
- Cylinder/Hose Connections meet CGA V-1, CGA E-1
- Torches (both Cutting Attachment and Handle) meet UL 123, and are ETL Listed to this standard
- Hose meets ARPM IP-7
- Goggles meet ANSI Z87.1 and CSA Z94.3-M88 (US and Canada face & eye protection standards)

**ESTD TRUE 1913**  
**VICTOR**  
AN ESAB BRAND

**ONLY ONE BRAND  
CAN LEAD YOU TO VICTORY.**

For more than 100 years, we've been the brand the industry looks to for safe, reliable, and long-lasting equipment. And that's a title we're just not willing to give up. Ever. We don't copy innovative technology, we invent it. We don't sacrifice to sell, we overdeliver. Time and again. Choose the brand that has the control and consistency you need to become a true ruler of the flame.