

DALY New Hardware BMS User Manual

1、Product catalog

DALY | New Hardware Selection

Catalog					
Model	G	H	K	M	
Type	J13G3	J16H3	J24K3	J24M3	J24M3
Strings	3~13S	3~16S	3~24S	3~24S	3~24S
Current(standard product)	15A/20A	40A/60A	40A/60A/ 100A	150A	200A

Note: This operation manual is applicable to the above hardware BMS.

2、Wiring diagram

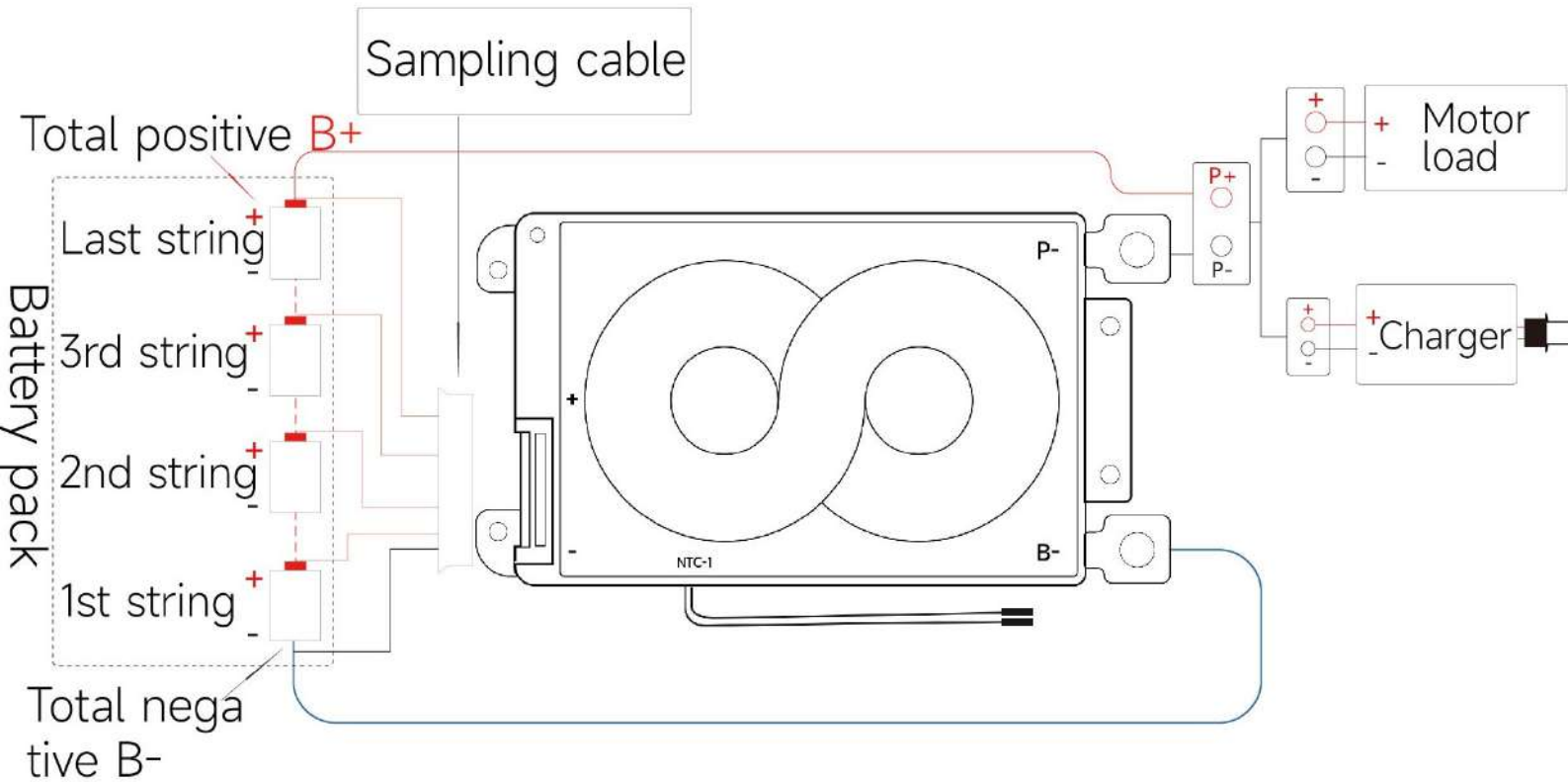

Note: This wiring diagram takes K series 100A BMS as an example.

Wiring sequence of battery:

Attention:

- Wires of different BMS suppliers are different, please make sure to use the matching wire; different BMS suppliers' B- and P- cables have different colors, please pay attention to B- and P- logo;
- When welding sampling wires, be sure not to plug the wires to the BMS;

1.The sampling wires starts from the thin black wire to the total negative electrode B-, the second wire (red wire) connects the positive electrode of the first string of battery, followed by the positive of each string of battery, until finish connecting the last string of total positive electrode B+;

2.After the sampling wires are connected, do not directly plug them to the BMS. First check that the sequence is correctly connected. If the voltage of NMC(-Li-ion) battery should be between 3.0~4.15V; the voltage of LFP(LiFePO4) battery should be between 2.5~3.6V; the voltage of LTO(Lithium-titanate battery) should be between 1.8~2.8V. Please make sure that the voltage is correct before the next operation;

3.Plug the NTC(ensure that the temperature sensor is inserted at the NTC port);

4.Connect B- on the BMS to the total negative electrode of the battery(the length of the B- wire should not exceed 40cm);

5.Insert the sampling wire into the BMS;

6.Measure whether the battery voltage between B+ & B- and voltage between B+ & P- are the same (The voltage of the battery pack is the same as the voltage after the BMS). If voltage are the same that means the BMS works normally. If not, please check wiring sequence according to the above.

3、Points for attention

- 1.Recommended screw torque of 8~10N·m(nm).
- 2.When the BMS is used in a solar charging system, you need to wait for the BMS to detect the battery voltage before charging. A small charging board must be selected for use in order to make the whole system work properly.
- 3.After confirming that the wire is welded correctly, insert the wire into the BMS (Note: the blue B- wire on the BMS is connected to the total negative electrode of the battery, and the black P- wire is connected to the negative electrode of the charge and discharge), and then install the accessories with the product (such as: standard temperature control/optional power board/optional Bluetooth/optional GPS/optional display screen/optinal customized communication interface) on the BMS.
- 4.When the NTC is not inserted, the BMS cannot perform normal and will cut off charge and discharge.
- 5.If the BMS is damaged, we will only provide paid repairs. Property losses caused by battery failure will be borne by the user. Our company only provides maintenance and after-sales service for the BMS.