

Portable Solar Power Generator

EB150 User Manual

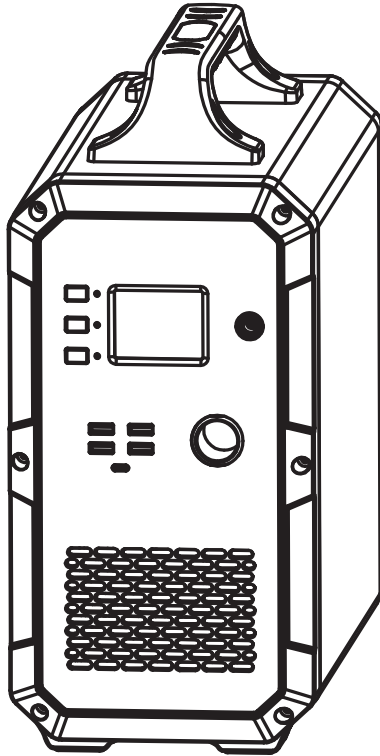

NOTICE:

Please strictly follow all the operating instructions in this manual and warnings on the Portable Solar Power Generator (hereinafter referred to as generator) and keep the manual in a safe place. Please do not operate until you have read all the safety instructions and operating instructions.

Contents

1. Brief introduction	1
1.1. Preface.....	1
1.2. Product description.....	1
1.3. Appearance introduction.....	1
1.4. Safety precaution.....	2
1.5. Operation and maintenance.....	2
1.6. Block diagram.....	3
2. Unpacking	3
2.1. Unpack checking.....	3
3. Operation instruction	4
3.1. Power on and power off.....	4
3.2. PV charge activation.....	5
3.3. Screen display.....	5
3.4. Intelligent cooling.....	6
3.5. Inverter output frequency setting.....	6
4. Trouble shooting and technical specification	6
4.1. Trouble shooting.....	6
4.2. Detail technical specification.....	8
5. Contact us	9

1. Brief introduction

1.1. Preface

This manual will provide detail product information and instructions for users' operation. Please read this manual carefully before using the generator, and keep this manual in safe place for easy operation and maintenance in the after.

After careful reading of this manual, users can operate this generator properly, and get quick trouble-shooting info.

1.2. Product description

The generator is a small family portable energy storage system. The generator integrates solar charge controller, system controller, inverter, lithium battery, DC 12V, 5V-USB, TYPE C-PD and battery management system. The clean and environmentally friendly solar energy is stored in the battery. It is used for a short time, such as lighting, computer, small power household appliances, in the case of power outage or outdoor. The generator has the advantages of stable performance, safety and reliability, and convenient operation.

1.3. Appearance introduction

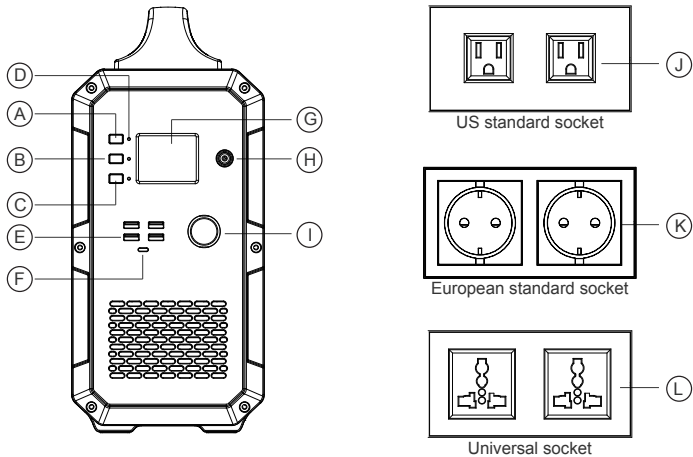

- Ⓐ Master power button Ⓑ DC output button Ⓒ AC output button Ⓓ LED indicator light
- Ⓔ 5V USB output Ⓕ Type C-PD output Ⓖ Display screen Ⓗ Charger/ PV charge input port
- Ⓘ 12V cigarette lighter output ⓵ AC 110/120V output US standard socket
- Ⓚ AC 230V output European standard socket Ⓛ AC 230V output Universal socket

1.4. Safety precaution

1. Before using this generator, please read the "safety instructions" carefully to ensure correct and safe use, and keep the manual in a safe place. If the generator is damaged due to failure to follow the instructions in this manual, the company reserves the right not to carry out quality assurance.
2. During operation, please pay attention to all warning signs and operate as required.
3. Avoid direct exposure to the sun, rain or wet environment to use this equipment.
4. The generator can not be installed near the heat source area, or near the similar appliances such as electric heaters and hot stoves.
5. When placing products, there must have safe space around them to ensure ventilation. When installing, refer to the instructions.
6. When cleaning, please use dry articles to wipe.
7. In case of fire, please use the dry powder fire extinguisher correctly. If you use a liquid fire extinguisher, there will be an electrical shock.
8. When using, please do not move the other parts of the chassis except the wiring terminals.
9. If the generator needs maintenance, please contact the local designated system installation and maintenance personnel.

1.5. Operation and maintenance

1. The use environment and preservation methods have certain effects on the service life and reliability of the generator. Therefore, be careful not to use it in the following work environments:
 - Excess technical indicators (temperature 0°C to 40°C , relative humidity 10% ~ 90%) of the high and low temperature and damp places.
 - Place have vibration and easy for collision.
 - Place where have gold dust, corrosive substances, salts and combustible gases.
2. The area where the generator is placed should be well ventilated and away from dangerous goods such as water, inflammable gas and corrosive agents.
3. If the generator is unassembled used in low temperature, it may lead to water drops congealed, in this case must wait until the generator inside/outside is all dry, then it can be installed and used, otherwise there will be risk of electric shock.
4. If do not use the generator for a long time, it must be stored in a dry environment, best storage temperature is 0°C ~ 35°C .
5. Generator will turn off automatically when the battery voltage is too low. Make sure to charge the generator within 15 days when this happens.
6. Make sure the battery level is lower than 30% before packaging for shipping.
7. Generator must be fully charged and recharged every 3 months and be kept in a dry and cool place if it will not be used for a long time.

1.6. Block diagram

The generator collects AC power and PV power and stores in built-in battery through charge controller, and supply AC power from battery to small appliances through AC pure-sine-wave inverter, and 12V 9A power for car devices through car cigarette lighter, and 5V power for mobile phones, tablets etc. through USB/Type C output port.

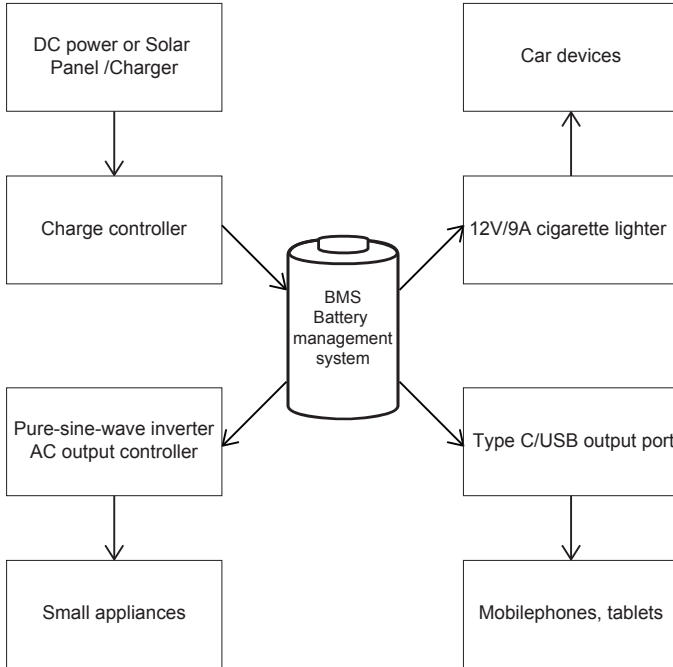

2. Unpacking

2.1. Checking

Before opening the package, please check if the packaging is damaged. After unpacking, please check if product appearance is damaged or any part is missing. If so, please contact us.

Accessories are as follows:

No.	Item	Quantity
A	Portable solar power generator	1
B	AC wall charger (Including AC input charging cable)	1
C	PV solar charge cable (7909 to MC4)	1
D	User manual	1
E	Warranty card	1
F	Certificate of qualification	1

3. Operation instruction

3.1. Power on and Power off

(1) Main function of POWER button

① Turn on: Press the master power button more than 1 second can turn on the generator, then the power LED indicator and LCD screen will be lit up.

② Turn off: Press the main power button more than 1 second can turn off the generator, LCD screen will turn off ,after loosen hand the power LED indicator will go out.

(2) Main function of DC button

① Turn on DC function: long press DC ON button more than 1 second can open DC function, DC LED will be lit up and screen will show" DC ON".

② Turn off DC function: long press DC ON button more than 1 second can close DC function, DC LED will go out and screen will show" DC OFF".

(3) Main function of AC button

① Turn on AC function: long press AC ON button more than 1 second can open AC function, AC LED will be lit up and screen will show" AC ON".

② Turn off AC function: long press AC ON button more than 1 second can close AC function, AC LED will go out and screen will show" AC OFF".

3.2. PV charge activation

(1) Turn off generator, connect PV(or charger)to charge, activate PV charge function, the first column on screen will be lit up and show input power, at this time, the generator is in charging state, can not support AC and DC functions. If want to open AC and DC functions, need to press master power button more than 1 second to turn on the generator, screen will be all lit up after generator be turned on.

(2) After start-up, connect PV(or charger) to start charging,screen shows input power wattage, at this time, can open AC and DC functions.

Notice:

If Master Power Button is not turned on, AC button and DC button are in off status, no AC output and DC output.

If Master Power Button is turned on, AC button and DC button are still in off status, no AC output and DC output. Need to turn on AC power button and DC power button separately.

3.3. Screen display

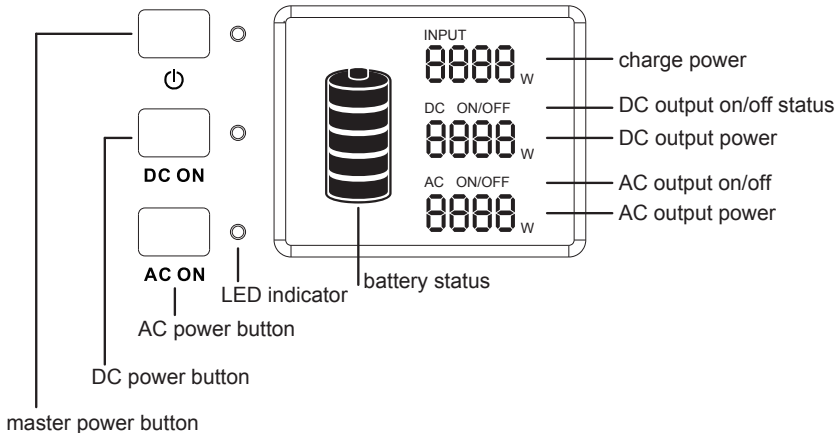

Notice:

(1) The failure code will appear at the point of 'charge power', 'DC output power' and 'AC output power'.

(2) Generator will turn off automatically after 60s, if the master power button is turned on, while DC or AC power button is not turned on or no other operations.

(3) The backlight will go out , if the master power button, DC or AC power button are turned on and no operation after a while. Press any button will light up the backlight again.

3.4. Intelligent cooling

Generator intelligent system will turn on fans for cooling when meets any conditions below:

1. Inverter load > 400W;
2. 5V USB load > 10W;
3. TypeC-PD load > 30W;
4. 12V cigarette lighter load > 50W;
5. PV input power > 100W.

Besides, generator intelligent system will adjust the PV input or AC output power based on the outer case temperature, to keep the outer case at a touchable temperature.

Notice:

Don't use generator when any fan is bad.

3.5. Inverter output frequency setting

Turn on the master power button and DC power button. Keep AC power button in off status.

Press DC power button and AC power button and hold for 1s to enter setting mode.

Press AC power button to choose inverter AC output frequency.

Press DC power button and AC power button and hold for 1s to exit setting mode.

4. Trouble shooting and technical specification

4.1. Trouble shooting

Fault code	Cause	Action
E001	All battery over-voltage protection	No charge, only discharge.
E002	All battery low-voltage protection	Fully charged and re-power on
E003	All battery failure	Re-power on generator and charge
E004	All battery discharge over-temperature protection	Temperature is too high. Repower on after cool down.
E005	All battery discharge low-temperature protection	Environment temperature is too low. Repower on when environment temperature is higher.
E006	All battery charge over-temperature protection	Battery pack is over-temperature. Charge when the temperature is lower.

E007	All battery charge low-temperature protection	Battery pack is low-temperature. Charge when the temperature is higher.
E008	1st group battery low-voltage protection	Charge and repower on
E009	2nd group battery low-voltage protection	Charge and repower on
E010	3rd group battery low-voltage protection	Charge and repower on
E011	4th group battery low-voltage protection	Charge and repower on
E012	Inverter bus cable voltage failure	Turn off and repower on
E013	Inverter over-load protection	Reduce the load. Repower on AC
E014	Inverter short-circuit	Correct the short-circuit output. Repower on AC
E015	Inverter cooling fin discharge over-temperature protection	Repower on when the cooling fin temperature is lower.
E016	Inverter cooling fin temperature detector is fall off	Connect NTC and repower on
E017	PV input over-voltage protection	To check if you use proper PV input voltage solar panel array. If yes. Then disconnect PV and repower on and connect PV.
E018	PV output over-voltage protection	To check if you use proper PV input voltage solar panel array. If yes. Then disconnect PV and repower on and connect PV.
E019	PV cooling fin charge over-temperature protection over-temperature protection	Recharge after the cooling fin temperature is lower.
E020	PV cooling fin temperature detector is fall off	Repower on.
E021	Battery protection board charge protection	Recharge after the protection board temperature is back to normal.
E022	Battery false protection	Disconnection PV, repower on.
E023	Generator over-load (AC&DC) protection	Reduce the total load and repower on.

Notice: Please contact your sales if you don't know how to do.

4.2. Detail technical specification

Model		EB150-P1	EB150-P2
Output Sepc.			
Inverter AC output	rated output	1000W	1000W
	peak output	2000W	2000W
	rated voltage	110Vac	230Vac
	rated frequency	50/60Hz	50/60Hz
	Power factor	1	1
	THDV@R load	<5%	<5%
	overload	1000W<load<1200W@2min 1200W<load@1s	
	"self consumption no load consumption"	<20W	<20W
	max efficiency(>70% load)	88%	90%
DC 12V cigarette lighter output	rated output voltage range	12.2V(±1V)	12.2V(±1V)
	rated output current	9A	9A
5V USB output	output voltage range	5V±0.3V	5V±0.3V
	max output current	3A	3A
	remarks: 2pcs USB(top and down) is one group	max output is 3A for one USB max output is 3A for one group -- 2pcs USB(top and down)	
TypeC-PD output	quick charge supported	PD protocol	PD protocol
	output voltage range	5~20V (default is 5V)	5~20V (default is 5V)
	rated output current (under constant voltage test)	(5V/9V/12V/15V)3A, 20V/2.25A	(5V/9V/12V/15V)3A, 20V/2.25A
Input			
AC adapter charger		42V/160W	42V/160W
PV max input power		500W	500W
PV input voltage range		16-60Vdc	16-60Vdc
PV max input current		10A	10A
PV charge type		99.5%	99.5%
MPPT efficiency		>88%	>88%
max efficiency		MPPT	MPPT
Battery			

rated voltage	14.8Vdc	14.8Vdc
rated capacity	1500Wh	1500Wh
built-in battery cell	LG	LG
battery packing	4S3P	4S3P
General		
IP	IP 21	
using environment	relative humidity:10%-90%	
	temperature:0-40℃	
product size	371.5*165.4*364.7mm	
bare weight	17.2 KG	
NOTICE:Generator system turns off DC output first when the total output power is larger than 1000W. No AC output power data shows on screen when the inverter load is less than 30W, and the tolerance is in 30W.		

5. Contact US

When there is faulty , You are required to provide the following listed information:

(1) Regarding the Unit

- Serial No.
- Model.
- The information of LCD display.
- Describe the problem briefly.
- Can you repeat this failure? If yes, what is the situation?
- Has this problem appeared in the past?
- What is the cause of the problem?

(2) Regarding the solar panels

- Manufacturer name and model of solar panels.
- Output power of solar panel.
- Output voltage of solar panel.
- MPPT output voltage of solar panel.
- MPPT output current of solar panel.
- Number of solar panels.

