



# LITHIUM BATTERY PACK

## ESS-48V 100Ah

### FEATURES

Lithium Iron Phosphate (LiFePO4): the Safest Lithium Technology.  
 Integrated Battery Management System(BMS).  
 Bluetooth/RS485/RS232/SMBus/CANBus (Optional).  
 SOC LED/LCD Indicator(Optional).

### PERFORMANCE

Long Cycle Life > 2000cycles @80% DOD.  
 High Density, High Discharge Current, High Temperature Range.  
 Low Weight, Free Maintenance.  
 Fast Charging.  
 Environment Friendly.

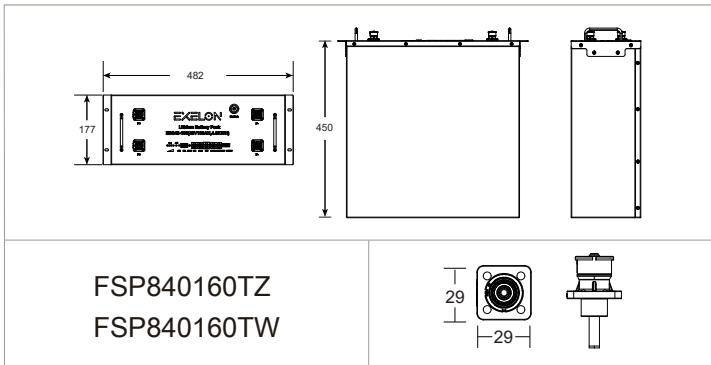

### CHARACTERISTICS

Item	Specifications
Nominal Voltage	48V
Rated Capacity	100Ah
Energy	4800Wh
Resistance	≤30mΩ
Efficiency	99%
Cycle Life	>2000cycles @ 80% DOD
Self Discharge	2% per Month

Dimension(L x W x H)	482 x 450 x 177 mm
	18.98 x 17.71 x 6.97"
Weight	43.5kg(95.9lbs)
Terminal Type	FSP840160TZ/TW
Battery Housing	Metal
Housing Protection	IP56
Cell Type-Chemistry	LiFePO4 Battery Cell
SoC Display	LED/LCD Indicator

Charge Method	CC-CV
Charge Voltage	54~55.5V
Recommended Float Voltage	51.75V
Recommended Charge Current	50A
Maximum Charge Current	100A
BMS Charge Cut-off Voltage	58.5V

Discharge Temperature	-20 to 60°C (-4 to 140°F)
Charge Temperature	0 to 45°C (32 to 113°F)
Storage Temperature	0 to 60°C(32 to 140°F)
BMS High Temperature Cut-off	80°C(176°F)

Continuous Discharge Current	100A
Pulse Discharge Current	300A(<3seconds)
Recommended Volt. Disconnect	37.5V
BMS Discharge Cut-off Voltage	30V
Reconnect Voltage	34.5V
Short Circuit Protection	200~600 us

## CHARACTERISTICS

- + Military Power Supply
- + Solar Energy Storage System
- + Solar Street LED Lightings
- + Industrial Robotics & Handling Equipment
- + Aerial Work Platform

DISCHARGE CAPACITY at VARIOUS TEMPERATURES  
DISCHARGE @0.5C, 25°C

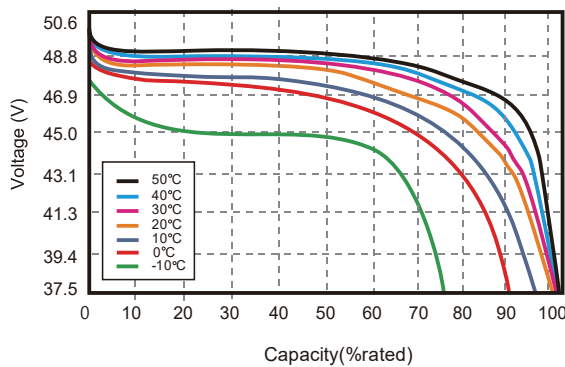

CHARGING CHARACTERISTICS @0.5C, 25°C

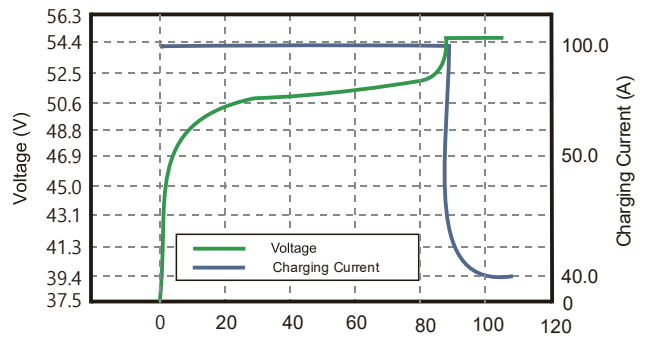

CYCLE LIFE vs. DEPTH OF DISCHARGE(DOD)  
DISCHARGE@0.5C, 25°C

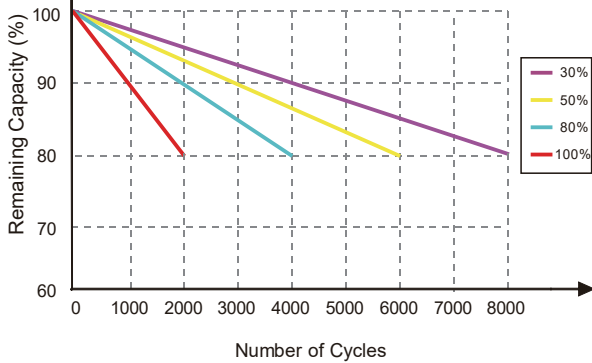

STATE OF CHARGE CURVE @0.5C, 25°C

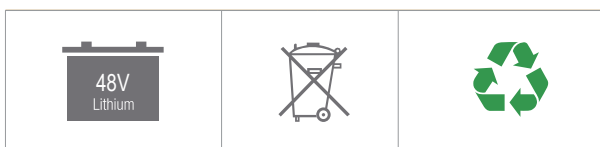
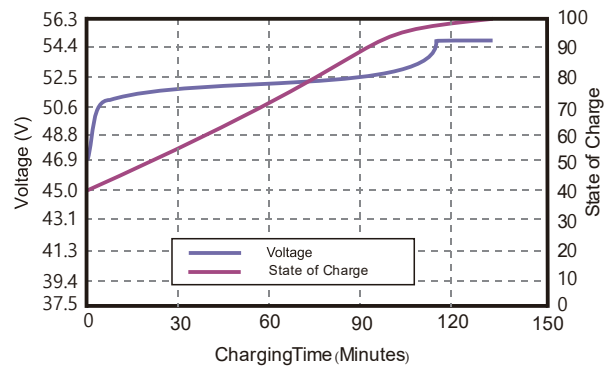

[www.exelone.com](http://www.exelone.com)

**NOTE:** Do Not Mix With Sealed Lead Acid Batteries When Recycling.

