

5-Şamandra
(Level sensor)

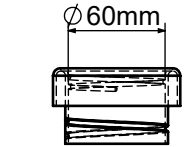

4-Dolum Boğazı
(Filling Neck-Ø60mm)

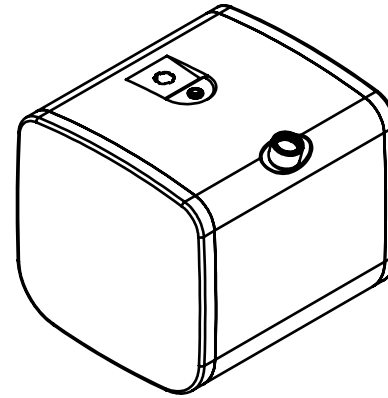
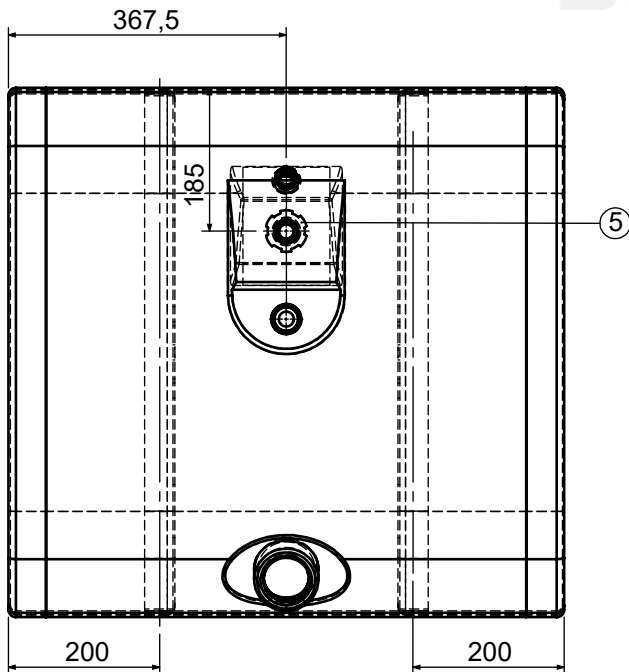

No / Item	Adet / Qty	Parça Adı / Part Name	Malzeme / Material
1	1	Gövde / Body	Aluminum 5754 H22 - 2,5mm
2	2	Yan Kapak / Side Plate	Aluminum 5754 H111 - 2,5mm
3	2	Dalgakıran / Baffle Plate	Aluminum 5754 H111 - 2,5mm
4	1	Dolum Boğazı / Filling Neck	Aluminum 5754 H111 - 2,5mm
5	1	Şamandra / Level Sensor	
6	1	Havalandırma valfi / Vent valve/Nut1/2" BSP	Aluminum 6082
7	2	Emiş,Tahliye / Suctron Adater/Nut M22X1,5	Aluminum 6082
8	2	Rondela / Washer 22mm	Aluminum 6082
9	2	Emiş,Tahliye / Suctron Adater/Bolt M22X1,5	Aluminum 6082

İsim/Name	İmza/Signature	Boyut / Dimensions-A4	Belge/Document : ECE R34	Ağırlık/Weight
Çizen / Drafter	Murat OKTAY	Malzeme/Material	5754 Almuninum	Tarih/Date
Onay /Approval		Parça Adı/Part Name	SCANIA FUEL TANK	Sayfa/Page
Ölçek / Scale		Açıklama/Explanation	670X700X735MM - 300LT.	Tolerance

Düzce Sağlam Depo