

| REV | REV DATE | DESCRIPTION | PICTURE NO |
|-----|----------|-------------|------------|
|-----|----------|-------------|------------|

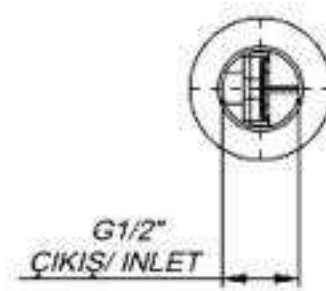
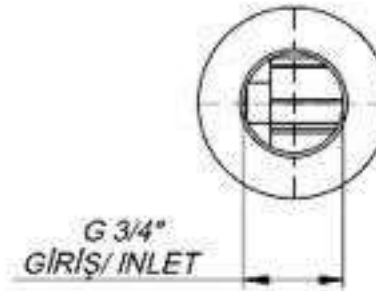
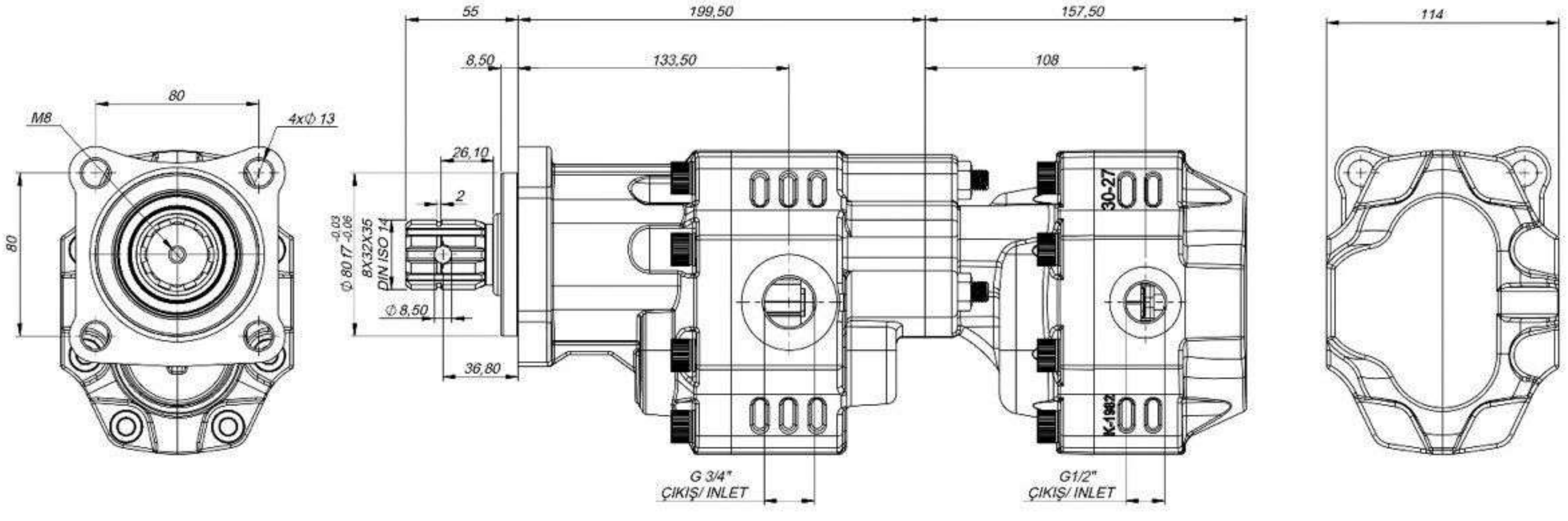

| Kod / Code | 998 4327 ISO TND BD | | |
|--|----------------------|------|------|
| Displacement iletim hacmi | cm ³ /rev | 43 | 27 |
| Max. Continuous pressure Maks. Sürekli Basıncı (100%) | bar | 280 | 290 |
| Max. Intermittent pressure Maks. Aralıklı Basıncı (20 sec.max) | | 290 | 300 |
| Max. Peak pressure Maks. Anlık Basıncı (6 sec.max) | | 300 | 310 |
| Max. Continuous speed Maks. Sürekli Hız | rpm | 2100 | 2600 |
| Max. Intermittent speed Maks. Aralıklı Hız | | 2600 | 3000 |
| Min speed Min Hız | | 300 | 300 |

PTO
Murat Makina
San.Tic.Ltd.Şti.
www.pto.com.tr
info@pto.com.tr