



**DISTRIBUTORI  
OLEODINAMICI**

**WMM10**

MANUALLY OPERATED  
DIRECTIONAL CONTROL VALVES

WMM10 SERIES MANUALLY OPERATED DIRECTIONAL CONTROL VALVES ARE DIRECT TYPE DIRECTIONAL SPOOL VALVES. THESE VALVES ARE USED TO THE START, STOP AND DIRECTION OF FLOW. THIS SERIES WITH DETENT OR RETURN SPRING ARE AVAILABLE.



**TECHNICAL DATA**

SIZE		10
MAX. FLOW RATE (L/MIN)		100
OPERATING PRESSURE (MPA)	A, B, P PORTS	31.5
	T PORT	16
WEIGHT (KG)		4.4
VALVE BODY (MATERIAL)		CASTING PHOSPHATING SURFACE



## CHARACTERISTIC CURVES

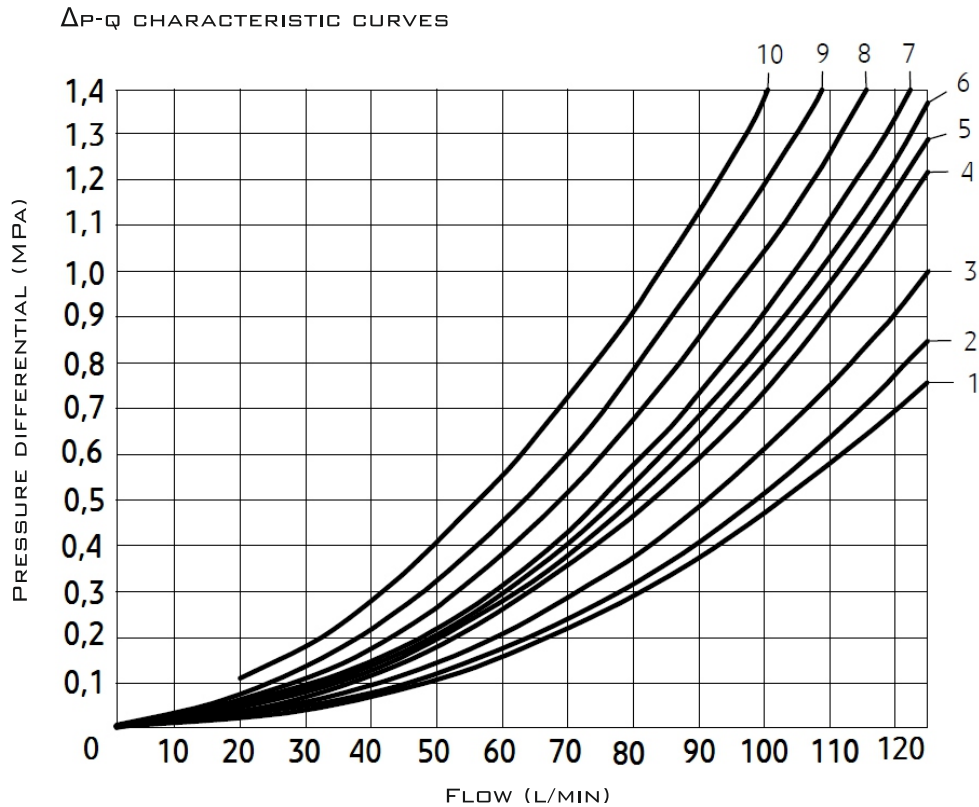

SPOOL SYMBOL	FLOW DIRECTION			
	P - A	P - B	A - T	B - T
A; B	3	3	-	-
C	3	3	4	5
D; Y	5	5	6	6
E	1	1	4	4
F	2	3	7	4
G	3	3	6	7
H	1	1	6	7
J	1	1	3	3
L	2	2	3	5
M	1	1	4	5
P	4	2	5	7
Q	1	2	1	3
R	3	6	4	-
T	3	3	6	7
U, V	2	2	3	3
W	2	2	4	5

9 CURVE - SPOOL SYMBOL "R" IN SHIFTED POSITION B → A;  
 3 CURVE - SPOOL SYMBOL "H" IN CENTRAL POSITION P → T;  
 4 CURVE - SPOOL SYMBOL "F" IN CENTRAL POSITION P → A;  
 9 CURVE - SPOOL SYMBOL "F" IN CENTRAL POSITION A → T,  
 SPOOL SYMBOL "F", "G" AND "T" IN CENTRAL POSITION P → T;  
 5, 8, 10 CURVES - SPOOL SYMBOL "P" IN CENTRAL POSITION P → B, B → T AND P → T.

SPOOL SYMBOLS

2-POSITION VALVES

3-POSITION VALVES

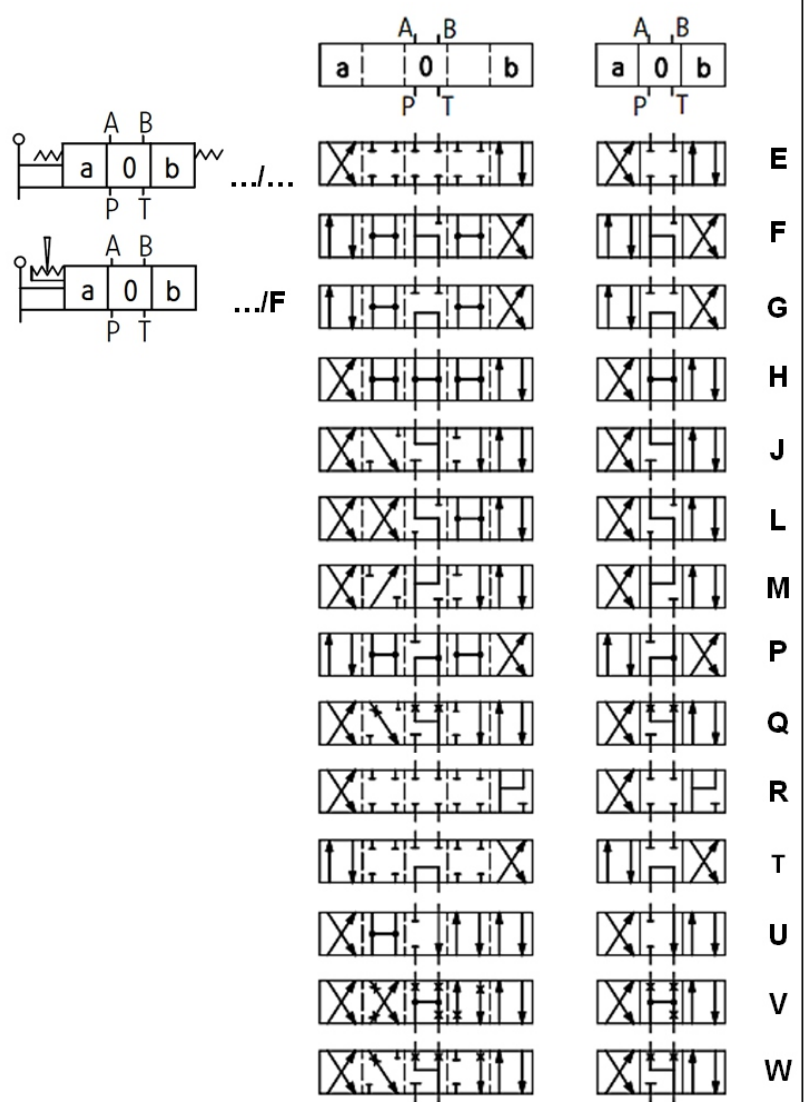
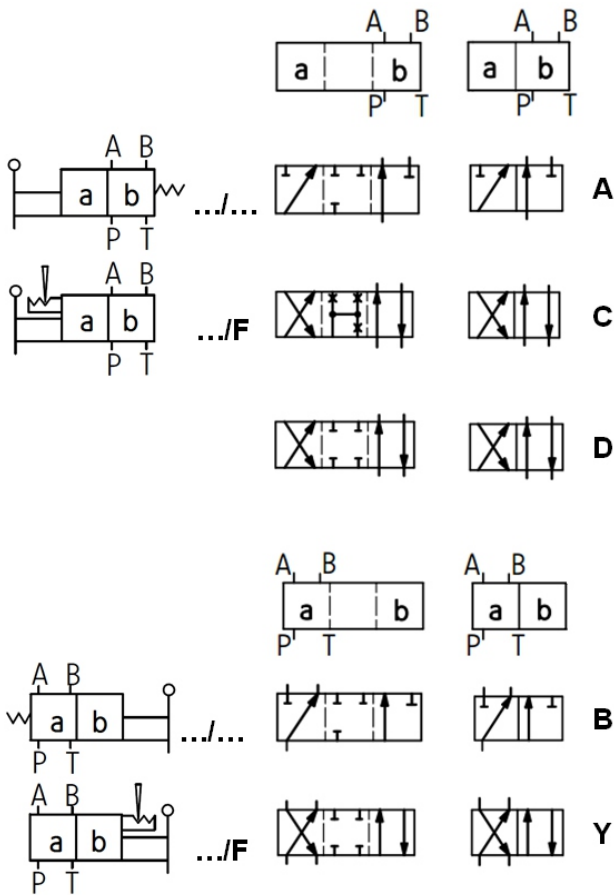

SEE ALSO:  
WMM6, WMM16,  
WMM25

## SUBPLATE INSTALLATION DIMENSIONS

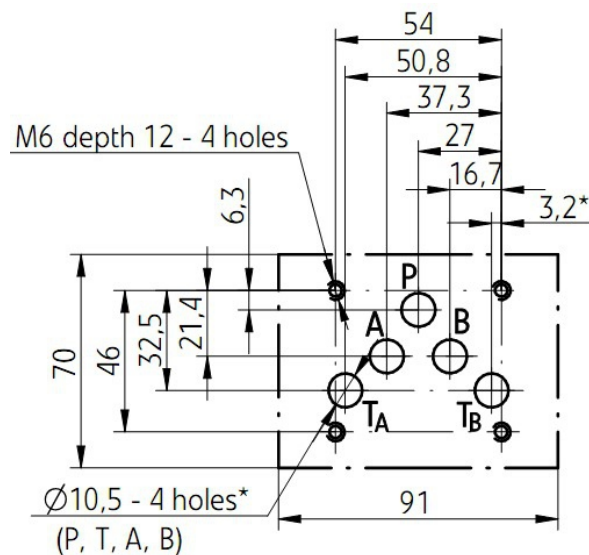
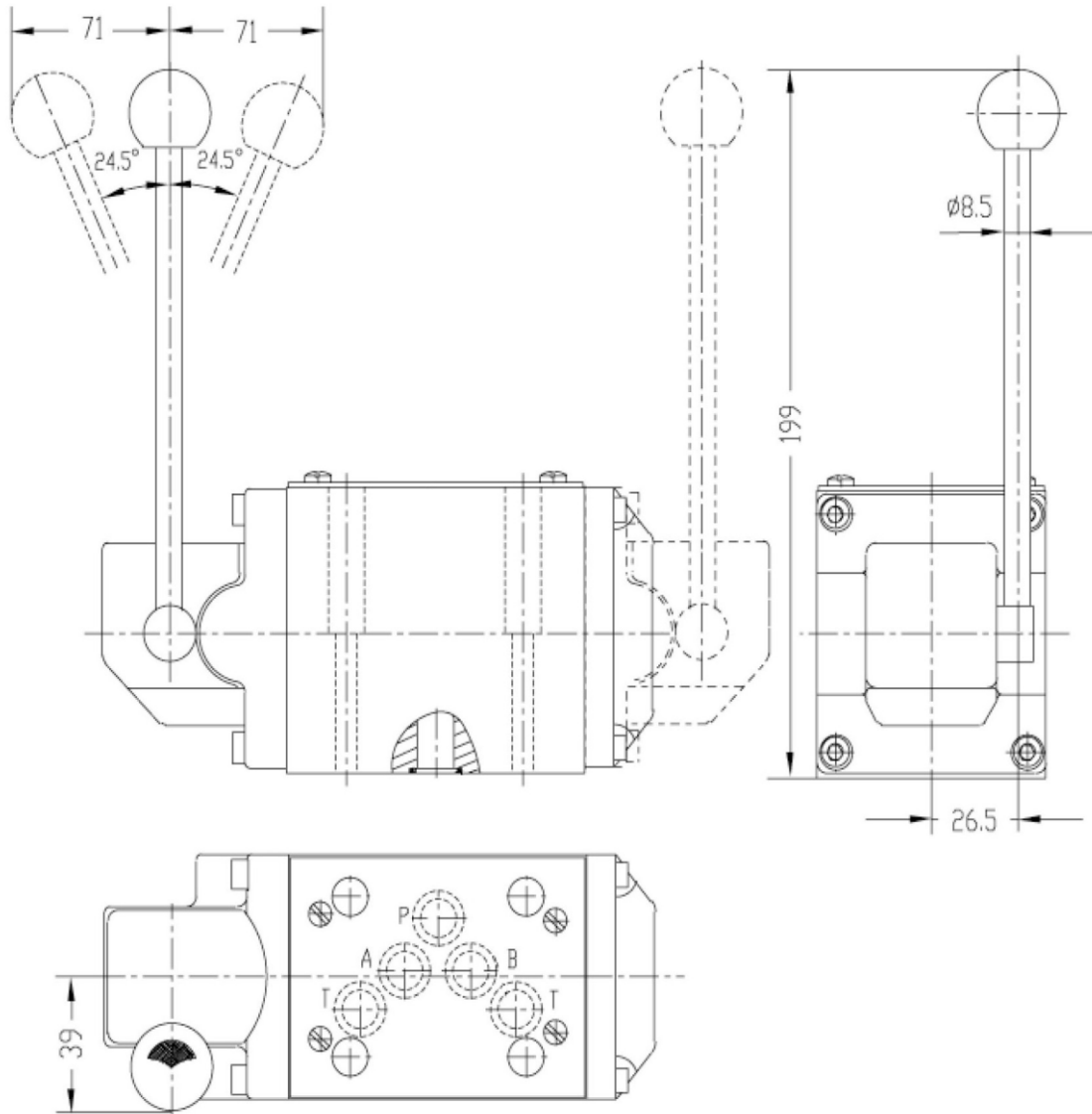

\* - CONNECTION WITH 1 HOLE T FROM PORT SIDE A OR B IS SUFFICIENT - HOLES T<sub>A</sub> AND T<sub>B</sub> ARE CONNECTED TO THE PORT T IN THE HOUSING OF DIRECTIONAL SPOOL VALVE



DISTRIBUTORI  
OLEODINAMICI

WMM10

MANUALLY OPERATED  
DIRECTIONAL CONTROL VALVES

ORDER CODE

	WMM	10							
--	-----	----	--	--	--	--	--	--	--

3=3-WAY  
4=4-WAY

10=10 SIZE

SPOOL TYPE

10=10 SERIES  
50=50 SERIES

NO CODE=SPRING RETURN WITHOUT DETENT  
F=DETENT WITHOUT SPRING RETURN

NO CODE=HANDLE ON SIDE OF  
PORT A  
L=HANDLE ON SIDE OF PORT B

NO CODE=MINERAL SUBSTANCE  
HYDRAULIC OIL  
V=PHOSPHATE EATER  
HYDRAULIC OIL

NO CODE=WITHOUT THROTTLE INSERT  
B0.8=THROTTLE 0.8 MM  
B1.0=THROTTLE 1.0 MM  
B1.2=THROTTLE 1.2 MM