



YLI ELECTRONIC



# Door Release Button W/Back Box

## Model:PBK-815

### Specification

- Size: 82Lx32Wx25H(mm)
- Current Rating: 3A@36VDC Max
- Suitable for Door: All Kind of the Narrow Door Frame
- Operating Humidity: 0-95% (relative humidity)
- Standard Structure: Alloy Plate, Steel Button
- Output Contact: NO/COM
- Mechanical Life: 500000 tested
- Operating temp: 10~+55°C(14-131F)
- Panel Material: Alloy Plate, Sandblast Finished
- Weight: 0.12kg

### Dimension Diagram

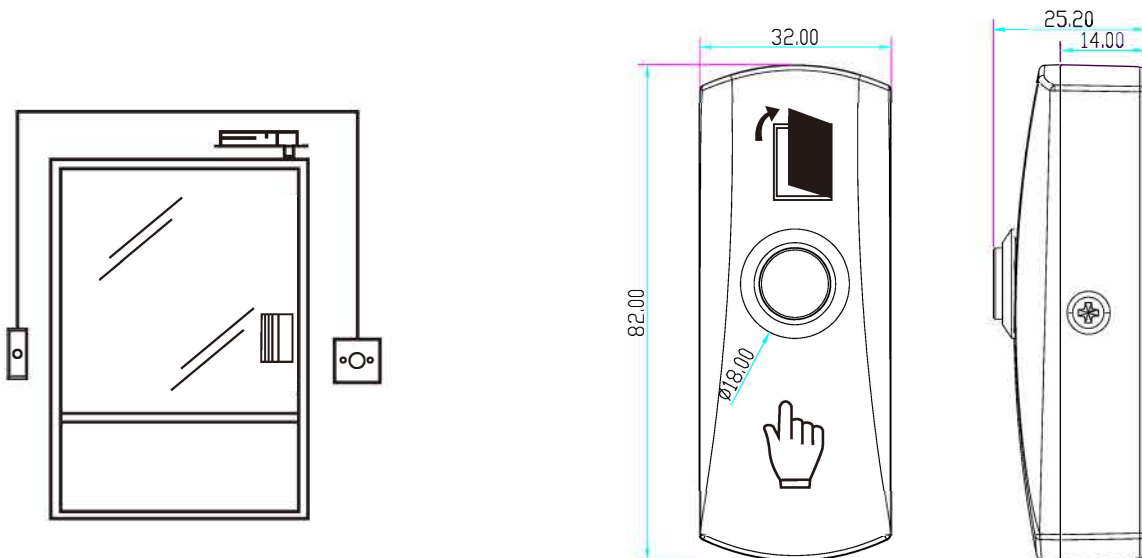

### Installation

