



FUEL MANAGEMENT SYSTEMS



DISPENSERS



KITS



PUMPS



METERS



NOZZLES

# CONNECTORS

## FEATURES

- STURDY STRUCTURE
- READY TO USE
- SEVERAL SOLUTIONS AVAILABLE

The range of fuel products is completed with a wide array of accessories for connecting products to allow the best performance. Starting from the 2" connectors and quick coupling.

### PERFORMANCE

2"

DRUM CONNECTOR

2"

QUICK COUPLING



2" DRUM CONNECTOR WITHOUT INTEGRATED VALVE



2" DRUM CONNECTOR WITH FLANGED AND INTEGRATED VALVE



2" DRUM CONNECTOR WITH INTEGRATED VALVE



2" QUICK COUPLING



### PACKAGING

CODE	PACKAGING			
	KG	MM	INCH	PCS/BOX
<b>2" CONNECTOR</b>				
F17163000	0,6	133X98X85		1
F17190000	0,6	133X98X85		1
F08934010	3,9	830X160X100		
F17163010	0,8	133X98X85		1
<b>2" QUICK COUPLING</b>				
R09160000	0,9	133X98X85		1
F0893000A	0,9	133X98X85		1
<b>EXTENSIBLE PIPE</b>				
F08934000	0,2	680X40X40		
F08934020	1,9	680X40X40		1



FILTRATION



TANK MONITORING



HOSE REEL



ACCESSORIES



MERCHANDISE



INDEX



ANY BIODIESEL



AIR



ANTIFREEZE



AdBlue®



BIODIESEL



DIESEL



FOOD



GASOLINE



GREASE



KEROSENE



OIL



WATER



WINDSCREEN

DIMENSIONS

COMPLETE KIT EXTENSIBLE SUCTION PIPE (1800MM)

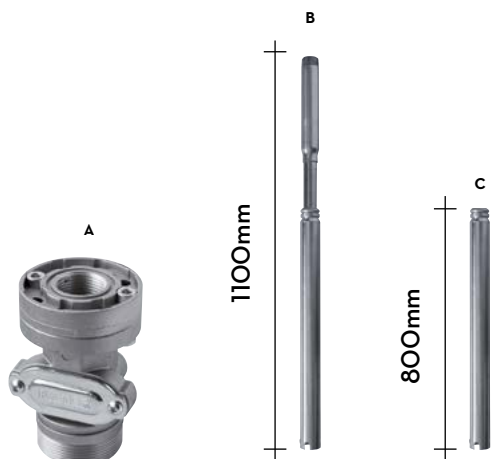

A: DRUM CONNECTOR FLANGED AND VALVE

B: EXTENSIBLE STEEL PIPE 1" BSP

C: STEEL PIPE 1" BSP

CODE: FO08934010

WEIGHT: 3,9 KG

PACKAGING: 820X150X100

IN THE BOX

- CONNECTOR
- INSTRUCTION MANUAL

DETAILS



MESH STRAINER



INTEGRATED VALVE

DIMENSIONS

EXTENSIBLE PIPE PLASTIC MADE



EXTENSIBLE STEEL PIPE 1" BSP

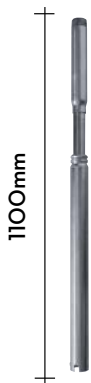

2" CONNECTOR



2" QUICK CONNECTOR

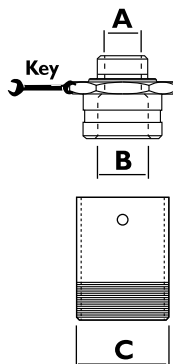

MATERIALS

- STEEL

Dimensions expressed in millimeters

TECHNICAL DATA

CODE	DESCRIPTION	FLUIDS TYPE	INTEGRATED VALVE	FILTER	INLET	OUTLET	THREADED FLANGE	A	B	C	KEY
					BSP	BSP	BSP	BSP	BSP	BSP	
<b>2" CONNECTOR</b>											
F17163000	DRUM CONNECTOR WITH INTEGRATED VALVE	D G K O	YES	YES	2"	-	NO	1"	1"	2"	-
F17190000	DRUM CONNECTOR WITHOUT INTEGRATED VALVE	D G K O	NO	YES	2"	-	NO	1"	1"	2"	-
F17163010	DRUM CONNECTOR WITH FLANGED AND INTEGRATED VALVE	D G K O	YES	YES	2"	1"	YES	1"	1"	2"	-
FO8934010	KIT EXTENSIBLE SUCTION PIPE 1" 1800MM	D G K O	YES	YES	2"	1"	YES	1"	1"	2"	-
<b>2" QUICK COUPLING</b>											
RO9160000	QUICK COUPLING 3/4"	D O	NO	NO	3/4"	1"	NO	M 3/4"	F 1"	M 2"	60
FO893000A	QUICK COUPLING 1"	D O	NO	NO	1"	1"	NO	M 1"	F 1"	M 2"	60
<b>EXTENSIBLE PIPE</b>											
FO8934000	EXTENSIBLE SUCTION PIPE 1" 940MM PLAST.	D G K O	-	-	1"	1"	-	-	-	-	-
FO8934020	EXTENSIBLE SUCTION PIPE 1" 1100MM STEEL	D G K O	-	-	1"	1"	-	-	-	-	-

CONNECTORS