

Standard – The Cantilever tail lift with load capacity 1000 kg to 3000 kg



Bär Cargolift – Lifting Performance.



# Bär Cargolift Standard

## For professional distribution transport with full versatility



Professional distribution transport has a wide range of requirements: High loads on high platforms, different drivers in multi-shift operation, varying framework conditions at the unloading sites, long service life, diverse vehicle types, but also tail lifts with relatively low platforms for standardised bodies in the medium payload market segment. And, not least: The Cargolift as a business card for the customer.

Thanks to over 40 years of experience, BÄR has the solution for all these requirements: Bär Cargolift Standard. With high load moments and extensive reserves, S4 Cargolifts provide the basis for long-term, efficient loading processes. Versatile fitment possibilities and application-specific equipment round out the offering. In the medium-heavy market segment, BC 1000 S2 and BC 1500 S4L score as weight-optimised tail lifts.



# Bär Cargolift Standard

## Vehicle-specific, usage-specific, customer-specific



The Standard product group is well-known for its versatile fitment possibilities on trucks, trailers and semitrailers, which is precisely detailed in the data sheet. In general, the Standard product group includes the following Cargolifts:



The all-rounders: with high load moment, high platforms and a wide range of mounting options on trucks of various weight classes with or without trailers, on trailers or semi-trailers:

- BC 1000 **S4**
- BC 1500 **S4**
- BC 2000 **S4**
- BC 2500 **S4**
- BC 3000 **S4**

When a variably positionable underun bar is required:

- BC 2000 **S4V**
- BC 2500 **S4V**



Payload-optimised for medium-duty trucks up to 18 t gross vehicle weight:

- BC 1000 **S2**
- BC 1500 **S4L**



For drawbar trailers with little overhang:

- BC 2000 **S4A**
- BC 2500 **S4A**



For trucks with a low coupling, these Cargolifts are available with hydraulic underun bar:

- BC 2000 **S4U**
- BC 2500 **S4U**

Standard Cargolifts are designed to accommodate these loads in consideration of the platform heights.

Load capacity

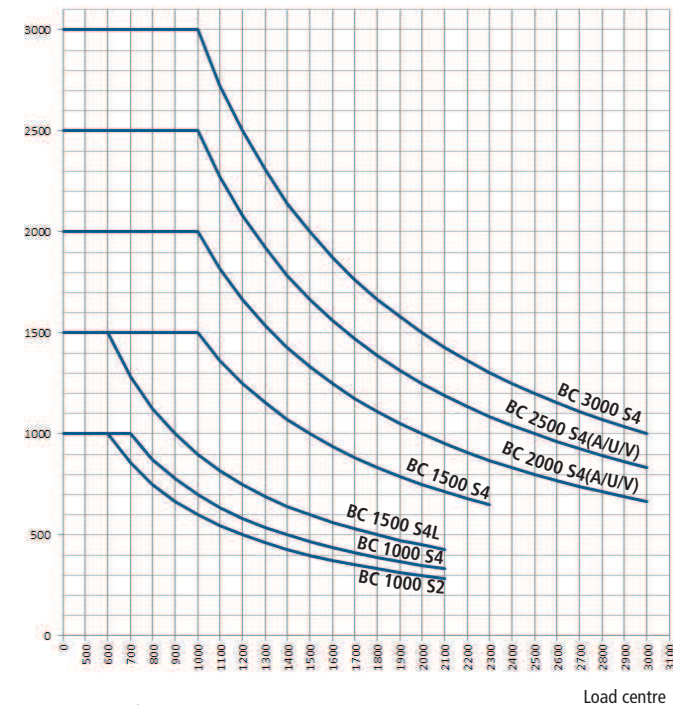

Load diagram of Standard product group



Website with product movie

# Bär Cargolift Standard BC 1000 S2 – When every kilo counts



Thanks to the low weight, starting at 291 kg, the BC 1000 S2 assures a positive payload balance. Two trolleys or one pallet can be loaded and unloaded quickly and easily with a pallet truck. This Cargolift also offers the well-known service-friendly and low-maintenance features.

Carrier vehicle	GVW/t min.	GVW/t max.
Truck	6,0 t	8,6 t

Load capacity	Load centre	Load moment
1000 kg	600 mm	6,0 kNm

## Aluminium platform

Platform system	Height	Width
BAplan45VLL	1610-2110 mm	2480 / 2520-2560 mm

## Weight with platform width 2520 mm

Platform height	Weight
1610 mm	281 kg
1810 mm	291 kg

The weight includes the standard scope of supply with mounting material, cables and under run bar.

## Technical data

The following drawing shows installation on U-profile frames. Other frame profiles (e.g. hat profile) may require installation adapters (optional) – see vehicle connection equipment.

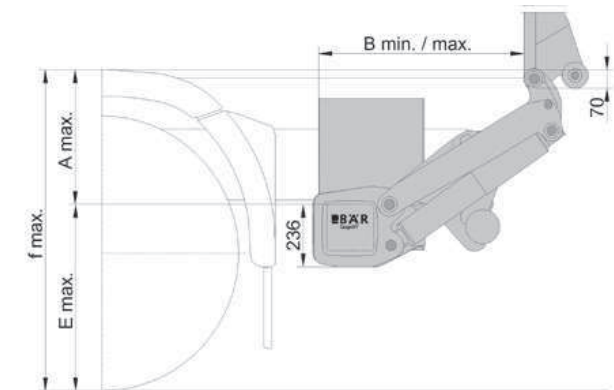

<b>Arm length</b>	<b>700 mm</b>
Lifting height $f_{max}$	1228 mm
Mass $A_{max}$	555 mm
Mass $E_{min}$ beladen	415 mm
Mass $E_{max}$	637 mm
Clearance $B_{min}$	720 mm
Clearance $B_{max}$	850 mm

Valid for vehicles from 8 t gross vehicle weight.

See standardised fitment drawing for fitment details and other carrier vehicles.

# Bär Cargolift Standard

## BC 1500 S4L – The lightweight with 4-cylinder technology



Only 360 kg with a platform height of 1810 mm and a load torque of 9.0 kNm! The BC 1500 S4L is a lightweight solution with four cylinders.

Carrier vehicle	GVW/t min.	GVW/t max.
Truck	6,0 t	18,0 t
Trailer	6,0 t	18,0 t
City semitrailer	15,0 t	18,0 t

Additional equipment may be required depending on the carrier vehicle – see vehicle connection equipment.

Load capacity	Load centre	Load moment
1500 kg	600 mm	9,0 kNm

### Aluminium platform

Platform system	Height	Width
BAplan45VLL	1610-2110 mm	2480 / 2520-2560 mm

Higher platforms on request

### Weight with platform width 2520 mm

Platform height	Weight
1610 mm	349 kg
1810 mm	360 kg
2010 mm	370 kg
2110 mm	375 kg

The weight includes the standard scope of supply with mounting material, cables and under run bar.

### Technical data

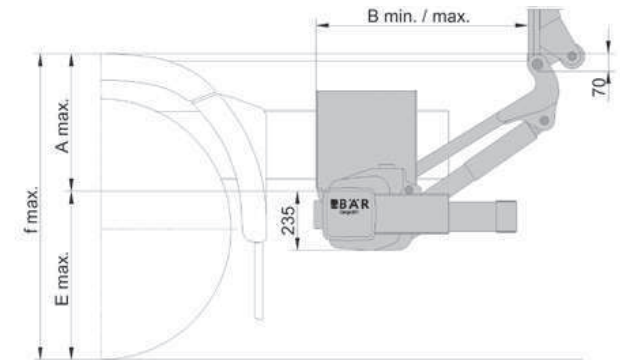

Arm length	720 mm*	800 mm	900 mm
Lifting height $f_{max}$	1200 mm	1285 mm	1350 mm
Mass $A_{max}$	590 mm	650 mm	715 mm
Mass $E_{max}$	620 mm	635 mm	635 mm
Clearance $B_{min}$	690 mm	740 mm	815 mm
Clearance $B_{max}$	870 mm	950 mm	985 mm

Valid for vehicles from 8 t gross vehicle weight with hydraulic, pneumatic or automatic suspension.

See standardised fitment drawing for fitment details and other carrier vehicles.

\* Arm length 720 mm cannot be combined with towing bracket for ball coupling.

# Bär Cargolift Standard

## BC 1000 S4 – The traditional Cargolift for the 7.5 t truck



The BC 1000 S4 is applicable for all sectors, particularly on trucks with a permissible total gross weight of 7.5 t. In addition to its solid load moment of 7.0 kNm, this Cargolift – like the entire S4 range – is well-known for its high level of reserves.

Carrier vehicle	GVW/t min.	GVW/t max.
Truck	6,0 t	8,6 t
Trailer	6,0 t	12,0 t
City semitrailers	15,0 t	18,0 t

Additional equipment may be required depending on the carrier vehicle – see vehicle connection equipment.

Load capacity	Load centre	Load moment
1000 kg	700 mm	7,0 kNm

### Aluminium platform

Platform system	Height	Width
BAplan45VLL	1610-2110 mm	2480 / 2520-2560 mm

### Weight with platform width 2520 mm

Platform height	Weight
1610 mm	332 kg
1810 mm	343 kg
2010 mm	353 kg
2110 mm	358 kg

The weight includes the standard scope of supply with mounting material, cables and under run bar.

### Technical data

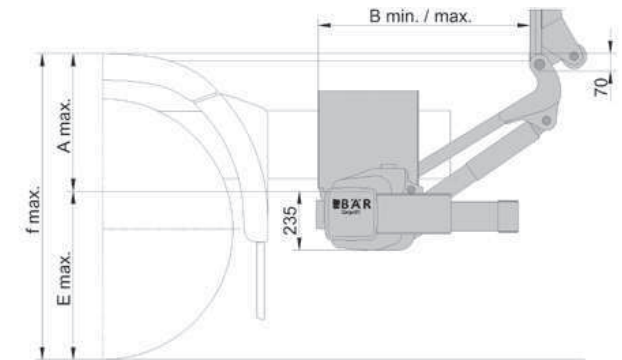

Arm length	800 mm	900 mm
Lifting height $f_{max}$	1385 mm	1460 mm
Mass $A_{max}$	650 mm	725 mm
Mass $E_{max}$	735 mm	735 mm
Clearance $B_{min}$	740 mm	805 mm
Clearance $B_{max}$	950 mm	985 mm

Valid for vehicles from 8 t gross vehicle weight.

See standardised fitment drawing for fitment details and other carrier vehicles.

# Bär Cargolift Standard

## BC 1500 S4 – The best-selling Cargolift in the Bär product range!



It is right at home in bulk goods, distribution and general cargo transport – and is also cherished in other segments. With the high load moment of 15.0 kNm and the proven power reserves, the versatile installation and equipment options, the BC 1500 S4 is easily equipped for every use.

Carrier vehicle	GVW/t min.	GVW/t max.
Truck	7,5 t	18,0 t
Trailer	6,0 t	18,0 t
City semitrailer	15,0 t	28,0 t

Additional equipment may be required depending on the carrier vehicle – see vehicle connection equipment.

Load capacity	Load centre	Load moment
1500 kg	1000 mm	15,0 kNm

### Aluminium platform

Platform system	Height	Width
BAplan45VLL	1610-2310 mm	2480 / 2520-2560 mm
BAplan45VL	1610-2310 mm	2520-2560 mm
AFplan	1960-2310 mm	2300 / 2480-2560 mm

### Weight with platform width 2520 mm

Platform height	BAplan40VLL	BAplan40VL	AFplan
1610 mm	431 kg	-	-
1810 mm	441 kg	-	-
2010 mm	-	464 kg	505 kg
2110 mm	-	475 kg	516 kg

The weight includes the standard scope of supply with mounting material, cables and under run bar.

### Technical data

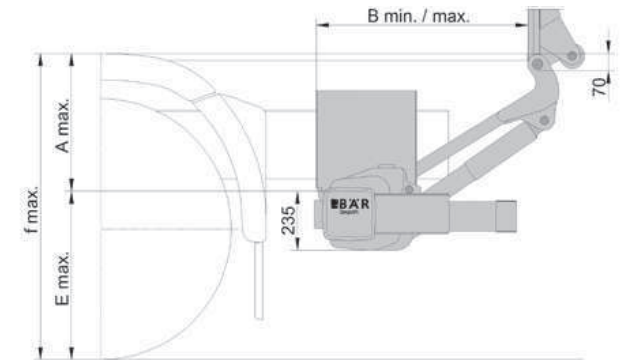

Arm length	800 mm	900 mm	1000 mm
Lifting height $f_{max}$	1275 mm	1355 mm	1430 mm
Mass $A_{max}$	665 mm	745 mm	820 mm
Mass $E_{max}$	610 mm	610 mm	610 mm
Clearance $B_{min}$	720 mm	780 mm	850 mm
Clearance $B_{max}$	925 mm	1030 mm	1110 mm

Valid for vehicles from 8 t gross vehicle weight with hydraulic, pneumatic or automatic suspension.

See standardised fitment drawing for fitment details and other carrier vehicles.

# Bär Cargolift Standard

## BC 2000 / 2500 S4 – For professional distribution transport



With its high load moment, the sturdiest platform systems and versatile fitment and equipment possibilities, the BC 2000 / 2500 S4 is the long-term companion in beverage and food distribution.

Carrier vehicle	GVW/t min.	GVW/t max.
Lkw	12,0 t	25,0 t / 32,0 t
Anhänger	12,0 t	18,0 t / 24,0 t
Semitrailer	28,0 t	40,0 t

Additional equipment may be required depending on the carrier vehicle – see vehicle connection equipment.

Load capacity	Load centre	Load moment
2000 kg	1000 mm	20,0 kNm
2500 kg	1000 mm	25,0 kNm

### Aluminium platform

Platform system	Height	Width
BAplan45VL	1810-2510 mm	2520-2560 mm
BAplan50VL	1810-3010 mm	2520-2560 mm
AFplan	1960-2810 mm	2300 / 2480-2560 mm

### Weight with platform width 2520 mm\*

Platform height	BAplan45VL	BAplan50VL	AFplan
2110 mm	512 kg	545 kg	553 kg
2210 mm	517 kg	552 kg	559 kg
2610 mm	–	580 kg	583 kg
3010 mm	–	607 kg	–

The weight includes the standard scope of supply with mounting material, cables and under run bar.

\* BC 2500 S4 is about 5 kg heavier

### Technical data

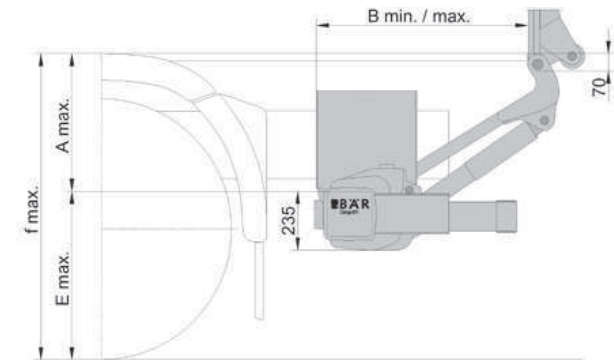

Arm length	800 mm	900 mm	1000 mm	1100 mm
Lifting height	1275 mm	1355 mm	1430 mm	1510 mm
$f_{max}$				
Mass $A_{max}$	665 mm	745 mm	820 mm	900 mm
Mass $E_{max}$	610 mm	610 mm	610 mm	610 mm
Clearance $B_{min}$	720 mm	780 mm	885 mm	950 mm
Clearance $B_{max}$	895 mm	990 mm	1140 mm	1150 mm

Valid for vehicles from 8 t gross vehicle weight with hydraulic, pneumatic or automatic suspension.

See standardised fitment drawing for fitment details and other carrier vehicles.



# Bär Cargolift Standard

## BC 3000 S4 – The super-strong Cargolift



The BC 3000 S4 is the strongest, largest Cargolift in the product range: The extraordinary load moment of 30.0 kNm can lift all sorts of loads on the platform with a height of up to 3010 mm! The equipment portfolio provides you with optimal support according to your needs.

Carrier vehicle	GVW/t min.	GVW/t max.
Truck	18,0 t	32,0 t
Trailer	18,0 t	24,0 t
Semitrailer	28,0 t	40,0 t

Additional equipment may be required depending on the carrier vehicle – see vehicle connection equipment.

Load capacity	Load centre	Load moment
3000 kg	1000 mm	30,0 kNm

### Aluminium platform

Platform system	Height	Width
BAplan50VL	2110-3010 mm	2520-2560 mm

### Weight with platform width 2520 mm

Platform height	Weight
2110 mm	706 kg
2210 mm	713 kg
2610 mm	741 kg
3010 mm	769 kg

The weight includes the standard scope of supply with mounting material, cables and under run bar.

### Technical data

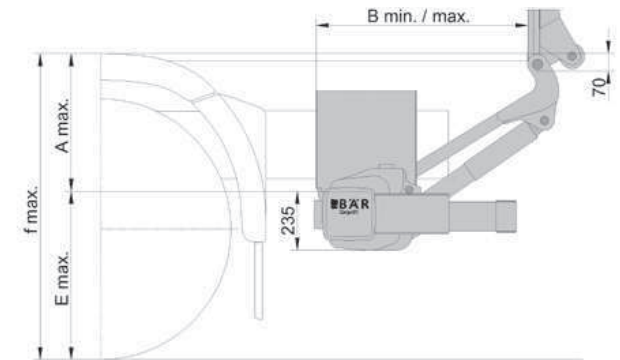

Arm length	800 mm	900 mm	1000 mm
Lifting height $f_{max}$	1260 mm	1330 mm	1410 mm
Mass $A_{max}$	650 mm	720 mm	800 mm
Mass $E_{max}$	610 mm	610 mm	610 mm
Clearance $B_{min}$	740 mm	810 mm	870 mm
Clearance $B_{max}$	900 mm	1050 mm	1110 mm

Valid for vehicles from 8 t gross vehicle weight with hydraulic, pneumatic or automatic suspension.

See standardised fitment drawing for fitment details and other carrier vehicles.

# Bär Cargolift Standard BC 2000 / 2500 S4A – When the overhang is short



Installation on steering trailers usually leaves little room for a tail lift – therefore the BC S4A only requires a clearance of 580 mm at the rear of the vehicle. With a high load moment and extensive variety of equipment.

Carrier vehicle	GVW/t max.
Trailer	18,0 t
City semitrailer	28,0 t

Additional equipment may be required depending on the carrier vehicle – see vehicle connection equipment.

Load capacity	Load centre	Load moment
2000 kg	1000 mm	20,0 kNm
2500 kg	1000 mm	25,0 kNm

### Aluminium platform

Platform system	Height	Width
BAplan45VL	1810-2510 mm	2520-2560 mm
BAplan50VL	2110-3010 mm	2520-2560 mm
AFplan	1960-2810 mm	2300 / 2480-2560 mm

### Weight with platform width 2520 mm

Platform height	BAplan45VL	BAplan50VL	AFplan
2110 mm	517 kg	537 kg	558 kg
2210 mm	521 kg	544 kg	562 kg
2610 mm	–	572 kg	578 kg
3010 mm	–	600 kg	–

The weight includes the standard scope of supply with mounting material, cables and under run bar.

### Technical data

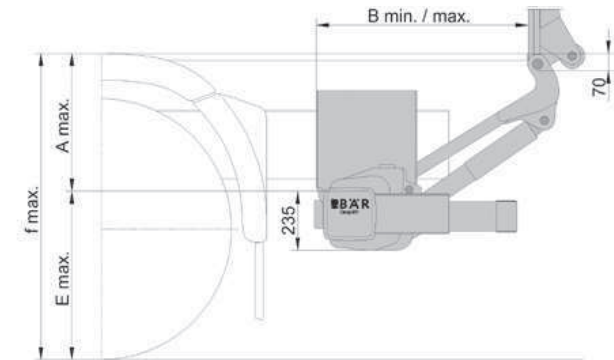

Arm length	800 mm*	900 mm*	1000 mm
Lifting height $f_{max}$	1335 mm	1450 mm	1540 mm
Mass $A_{max}$	750 mm	840 mm	930 mm
Mass $E_{max}$	585 mm	610 mm	610 mm
Clearance $B_{min}$	630 mm	630 mm	670 mm
Clearance $B_{max}$	820 mm	900 mm	910 mm

Valid for vehicles from 8 t gross vehicle weight with hydraulic, pneumatic or automatic suspension.

See standardised fitment drawing for fitment details and other carrier vehicles.

\*BC 2500 S4A only available in arm length 800 mm and 900 mm

# Bär Cargolift Standard

## BC 2000 / 2500 S4U – For trucks with deep coupling



Normal and deep coupling combined with a taillift? The BC S4U makes it possible, because all components guarantee a drawbar freedom of 180°/6°. The under run bar is simply positioned above in trailer operation – in solo operation it is conveniently held on the ground.

Carrier vehicle	GVW/t max.
Truck with low coupling	25,0 t

Additional equipment may be required depending on the carrier vehicle – see vehicle connection equipment.

Load capacity	Load centre	Load moment
2000 kg	1000 mm	20,0 kNm
2500 kg	1000 mm	25,0 kNm

### Aluminium platform

Platform system	Height	Width
BAplan45VL	1810-2510 mm	2520-2560 mm
BAplan50VL	2110-3010 mm	2520-2560 mm
AFplan	1960-2810 mm	2300 / 2480-2560 mm

### Weight with platform width 2520 mm\*

Platform height	BAplan45VL	BAplan50VL	AFplan
2110 mm	643 kg	669 kg	684 kg
2210 mm	658 kg	676 kg	699 kg
2610 mm	–	704 kg	759 kg
3010 mm	–	732 kg	–

The weight includes the standard scope of supply with mounting material, cables and under run bar.

\* BC 2500 S4U is about 20 kg heavier

### Technical data

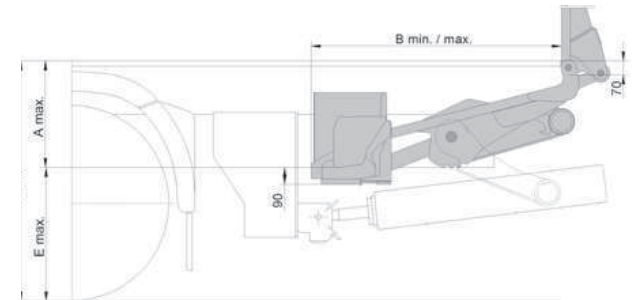

Arm length	1000 mm	1100 mm
Lifting height $f_{max}$	1410 mm	1410 mm
Mass $A_{max}$	795 mm	765 mm
Mass $E_{max}$	705 mm	770 mm
Clearance $B_{min}$	1097 mm	1238 mm
Clearance $B_{max}$	1287 mm	1386 mm

Valid for vehicles from 8 t gross vehicle weight with hydraulic, pneumatic or automatic suspension.

See standardised fitment drawing for fitment details and other carrier vehicles.

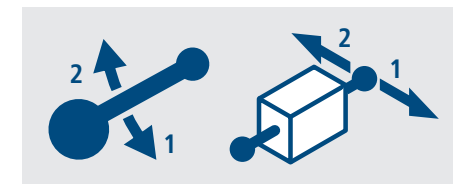

**Hydraulic under run bar** (standard) enables the hydraulic operation of the under run bar from the control box Bär Control EVO.

# Bär Cargolift Standard BC 2000 / 2500 S4V – With under run bar in variable positioning



As a new option with 2000 kg / 2500 kg load capacity, the BC S4V offers an under run bar in variable positioning: Vertically in four levels, horizontally in seven levels. This enables, for example, use of trailers with a cranked drawbar. The equipment range and high load moment of the S4 are still provided.

Carrier vehicle	GG/t min.	GG/t max.
Truck	12,0 t	25,0 t
Trailer	12,0 t	18,0 t
Semitrailer	28,0 t	40,0 t

Load capacity	Load centre	Load moment
2000 kg	1000 mm	20,0 kNm
2500 kg	1000 mm	25,0 kNm

### Aluminium platform

Platform system	Height	Width
BAplan45VL	1710-2510 mm	2520-2560 mm
BAplan50VL	1810-3010 mm	2520-2560 mm
AFplan	1960-2810 mm	2300 / 2480-2560 mm

### Weight with platform width 2520 mm

Platform height	BAplan45VL	BAplan50VL	AFplan
2110 mm	542 kg	575 kg	583 kg
2210 mm	547 kg	582 kg	589 kg
2610 mm	–	610 kg	613 kg
3010 mm	–	637 kg	–

The weight includes the standard scope of supply with mounting material, cables and under run bar.

### Technical data

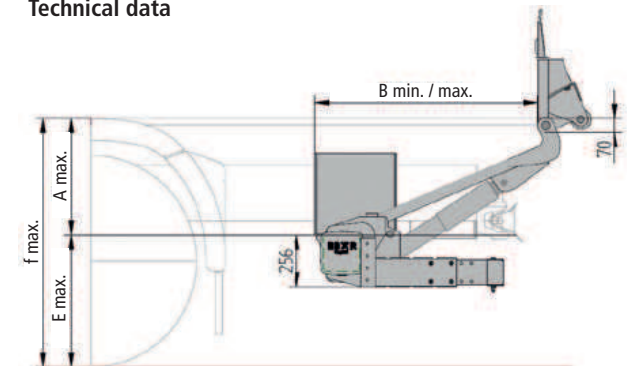

Arm length	800 mm	900 mm	1000 mm	1100 mm
Lifting height $f_{max}$	1400 mm	1545 mm	1680 mm	1755 mm
Mass $A_{max}$	665 mm	745 mm	825 mm	900 mm
Mass $E_{max}$	735 mm	800 mm	855 mm	855 mm
Clearance $B_{min}$	720 mm	785 mm	840 mm	905 mm
Clearance $B_{max}$	915 mm	1015 mm	1110 mm	1115 mm

See fitment drawing for fitment details.

Applicable under run bar requirements must be observed!

Ball coupling not possible.

\*\* in 50 mm increments

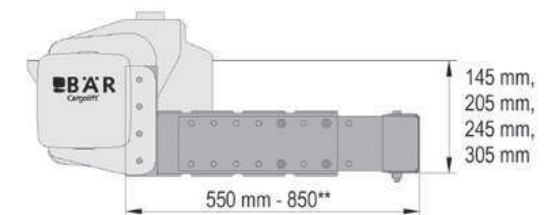

# Bär Cargolift Standard Equipment



## Lifting unit



**Cathodic dip coating** (RAL 9005 - standard) of all steel parts as long-term anti-corrosive protection with out additional top coat. With frequent cleaning of the vehicle, **cathodic dip coating + powder coating** (optional) in RAL colour of your choice.

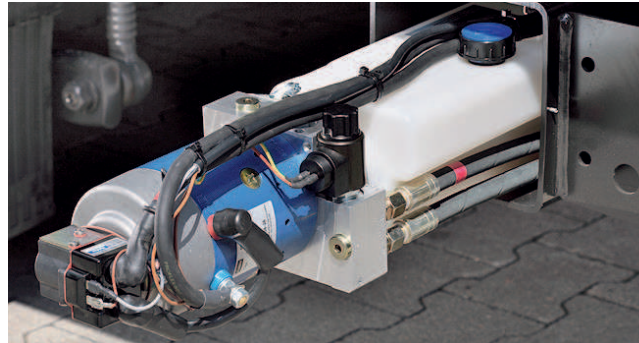

**Power pack** and **control unit** are safely protected in the beam (standard). Motor with thermal circuit breaker protecting against overheating and fire. Simple **emergency operation** of the four basic functions by pushbutton.



Standard **hydraulic oil** requires annual oil change before the winter. For longer oil change interval (every 3 years) as well as for use at low temperatures of up to -45°C: Biodegradable **Syntofluid oil** (option).



Hydraulic cylinder with **protective tube** or **bellow** (standard) as protection from stone chipping and corrosion. Consistently fast, motorised opening by means of double-action tilting cylinders – even in winter.

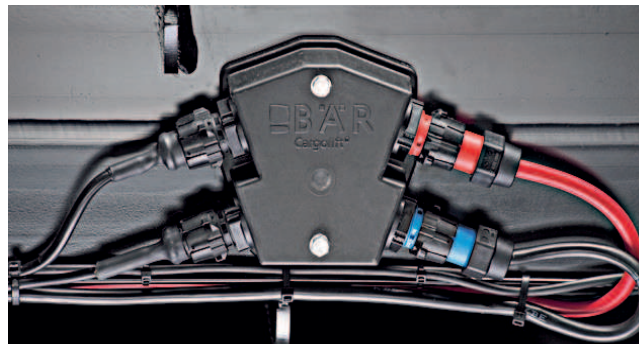

**VDHH electrical interface** (standard) for simple electrical connection.



**Ground rollers** (standard) protect the platform from mechanical abrasion with ground contact.

# Bär Cargolift Standard Equipment



## Platform



Natural **aluminium** rear platform side (standard) or powder-coated in RAL colour of your choice (option) and **anodised** platform (option) available.

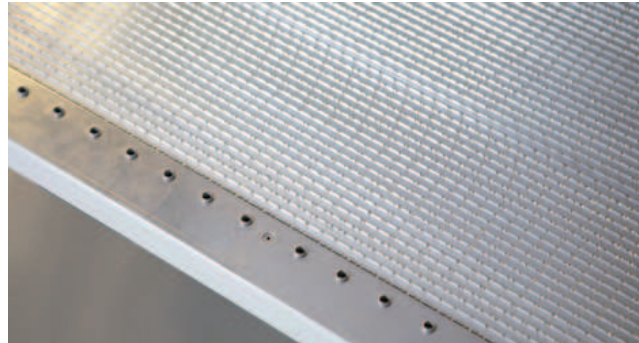

More safety and more traction on the platform with the **TracGrip** and **SideGrip** anti-slip platform surfaces (standard, R11) – even with wet surface. **TracGrip Plus** is optionally available with increased R13 anti-slip resistance.



Bär **RamGuard** (option) made of stainless steel for protection of platform corners during ramp use.



**Ground rollers** (standard) protect the platform from mechanical abrasion with ground contact.



Bär **SilentGrip** (option, R11) for increased noise insulation during night-time or morning deliveries in residential areas.

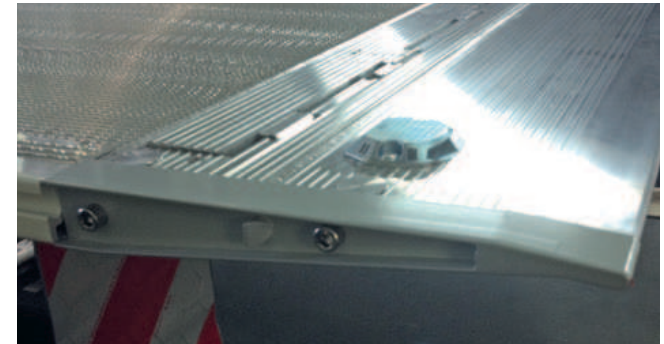

**SteelTop** (option BAplan45VL, standard BAplan50VL) made out of massive stainless steel for protection of platform corners during intensive ramp use.

# Bär Cargolift Standard Equipment



## Platform



**Platform edging** (option) for infinitely variable attachment of a **side loading ramp** (option) available without track guiding (length 1000 mm; available widths 600 / 734 / 845 mm).



**Side loading ramp** (option) with track guiding (length 980 mm, width 734 mm).

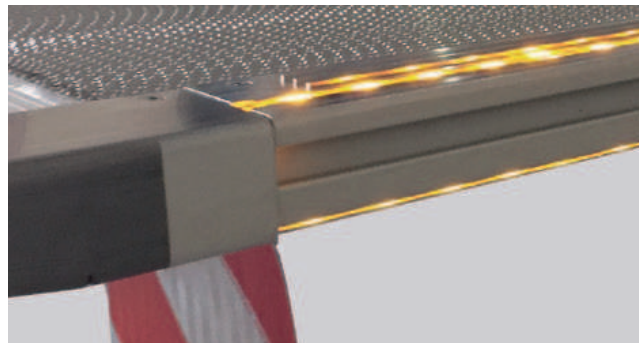

**NightGuide** (option) for maximum visibility. LED strips integrated on both sides at the top and bottom in the platform edging for side loading ramp. Available for BAplan45VL(L) height 1,610-2,410 mm / BAplan-50VL height 2,010-2,810 mm.



Durable **CargoFlash** LED flashing light (standard) with high light intensity and very good sidewise emission with low current consumption. **Protector angles** for flashing lights (options) are available.

## Platform – trolley stops

Bär Cargolift offers various **trolley stops** depending on the platform system which is in use. All trolley stops are distinguished by the highest roll-over resistance thanks to a double floor. Operating levers are always outside of the operating range

Trolley stops with two switch positions allow:

- Position (1) – Loading – flap opens automatically after being driven over with trolleys
- Position (2) – Unloading – flap locks after tramping down

Alternatively, trolley stops can be opened with one switch position via a tumbler switch and closed again by tramping down.

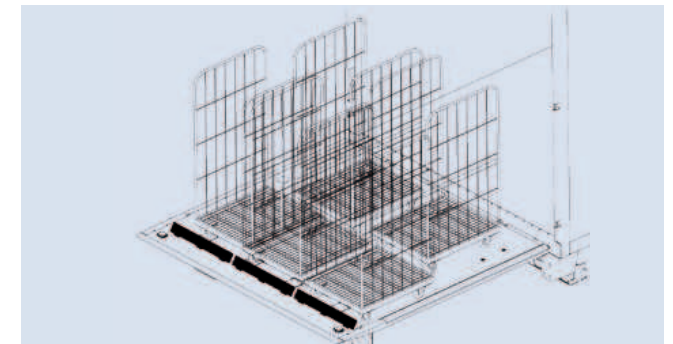

Exemplary positioning of three trolleys in the platform tip and two trolleys at the side.

## Platform – trolley stops / recesses (option) in the platform tip

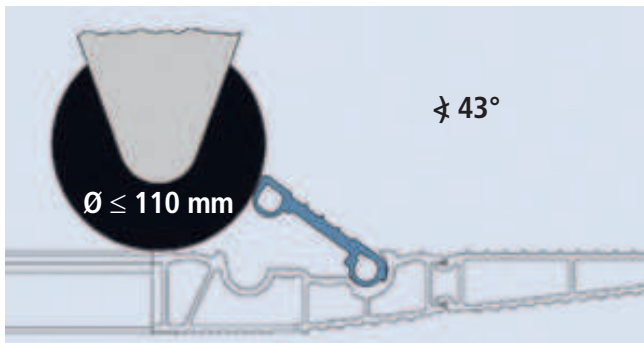

**Trolley stop rd** as with operating lever and two switch positions. The trolley stop flaps open individually. Available as 2rd for two trolleys for platform system BAplan45VLL with minimum width 1950 mm and flap width 750 mm.

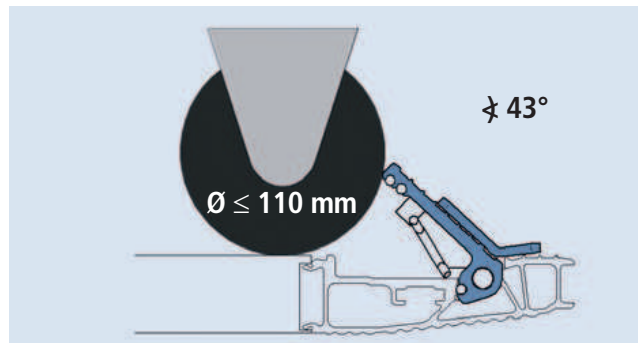

**Trolley stop Rs** with a tumbler switch and one switch position. The trolley stop flaps open individually. Available as 2Rs for platform system BAplan45/50VL with minimum width 2340 mm and flap width 1012 mm or as 3Rs with platform width 2450 mm and flap 745 mm.

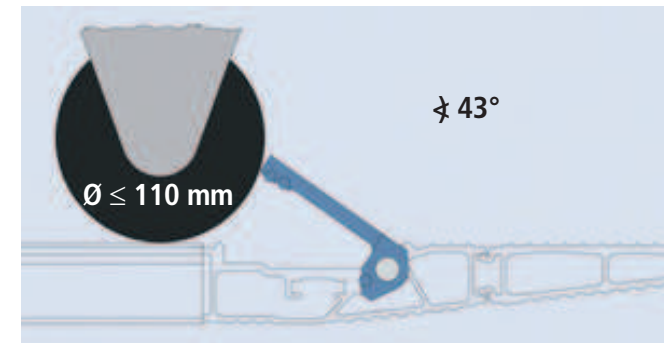

**Trolley stop Rx** with a tumbler switch and two switch positions. The trolley stop flaps open simultaneously. Available for platform system BAplan45/50VL and AFplan. As 2Rx with platform width 2300 mm, 3Rx with platform 2500 mm and 5Rx with height 2110-2510 mm and width 2440 mm. Flap width 745 mm, for 2Rx also 890 mm.

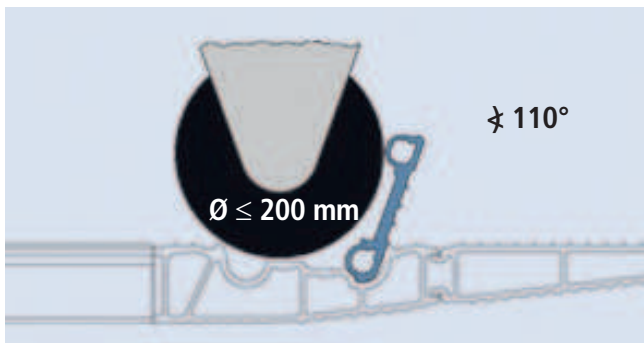

**Trolley stop ad** with operating lever and two switch positions. The trolley stop flaps open individually. Available as 2ad for two trolleys for platform system BAplan45VLL with minimum width 1950 mm and flap width 750 mm.

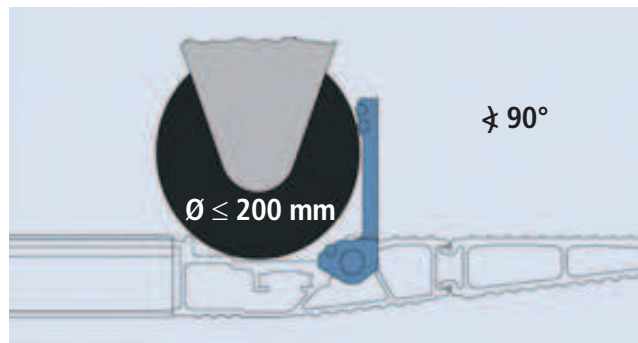

**Trolley stop Ax** with a tumbler switch and one switch position. The trolley stop flaps open individually. Available as 2Ax for platform system BAplan45/50VL with platform width 2300 mm and flap width 800 mm or as 3Ax with platform width 2520 mm and flap 750 mm.



**Machined wheel recesses** are milled from a single piece, available for platform system BAplan45VL and AFplan, minimum platform width 2400 mm. Available as two pairs for two trolleys



# Bär Cargolift Standard Equipment



## Trolley stops / recesses (option) lateral



**Roller cavities** with double floor. Available for platform system BAplan45VL and AFplan as a pair for one trolley on the left in direction of travel or two pairs on the right and left. Can be combined with machined wheel recesses as well as with trolley stop Rs, Rx and Ax. Minimum platform height of 2160 mm.

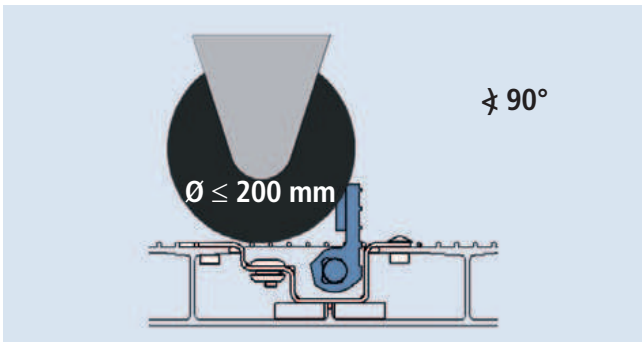

**Side trolley stop L** with a tumbler switch and one switch position. Available for one trolley on the left for platform system BAplan45/50VL with minimum height of 2110-2510 mm and flap width 885 mm. Can be combined with trolley stop Rs, Ax or Rx.

## Platform



Bär **CargoBridge** (option – except for BC 1000 S4 / BC 3000 S4) for fitment of platform behind doors with twist locks.

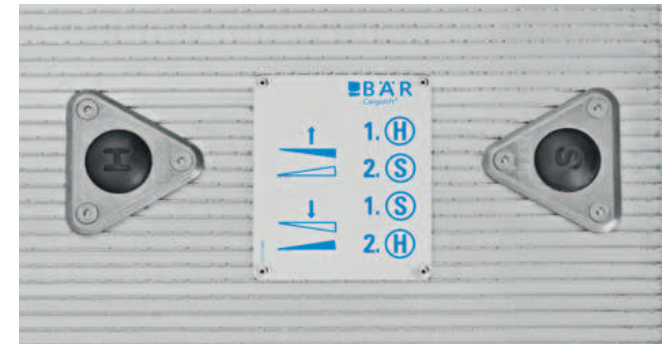

Bär **foot control** (standard) offers simple operation by means of two foot switches in addition to a safe location.



**CargoSeal** sealing system (option) for reliable rear end closure with body-closing platform.

# Bär Cargolift Standard Equipment



## Control elements



**Bär Control EVO** (standard) is intuitive in use, durably constructed and can be easily operated with gloves thanks to the vertically and horizontally operating joysticks.

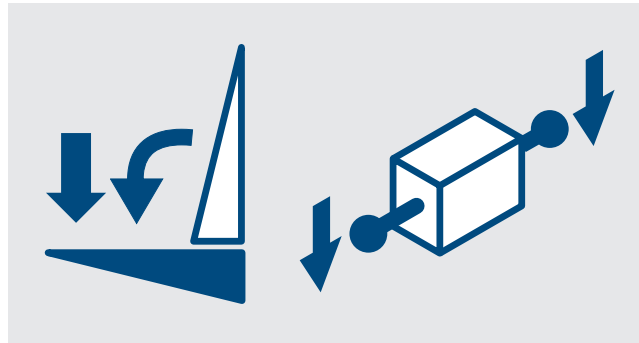

With the **QuickShift** function (standard S4) you save valuable time with simultaneous opening and lowering.

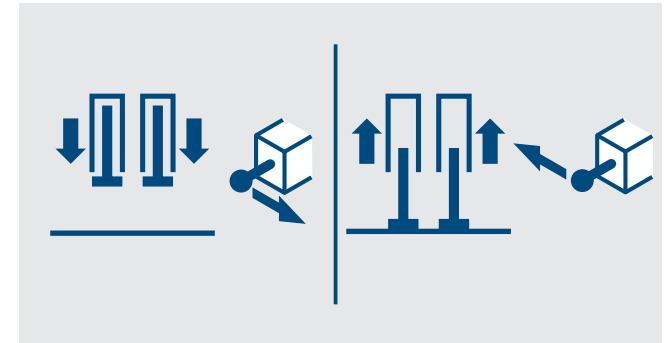

Uncoupled central-axle drawbar trailers are locked on the drawbar and rear by means of **hydraulic jack legs** (option). Jack legs can be controlled separately or together. **Mechanical** version (option) also available.

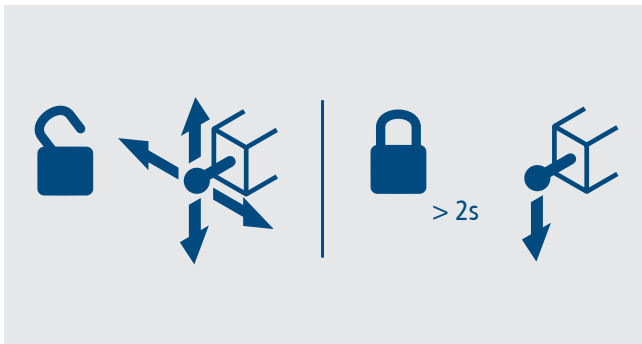

**SwitchKey** (option, series on S4A) enables the Cargolift to be switched on and off with the control lever, thus preventing any undesired operation.

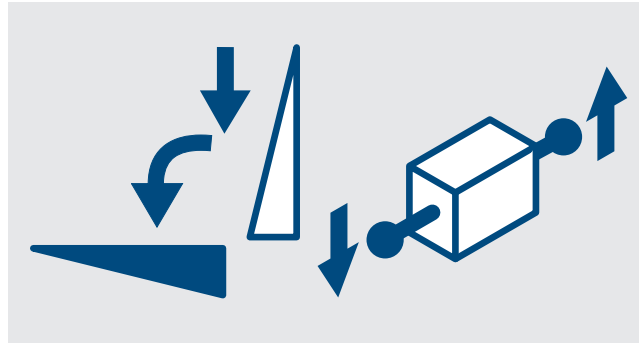

**SoftLock** (option with BC 1500 S4 or higher) the platform automatically hooks under the loading guard rails - safely and error-free. Optional for mounting on closing platforms.

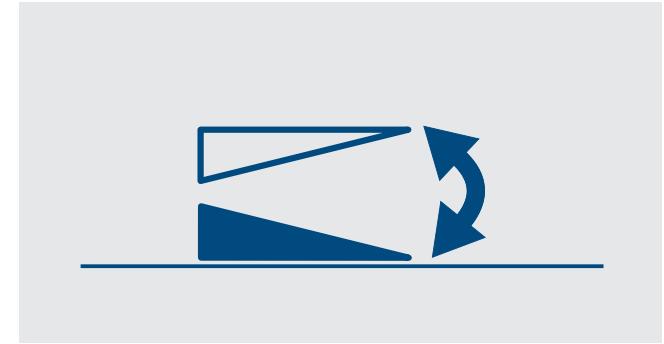

**Automatic tilt down** on the ground (standard) for safe loading. The platform returns to its original position when tilting up by means of memory effect.

# Bär Cargolift Standard Equipment



## Control elements



**Protection cover** (option) for Bär Control EVO made of stainless steel.



**Pushbutton plate 3+1** (option) for mounting outside in the body wall.



**Pushbutton plate with 2 functions** (option) for fitment inside the body.



**External electrical key switch** (option) for mounting on control box holder. Prevents any undesired operation as an alternative to the SwitchKey.



**Control box** (standard S2, option S4L) for operation of four basic functions of the Cargolift.

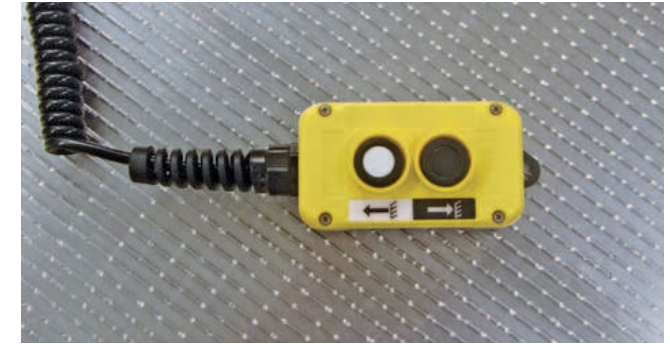

**Cable remote control** (option) with two functions, incl. platform marking for the assigned operating position. Socket for cable remote control pre-fitted on the control box or available for fitment inside the body.

# Bär Cargolift Standard Equipment



## Control elements



**Bär SmartControl Basic** (option) for CE-compliant operation of all four basic functions by radio.



**Bär SmartControl cabin control** (option) for control of the Cargolift from the cabin by Bär SmartControl Plus with docking station.



**Bär SmartControl Plus** (option) with additional functions (e.g. hydraulic under run bar). Optionally available with **rechargeable hand-held transmitter and docking station** – cabin switch via radio and starter interruption.



**Bär rolling gate control** (option) unit automatically opens and closes the rolling gate of the body depending on the Cargolift operation so that the cold air is kept inside the body and operation is made easier.

## Vehicle connection



**SmartCharge SC-VEHH** electronically controlled charging system (option) as standardised plug connection for arbitrary swapping of tractor vehicle and trailer. Intelligent control unit assures sufficient battery fold at the unloading point. Indication of faults via blinking signal.



Reliable power supply with the Bär **battery case** (option) – compact mounting on under run bar. Also available as Bär **BatteryBox** (option) for side fitment under the body.

# Bär Cargolift Standard Equipment



## Vehicle connection



**Towing bracket for ball coupling** (option S4) with European type approval for the parts (parts ABE), D-value 29 kN, max. support load 350 kg, weight approx. 20 kg. Advance electrical preparation required on the vehicle!

**Ball coupling** optionally available.

Calculation of the maximum admissible trailer load of the towing bracket:

$$\text{trailer load in t} = \frac{\text{D-value in kN} \times \text{GVW vehicle in t}}{(9,81 \text{ m/s}^2 \times \text{GVW vehicle in t}) - \text{D-value in kN}}$$

In case the carrier vehicle or the ball coupling lead to a lower admissible trailer load, the lowest value is determining.

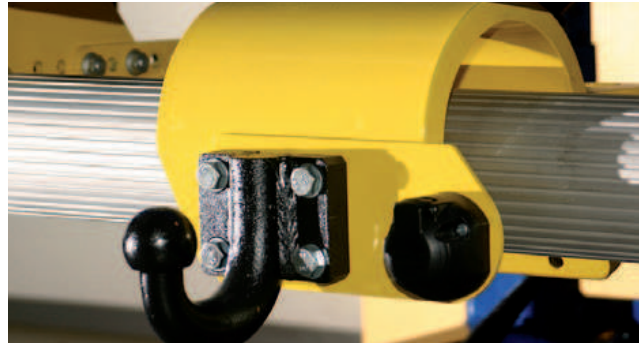

**Towing bracket for ball coupling** (option BC 1000 S2) with European type approval for the parts (parts ABE), D-value 26.9 kN, drawbar load max. 250 kg, weight approx. 45 kg. Advance electrical preparation required on the vehicle! **Ball coupling** optionally available.

# Bär Cargolift Standard Equipment



Piek version (Option BC 1000/1500 S4, BC 2000 S4(A/V) – includes the following equipment, if not identified as an option)



The Bär **SilentGrip** noise-reducing platform surface has a thicker application in the Piek version and is also provided on the heel of the platform as well as – if present – the trolley stops and CargoSeal stop rails.

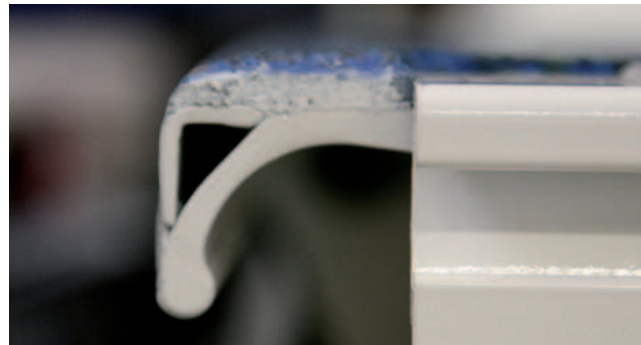

The platforms of Standard Cargolifts are rounded towards the body in order to enable closing. A „pothole“ arises at this position when it is driven over, so the S4 Cargolift in Piek version is equipped with a **platform heel**.

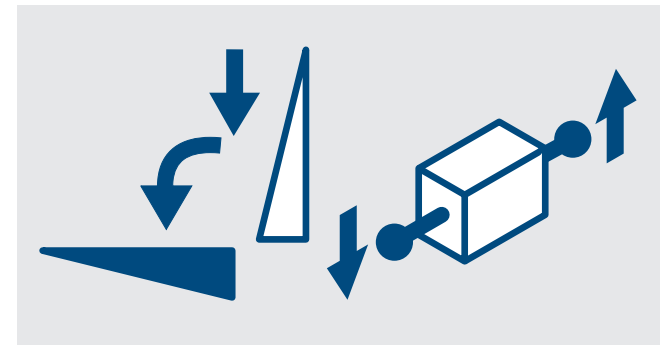

**SoftLock** automatically hooks the platform under the loading guard rails – safely and error-free. With S4 Cargolifts in Piek version, the heel of the platform requires the SoftLock function.



**Ground rollers** with additional rubber coating on the floor dampen noise development. All S4 Cargolifts in Piek version have a **low-noise power pack**.

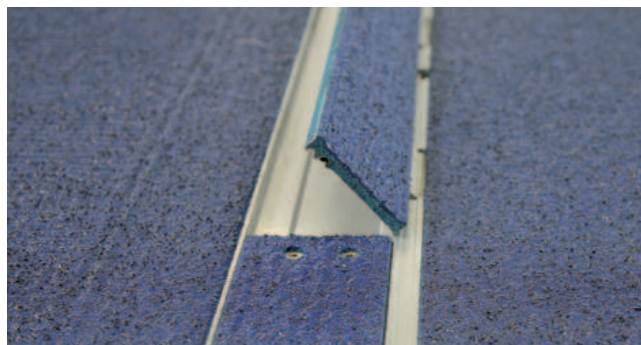

**Trolley stop Rs** (option) in Piek version with SilentGrip coating, internal damping elements and plastic slide bearings. Flap width: 1012 mm for 2Rs, 745 mm for 3Rs. Available for all S4 Cargolifts in Piek version. In addition L lateral possible.



Bär **CargoSeal** body sealing in Piek version (option) dampens the stop of the platform on the body when closing. With rubber buffers as a lift vibration stop when raising.

The family company – medium-sized, owner-managed, sustainable



Bar Baltic Production UAB in Šiauliai, Lithuania

Additional production site since 2021

Highly automated sheet metal part production and production of welded steel assemblies

Energy-efficient building A++ as well as CO2-neutral energy consumption of all welding processes



Gerd Bär GmbH in Heilbronn, Germany

Traditional location since 1981

Customer-oriented consulting competence for professional Users

Core competence aluminium platform production

Efficient assembly lines for lifting mechanisms

Logistics centre for Cargolifts and Bär original spare parts

Control centre for all corporate functions

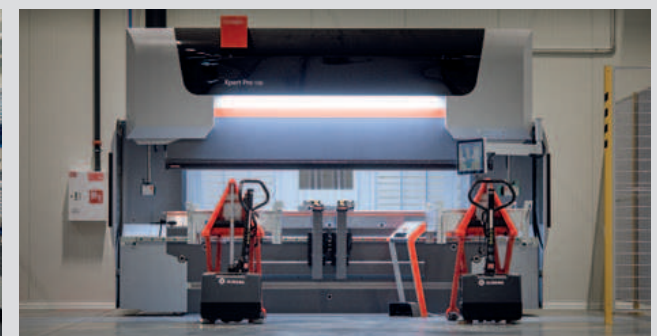

# Bär Cargolift – On the spot for you with sales and service!



## BÄR companies for sales and service:

-  Gerd Bär GmbH, Germany
-  Bär Cargolift France SAS, France
-  Bar Cargolift Canada Inc., Canada
-  Bär Praha s.r.o., Czech Republic
-  Bär Cargolift Polska Sp. z o.o., Poland
-  Bär Cargolift RUS OOO, Russia

## BÄR sales offices for sales and service in the following countries:

-  Austria
-  Netherlands (BeNeLux)
-  Italy
-  Hungary (South-Eastern Europe)
-  Denmark
-  Sweden (Scandinavia)

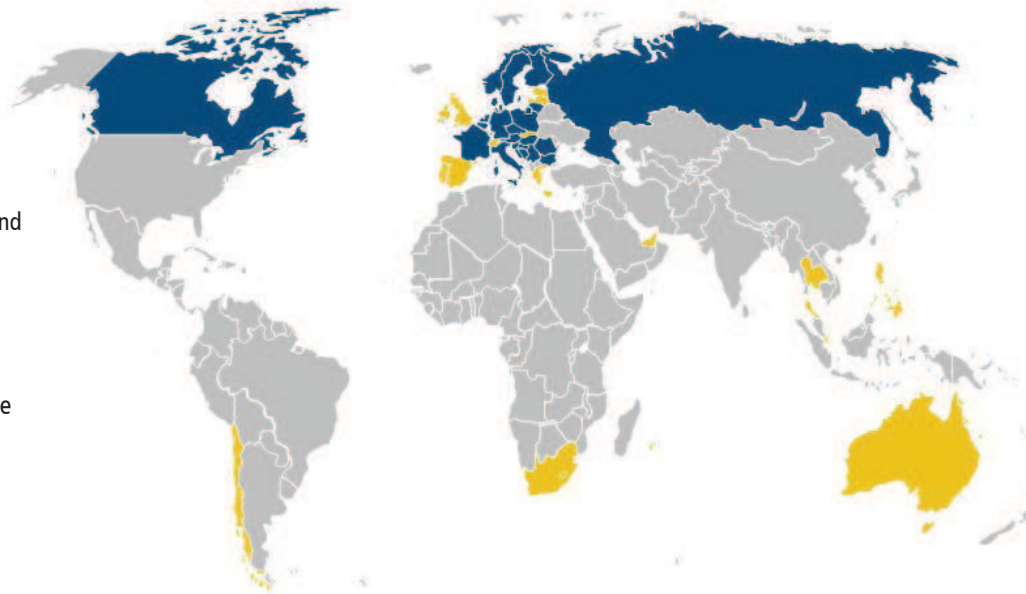

## In the countries marked in yellow, BÄR works together with local partners:

-  Switzerland
-  Spain
-  Portugal
-  Great Britain
-  Greece
-  Baltics
-  Chile
-  South Africa
-  United Arab Emirates
-  Thailand
-  Australia
-  Philippines



# Bär Cargolift – Lifting Performance.

The world of transport and logistics is becoming more and more competitive and complex. In order to work successfully in this business, customer oriented solutions with maximum efficiency are required. And last but not least high performance tail lifts.

Bär considers the tail lift as an integral part of an overall system which is being optimized user specifically to maximum performance. Only with a deep understanding of the various transportation tasks an ideal product solution can be created.

The core competence of Bär Cargolift is the continuous enhancement of the performance of tail lifts.

The customer of Bär Cargolift can be sure to receive a solution that supports his work in an optimal way. He gets supported in all phases of the product life cycle from ordering to mounting and from handling to service – based on partnership.

Bär Cargolift has shaped the industry over decades with innovative solutions. Solid technology that can be used easily and safely has created the decisive advance versus the competition.

## Bär Cargolift – Lifting Performance.



Find out more about “Bär Cargolift – Lifting Performance. Since 1981.” – the family business, its innovations and its continuous development at: [www.lifting-performance.com](http://www.lifting-performance.com)



Gerd Bär GmbH · Industriegebiet Böllinger Höfe · Pfaffenstraße 7 · D 74078 Heilbronn  
Fon +49 7131 2877-992 · Fax +49 7131 2877-912 · vk@baer-cargolift.de · www.baer-cargolift.com