

Installation Manual
VISIO TELESCÓPICO



manusa

INSTALLATION MANUAL

VISIO TELESCÓPICO



Read thoroughly all of these instructions before using the unit.

This manual includes all the necessary information required to install the product.

Keep this manual in a safe place for future reference.

0 ÍNDICE

1 DEFINITIONS AND PREREQUISITES

- 1.1 Symbol Description
- 1.2 Product Marking
- 1.3 Legend of the Necessary Tools Required for Assembly
- 1.4 Placement. Physical and Environmental Requirements
- 1.5 Placement. Pre-wiring Requirements
- 1.6 Training Requirements for Technicians

2 SLIDING OPERATOR ASSEMBLY

- 2.1 Cut Formula Table
- 2.2 Track Set Assembly: Slow Leaf
- 2.3 Track Set Assembly: Fast Leaf
- 2.4 Cut Formula Table; Clear Width Stiles
- 2.5 Assembly of Clear Width Stiles

3 CENTRAL OPERATOR ASSEMBLY

4 APPENDIXES

- 4.1 EC Declaration of Conformity



1 DEFINITIONS AND PREREQUISITES

This manual contains instructions for the safe and correct installation of the product. Please read it carefully and keep it in a safe place for future reference. When in doubt, please contact the Service Centre (see back of manual).

For your own safety, please observe at all times the technical instructions described in this manual. **manusa** will not be held responsible for any damages and faults caused as a result of not adhering to these instructions.





1.1 Symbol Description

The symbols that appear in this manual and/or on the machine are listed below:





	ELECTRICAL HAZARD. No work must be performed inside the machine unless it has been previously disconnected from the power supply.
	GENERAL DANGER. Improper use may cause injuries to people and damage the machine.
	IMPORTANT WARNING. Strictly adhere to the indications provided with this symbol.



1.2 Product Marking

The product should include a marking similar to the one displayed. Should this not be the case, please report it to the Service Centre (see back of manual).

Fabricante/Manufacturer: Manusa Door systems		manusa 	
País/Country: España		P/N: A00525	
Año fabricación/Manufacturing year: 2013		R: 000 S/N: 12345678	
Modelo/Model: Visio			
Tensión/Voltage: 220-240V/50-60Hz			
Potencia/Power: 265W		www.manusa.com	
		Microp. Vers. 312 15	T.24h: 180
Carga máxima: Mas. total weight: 2200N			

1.3 Legend of the Necessary Tools Required for Assembly

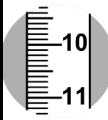
	Open-end wrenches 13, 10
	Drill bits Ø9, Ø5, Ø3
	Phillips screwdriver
	Allen key 3-4-5

	Tape measure
	Saw
	Spirit Level

1.4 Placement. Physical and Environmental Requirements

manusa automatic doors must be installed in locations that meet the following conditions:

- Smooth, even and levelled floors.
- Stable walls with sufficient load capacity.
- Levelled partitioning.
- Absence of vibrations and impacts on the door area.
- Service temperature: -15°C to +50°C.
- Relative air humidity: the electric and electronic components of operators manufactured to work in tropical climates receive a surface treatment that protects them from air humidity.

1.5 Placement. Pre-wiring Requirements

For the assembly of **manusa** power-operated doors, a pre-wiring electrical system with the following elements must be in place:

 The diagram shows the standard wiring for the elements that the operator includes as standard.

- 1** Power input:
 - 16mm corrugated tube.
 - Cables 3x1.5mm² (Phase, Neutral, Earth)
 - Two-pole circuit breaker, min. 4A
- 2** Sensors:
 - Cables supplied with the accessory.
- 3** Selector
 - 16mm corrugated tube.
 - Shielded cable 4x0.25mm²

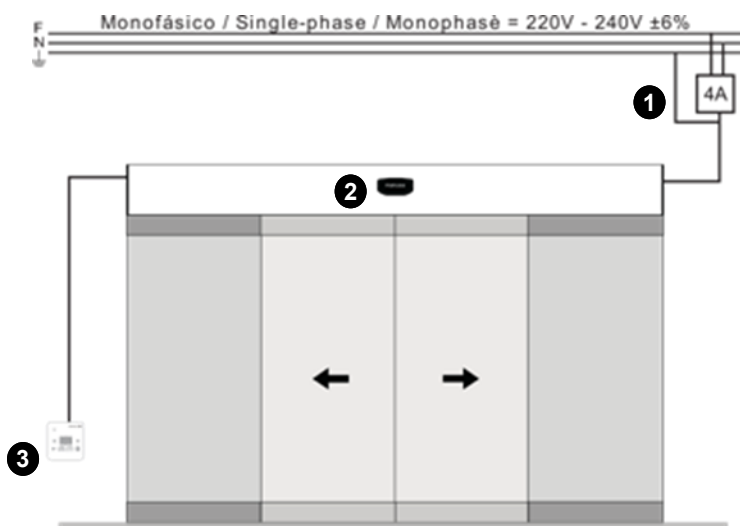

1.6 Training Requirements for Technicians

The installation of all **manusa** products, as well as any tasks related to maintenance, setting, adjustment, etc. Must be performed by technical personnel authorised by **manusa**. These are the main objectives of the training process for all authorised installation technicians:

- To know how to use the handling and lifting equipment.
- To be able to correctly handle loads.
- To learn how to use individual protection equipment.
- To be able to apply the recommendations of the Low Voltage Regulations.
- To have deep technical knowledge of all **manusa** products.
- To be familiar with the reference and application guidelines for **manusa** products and services.

2 SLIDING OPERATOR ASSEMBLY

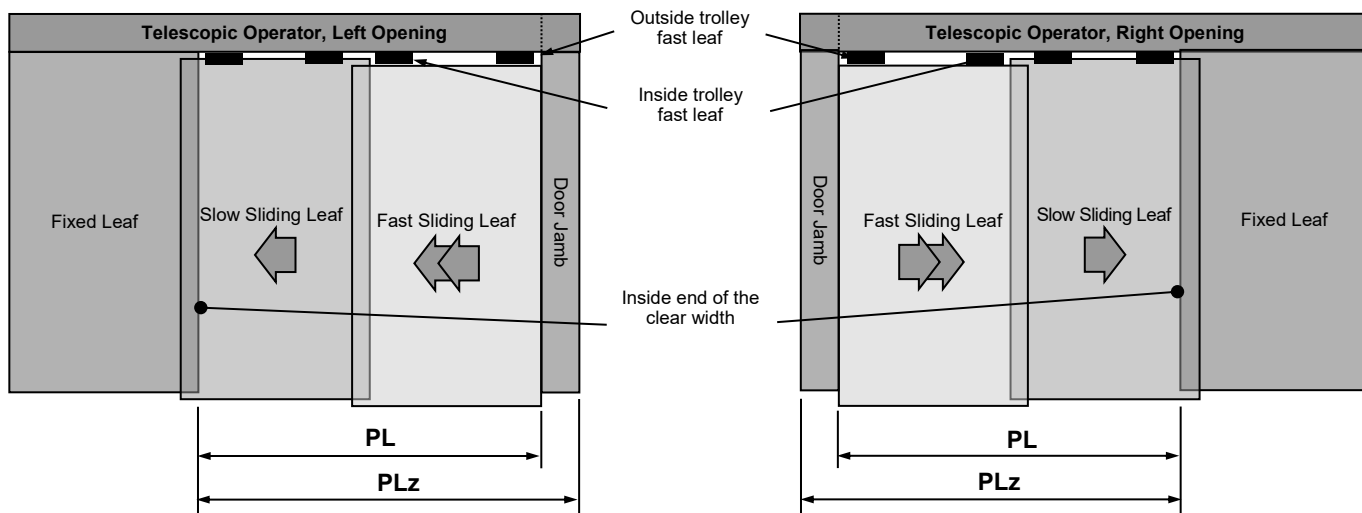

The Visio Telescopic Operator incorporates two track rails, with a leaf sliding on each one. The slow leaf slides along the telescopic stile (closer to the wall) and the fast leaf slides along the main profile of the Visio Operator, assembled on top of the telescopic stile (further from the wall).

The operator measurement will increase depending on the type of leaf used (See table)



Leaves	PLz
F20	PL
D20	PL
E20	PL+25
I30	PL+45

2.1 Cut Formula Table

STILE	SIDE		MEETING	
	With fixed leaves	Without fixed leaves	With fixed leaves	Without fixed leaves
 E20/I30				Lop - 5
 E20/I30				Lop -15
 E20/I30				Lop -15

2.2 Track Set Assembly: Slow Leaf

2.2A Let us start by assembling the slow part of the operator.

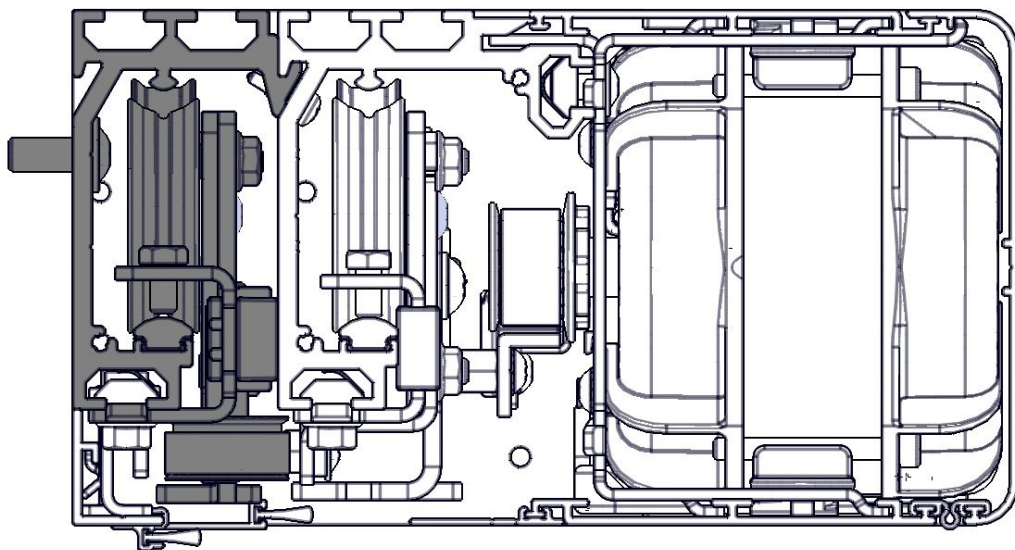

2.2B Cut the telescopic stile to the necessary measurements depending on the door leaves. Drill holes to attach the operator following the recommended measurements. Cut the sealing and the track stile and assemble

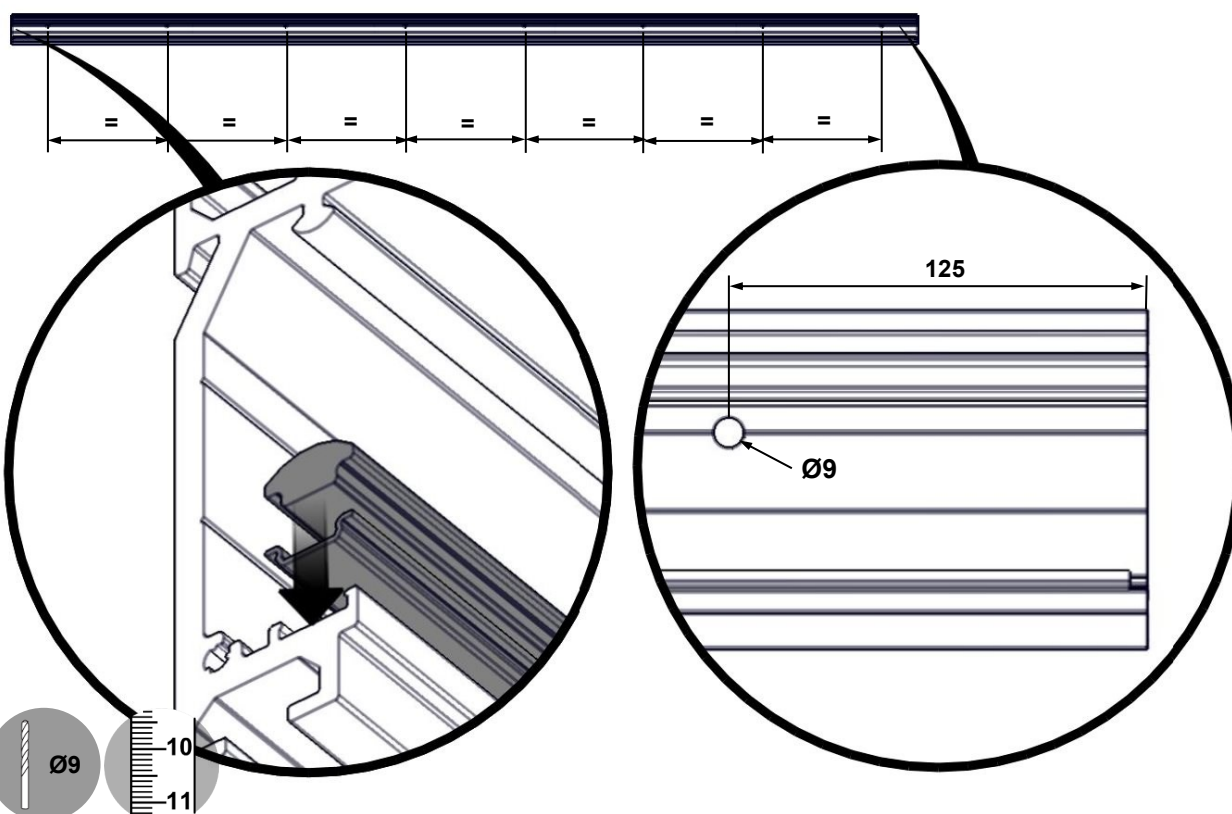

- 2.2C** Assemble extensions on the slow leaf trolleys and slide them over the track rail so that the long trolley is placed on the side opposite to the opening direction.

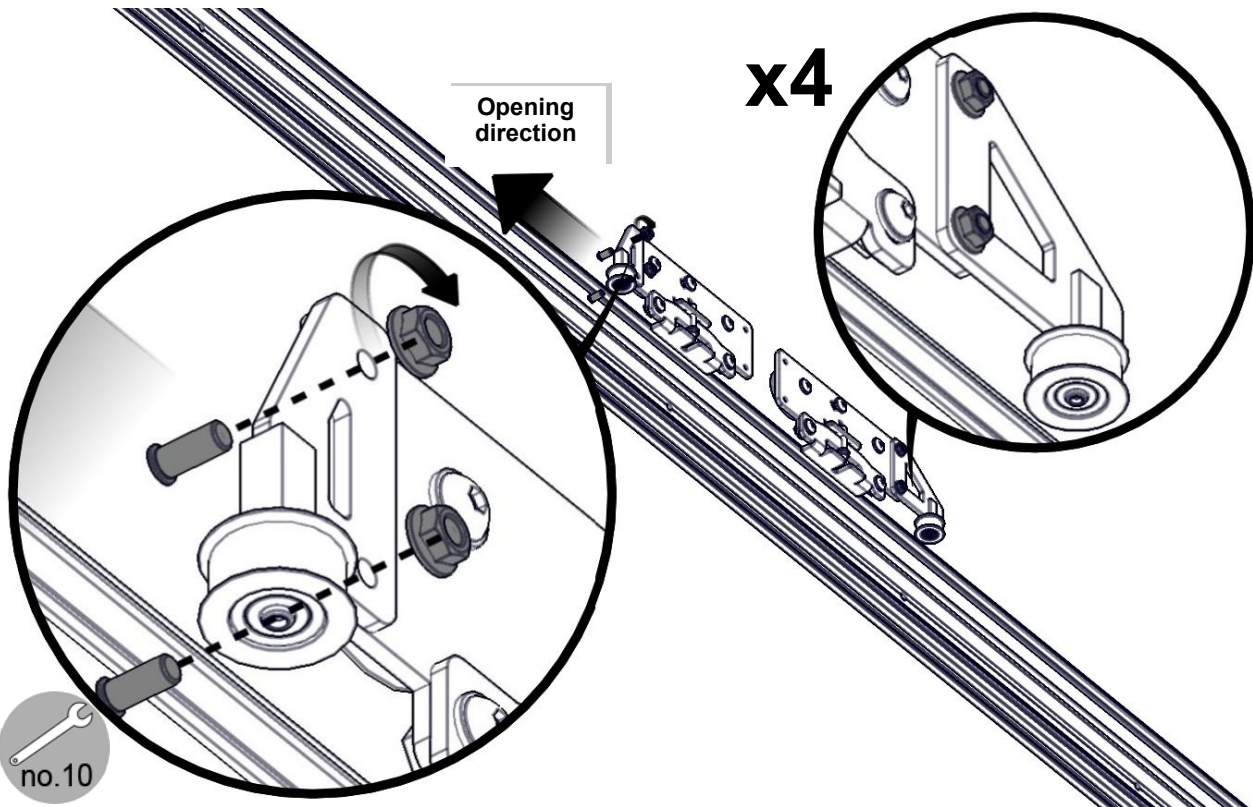

- 2.2D** Cut the threaded rod to the length indicated in the table.

	SLIDING	BI-PARTING
L	L= PL/2-335	L= PL/4-335

- 2.2E** Assemble tensioner inside the trolley and join the two slow-leaf trolleys with the rod and nuts. Adjust the counter-wheel and verify that it slides smoothly.

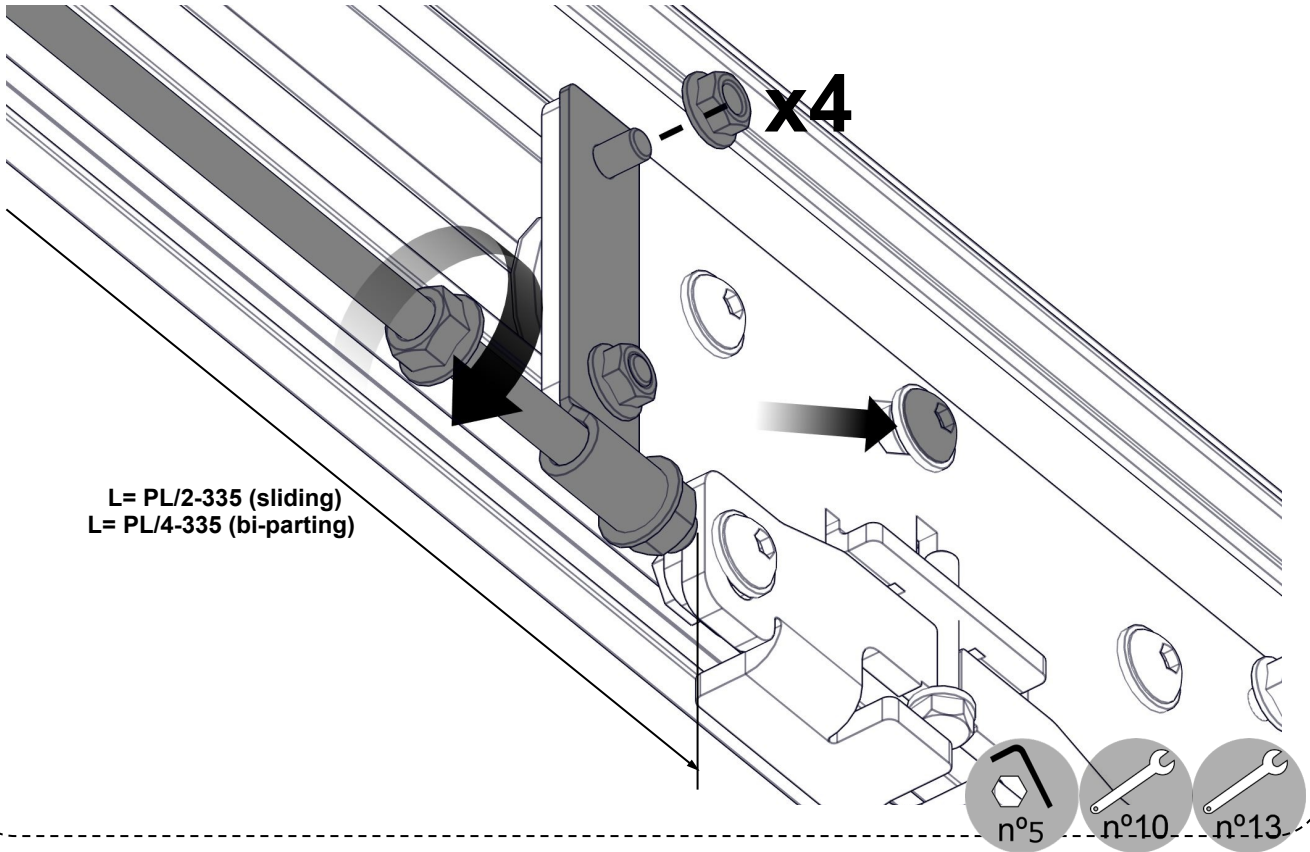

- 2.2F** Attach and screw the telescopic end stops over the telescopic stiles as per the given measurements.

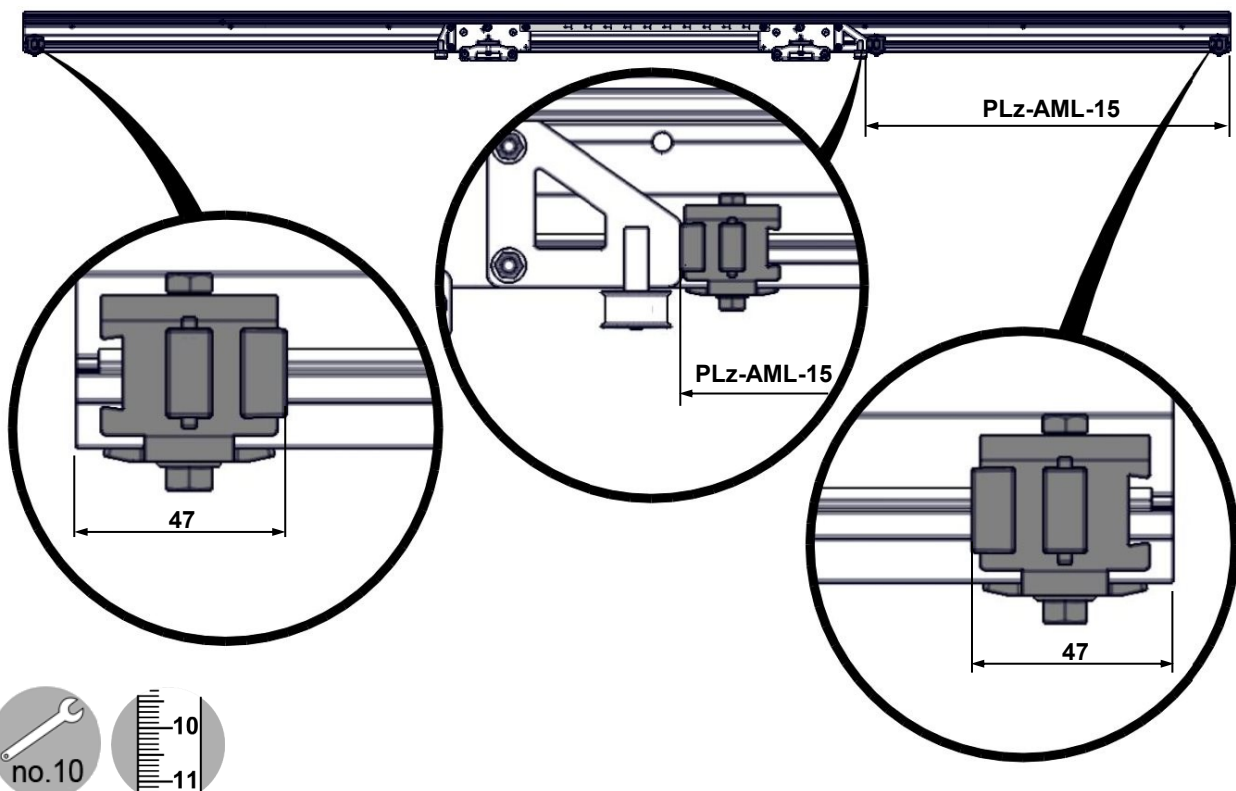

- 2.2 G** Attach the fixed anchors in the synchronization belt by performing a slight turn in the lower channel of the telescopic stile.

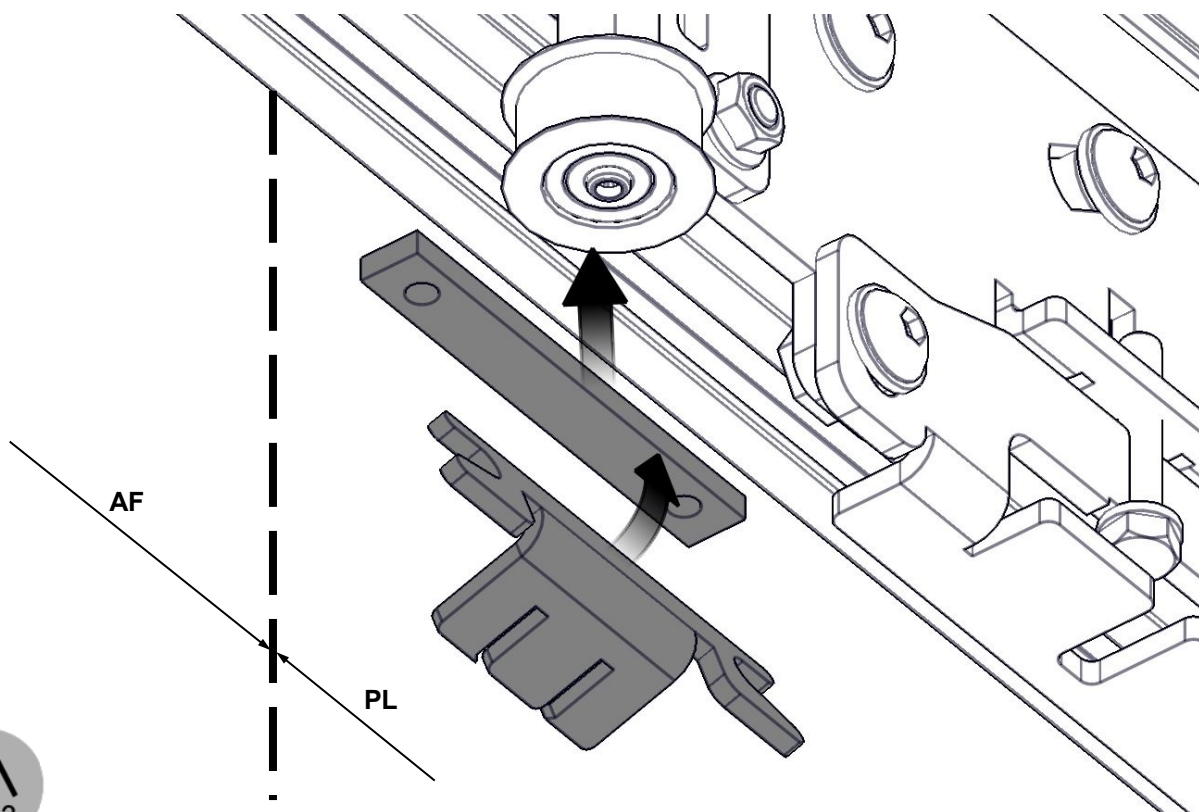

- 2.2 H** The anchorage centre must be at a 25mm distance in relation to the fixed leaf (AF) or the inside end of the clear width (PL).

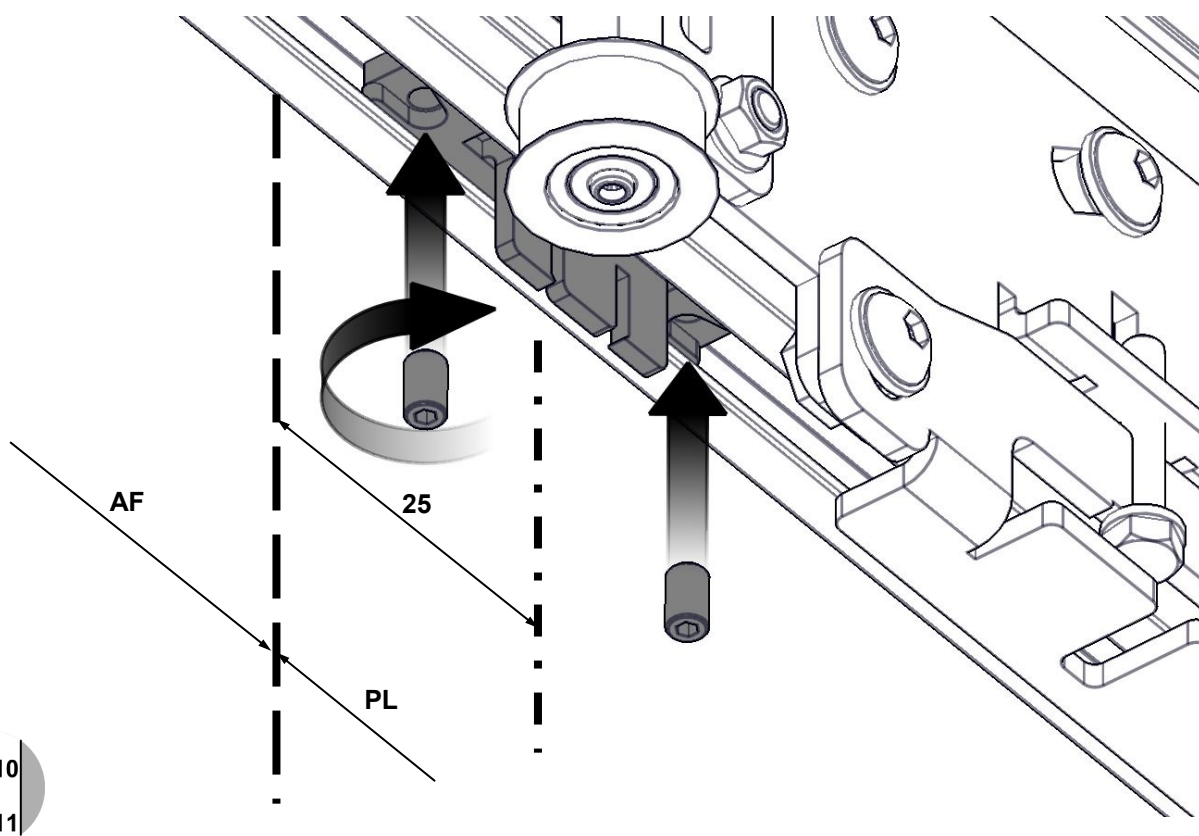

2.3 Track Set Assembly: Fast Leaf

2.3A Assemble the rest of the Visio Operator as described in the installation manual.

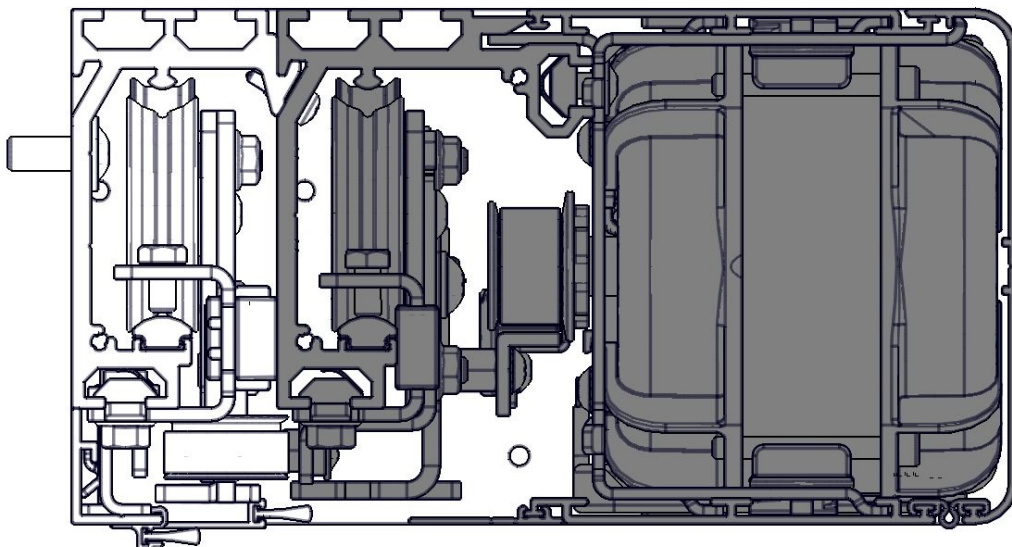

2.3B Insert the main profile over the telescopic stile using the crimp. Join the stiles drilling holes in the first one at the centre and at 400mm from the ends. Fix both stiles with screws.

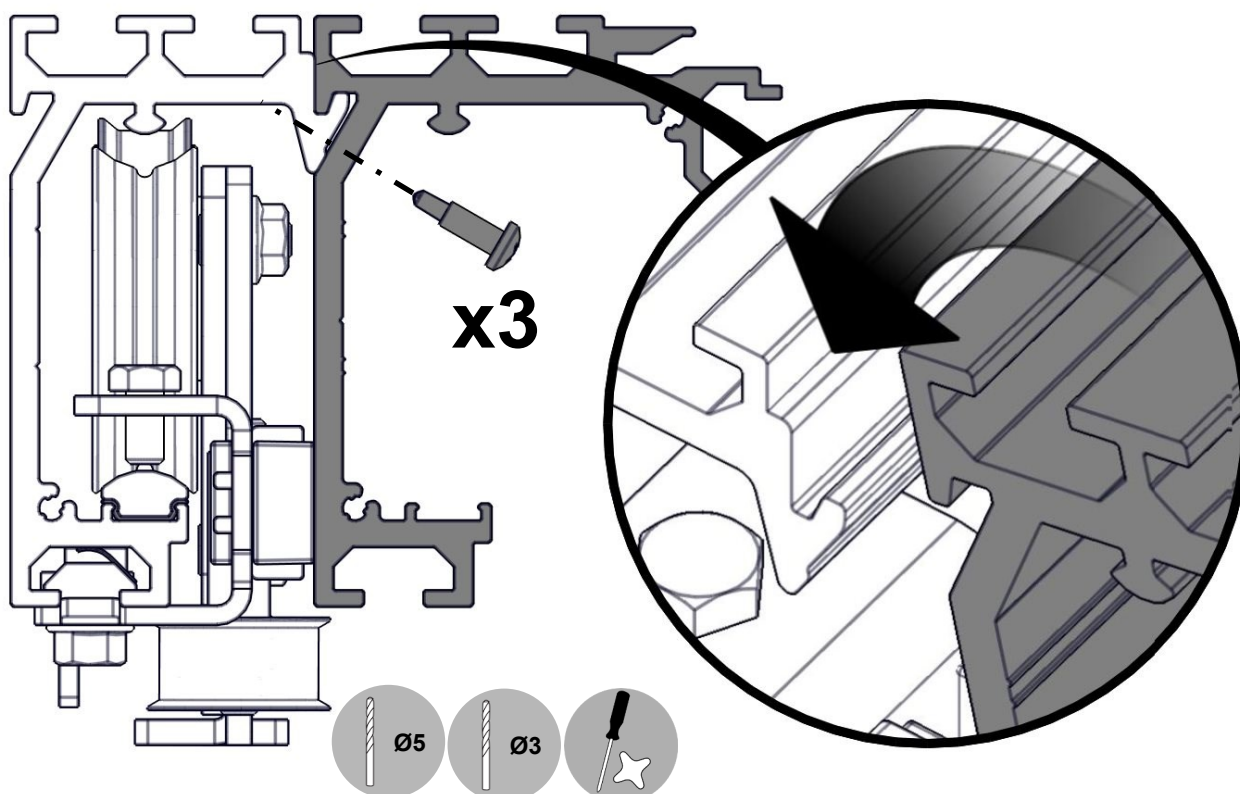

- 2.3C** Assemble the track, the trolleys and the end stops as described in the Visio installation manual, and following the measurements given in the figure below.

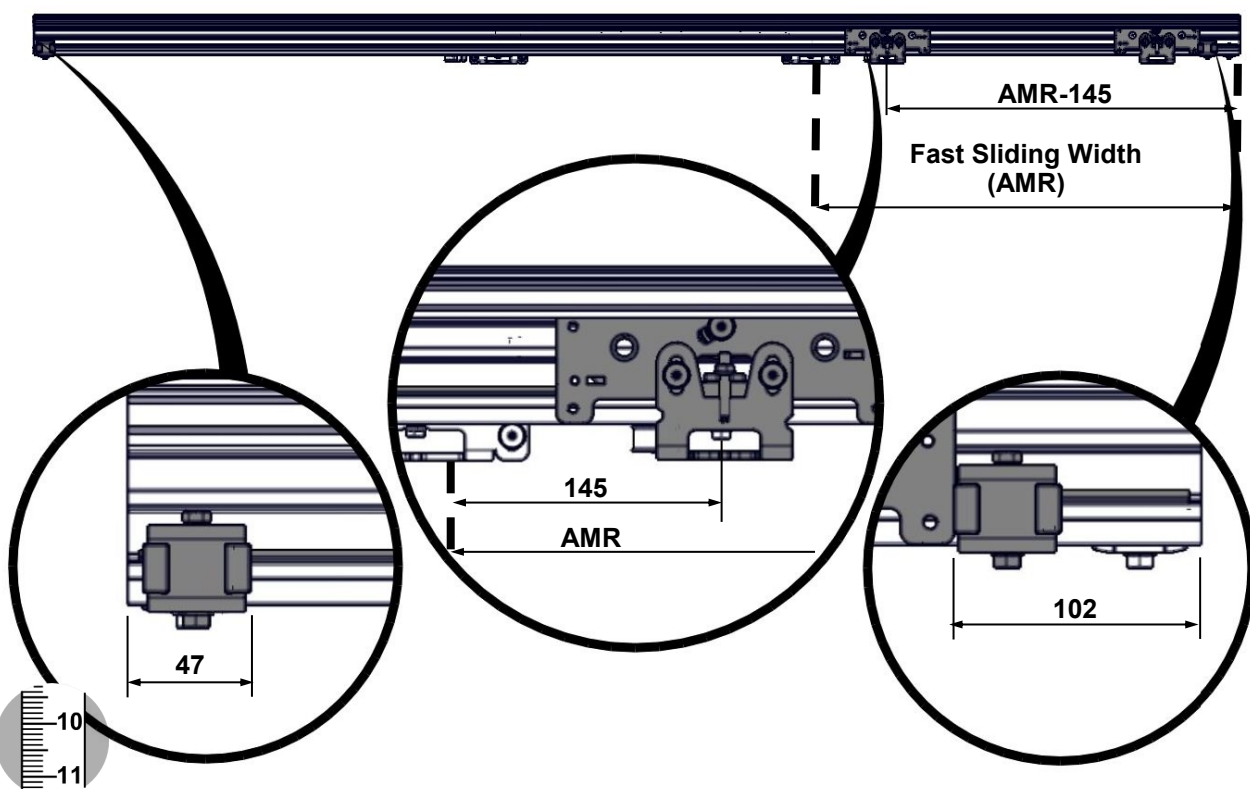

- 2.3D** In order to join the fast and the slow leaves, assemble the synchronisation arm over the fast leaf rear trolley.

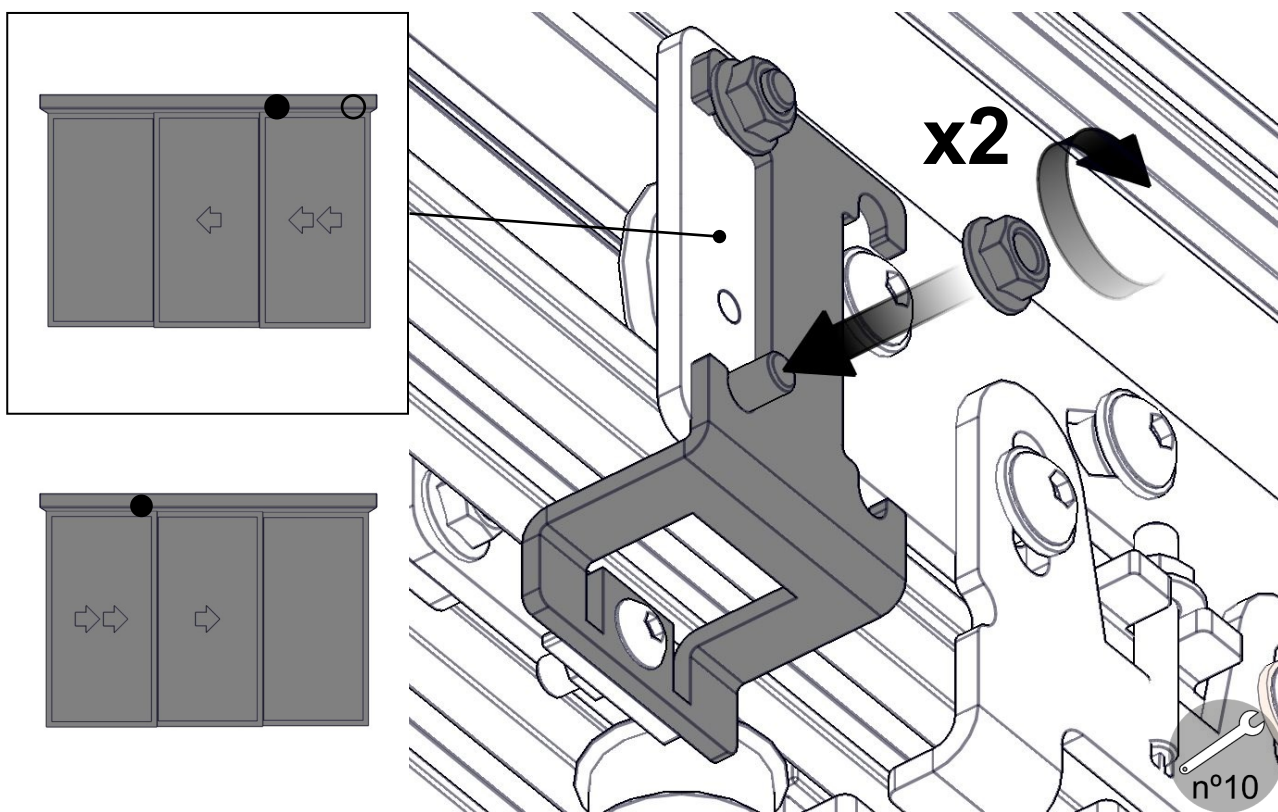



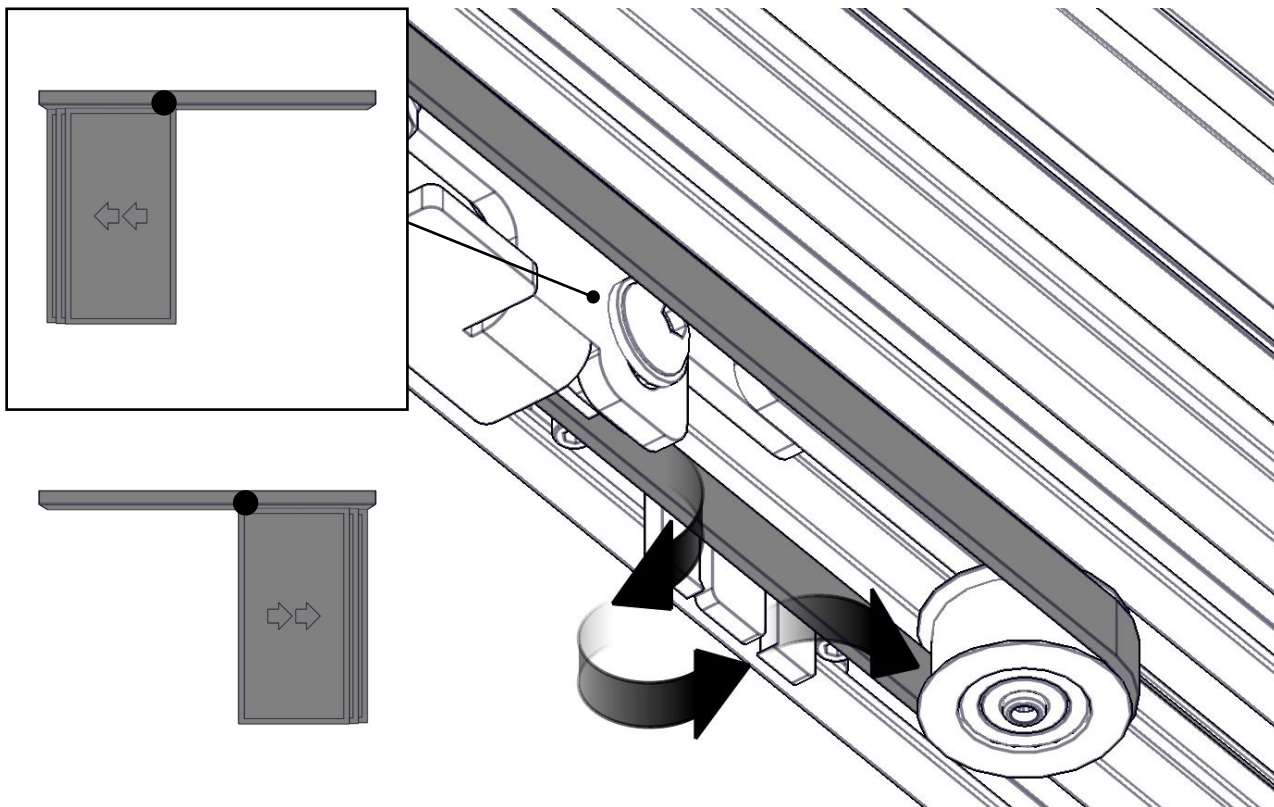

- 2.3 E** Placing the trolleys in the open leaf position, assemble the 10 mm belt with the flat surface over the pulleys (toothed surface outwards), as indicated in the figure below.

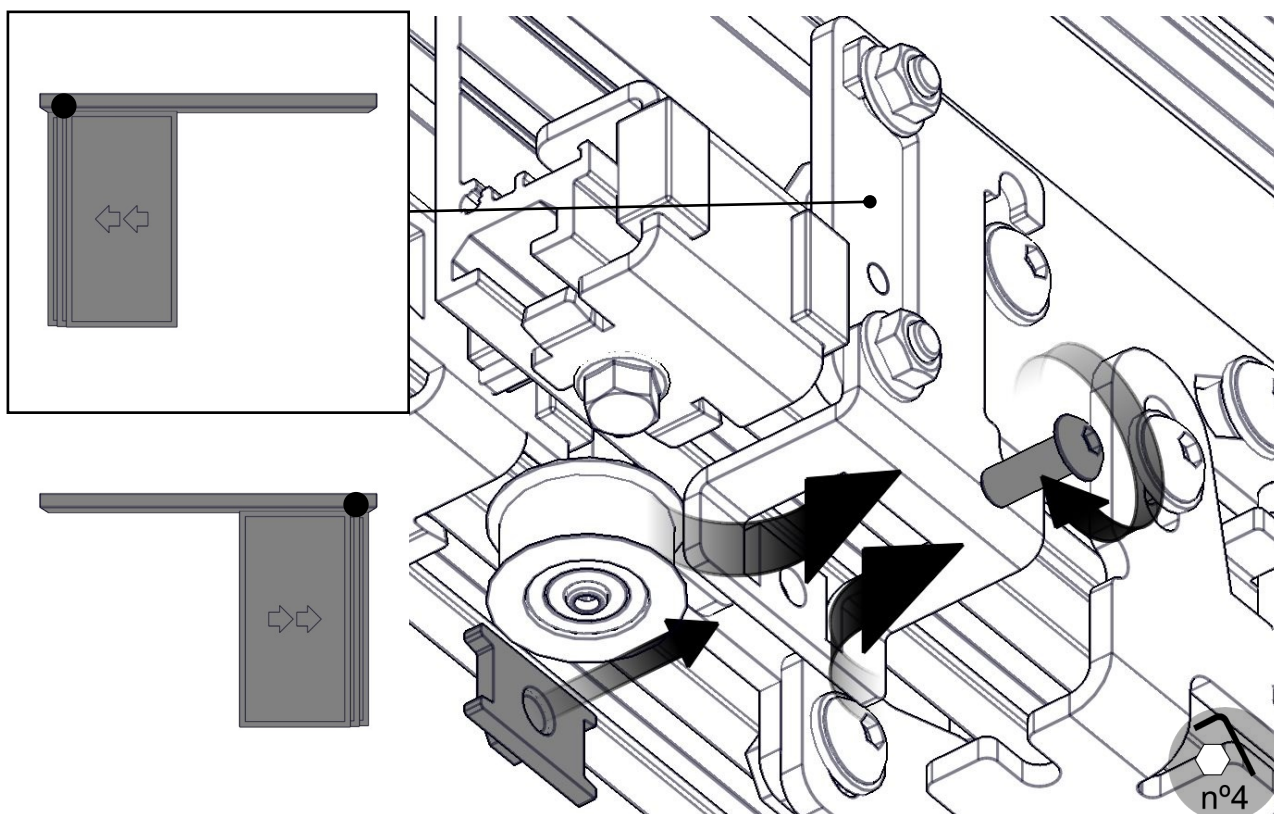

- 2.3 F** Pass the belt through the slots in the fast-leaf synchronisation arm. Tighten and close the fastening. Flange or cut the unused belt. Turn tensioner nut to tighten the belt once assembled.

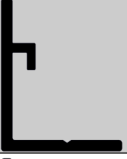
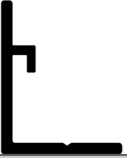
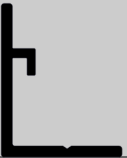
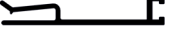

2.4 Cut Formula Table; Clear Width Stiles

STILE		SIDE		MEETING	
		With fixed leaves	Without fixed leaves	With fixed leaves	Without fixed leaves
	E20	PLz + 40	Lop - 5	PL + 80	Lop - 5
	E20 I30	(Lop - 5)-(PLz + 40)	-	(Lop - 5)-(PL + 80)	-
	I30	PL/2 - 2,5	PL/2 - 2,5	PL/2	PL/2
	E20/I30	PLz - PL/2	PLz - PL/2	PL/2	PL/2
	E20/I30	PLz - PL/2	PLz - PL/2	PL/2	PL/2
	E20/I30	PL/2	PL/2	PL/4	PL/4
	I30	PL/2	PL/2	PL/4	PL/4
	E20	PL/2	PL/2	PL/4	PL/4

2.5 Assembly of Clear Width Stiles

2.5A Continue with the assembly of the clear width stiles and the wool pile sealings.

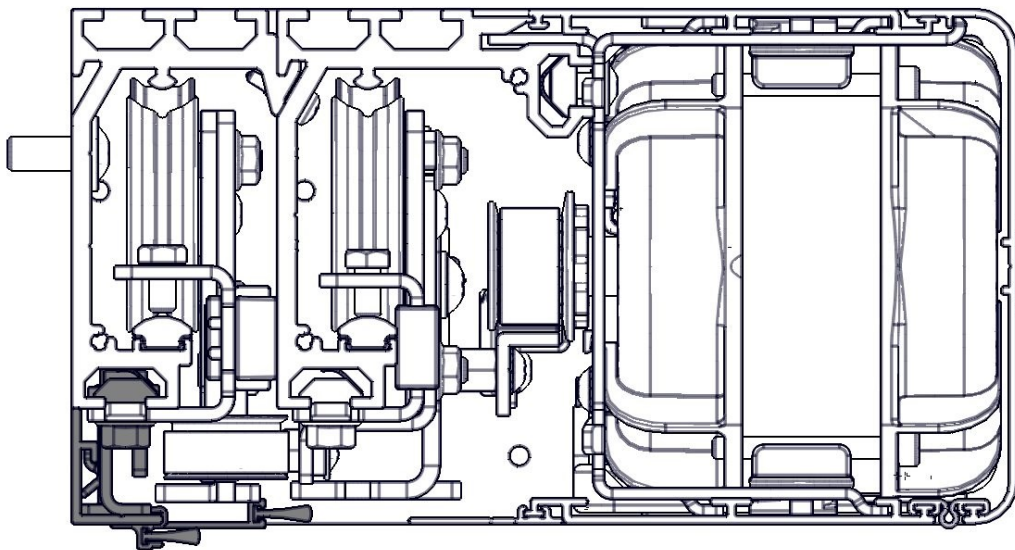

2.5B To hold the wool pile stiles and the E20 fixed leaves, cut the clear width profile as per the given measurements (the remaining cut stile is for attaching the fixed leaves). For I30 fixed leaves, use the Visio lintel stile.

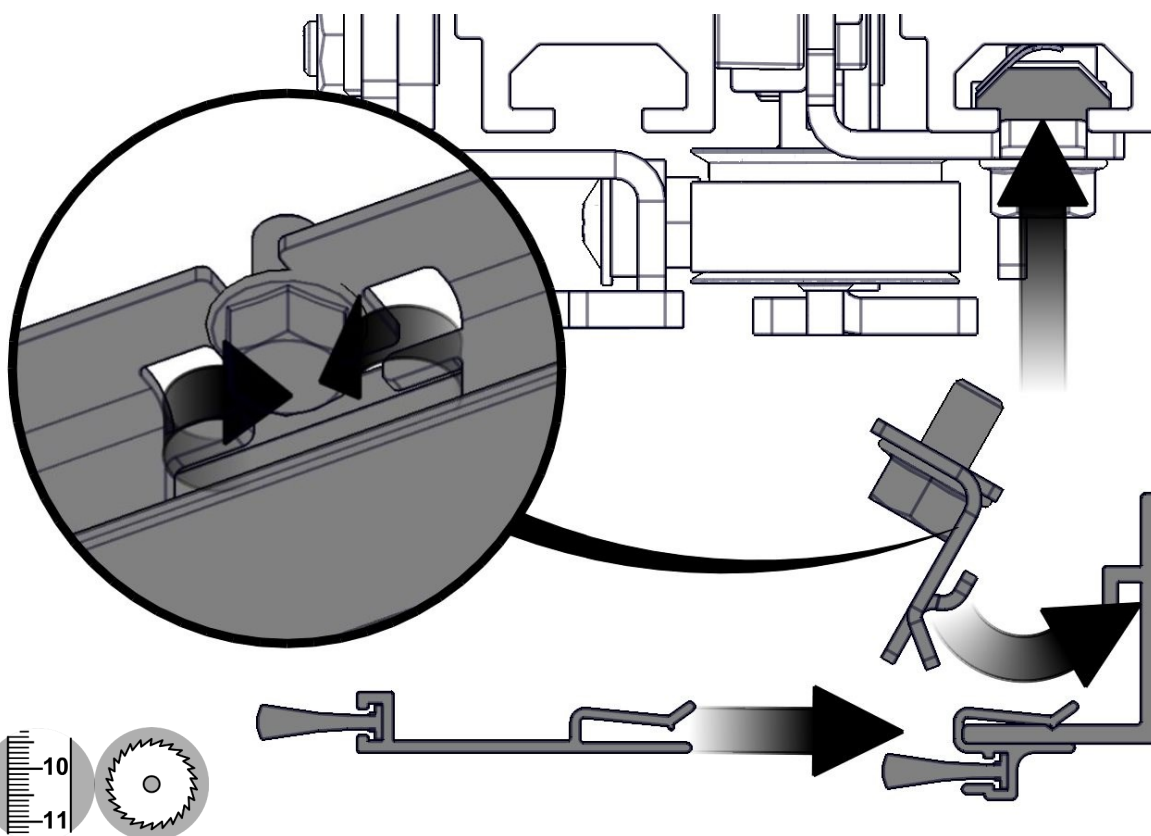

2.5C

Place the fasteners of the clear width stiles as specified in the figure below.

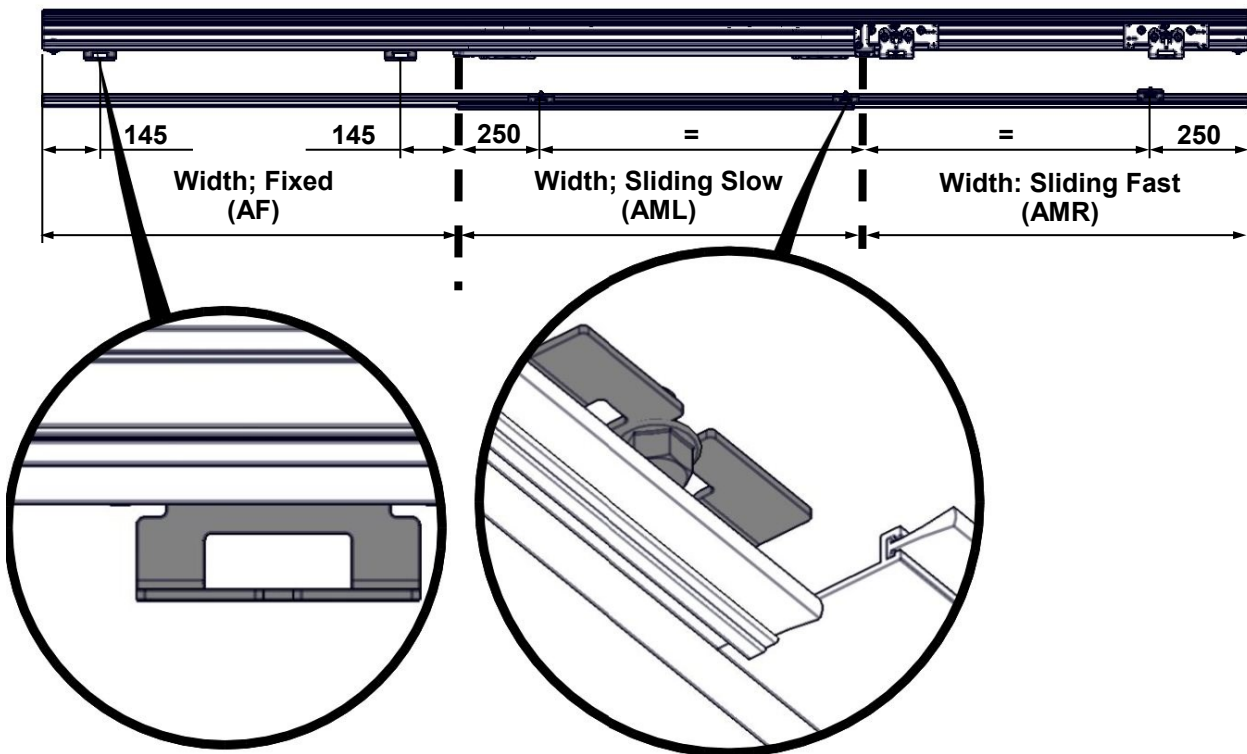

2.5D

If there are fixed leaves, drill the stile to attach the fixed leaf and join the assembly to the inside of the telescopic stile.

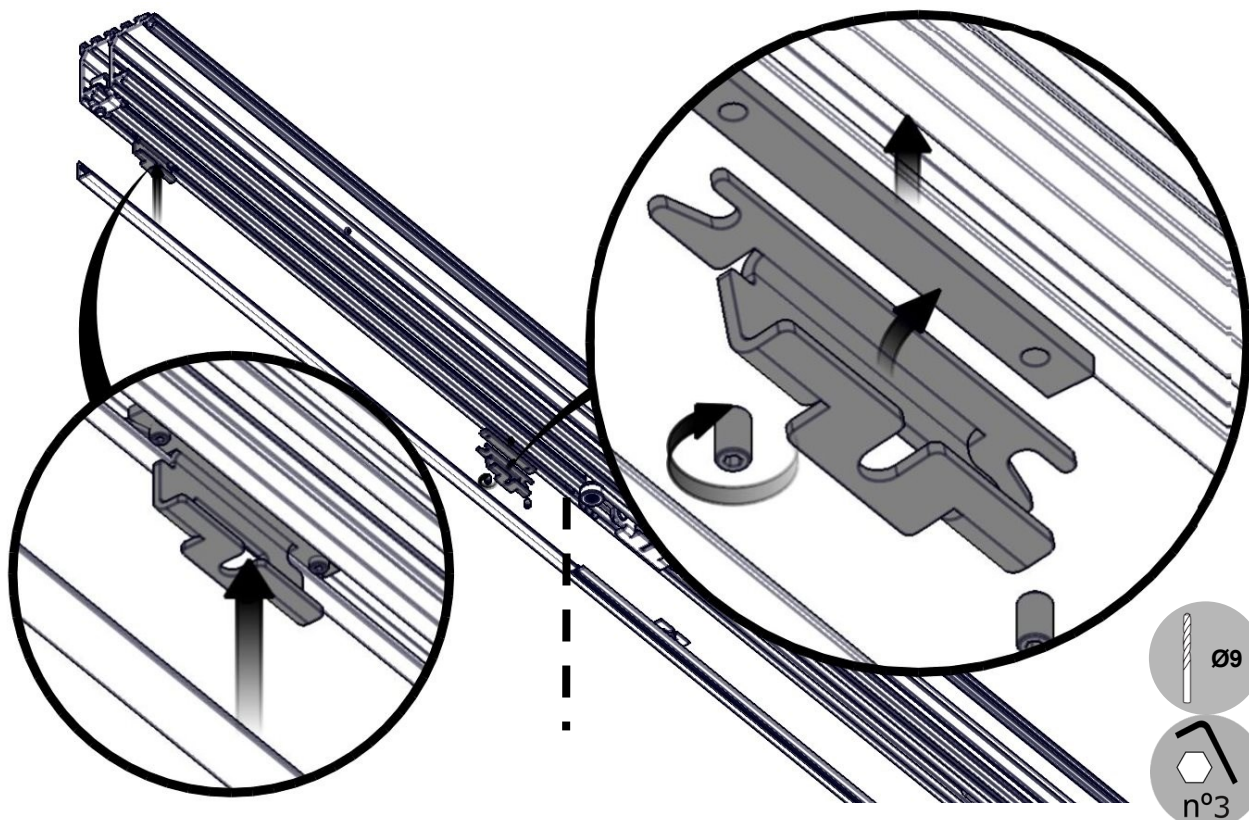

- 2.5 E** Assemble the rest of the Visio Operator as described in the installation manual. (Motorisation, chassis, ...). Check manually the opening and closing of the leaves, ensuring they are synchronised correctly.

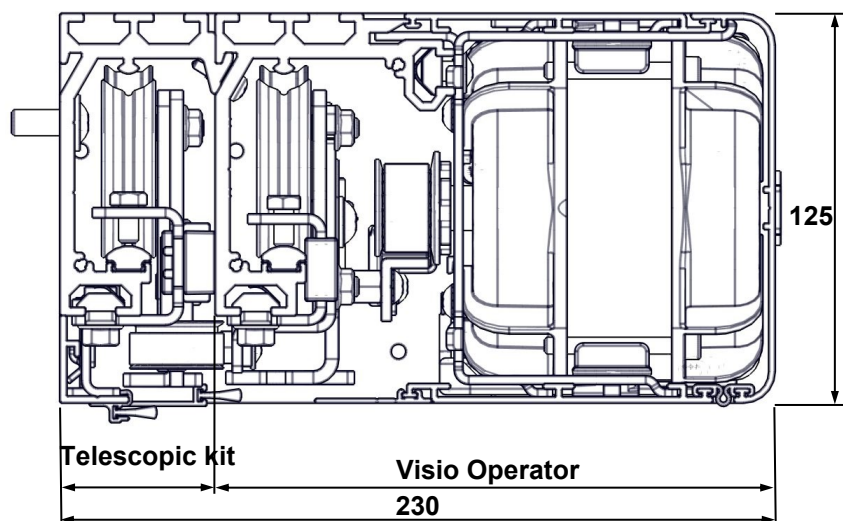

Telescopic	between motor centers	Belt length
Lateral	PL+209	2*PL-650
Central	PL-742	2*PL-1200

3 CENTRAL OPERATOR ASSEMBLY

For assembling the central telescopic operator use, for each of the operator sides, the same positioning as for a side operator, and taking the centre of the clear width as reference, for all the leaves.

Please refer to table 2 in section 2.1 C for cutting the trolley joining piece.

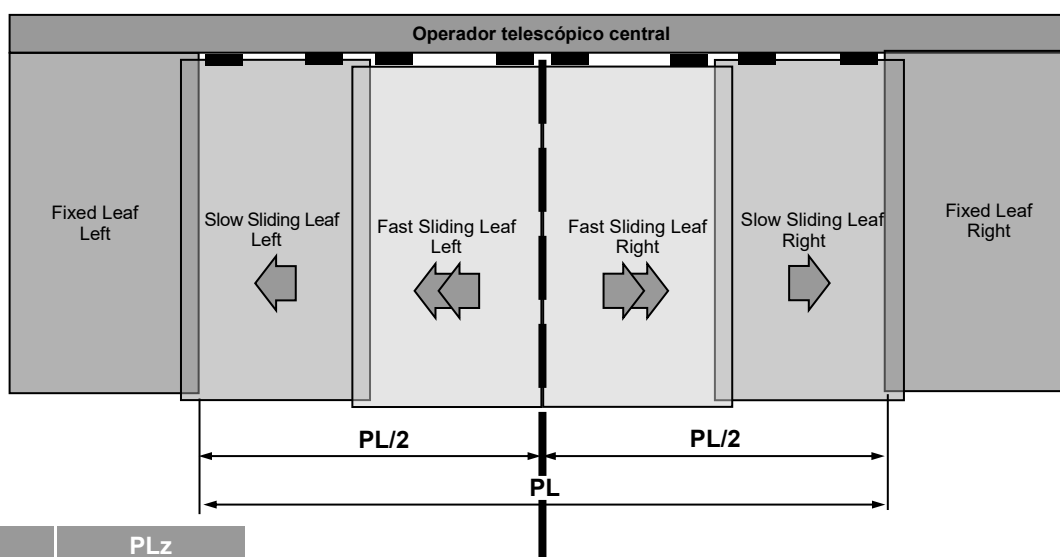

Leaves	PLz
F20	PL/2
D20	PL/2
E20	PL/2
I30	PL/2

4 APPENDIXES

4.1 CE Declaration of Conformity



CE DECLARATION OF CONFORMITY

Manufacturer: MANUSA DOOR SYSTEMS

Address: Av. Vía Augusta, 85-87, 6th Floor
08174 Sant Cugat del Vallés
Barcelona - Spain
Tel. +34 902 321 400
Fax +34 902 321 450
www.manusa.com



Product: Visio Operator. Operator for powered pedestrian doors.

Models: Visio
Visio Hermético
Visio 100

We herein declare, under our sole responsibility, that the products listed and referenced comply with the following European Directives:

2006/42/CE	Machinery Directive
305/2011/CE	Construction Products Regulation
2004/108/CE	Electromagnetic Compatibility Directive
2006/95/CE	Low Voltage Directive

It has also implemented the following harmonised standards and technical specifications:

Technical Building Code. Basic Document SUA. Operation Safety and Accessibility
Technical Building Code. Basic Document SI. Fire Safety
Technical Building Code. Basic Document HR. Noise Protection
Technical Building Code. Basic Document SE. Structural Safety
UNE-EN 16005
UNE 85121
UNE-EN 60335-1
IEC 60335-2-103
UNE-EN 61000-3-2/3-3/6-2/6-3
UNE-EN ISO 13849-1/2
UNE EN ISO 12100-1/2
UNE-EN ISO 13857
UNE-EN ISO 14121-1/2
UNE-EN 1037

The CE marking is included in the product to indicate conformity with the essential requirements of the applicable directives. This declaration of conformity means that the machine installation and start-up has been made in accordance with the assembly, operation and maintenance instructions from the manufacturer.

Josep Mª Guilera
General Manager
Sant Cugat del Vallés, December 2013

Francesca Martínez
Product Standardisation

Las características reflejadas en este documento se dan a título informativo, y no tienen carácter contractual. El fabricante se reserva el derecho a modificaciones sin previo aviso.
The characteristics indicated in this manual are purely informative and are in no way binding. The manufacturer reserves the right to make modifications without prior notice.
Les caractéristiques reflétées dans ce document sont données à titre indicatif, elles n'ont pas de caractère contractuel. Le fabricant se réserve un droit de modifications sans avis préalable.
As características exibidas neste manual se dão a título informativo, e não têm caráter contratual. O fabricante se reserva o direito a alterações sem aviso prévio.

manusa 

OFICINAS CENTRALES
Av. Vía Augusta, 85-87, 6^a
08174 Sant Cugat del Vallés
Barcelona - España
Tel. +34 902 321 400
Fax +34 902 321 450